

Description

This is a battery-operated, standalone system with wireless connectivity using Wi-Fi® Low Energy communication. This solution detects the leakage of flammable gases using ZMOD4410 gas sensor. It can be a very useful system for industrial and household applications. In this system, the information about the LPG/PNG gas leakage can be detected, alarmed, and communicated to users through a single microcontroller (MCU) with built-in Wi-Fi communication. The Wi-Fi communicates with the nearest router and sends all the updates.

Kit Contents

- AS043 Flammable Gas Leakage Detector Board

Features

- Stand alone, wall mounted system, compact size, and low component count.
- Wireless connection for IoT system with DA16200 Wi-Fi module
- Improved algorithm for very long lifetime, ultra-low power consumption using ZMOD4410 and HS3003 for Leakage detection.
- Extended interfaces using PMOD for BLE or standalone MCU operation.
- LED indication is given for Wi-Fi connectivity indication, low battery indication and leakage detection.
- Buzzer indication for safety/security risk from gas leak
- Standardized Type 3A Pmod™ connector supports Expanded UART interface.

Evaluation Board



Figure 1. AS043 Flammable Gas Leakage Detector Board

Contents

Description.....	1
Kit Contents.....	1
Evaluation Board.....	1
Features.....	1
Contents.....	2
AS043 Overview.....	3
Hardware Overview.....	4
Network configuration and Firmware Flashing Steps.....	8
Device Setup.....	13
AS043 Application Schematic.....	15
Bill of Materials (BOM).....	16
Board Layout.....	17

AS043 Overview

AS043 is a battery-operated system in which ISL9122A is used for Buck-Boost DC-DC converter supplying power to all the peripheral devices. DA16200MOD has inbuilt wide voltage operation. It will detect battery voltage and alarm the low voltage signal. DA16200MOD is an ARM Cortex M4 MCU with inbuilt Wi-Fi® Low Energy communication chip. It captures the TVOC, eCO₂, and EtOH parameters from ZMOD4410 gas sensor. The algorithm is defined to detect the leakage of flammable gases using these parameters. HS3003 temperature and humidity sensor is used for low power applications. The AS043 incorporates multiple building blocks, along with software resources to provide a complete fire safety solution, capable of standalone operation and requiring no external inputs for gas sensing leakage management and control.

The block diagram below highlights the main parts of the system:

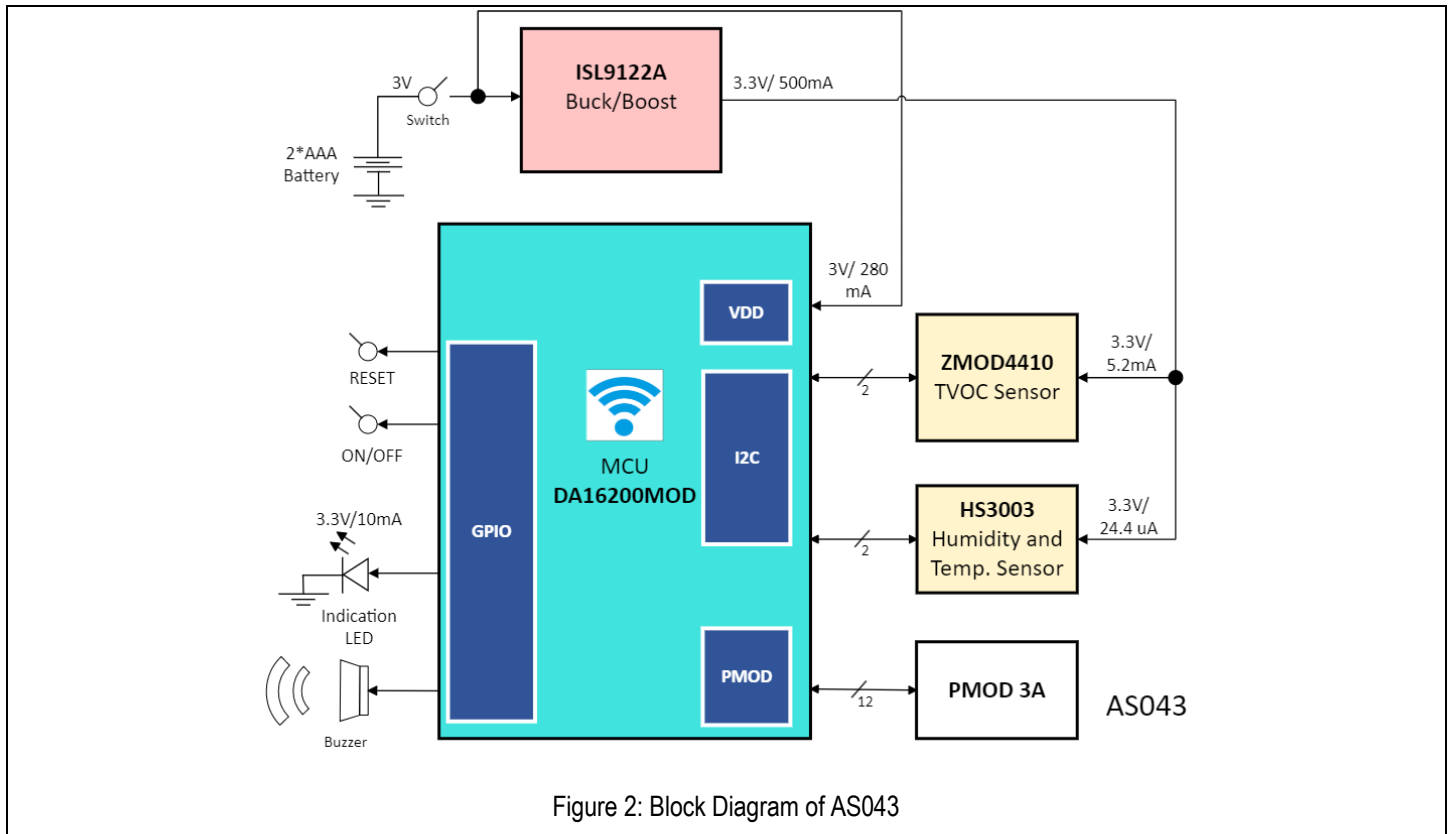

Figure 2: Block Diagram of AS043

The building blocks of the AS043 and their functionality are listed below:

1. [DA16200MOD](#): Ultra-Low Power Wi-Fi Modules for Battery Powered IoT Devices. They deliver the same long battery life and low power consumption but in a convenient form factor. The fully integrated module consists of the DA16200 SoC, 4MB flash memory, RF components including crystal oscillator, RF lumped filter, and either a chip antenna or a connector for an external antenna.
2. [ZMOD4410](#): Firmware Configurable Indoor Air Quality (IAQ) Sensor with Embedded Artificial Intelligence (AI). The ZMOD4410 gas sensor module is an easily integrated firmware configurable architecture enabling multiple sensing solutions with a common hardware platform.
3. [HS3003](#): The HS3003 is a highly accurate, fully calibrated relative humidity and temperature sensor.
4. [ISL9122A](#): Ultra-Low IQ Buck-Boost Regulator with Bypass. The ISL9122A is a highly integrated non-inverting buck-boost switching regulator that accepts input voltages both above and below the regulated output voltage.

Hardware Overview

The following block diagrams have specific applications explained below.

1. DC-DC Converter: ISL9122A DC/DC buck-boost converter having wide operating range from 2.8V to 4.5V. It provides the 3.3V supply to the HS3003 and ZMOD4410. The DC/DC converter can be controlled through I2C. C1 and C2 are input filter and bypass capacitors which will avoid ground debouncing and provide stable voltage. Similarly, C3 and C4 are for output voltage filtering and stabilization. R1 is used as enable resistor connected with VSOURCE, as ISL9122A is active high. Since there is no I2C communication with ISL9122A, SCL and SDA pins are connected to ground.

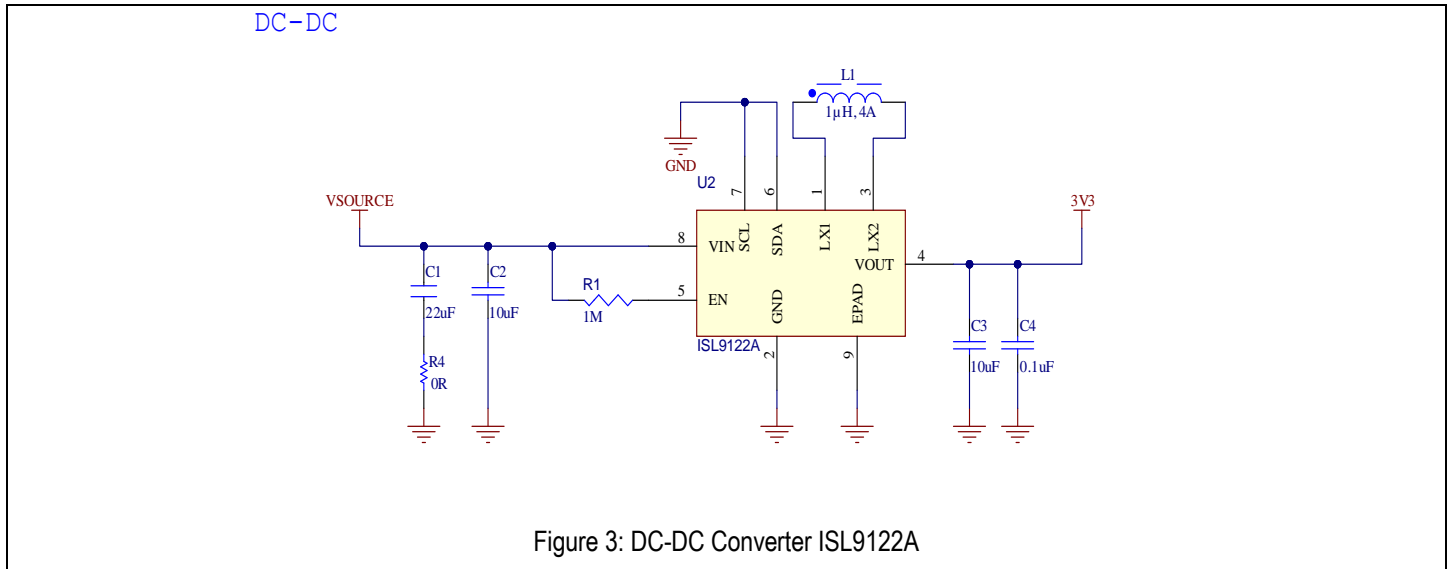

2. PMOD: This provides a UART interface with optional hardware flow control plus additional control signals. The hardware flow control signals are optional, and some PMODs do not use them. In this case pins 1 & 4 are not used or are GPIO. Pins 7-10 can be any signal, but if one or more interrupts are needed, they will be on pin 7 and if a reset is needed it will be on pin 8. The RTS signal is an output indicating that the device (host or peripheral) is ready to receive data. The device asserts this signal low when it is ready to receive data. The CTS signal is an input to the device (host or peripheral). The device will only transmit data when the CTS input is asserted low. A peripheral module that uses hardware flow control will connect the host's RTS signal to its internal CTS input and the host's CTS signal to its internal RTS output.

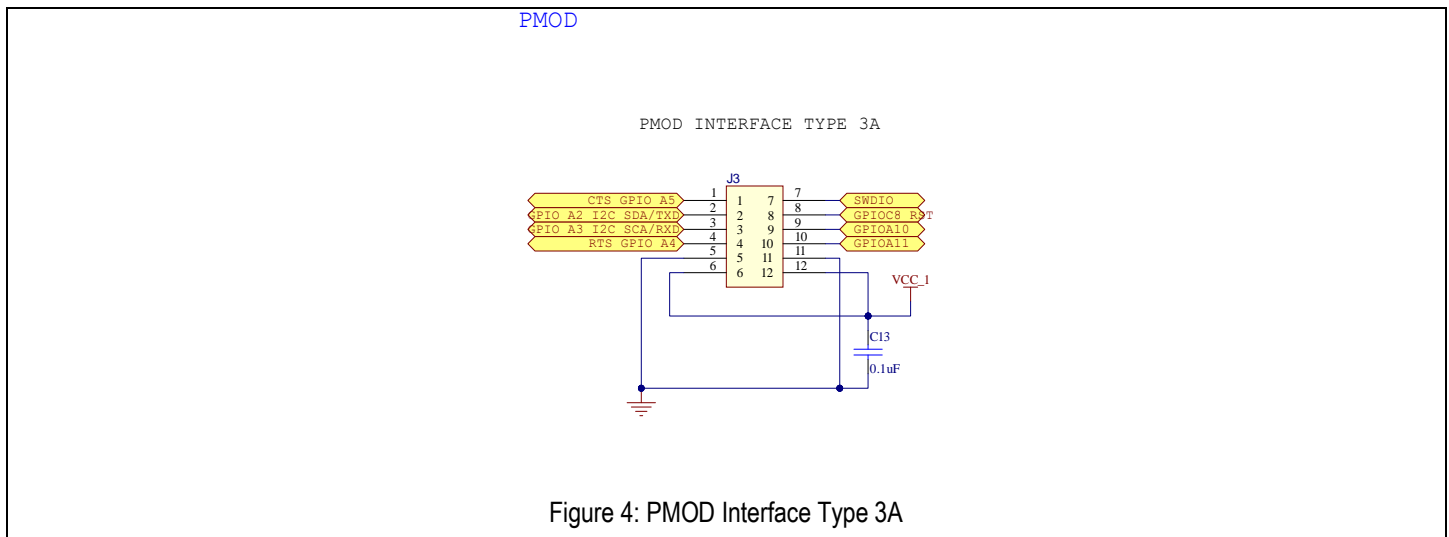

3. Battery, LED, and Buttons: LEDs are used for indication. 2*AAA batteries are used for power.

Description of LEDs:

LED Color	Reference Designator	Function
Green	DS1	Power up
Yellow	DS2	Leakage Detection
Blue	DS3	Wi-Fi indication

Description of Switches:

Switch Name	Reference Designator	Function
Reset	S1	Factory Reset. Resets the MCU
	S2	Test Button
Power	SW1	Powers up the board. To switch between source and battery voltage

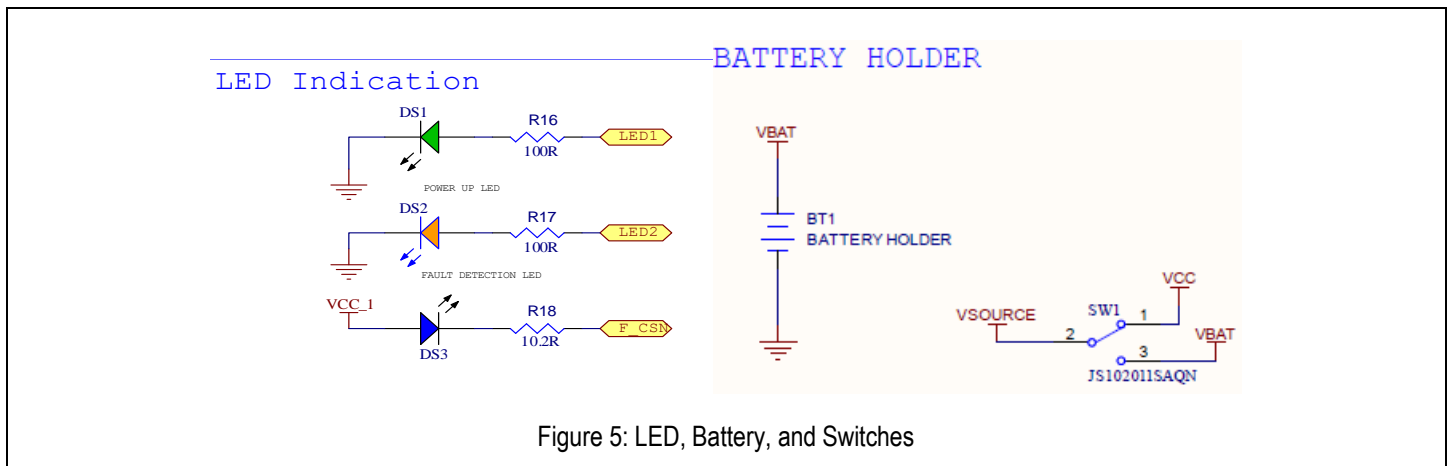

Figure 5: LED, Battery, and Switches

4. Buzzer: When the gas leakage is detected, DA16200MOD will provide signal for buzzer to indicate alert/alarm. Q1 transistor is used for allowing higher current to pass through buzzer PZ1. D1 is a freewheeling diode used to protect the transistor and MCU from reverse current. R11 (0 ohm) is a power protection resistor.

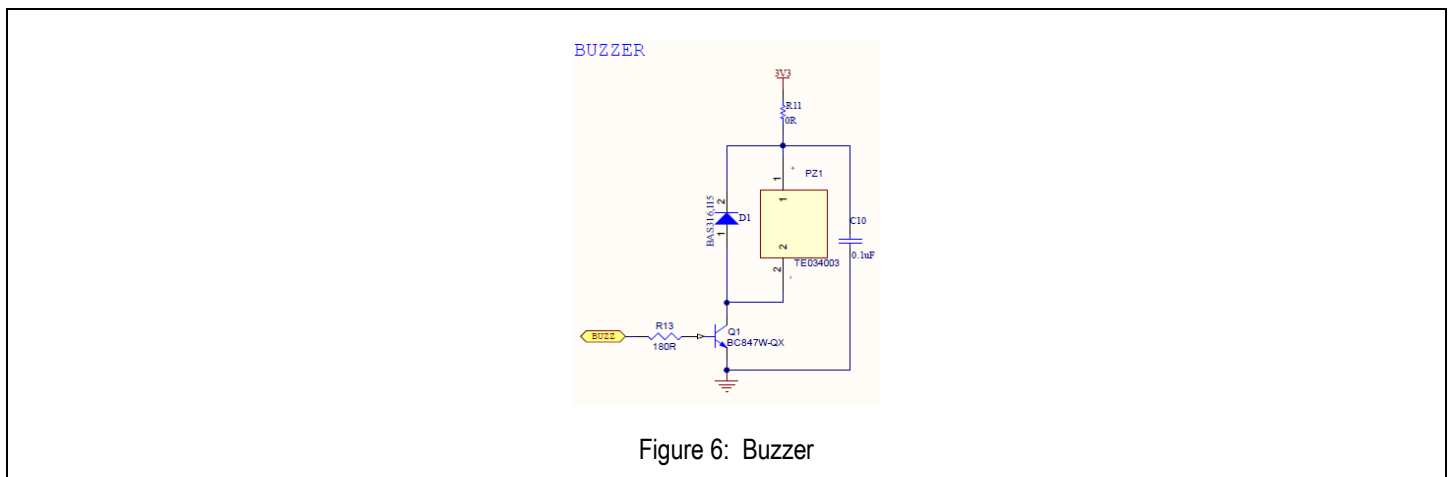

Figure 6: Buzzer

5. DA16200MOD:

The DA16200MOD is a fully integrated Wi-Fi® module with ultra-low power consumption, best RF performance and easy development environment. Such low power operation can extend the battery life as long as a year or more depending on the application. The Cortex M4 inbuilt MCU gets powered by 3.3 V from the Buck-Boost Converter ISL9122A or even directly. The MCU runs the ZMOD4410 algorithm to detect the processed data over I2C. The temperature and humidity data from HS3003 sensors also read over I2C. DA16200MOD can work into Station or Soft AP mode to transmit data over Wi-Fi. It goes into sleep mode to save battery life when it is not in use.

6. ZMOD4410:

The ZMOD4410 Gas Sensor Module is designed for detecting total volatile organic compounds (TVOC) and monitoring indoor air quality (IAQ). The MCU gets powered by 3.3 V from the Buck-Boost Converter ISL9122A. The signal conditioner controls the sensor temperature and measures the MOx conductivity, which is a function of the gas concentration. The measurement results can be read via an I2C interface with the DA16200MOD microcontroller, which processes the data to determine the TVOC concentration, IAQ rating and estimated carbon dioxide (eCO2) level. This flexibility makes the sensors in the ZMOD4410 platform capable of providing a variety of measurement options by varying the method of operation or changing the firmware used to interpret the resistance measurements. Downloadable firmware libraries and source code provided by IDT enables detection of TVOC and odors and supports smart devices measuring IAQ that require low-power operation.

7. HS3003 Temperature and Humidity Sensor:

The HS3003 is a highly accurate, fully calibrated relative humidity and temperature sensor. The high accuracy, fast measurement response time, and long-term stability, along with the small package size, makes the HS3003 ideal for a wide number of applications from portable to harsh environments. It is powered by 3.3V DC-DC converter ISL9122A. An integrated calibration and temperature compensation logic provides fully corrected RH and T values via a standard I²C output. The measured data is internally corrected and compensated for accurate operation over a wide range of temperature and humidity levels—user calibration is not required.

Wi-Fi Module and Sensors:

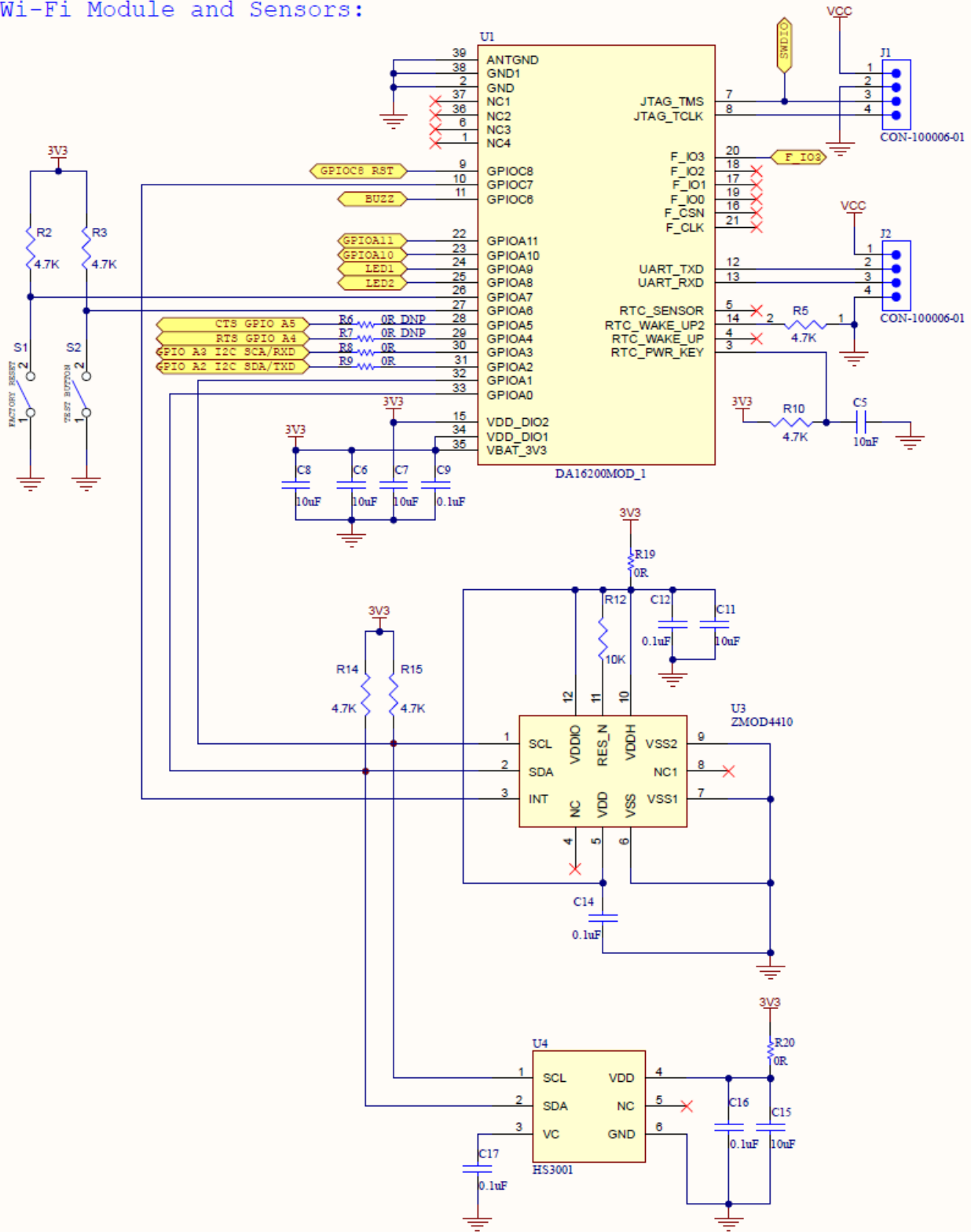

Figure 7: Wi-Fi Module & Sensor Section

Network configuration and Firmware Flashing Steps

Connect AS043 sensor with PC using TTL to USB Adapter and use Tera-term terminal software to flash firmware image to DA16200 module.

1. COM port Connection settings.

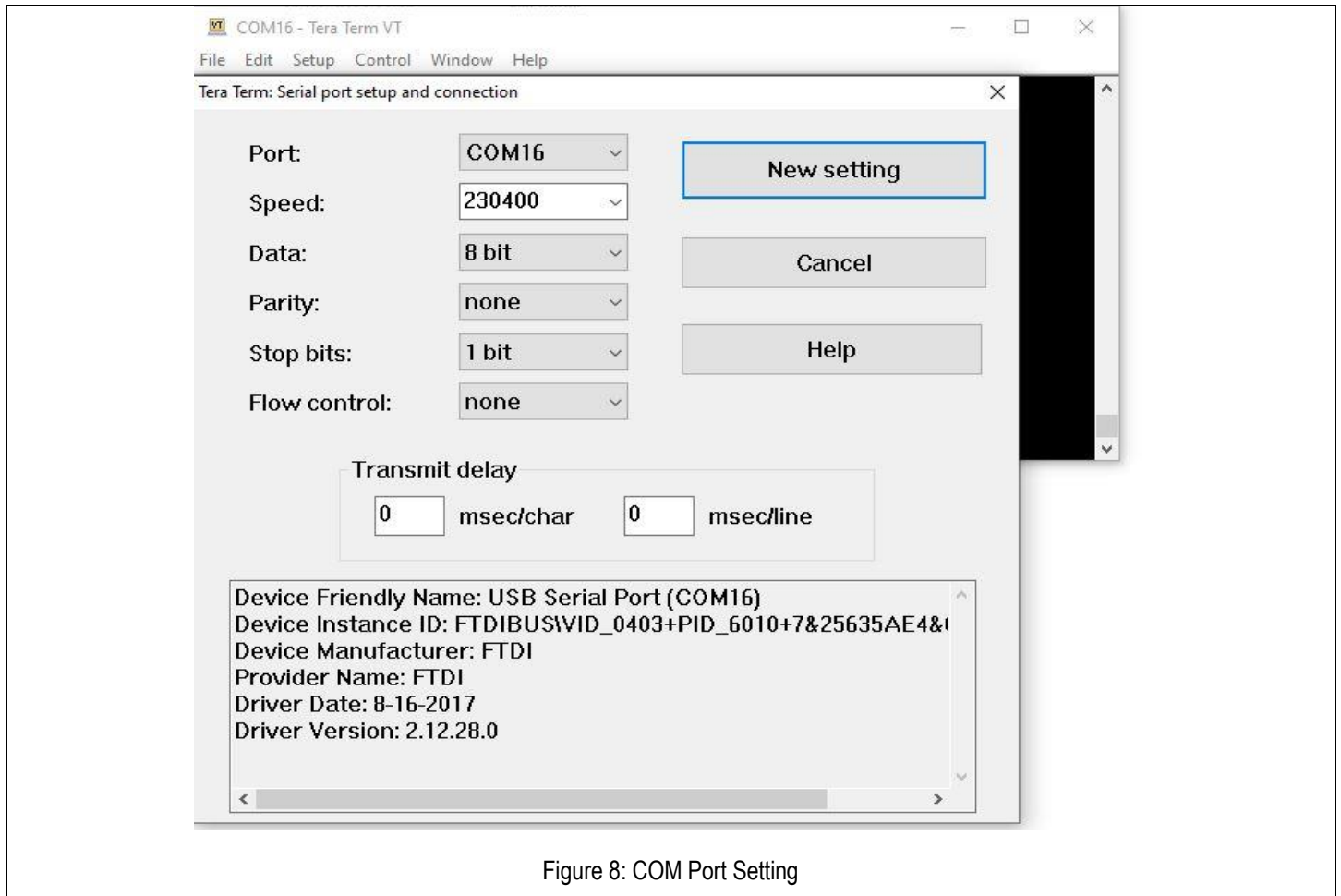

Figure 8: COM Port Setting

2. From menu select setup.

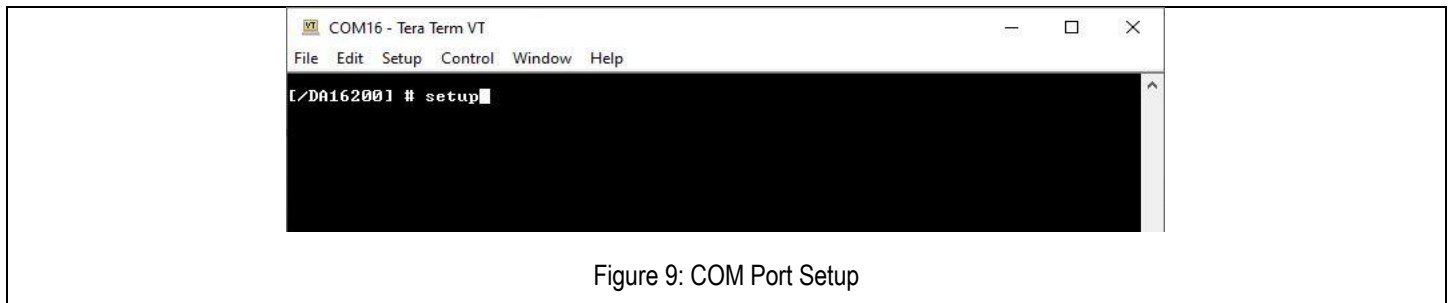

Figure 9: COM Port Setup

7. Set static IP for AS043. – ex: 192.168.1.x.
8. Set SUBNET default.
9. Set Gateway as per your router IP.
10. DNS default.
11. Confirm configuration.
12. Disable SNTP.
13. Disable DPM.

```

IP Connection Type ? [Automatic IP/Static IP/Quit] : s
IP Connection Type: Static IP
IP ADDRESS ? [Quit] <Default 172.16.0.100> : 192.168.1.2
SUBNET ? [Quit] <Default 255.255.255.0> :
GATEWAY ? [Quit] <Default 172.16.0.1> : 192.168.1.1
DNS ? [Quit] <Default 8.8.8.8> :
=====
[WLAN0]
IP ADDRESS: 192.168.1.2
SUBNET : 255.255.255.0
GATEWAY : 192.168.1.1
DNS : 8.8.8.8
=====
IP CONFIGURATION CONFIRM ? [Yes/No/Quit] : y
SNTP Client enable ? [Yes/No/Quit] : n
Dialog DPM <Dynamic Power Management> ? [Yes/No/Quit] : n
    
```

Figure 11: IP connection Setup

Flashing AS043 firmware image: Connect AS043 sensor with PC using TTL to USB Adapter and use Tera-term terminal software to flash firmware image to DA16200 module.

4. COM port Connection settings.

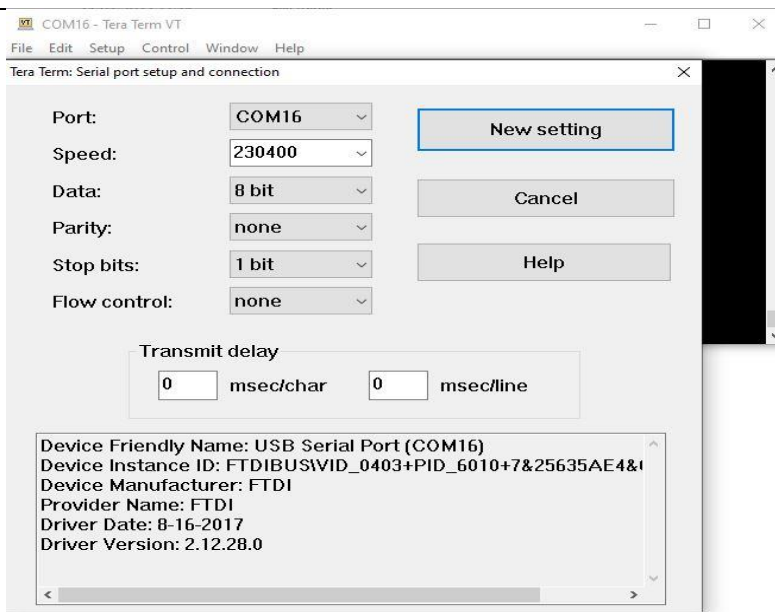

Figure 12: COM Port connection Setting

5. Select Tera-term macro to send image.

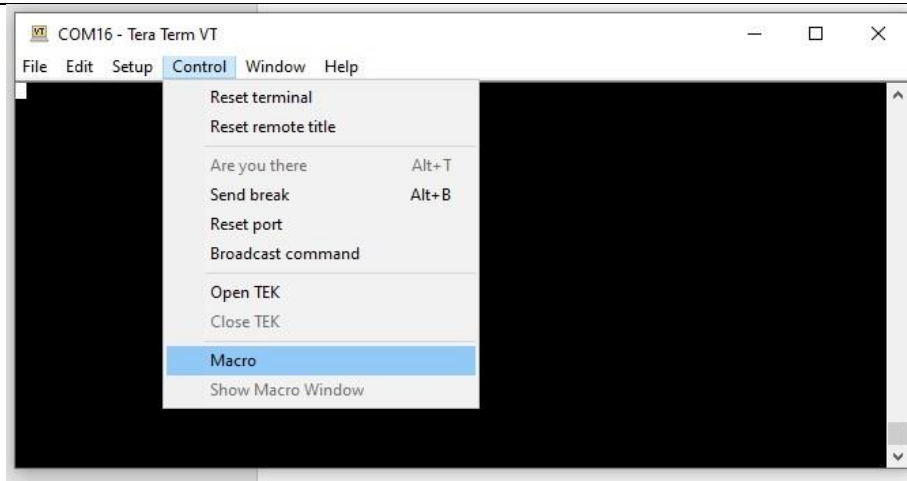

Figure 13: Tera Term/Serial Macro Setting

6. Select AS043 firmware Image to flash.

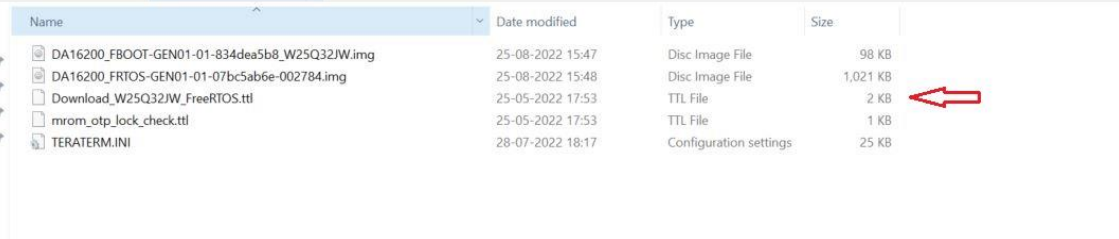

Figure 14: DA16200 Firmware Flashing

7. Image transfer will start soon after selecting .ttl macro file.

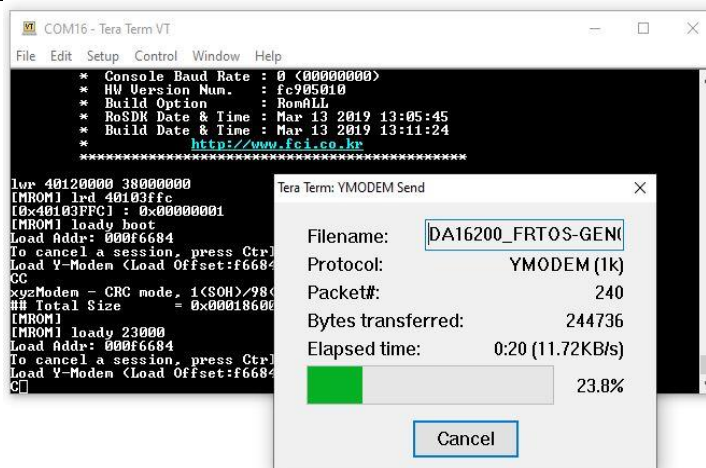

Figure 15: Firmware Image Flashing

8. After image transfer, device will reboot and from terminal AS043 measurement data can be viewed.

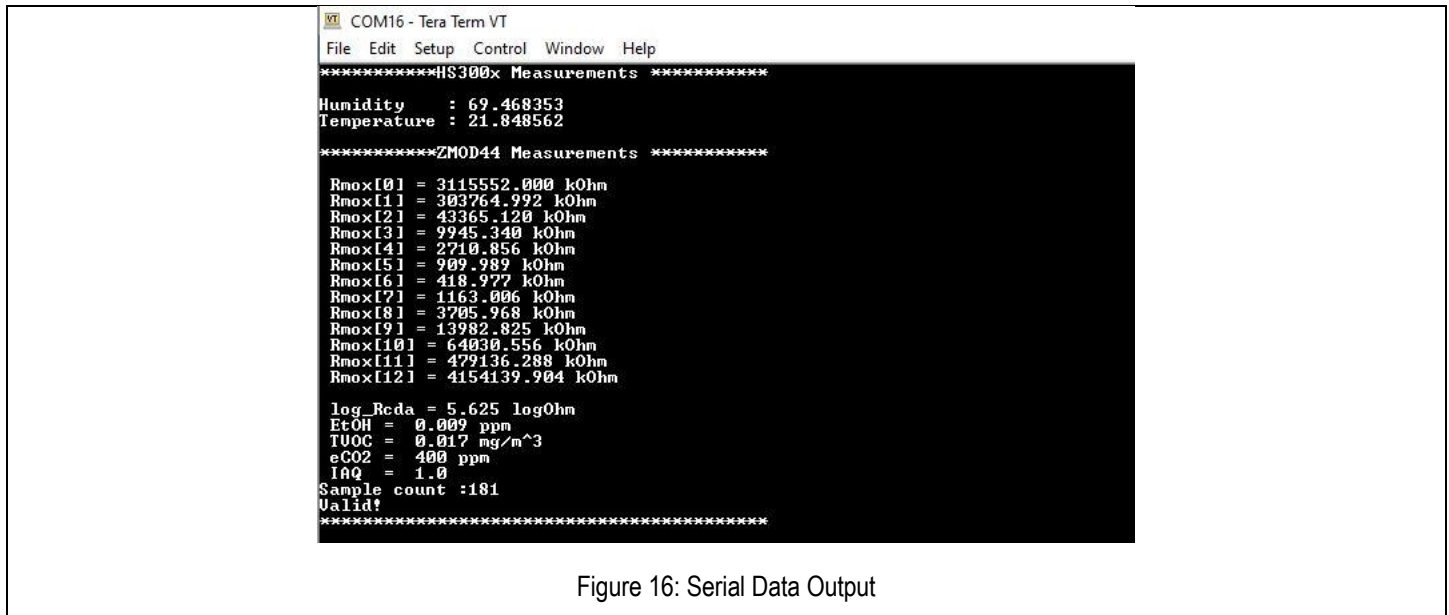

Figure 16: Serial Data Output

9. Open browser and enter sensor IP address to view sensor data on local network.

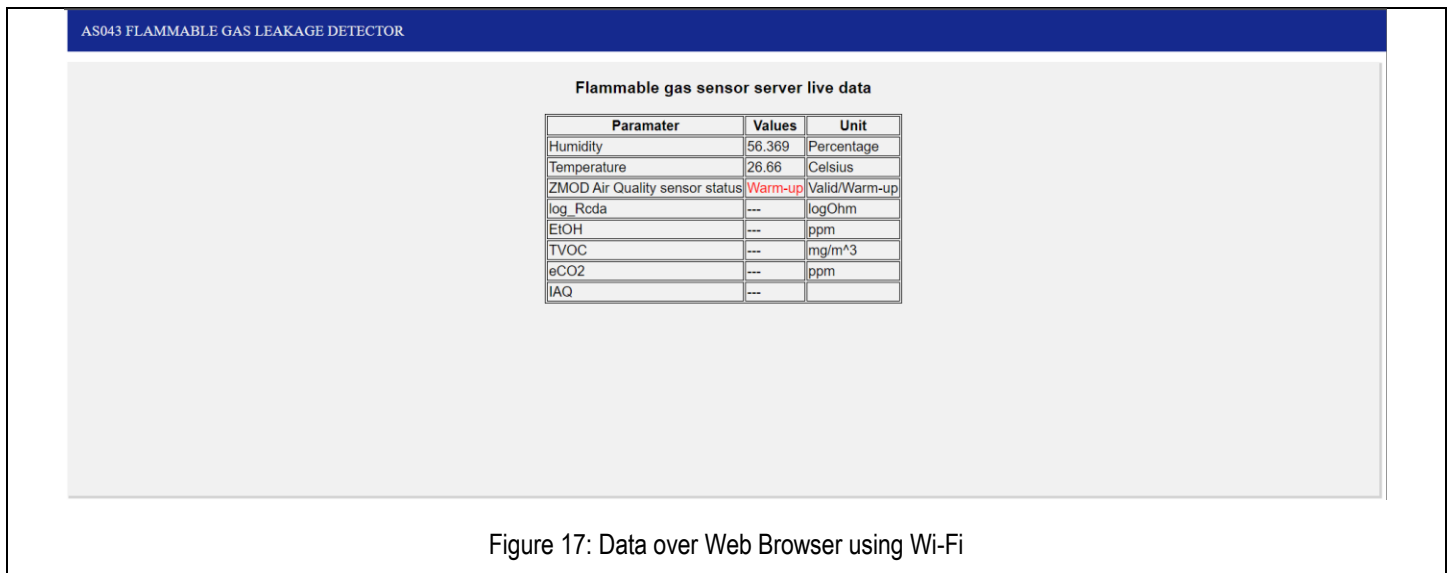

Figure 17: Data over Web Browser using Wi-Fi

The Renesas DA16200/16600 SDK is an enhanced software package designed to provide easy-to-use, scalable, high-quality software for embedded system designs using Renesas Wi-Fi/BLE family of Arm Microcontrollers. With the support of RTOS and other advanced security features, macro script based serial flashing provides a quick and versatile way to flash connected DA devices using production-ready drivers, Azure® RTOS, FreeRTOS™, and other middleware stacks.

Firmware (see below) for evaluating the functioning of the module is pre-loaded on the AS043- Flammable Gas Leakage Detector module. For firmware version please refer to the table below.

Firmware	DA16200 v3.2.2.0	Standard DA16200 SDK
----------	------------------	----------------------

Device Setup

Follow these procedures to set up the kit as shown on

1. Ensure AS043- Flammable Gas Leakage Detector evaluation module is powered with 2 x AAA battery
2. Make sure SW1 is in ON position.
3. As soon as the switch is turned on, the Blue and Green LED will start to blink.
4. Turn on the Wi-Fi on any device and connect to AS043_Gas_Sensor by providing the password. Password is: 12345678
5. After connecting the device to AS043_Gas_Sensor, open the browser and enter IP address as 192.168.1.1.
6. The Gas sensor live data will be displayed showing the values of Temperature and Humidity. The ZMOD4410 data will be displayed after the sensor warm-up is completed. The sensor warm-up takes ~62 seconds. The page displays the ZMOD4410 status as 'Warm-Up' for up to 62 seconds. During this warm-up time the green LED will be blinking. After 62 seconds it displays as 'Valid' and the green LED will be turned off, and the ZMOD sensor values like IAQ, EtOH, eCO2 and TVOC will be displayed.
7. Place the alcohol or any gas near the ZMOD4410 sensor to get the values. If the IAQ values exceed more than 3, the buzzer will provide the alarm, and the orange LED will be turned ON. These are a fault state.
8. The Gas Sensor live data will be displayed as shown below:

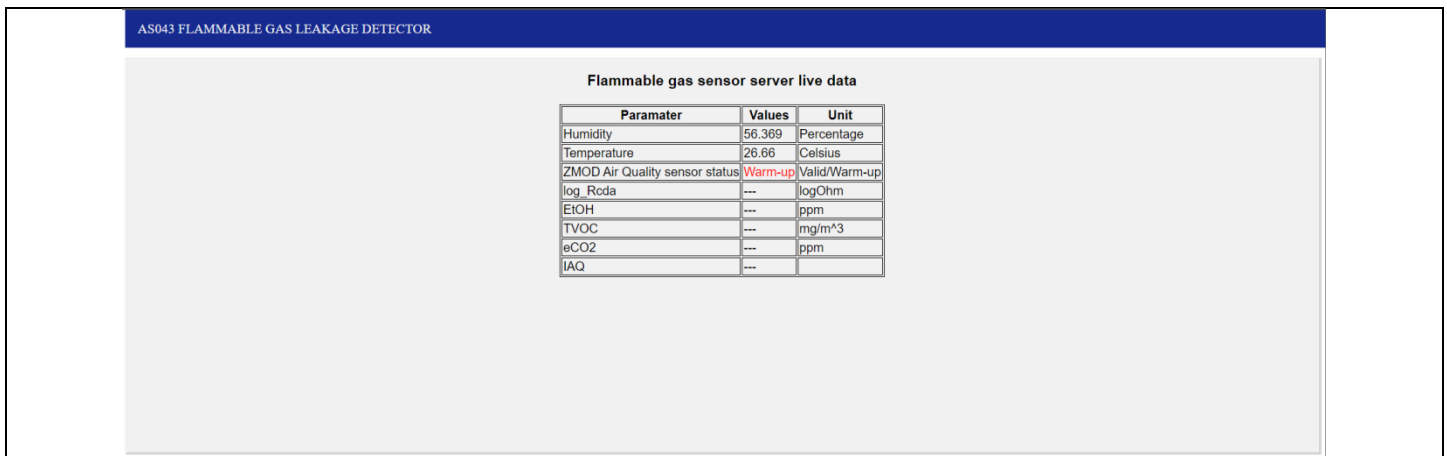

Figure 18: Data over Web Browser using Wi-Fi (Warmup)

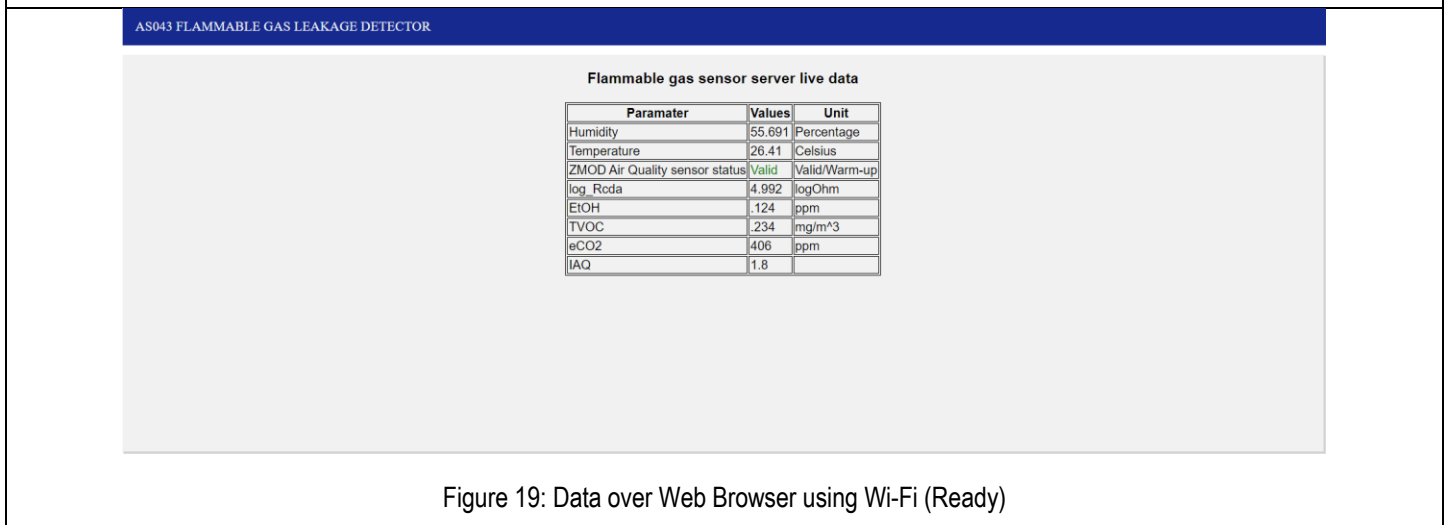

Figure 19: Data over Web Browser using Wi-Fi (Ready)

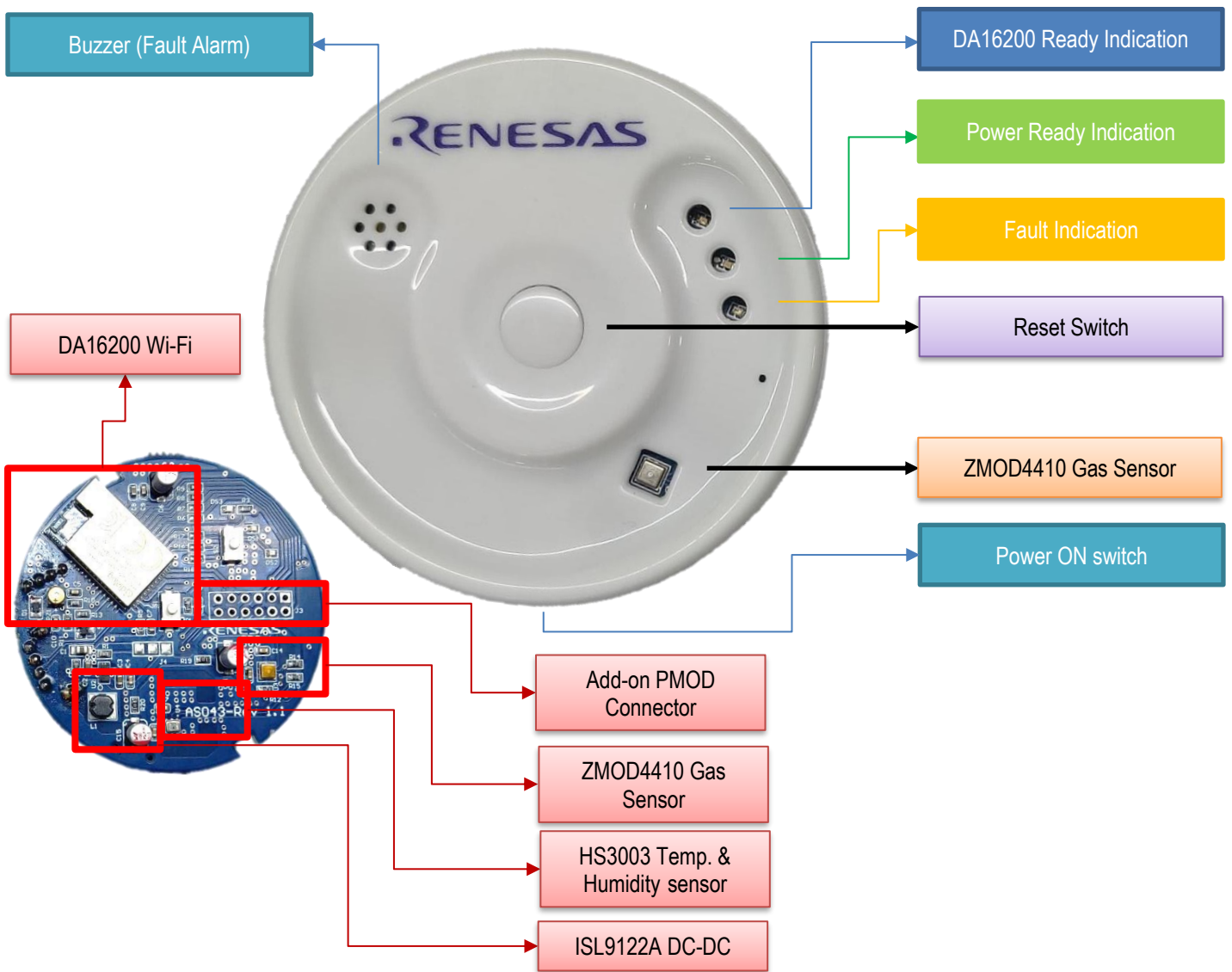

Figure 20: Evaluation Kit Details

AS043 Application Schematic

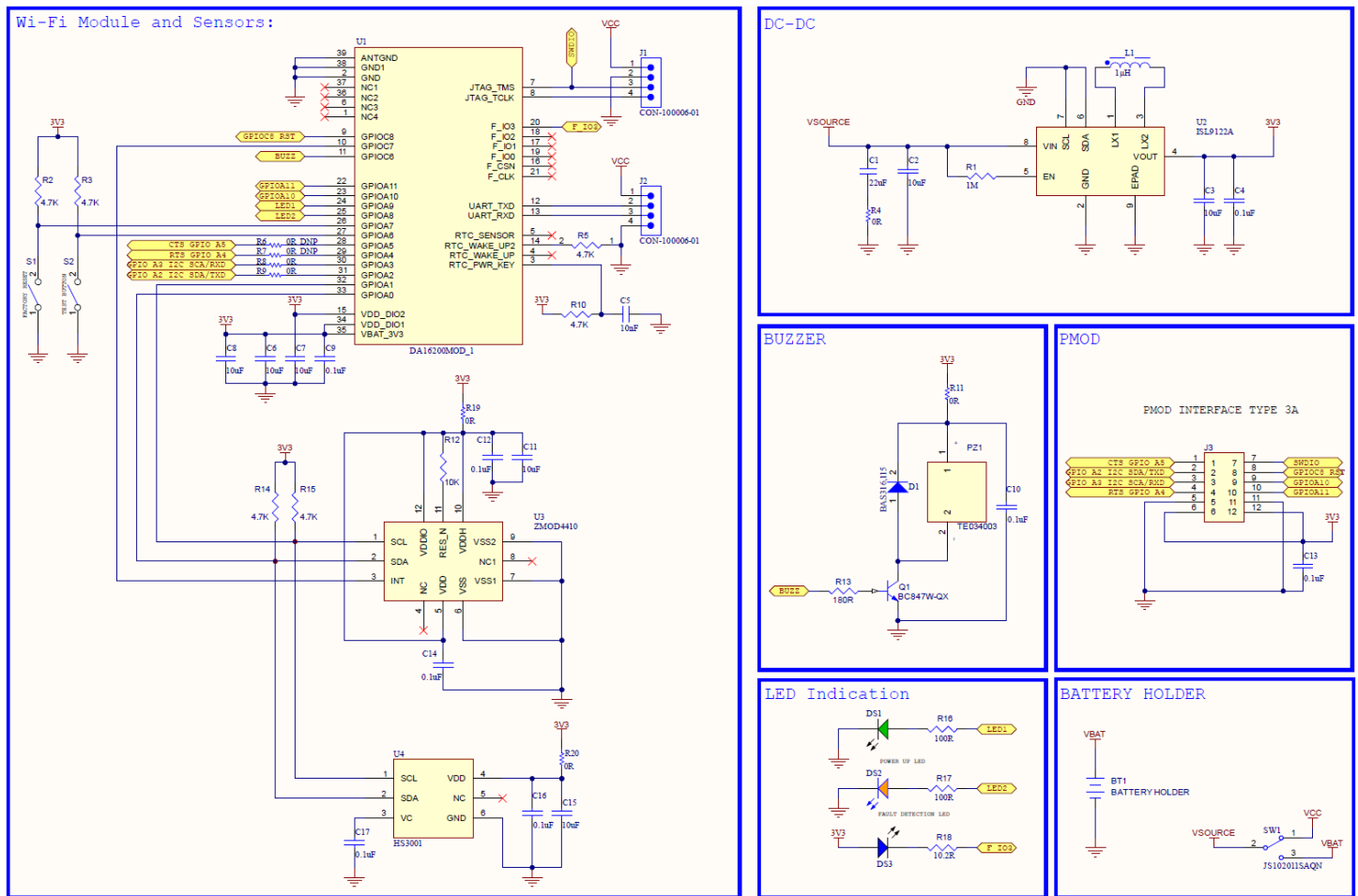

Figure 21: Schematic

Bill of Materials (BOM)

Table 1. AS043 BOM

Quantity	Designator	Description	Manufacturer	Manufacturer Part #
1	BT1	BATTERY HOLDER AAA 2 CELL PC PIN	Keystone Electronics	2468
1	C1	22 μ F \pm 20% 10V Ceramic Capacitor X5R 0805 (2012 Metric)	Würth Elektronik	885012107011
7	C2, C3, C6, C7, C8, C11, C15	10 μ F \pm 20% 25V Ceramic Capacitor X5R 0603 (1608 Metric)	Würth Elektronik	885012106031
7	C4, C9, C10, C12, C14, C16, C17	0.1 μ F \pm 10% 16V Ceramic Capacitor X7R 0603 (1608 Metric)	Würth Elektronik	885012206046
1	C5	10000 pF \pm 10% 16V Ceramic Capacitor X7R 0603 (1608 Metric)	Würth Elektronik	885012206040
1	D1	Diode Standard 100 V 250mA (DC) Surface Mount SOD-323	Nexperia USA Inc.	BAS316,115
1	DS1	Green 573nm LED Indication - Discrete 2V 0603 (1608 Metric)	Würth Elektronik	150060VS55040
1	DS2	Yellow 589nm LED Indication - Discrete 2V 0603 (1608 Metric)	Würth Elektronik	150060YS55040
1	DS3	Blue 470nm LED Indication - Discrete 3.2V 0603 (1608 Metric)	Würth Elektronik	150060BS75000
2	J1, J2	CONN HEADER VERT 4POS 2.54MM	Würth Elektronik	61300411121
1	L1	Inductor Power Shielded Wirewound 1uH 30% 100KHz Powdered Iron 1.75A 133mOhm DCR 1008 T/R	Würth Elektronik	74438322010
1	PZ1	Buzzers Transducer, Externally Driven Electromechanical 3 V 120mA 4kHz 64dB @ 3V, 10cm Surface Mount Solder Pads.	DB Unlimited	TE084003-1
1	Q1	Bipolar (BJT) Transistor NPN 45 V 100 mA 100MHz 200 mW Surface Mount SOT-323	Nexperia USA Inc.	BC847W-QX
1	R1	1 MOhms \pm 1% 0.1W, 1/10W Chip Resistor 0603 (1608 Metric) Moisture Resistant Thick Film.	YAGEO	RC0603FR-131ML
6	R2, R3, R5, R10, R14, R15	Chip Resistor, 4.7 KOhm, +/- 1%, 0.1 W, -55 to 155 degC, 0603 (1608 Metric)	YAGEO	RC0603FR-134K7L
6	R4, R8, R9, R11, R19, R20	Chip Resistor, 0 Ohm, 0.1 W, -55 to 155 degC, 0603 (1608 Metric)	YAGEO	RC0603JR-070RL
1	R12	Chip Resistor, 10 KOhm, +/- 1%, 01 W, -55 to 155 degC, 0603 (1608 Metric)	YAGEO	RC0603FR-0710KL
1	R13	180 Ohms \pm 1% 0.1W, 1/10W Chip Resistor 0603 (1608 Metric) Moisture Resistant Thick Film	YAGEO	RC0603FR-07180RL
2	R16, R17	100 Ohms \pm 1% 0.1W, 1/10W Chip Resistor 0603 (1608 Metric) Moisture Resistant Thick Film	YAGEO	RC0603FR-10100RL
1	R18	10.2 Ohms \pm 1% 0.1W, 1/10W Chip Resistor 0603 (1608 Metric) Moisture Resistant Thick Film	YAGEO	RC0603FR-0710R2L
2	S1, S2	Tactile Switch SPST-NO Top Actuated Surface Mount	Würth Elektronik	434111025826
1	SW1	Slide Switch SPDT Surface Mount, Right Angle	C&K	JS102011SAQN
1	U1	DA16200 WIFI MODULE CHIP ANTENNA	Renesas	DA16200MOD-AAC4WA32
1	U2	ULTRA-LOW IQ BUCK-BOOST REGULATO	Renesas	ISL9122AIRNZ-T
1	U3	Gas Sensor Module for TVOC and Indoor Air Quality	Renesas	ZMOD4410
1	U4	High Performance Relative Humidity and Temperature Sensor	Renesas	HS3003

Board Layout

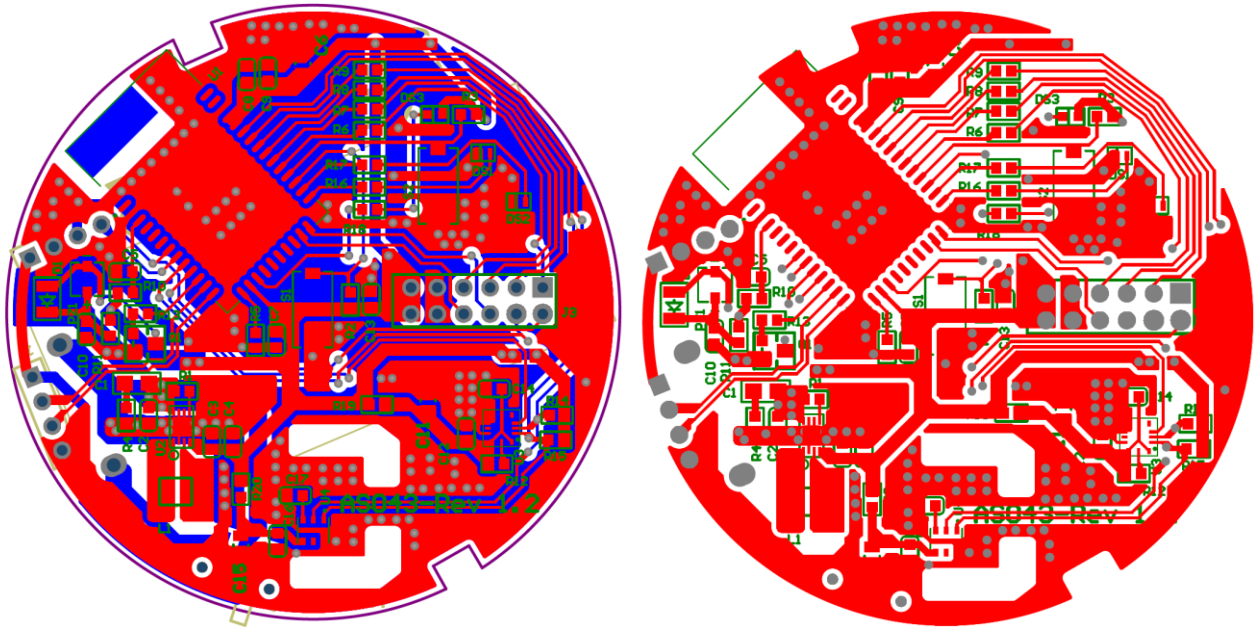

Figure 22: Top and Bottom Layout