

P9025AC-R-EVK V1.0

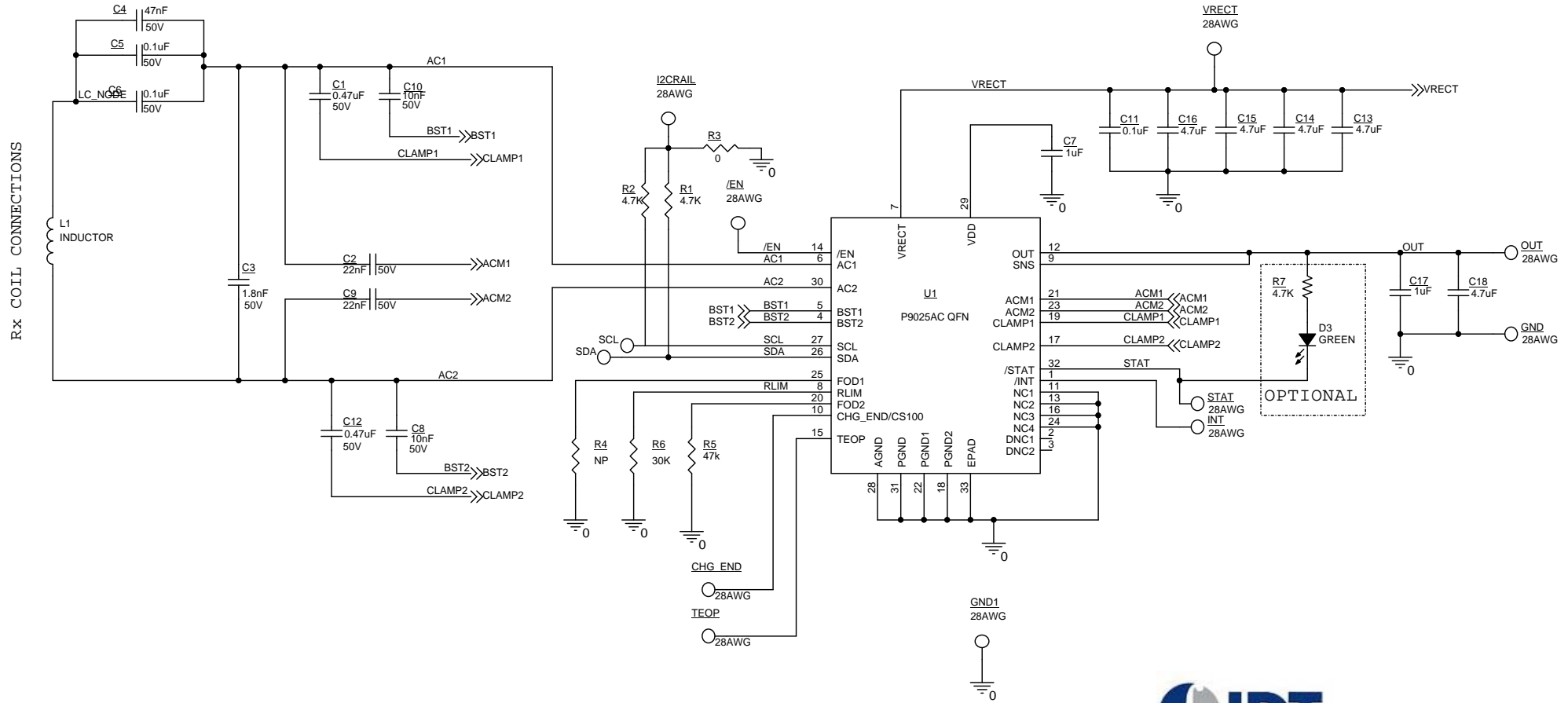

NOTES:

- 1.FOD1 (R4) is for selecting internal OTP settings and FOD2 (R5) is for adding offset to the FOD1 setting. Values will be determined during pre-production.
2. I2C pins must not float (Pull-up or Pull-down).
3. Connections for programming FOD settings and reading I2C: Vrect, /EN, SDA, SCL, GND.
4. TEOP and CHG_END/CS100 inputs may be directly connected to GND if these functions are not required.



THIS DOCUMENT CONTAINS INFORMATION PROPRIETARY TO Integrated Device Technology, Inc. (IDT). USE OR DISCLOSURE WITHOUT THE WRITTEN PERMISSION OF AN OFFICER OF IDT IS EXPRESSLY FORBIDDEN

Title		
P9025AC-R-EVK V1.0		
Size	Document Number	Rev
Custom	305-PD-15-0285	1
Date:	Tuesday, August 04, 2015	Sheet 2 of 2