

Description

The IDT P9221-R-EVK Mass-Market (MM) Evaluation Board demonstrates the features and performance of the P9221-R 15W Wireless Power Receiver (Rx). The P9221-R-EVK offers the flexibility to program parameters, such as the output voltage, over-current limit threshold, and external temperature sensing function. It also allows tuning the Foreign Object Detection (FOD) feature by varying values in the resistor divider connected to the VOSET/Q-Fact pin.

The P9221-R-EVK MM Evaluation Board is designed to function as the receiver in a wireless power transfer system using IDT's P9242-R-EVK MM Evaluation Board as the power transmitter. The P9242-R-EVK is ordered separately. The P9221-R-EVK can also be used with the user's WPC-1.2 compliant transmitter.

The high-efficiency, turnkey reference design is supported by comprehensive online, digital resources to significantly expedite design-in effort and enable rapid prototyping. The printed circuit board (PCB) has four layers. The total active area is optimized to 28mm x 15mm.

Kit Contents

- P9221-R-EVK Mass-Market Evaluation Board

Features

- P9221-R-EVK MM Evaluation Board supports WPC-1.2
- Up to 15W output power
- Selectable output voltage: 12V or 9V
- Adjustable over-current limit
- External FOD tuning
- Power transfer LED indicator
- Alignment guide information using the PCB coils
- 4-layer PCB
- Total active area: 420mm²
- Fully assembled with test points and coil fixture

P9221-R-EVK MM Evaluation Board

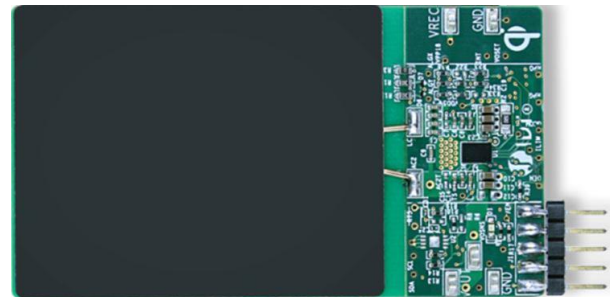

Wireless Power Transfer System using the P9221-R-EVK and P9242-R-EVK

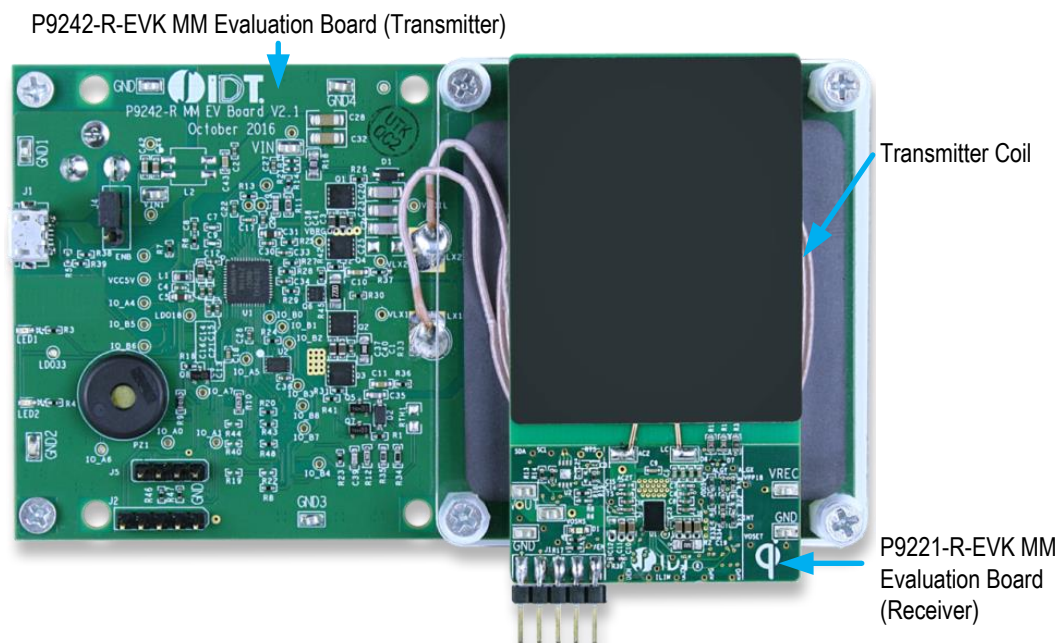

Important Notes

Disclaimer

Integrated Device Technology, Inc. and its affiliated companies (herein referred to as “IDT”) shall not be liable for any damages arising out of defects resulting from

- (i) delivered hardware or software
- (ii) non-observance of instructions contained in this manual and in any other documentation provided to user, or
- (iii) misuse, abuse, use under abnormal conditions, or alteration by anyone other than IDT.

TO THE EXTENT PERMITTED BY LAW, IDT HEREBY EXPRESSLY DISCLAIMS AND USER EXPRESSLY WAIVES ANY AND ALL WARRANTIES, WHETHER EXPRESS, IMPLIED, OR STATUTORY, INCLUDING, WITHOUT LIMITATION, IMPLIED WARRANTIES OF MERCHANTABILITY AND OF FITNESS FOR A PARTICULAR PURPOSE, STATUTORY WARRANTY OF NON-INFRINGEMENT, AND ANY OTHER WARRANTY THAT MAY ARISE BY REASON OF USAGE OF TRADE, CUSTOM, OR COURSE OF DEALING.

Restrictions in Use

IDT’s P9221-R-EVK Mass Market Evaluation Board is designed for evaluation purposes only. It must not be used for module production or production test setups.

Contents

1. Setup	4
1.1 Required or Recommended User Equipment.....	4
1.2 Kit Hardware Connections	4
2. Usage Guide.....	5
2.1 Overview of the P9221-R-EVK	5
2.2 Setting the Output Voltage and Reference Q-factor Value – VOSET/Q-Fact Pin	6
2.3 Alignment Aid – ALIGNX and ALIGNY	7
2.4 Adjustment of Over-Current Limit	8
2.5 External Temperature Sensing and End of Charge – TS/EOC	9
2.6 Receiver Coil	10
3. P9221-R-EVK MM Evaluation Board Schematics	11
4. Bill of Materials (BOM).....	12
5. Board Layout	14
6. Ordering Information.....	17
7. Revision History.....	17

List of Figures

Figure 1. Evaluation Kit Setup using the P9242-R-EVK MM Evaluation Board as the Transmitter	4
Figure 2. P9221-R-EVK MM Evaluation Board V2.2 Features	5
Figure 3. R33 and R34 Locations	6
Figure 4. Recommended Structure of the X-Y Alignment Coil.....	7
Figure 5. R38 and R22 Location.....	8
Figure 6. Over-Current Limit vs. ILIM Pin Voltage	9
Figure 7. Optional External Temperature Sensing by Connecting an RTS Thermistor	10
Figure 8. Silkscreen – Top of Board	14
Figure 9. Silkscreen – Bottom of Board	14
Figure 10. Top Copper Layer.....	15
Figure 11. L2 Copper Layer.....	15
Figure 12. L3 Copper Layer.....	16
Figure 13. Bottom Copper Layer	16

List of Tables

Table 1. Setting the Output Voltage and Reference Q-factor Value.....	6
Table 2. Setting the Over-Current Limit.....	8
Table 3. Recommend Coil Manufacturers	10
Table 4. P9221-R-EVK MM Evaluation Board BOM V2.2	12

1. Setup

1.1 Required or Recommended User Equipment

The following additional lab equipment is required for using the kit:

- P9242-R-EVK MM Evaluation Board or any WPC-1.2 compliant transmitter
- Power supply or 12V/2A AC adaptor

1.2 Kit Hardware Connections

Follow these procedures to set up the kit as shown in Figure 1:

1. Set up the P9242-R-EVK Evaluation Board (or user transmitter) according to the board's user manual.
2. Place the P9221-R-EVK on the transmitter (TX) pad with the components facing up as shown in Figure 1.
3. Verify that the green LEDs on both boards are illuminated indicating that coupling has been established.
4. Connect wires to the VOUT and GND test points to measure the output voltage and apply a load.

Figure 1. Evaluation Kit Setup using the P9242-R-EVK MM Evaluation Board as the Transmitter

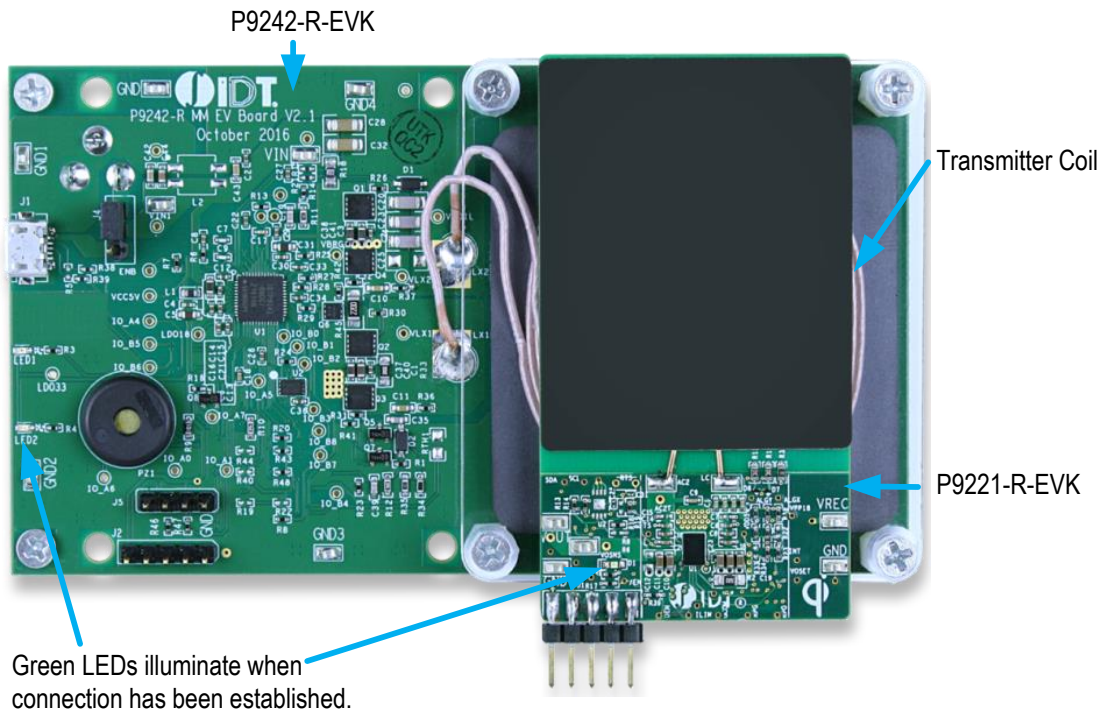

2. Usage Guide

2.1 Overview of the P9221-R-EVK

Figure 2. P9221-R-EVK MM Evaluation Board V2.2 Features

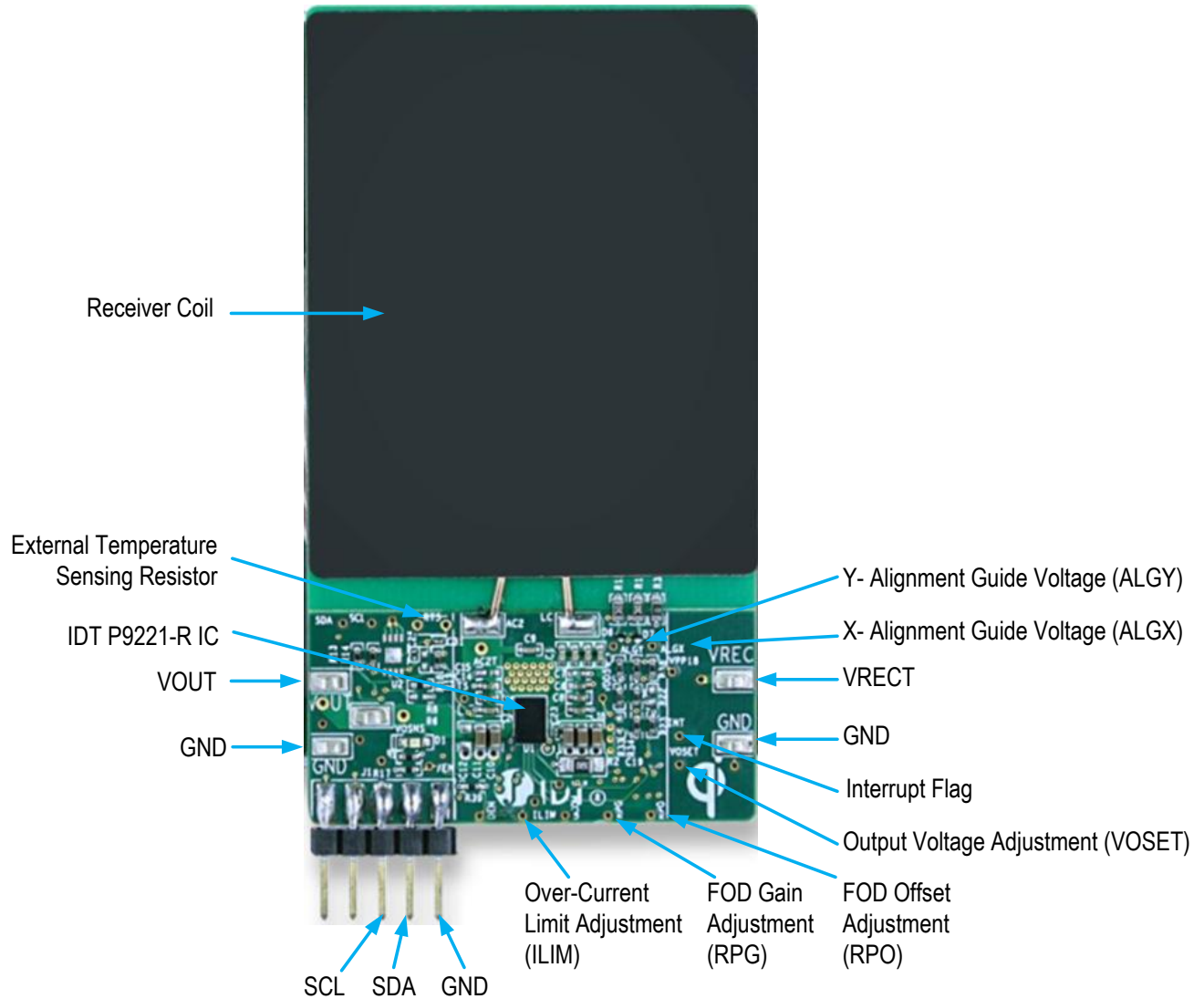

2.2 Setting the Output Voltage and Reference Q-factor Value – VOSET/Q-Fact Pin

The output voltage on the P9221-R is programmed by connecting the center tap of the divider network comprising external resistors R34 and R33 to the VOSET/Q-Fact pin as shown in the schematic in section 3. The output voltage can be set to 9V or 12V. The recommended settings for R33 and R34 are given in Table 1.

The default output voltage is set to 12V on the P9221-R-EVK MM Evaluation Board (R34 = 10kΩ; R33 = open). For applications where the transmitter is capable of delivering only 5W, the P9221-R will automatically switch to 5V output to ensure 5W power delivery. The 5W option can be disabled by changing R33 as described in Table 1. In this case, if the receiver is placed on a 5W transmitter, the receiver output pin will be high impedance.

The VOSET/Q-Fact pin also allows setting the Q-factor value by adjusting R34 and R33 as shown in Table 1. The default value is set to 103 on the P9221-R-EVK MM Evaluation Board. For development purposes, the Q-factor should be set to 20 to avoid prematurely triggering the Q-factor.

Table 1. Setting the Output Voltage and Reference Q-factor Value

Note: The default values on the P9221-R-EVK are indicated with blue shading.

Q Factor Value Setting	VOUT Setting (R34/R33 Values)							
	9V without 5V		9V with 5V		12V without 5V		12V with 5V	
	R34	R33	R34	R33	R34	R33	R34	R33
103	10kΩ	4.87kΩ	Open	10kΩ	10kΩ	21kΩ	10kΩ	Open
80	10kΩ	4.32kΩ	10kΩ	0.31kΩ	10kΩ	22.6kΩ	10kΩ	324kΩ
60	10kΩ	3.65kΩ	10kΩ	0.681kΩ	10kΩ	27.4kΩ	10kΩ	147kΩ
40	10kΩ	3.09kΩ	10kΩ	1.1kΩ	10kΩ	32.4kΩ	10kΩ	90.9kΩ
20	10kΩ	2.55kΩ	10kΩ	1.54kΩ	10kΩ	39.2kΩ	10kΩ	64.9kΩ

Figure 3. R33 and R34 Locations

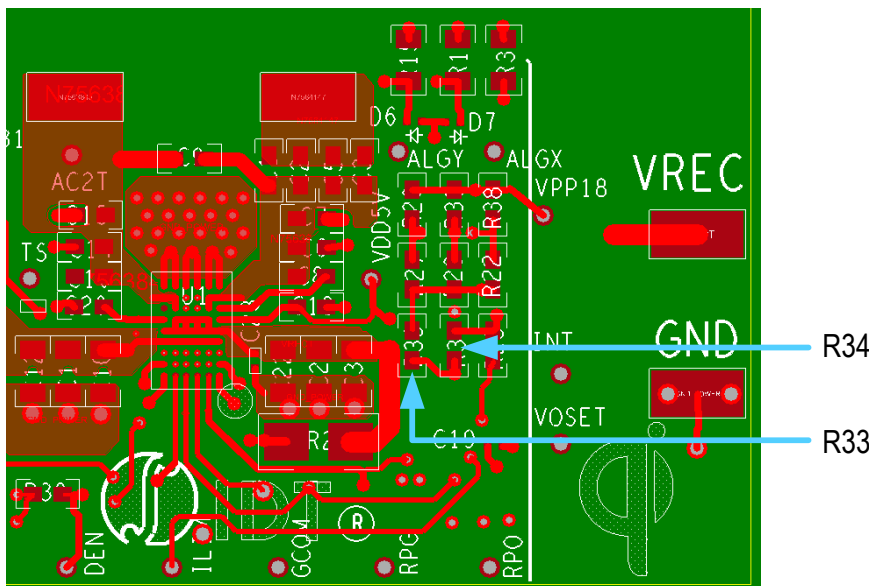

2.3 Alignment Aid – ALIGNX and ALIGNY

The signal magnitude on the P9221-R's ALIGNX and ALIGNY pins provides directional alignment information by measuring the phase between the input power AC signal and the horizontal (ALIGNX) and vertical (ALIGNY) alignment signals. After the signal is measured by the analog-to-digital converter, the alignment information is represented by two 8-bit signed numbers, which can be read via the I2C interface from the *Align_X* and *Align_Y* registers (see the *P9221-R Datasheet*).

The difference in the electromotive force (EMF) voltage of the two coils can be represented by the amount of magnetic flux, which depends on the misalignment position of the receiver coil relative to the transmitter coil. With the combination of two symmetrical coils on the vertical (Y) axis and horizontal (X) axis, it is possible to sense alignment in two dimensions as shown in Figure 4. The trace length and width were designed with 452.12mm and 0.254mm respectively for each segment coil on the P9221-R-EVK MM Evaluation Board, which was assembled with the AMOTECH ASC-504060E00-S00 coil as shown in Figure 4.

Figure 4. Recommended Structure of the X-Y Alignment Coil

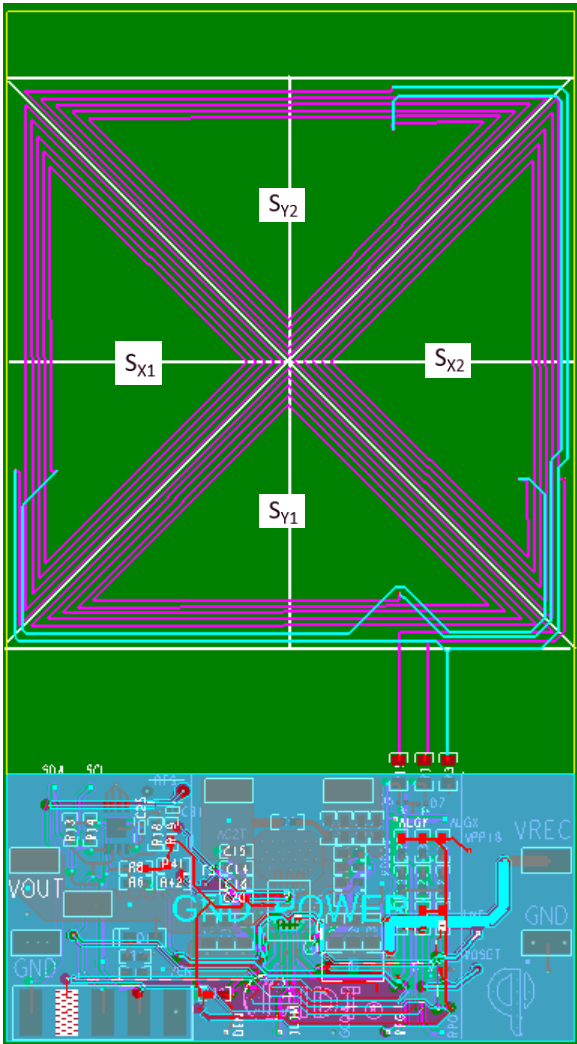

2.4 Adjustment of Over-Current Limit

The P9221-R has a programmable current limit function for protecting the device in the event of an over-current or short-circuit fault condition. If the output current exceeds the programmed threshold, the P9221-R will limit the load current by reducing the output voltage. The recommended current limit setting is 120% of the maximum output current. The default value for the over-current limit is set to 1.6A. The ILIM pin allows changing the over-current limit value without modification of the firmware by selecting the values of R38 and R22 as shown in Table 2. R38 and R22 form a divider network from the 1.8V supply to ground with the center tap connected to the ILIM pin as shown in the schematic in section 3. The voltage at the ILIM pin sets the over-current limit. See Figure 6 for the relationship between the current limit and the voltage on the ILIM pin.

Table 2. Setting the Over-Current Limit

Note: The default values on the P9221-R-EVK are indicated with blue shading.

Voltage on ILIM Pin [V]	R38 [kΩ]	R22 [kΩ]	Maximum Output Current [A]	Over-Current Limit [A]
Pull-up	10	Open	1.25	1.6
0.60	10	5.1	0.80	1
0.45	10	3.3	0.64	0.8
0.25	10	1.6	0.40	0.5

Figure 5. R38 and R22 Location

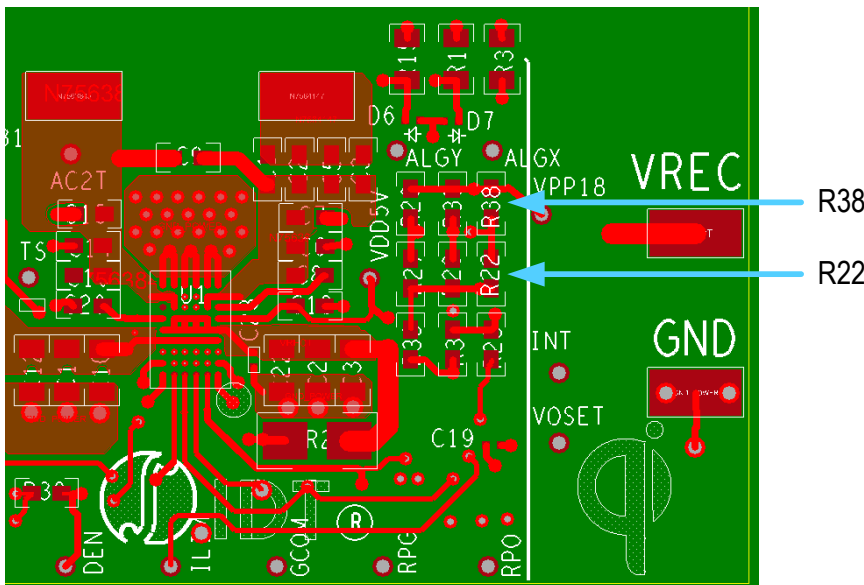
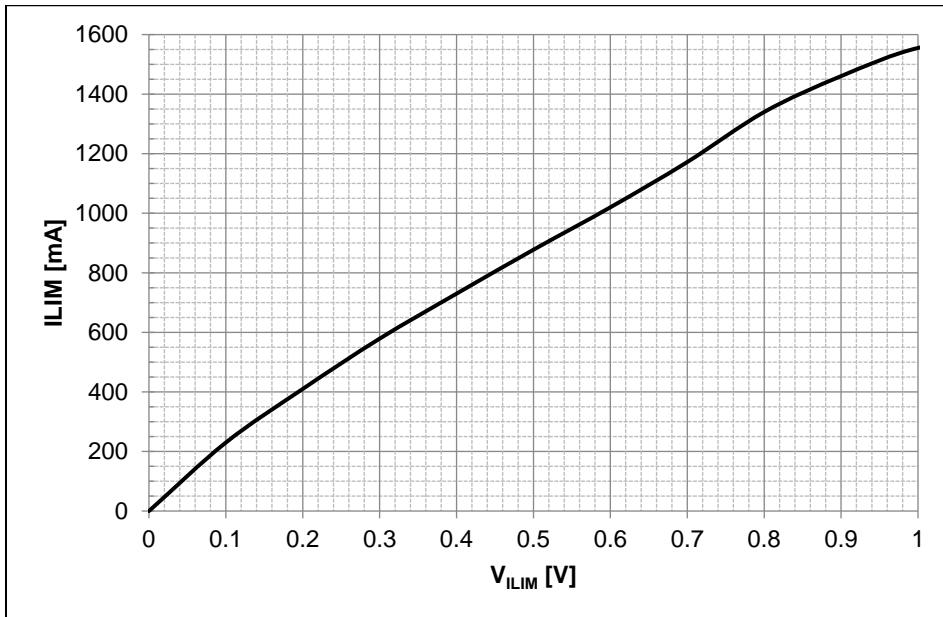

Figure 6. Over-Current Limit vs. ILIM Pin Voltage



2.5 External Temperature Sensing and End of Charge – TS/EOC

The P9221-R has a temperature sense input pin, TS, which can be used to monitor a remote temperature, such as a thermistor reading for a coil or a battery charger. The built-in comparator’s reference voltage is 0.6V and 0.1V in the P9221-R, and it is used for monitoring the voltage level on the TS/EOC pin as described by Equation 1.

$$V_{TS} = V_{VDD18} * \frac{NTC}{R19 + NTC}$$

Equation 1

Where NTC is the thermistor’s resistance and R19 is the pull-up resistor connected to the 1.8V supply voltage on the P9221-R-EVK MM Evaluation Board. The over-temperature shutdown is triggered when the TS pin voltage is between 0.6V and 0.1V. The RTS is not populated on the P9221-R MM Evaluation Board.

When the TS/EOC pin is less than 0.1V, the End-of-Charge (EOC) function is activated, and the P9221-R will send the End-Power-Transfer (EPT) packet to the transmitter terminating the power delivery.

Figure 7. Optional External Temperature Sensing by Connecting an RTS Thermistor

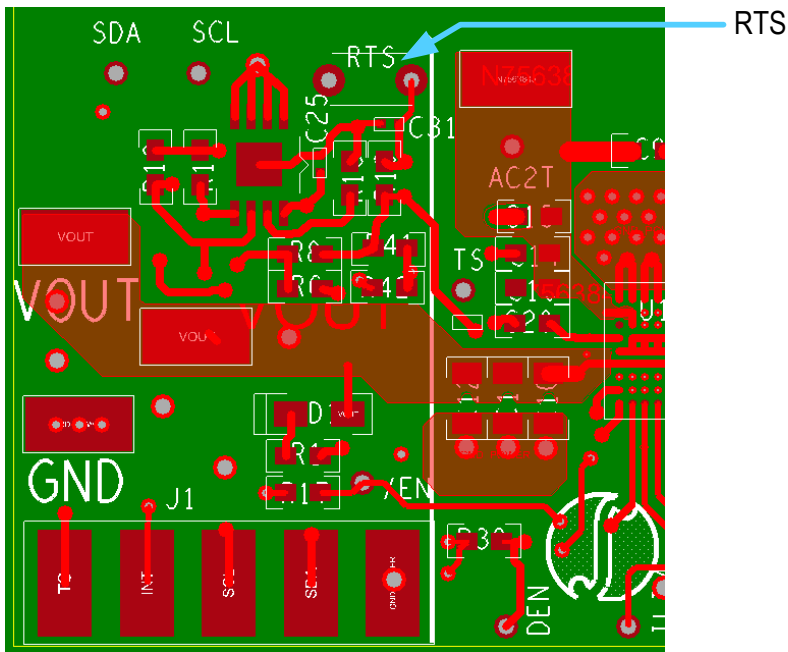

2.6 Receiver Coil

The ASC-504060E00-S00 coil is used in the kit. The following alternative coils are recommended for the P9221-R receiver for 15W applications for optimum performance. The recommended vendor coils have been tested and verified as shown in Table 3.

Table 3. Recommend Coil Manufacturers

Output Power	Vendor	Part Number	Inductance at 100kHz	ACR at 20°C	Series Resonant Capacitance
15W	AMOTECH	ASC-504060E00-S00	8.2μH	220mΩ	400nF
15W	TDK	WR424245-13K2-G	11.2μH	170mΩ	300nF
15W	SUNLORD	SWA50R40H06C02B	8.4μH	150mΩ	400nF
15W	WURTH	760308102207	8.0μH	80mΩ	400nF

3. P9221-R-EVK MM Evaluation Board Schematics

P9221-R MM EV Board V2.2

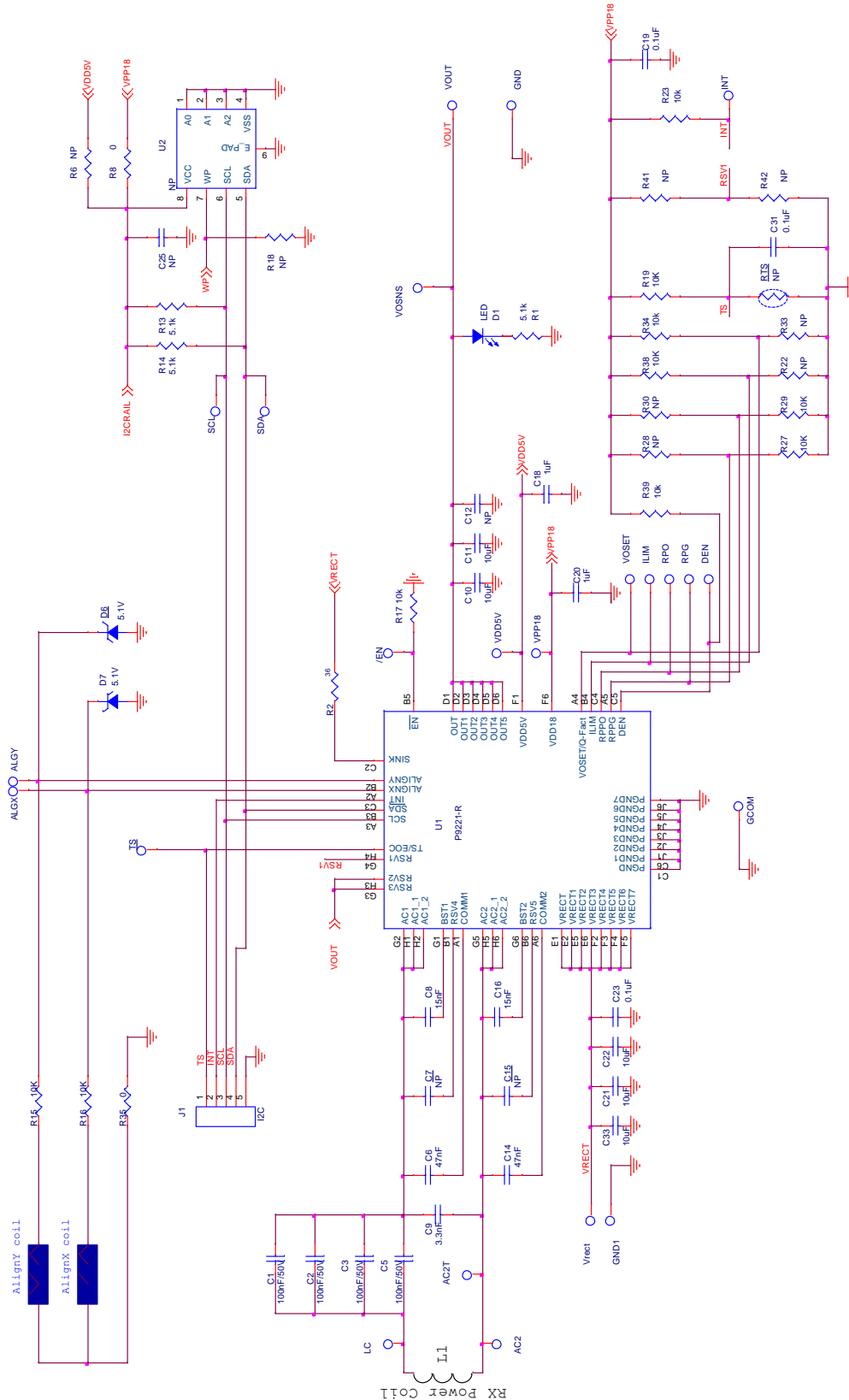

4. Bill of Materials (BOM)

Table 4. P9221-R-EVK MM Evaluation Board BOM V2.2

Item	Reference	Quantity	Value	Description	Part number	PCB Footprint
1	AC2T, VDD5V, VPP18, VOSET, TS, SDA, SCL, RPO, RPG, INT, ILIM, GCOM, DEN, ALGY, ALGX, /EN	16	PTH_TP	Test Pad		10MIL_35PAD
2	AC2, LC	2	NP	TEST POINT		test_pt_sm_135x70
3	C1, C2, C3, C5	4	100nF	CAP CER 0.1μF 50V X5R 0402	GRM155R61H104KE19D	0402
4	C6, C14	2	47nF	CAP CER 0.047μF 50V X7R 0402	C1005X7R1H473K050BB	0402
5	C7, C15	2	NP	CAP CER 0.047μF 50V X7R 0402	C1005X7R1H473K050BB	0402
6	C8, C16	2	15nF	CAP CER 0.015μF 50V X7R 0402	GRM155R71H153KA12J	0402
7	C9	1	3.3nF	CAP CER 3300PF 50V X7R 0402	CL05B332KB5NNNC	0402
8	C10, C11, C21, C22, C33	5	10μF	CAP CER 10μF 25V X5R 0603	CL10A106MA8NRNC	0603
9	C12	1	NP	CAP CER 10μF 25V X5R 0603	CL10A106MA8NRNC	0603
10	C18,C20	2	1μF	CAP CER 1μF 10V X5R 0402	GRM155R61A105KE15D	0402
11	C19,C31	2	0.1μF	CAP CER 0.1μF 10V X5R 0201	C0603X5R1A104K030BC	0201
12	C23	1	0.1μF	CAP CER 0.1μF 25V X5R 0201	CL03A104KA3NNNC	0201
13	C25	1	NP	CAP CER 0.1μF 10V X5R 0201	C0603X5R1A104K030BC	0201
14	D1	1	LED	LED GREEN CLEAR 0603 SMD	150 060 GS7 500 0	0603_diode
15	D6,D7	2	5.1V	DIODE ZENER 5.1V 100MW 0201	CZRZ5V1B-HF	0201
16	GND1, VRECT, VOUT, VOSNS, GND	5	Test Point	TEST POINT PC MINIATURE SMT	5015	test_pt_sm_135x70
17	J1	1	I ² C	HEADER_1X5_0P1PITCH60P42D	68002-205HLF	header_1x5_0p1Pit ch60p42d
18	L1	1	8.2μH	Wireless power receiver coil	ASC-504060E00-S00	sm_135x70
19	RTS	1	NP			NTC2
20	R1, R13, R14	3	5.1kΩ	RES SMD 5.1K OHM 5% 1/16W 0402	MCR01MRTJ512	0402
21	R2	1	36Ω	RES SMD 36 OHM 5% 1/2W 0805	ERJ-P06J360V	0805
22	R6	1	NP	RES SMD 0.0OHM JUMPER	ERJ-2GE0R00X	0402
23	R8	1	0Ω	RES SMD 0.0OHM JUMPER 1/10W 0402	ERJ-2GE0R00X	0402
24	R15, R16	2	10KΩ	RES SMD 10K OHM 1% 1/10W 0603	RC0603FR-0710KL	0603

Item	Reference	Quantity	Value	Description	Part number	PCB Footprint
25	R17, R19, R23, R27, R29, R34, R38, R39	8	10k Ω	RES SMD 10K OHM 5% 1/16W 0402	CRCW040210K0JNEDIF	0402
26	R18, R22, R28, R30, R33, R41, R42	7	NP	RES SMD 10K OHM 5% 1/16W 0402	CRCW040210K0JNEDIF	0402
27	R35	1	0 Ω	RES SMD 0.0OHM 1/10W 0603	MCR03EZPJ000	0603
28	U1	1	P9221-R	MP Wireless power receiver	P9221-R	csp52_2p64x3p94_0p4mm
29	U2	1	NP	IC EEPROM 128KBIT 400KHZ 8TDFN	24AA128T-I/MNY	TDFN08

5. Board Layout

Figure 8. Silkscreen – Top of Board

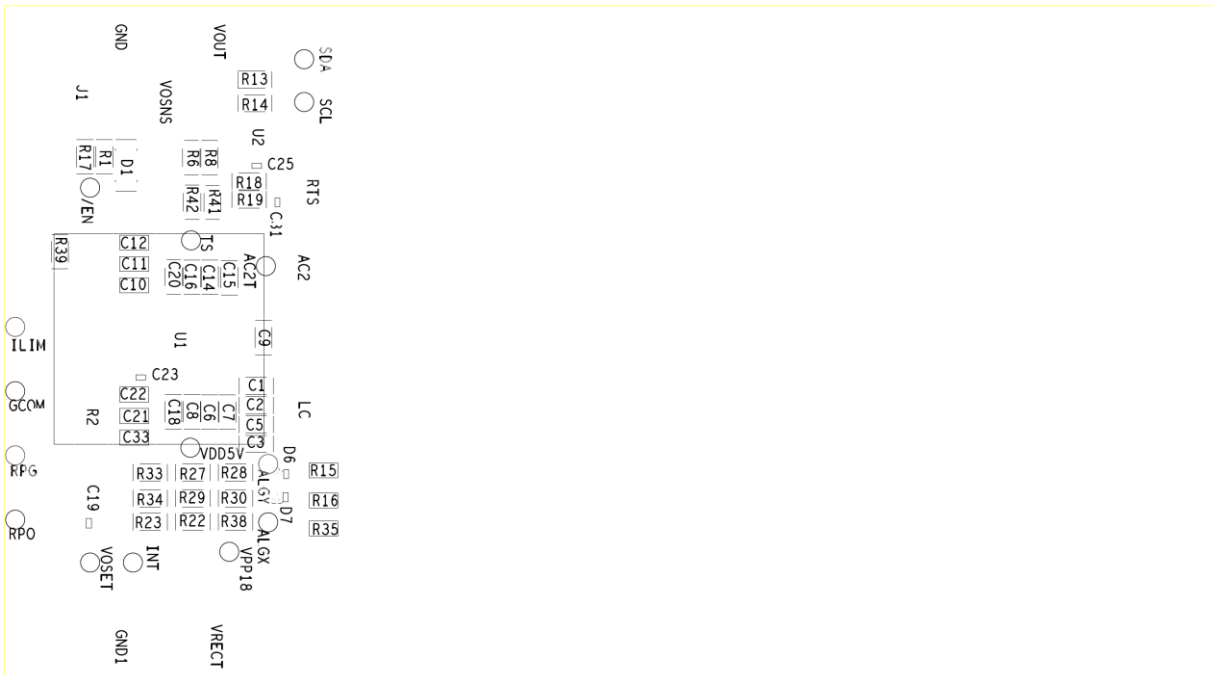

Figure 9. Silkscreen – Bottom of Board

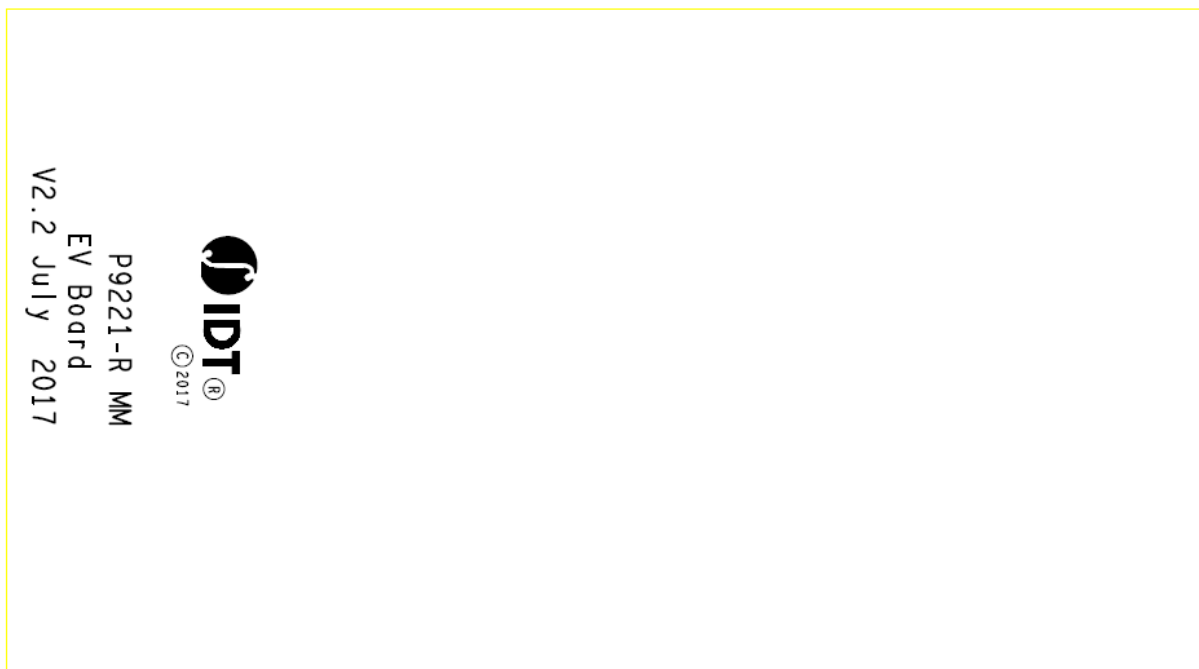

Figure 10. Top Copper Layer

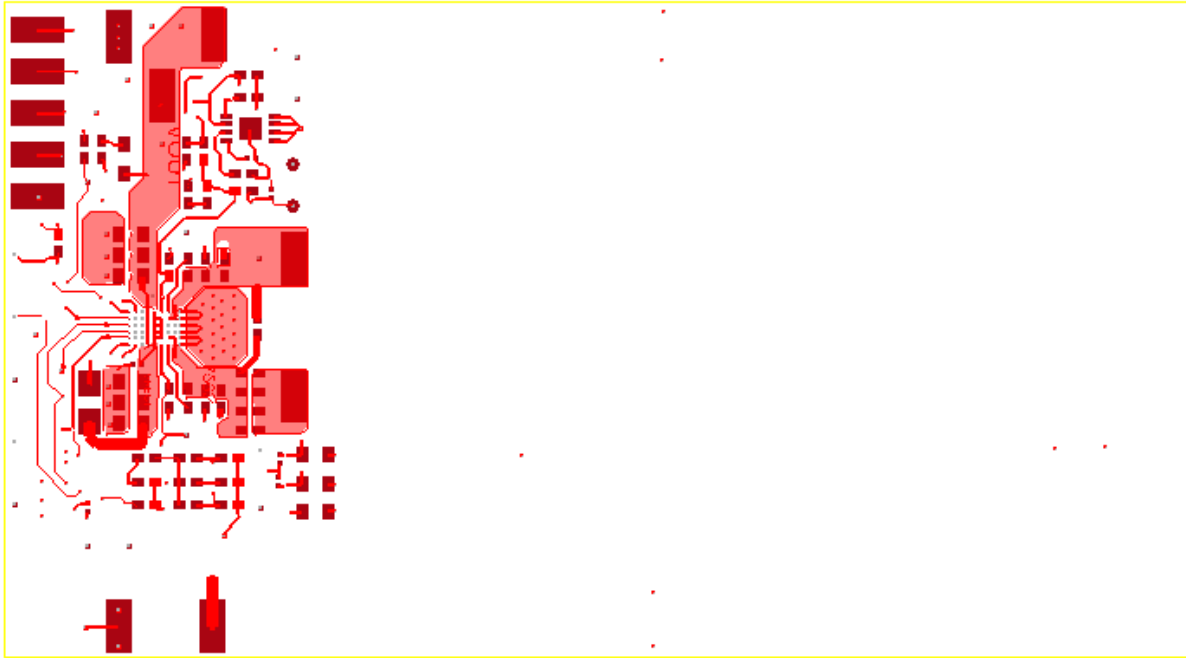

Figure 11. L2 Copper Layer

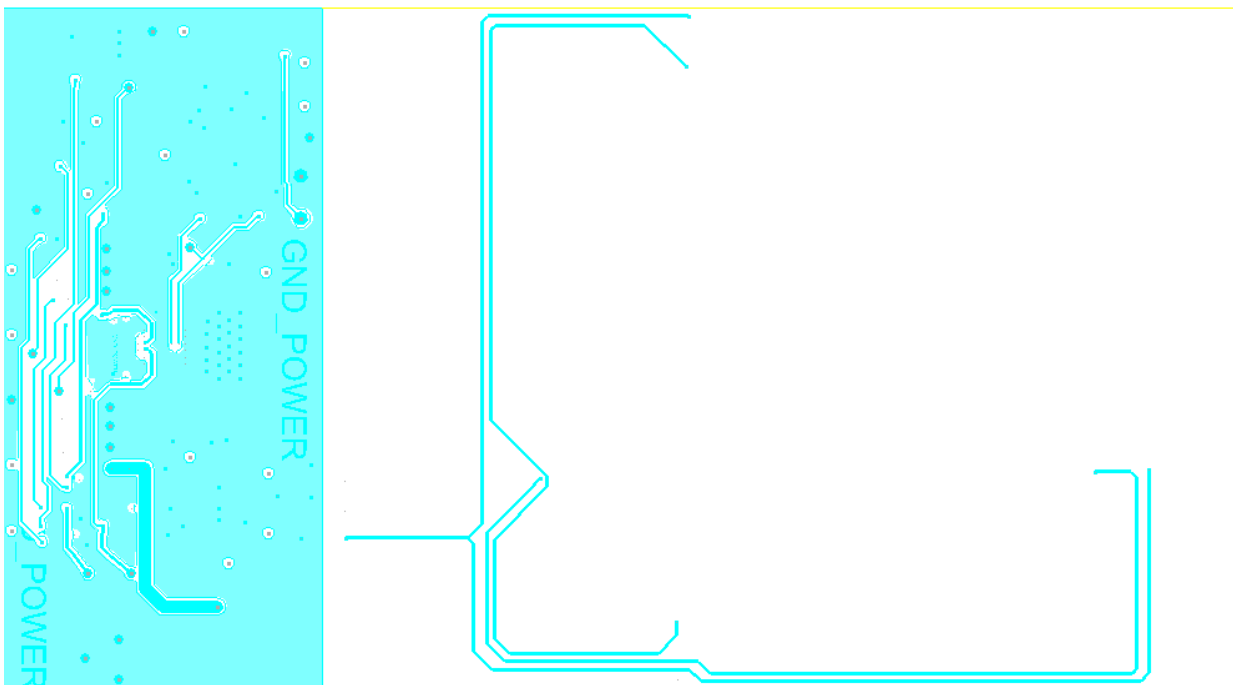

Figure 12. L3 Copper Layer

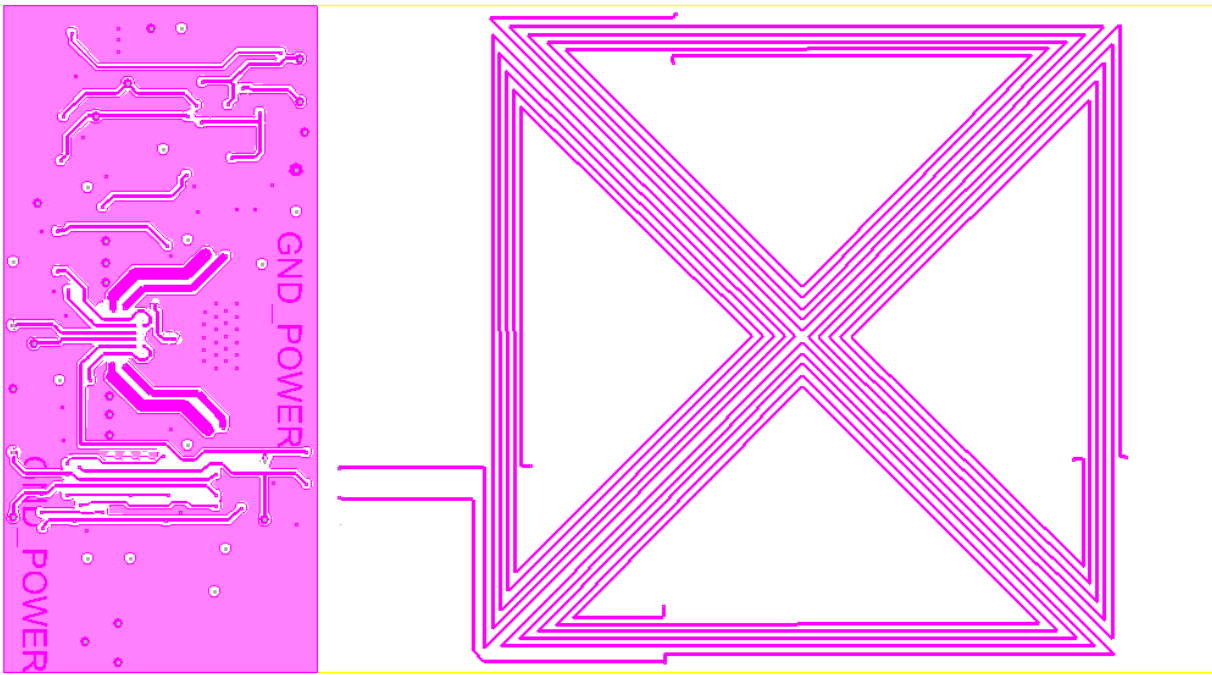
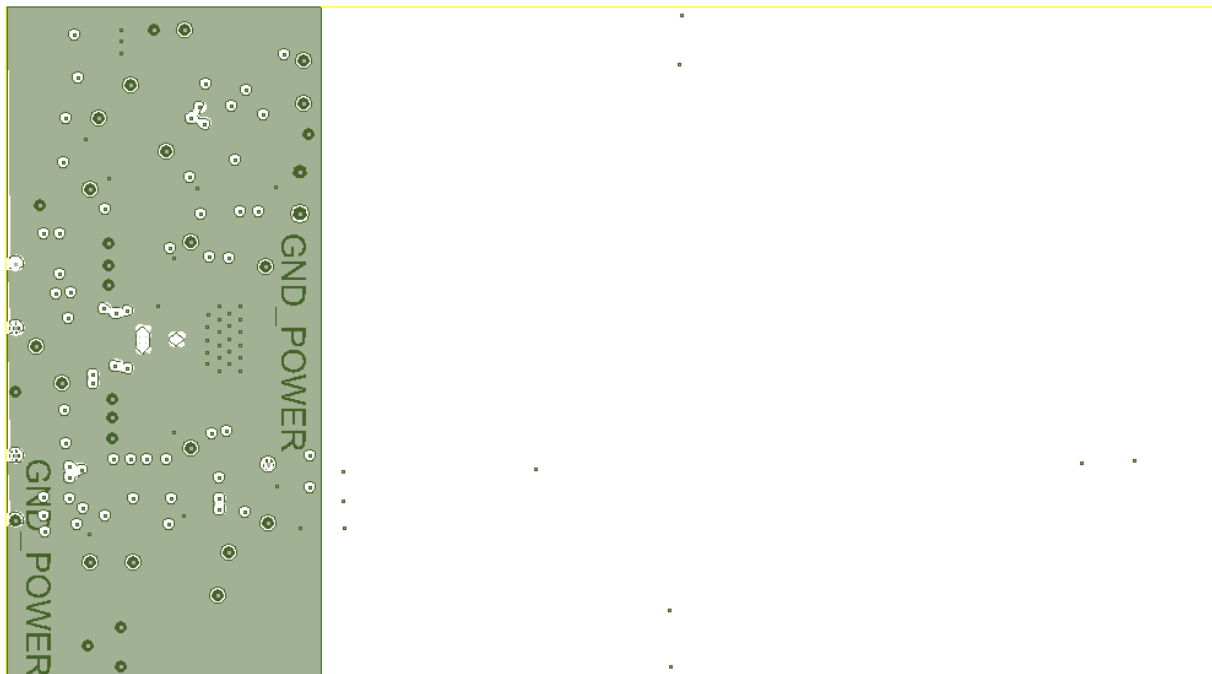

Figure 13. Bottom Copper Layer



6. Ordering Information

Orderable Part Number	Description
P9221-R-EVK	P9221-R-EVK MM Evaluation Board

7. Revision History

Revision Date	Description of Change
December 18, 2017	<ul style="list-style-type: none"><li data-bbox="435 604 862 636">▪ Updates for V2.2 of the P9221-R-EVK.<li data-bbox="435 646 586 678">▪ Minor edits.
December 19, 2016	Initial release of document.

