

RL78 Family

Renesas Sensor Control Modules Software Integration System

Introduction

This application note explains the sensor control modules for HS300x and HS400x (Renesas high performance relative humidity and temperature sensor), FS2012, FS3000 and FS1015 (Renesas High Performance Flow Sensor Module), ZMOD4410, ZMOD4450, ZMOD4510 and RRH46410 (Digital Gas Sensors), OB1203 (Heart Rate, Blood Oxygen Concentration, Pulse Oximetry, Proximity, Light and Color Sensor) and I2C communication middleware for Renesas sensors using Software Integration System (SIS).

These control modules acquire the sensor data using the IIC Communication component (IIC Communication (Master mode) component). And calculate relative humidity value [%RH] and temperature value [°C] for HS300x and HS400x, flow value [SLPM (Standard Litter Per Minute) or [SCCM (Standard Cubic Centimeter per Minute)] for FS2012, air velocity value [m/sec] for FS3000 and FS1015, environmental gas value for ZMOD4410, ZMOD4450, ZMOD4510 and RRH46410 and light/proximity/PPG value for OB1203.

Hereinafter, the modules described in this application note is abbreviated as following,

- Sensor Control module for FS1015: FS1015 SIS module (Note 1)
- Sensor Control module for FS2012: FS2012 SIS module (Note 1)
- Sensor Control module for FS3000: FS3000 SIS module (Note 1)
- Sensor Control module for HS300x: HS300x SIS module
- Sensor Control module for HS400x: HS400x SIS module
- Sensor Control module for OB1203: OB1203 SIS module
- Sensor Control module for RRH46410: RRH46410 SIS module (Note 2)
- Sensor Control module for ZMOD4410, ZMOD4450 and ZMOD4510:
ZMOD4XXX SIS module (Note 2)
- I2C Communication Middleware module: COMMS SIS module

Note 1: Each Sensor Control module uses a “rm_fsxxxx_api.h” file. Each module has its own header file.

Therefore, when using the following sensors in user system, please select one of the following:

- FS1015 sensor and FS1015 SIS module
- FS2012 sensor and FS2012 SIS module
- FS3000 sensor and FS3000 SIS module.

For details of header files, refer to “2.5 Header Files”.

Note 2: Each Sensor Control module use a “rm_zmod4xxx_api.h” file. Each module has its own header file.

Therefore, when using the following sensors in user system, please select one of the following:

- ZMOD4410, ZMOD4450 and ZMOD4510 sensors and ZMOD4XXX SIS module
- RRH46410 sensor and RRH46410 SIS module

For details of header files, refer to “2.5 Header Files”.

Target Device

- **Sensors:**

- Renesas Electronics HS300x and HS400x High Performance Relative Humidity and Temperature Sensor (HS300x sensor and HS400x sensor)
- Renesas Electronics FS2012, FS3000 and FS1015 Renesas High Performance Flow Sensor Module (FS2012 sensor, FS3000 sensor and FS1015 sensor)
- Renesas Electronics Digital Gas Sensors ZMOD4410 (ZMOD4410 Indoor Air Quality Platform), ZMOD4450 (ZMOD4450 Refrigeration Air Quality Sensor Platform) and ZMOD4510 (ZMOD4510 Outdoor Air Quality Platform)
- Renesas Electronics RRH46410 Firmware Configurable Air Quality (AQ) Module with Embedded Artificial Intelligence (AI) (RRH46410 sensor module)
- Renesas Electronics Heart Rate, Blood Oxygen Concentration, Pulse Oximetry, Proximity, Light and Color Sensor (OB1203 sensor)

- **RL78 Family MCUs:**

MCUs supported the following IIC Communication (Master mode) component

- Serial Interface IICA
- Simplified I2C using Serial Array Unit (SAU)

When using this application note with other Renesas MCUs, careful evaluation is recommended after making modifications to comply with the alternate MCU.

Target Compiler

- Renesas Electronics C/C++ Compiler Package for RL78 Family

Terminology/Abbreviation**Table 1-1 Terminology/Abbreviation Lists**

Terminology/Abbreviation	Description
ACK	Acknowledge
COMMS SIS Module	Indicates communication driver interface function layer module.
FS1015 Sensor	Indicates FS1015 Air Velocity Sensor Module.
FS1015 SIS Module	Indicates Air Velocity Sensor control module.
FS2012 Sensor	Indicates FS2012 High Performance Flow Sensor Module.
FS2012 SIS Module	Indicates High Performance Flow Sensor control module.
FS3000 Sensor	Indicates FS3000 Air Velocity Sensor Module.
FS3000 SIS Module	Indicates Air Velocity Sensor control module.
HS300x Sensor	Indicates HS300x Relative Humidity and Temperature Sensor.
HS300x SIS Module	Indicates HS300x Relative Humidity and Temperature Sensor control module.
HS400x Sensor	Indicates HS400x Relative Humidity and Temperature Sensor.
HS400x SIS Module	Indicates HS400x Relative Humidity and Temperature Sensor control module.
IIC Communication (Master mode) Component	Indicates IIC Communication (Master mode) Component for Serial Interface IICA or/and Simplified I2C using Serial Array Unit (SAU).
NACK	Not Acknowledge
OB1203 Sensor	Indicates Pulse Oximetry, Proximity, Light and Color Sensor OB1203.
OB1203 SIS Module	Indicates OB1203 Pulse Oximetry, Proximity, Light and Color Sensor control module.
ReST	Repeated Start Condition
RRH46410 Sensor	Indicates RRH46410 Firmware Configurable Air Quality (AQ) Module with Embedded Artificial Intelligence (AI).
RRH46410 SIS Module	Indicates RRH46410 Firmware Configurable Air Quality (AQ) Module with Embedded Artificial Intelligence (AI) control module.
SP	Stop Condition
ST	Start Condition
ZMOD4410 Sensor	Indicates Digital Gas Sensor ZMOD4410 (Indoor Air Quality Platform).
ZMOD4450 Sensor	Indicates Digital Gas Sensor ZMOD4450 (Refrigeration Air Quality Platform).
ZMOD4510 Sensor	Indicates Digital Gas Sensor ZMOD4510 (Outdoor Air Quality Platform).
ZMOD4XXX SIS Module	Indicates ZMOD4410, ZMOD4450 and ZMOD4510 Digital Gas Sensor control module.

Reference Documents

- Renesas Electronics HS300x Datasheet (August 8, 2021) (R36DS0010EU0701)
- Renesas Electronics HS400x Datasheet (June 22,2022) (R36DS0022EU0102)
- Renesas Electronics FS2012 Series Datasheet (August 24, 2018)
- Renesas Electronics FS3000 Series Datasheet (May 31, 2022)
- Renesas Electronics FS1015 Series Datasheet (June 2, 2022)
- Renesas Electronics OB1203 Datasheet (January 12, 2021)
- Renesas Electronics RRH46410 Datasheet (Feb 16, 2024)
- Renesas Electronics ZMOD4410 Datasheet (March 10, 2023)
- Renesas Electronics ZMOD4510 Datasheet (June 30, 2021)
- Renesas Electronics ZMOD4450 Datasheet (June 30, 2021)
- Smart Configurator User's Manual: RL78 API Reference (R20UT4852)
- RL78/G23 User's Manual: The latest version can be downloaded from the Renesas Electronics website.
- Technical Update/Technical News
The latest information can be downloaded from the Renesas Electronics website.
- RL78 Family Compiler CC-RL User's Manual (R20UT3123)
The latest versions can be downloaded from the Renesas Electronics website.

Trademarks

- Pmod™ is a trademark of Digilent Inc.

Contents

1. Overview of Renesas Sensor Control Modules.....	9
1.1 Outline of FS1015 SIS Module.....	10
1.2 Outline of FS2012 SIS Module.....	10
1.3 Outline of FS3000 SIS Module.....	11
1.4 Outline of HS300x SIS Module.....	11
1.5 Outline of HS400x SIS Module.....	11
1.6 Outline of OB1203 SIS Module	12
1.7 Outline of RRH46410 SIS Module.....	12
1.8 Outline of ZMOD4XXX SIS Module.....	13
1.9 Outline of COMMS SIS Module.....	13
1.10 How to Combine Sensor Control Modules and RL78 IIC Components	14
1.11 Operating Test Environment	15
1.12 Notes/Restrictions	15
2. API Information.....	16
2.1 Hardware Requirements	16
2.2 Software Requirements.....	16
2.3 Supported Toolchains	16
2.4 Usage of Interrupt Vector	16
2.5 Header Files	16
2.6 Integer Types.....	16
2.7 Configuration Overview	17
2.7.1 FS1015 SIS Module Configuration (r_fs1015_rl_config.h)	17
2.7.2 FS2012 SIS Module Configuration (r_fs2012_rl_config.h)	18
2.7.3 FS3000 SIS Module Configuration (r_fs3000_rl_config.h)	19
2.7.4 HS300x SIS Module Configuration (r_hs3000_rl_config.h)	20
2.7.5 HS400x SIS Module Configuration (r_hs4000_rl_config.h)	21
2.7.6 OB1203 SIS Module Configuration (r_ob1203_rl_config.h).....	22
2.7.7 RRH46410 SIS Module Configuration (r_rrh46410_rl_config.h).....	27
2.7.8 ZMOD4XXX SIS Module Configuration (r_zmod4xxx_rl_config.h).....	28
2.7.9 COMMS SIS Module Configuration (r_comms_i2c_rl_config.h).....	30
2.8 Code Size	31
2.9 Parameters	32
2.9.1 Configuration Structure and Control Structure of FS1015 SIS Module	32
2.9.2 Configuration Structure and Control Structure of FS2012 SIS Module	33
2.9.3 Configuration Structure and Control Structure of FS3000 SIS Module	34
2.9.4 Configuration Structure and Control Structure of HS300x SIS Module	35
2.9.5 Configuration Structure and Control Structure of HS400x SIS Module	36
2.9.6 Configuration Structure and Control Structure of OB1203 SIS Module	37
2.9.7 Configuration Structure and Control Structure of RRH46410 SIS Module	38

2.9.8	Configuration Structure and Control Structure of ZMOD4xxx SIS Module	39
2.9.9	Configuration Structure and Control Structure of COMMS SIS Module	40
2.10	Return Values	41
2.11	Adding the SIS Module to Your Project	42
3.	FS1015 API Functions	43
3.1	RM_FS1015_Open()	43
3.2	RM_FS1015_Close()	44
3.3	RM_FS1015_Read()	45
3.4	RM_FS1015_DataCalculate()	46
3.5	fs1015_user_callback()	48
3.6	Usage Example of FS1015 Control Module	48
4.	FS2012 API Functions	49
4.1	RM_FS2012_Open()	49
4.2	RM_FS2012_Close()	50
4.3	RM_FS2012_Read()	51
4.4	RM_FS2012_DataCalculate()	52
4.5	fs2012_user_callback()	54
4.6	Usage Example of FS2012 SIS Module	54
5.	FS3000 API Functions	55
5.1	RM_FS3000_Open()	55
5.2	RM_FS3000_Close()	56
5.3	RM_FS3000_Read()	57
5.4	RM_FS3000_DataCalculate()	58
5.5	fs3000_user_callback()	60
5.6	Usage Example of FS3000 SIS Module	60
6.	HS300x API Functions	61
6.1	RM_HS300X_Open()	61
6.2	RM_HS300X_Close()	62
6.3	RM_HS300X_MeasurementStart()	62
6.4	RM_HS300X_Read()	63
6.5	RM_HS300X_DataCalculate()	64
6.6	RM_HS300X_ProgrammingModeEnter()	66
6.7	RM_HS300X_ResolutionChange()	67
6.8	RM_HS300X_SensorIdGet()	69
6.9	RM_HS300X_ProgrammingModeExit()	70
6.10	hs300x_user_callback()	71
6.11	Usage Example of HS300x SIS Module	71
7.	HS400x API Functions	72

7.1	RM_HS400X_Open()	72
7.2	RM_HS400X_Close()	73
7.3	RM_HS400X_MeasurementStart()	74
7.4	RM_HS400X_MeasurementStop()	75
7.5	RM_HS400X_Read()	76
7.6	RM_HS400X_DataCalculate()	77
7.7	hs400x_user_callback()	79
7.8	Usage Example of HS400x SIS Module	79
8.	OB1203 API Functions	80
8.1	RM_OB1203_Open()	80
8.2	RM_OB1203_Close()	81
8.3	RM_OB1203_MeasurementStart()	82
8.4	RM_OB1203_MeasurementStop()	82
8.5	RM_OB1203_LightRead()	83
8.6	RM_OB1203_LightDataCalculate()	84
8.7	RM_OB1203_ProxRead()	85
8.8	RM_OB1203_ProxDDataCalculate()	86
8.9	RM_OB1203_PpgRead()	87
8.10	RM_OB1203_PpgDataCalculate()	88
8.11	RM_OB1203_DeviceStatusGet()	89
8.12	RM_OB1203_DeviceInterruptCfgSet()	90
8.13	RM_OB1203_GainSet()	91
8.14	RM_OB1203_LedCurrentSet()	92
8.15	RM_OB1203_FifoInfoGet()	93
8.16	ob1203_user_xxx_callback()	94
8.17	Usage Example of OB1203 SIS Module	94
9.	RRH46410 API Functions	95
9.1	RM_RRH46410_Open()	95
9.2	RM_RRH46410_Close()	96
9.3	RM_RRH46410_MeasurementStart()	97
9.4	RM_RRH46410_MeasurementStop()	97
9.5	RM_RRH46410_Read()	98
9.6	RM_RRH46410_Iaq2ndGenDataCalculate()	99
9.7	RM_RRH46410_PbaqDataCalculate()	100
9.8	RM_RRH46410_TemperatureAndHumiditySet()	101
9.9	rrh46410_user_xxx_callback()	102
9.10	Usage Example of RRH46410 SIS Module	102
10.	ZMOD4XXX API Functions	103
10.1	RM_ZMOD4XXX_Open()	103

10.2	RM_ZMOD4XXX_Close()	104
10.3	RM_ZMOD4XXX_MeasurementStart()	105
10.4	RM_ZMOD4XXX_MeasurementStop()	105
10.5	RM_ZMOD4XXX_StatusCheck()	106
10.6	RM_ZMOD4XXX_Read()	107
10.7	RM_ZMOD4XXX_Iaq1stGenDataCalculate()	108
10.8	RM_ZMOD4XXX_Iaq2ndGenDataCalculate()	109
10.9	RM_ZMOD4XXX_OdorDataCalculate()	110
10.10	RM_ZMOD4XXX_SulfurOdorDataCalculate()	111
10.11	RM_ZMOD4XXX_Oaq1stGenDataCalculate()	112
10.12	RM_ZMOD4XXX_Oaq2ndGenDataCalculate()	113
10.13	RM_ZMOD4XXX_RaqDataCalculate()	114
10.14	RM_ZMOD4XXX_RellaqDataCalculate()	115
10.15	RM_ZMOD4XXX_PbaqDataCalculate()	116
10.16	RM_ZMOD4XXX_TemperatureAndHumiditySet()	117
10.17	RM_ZMOD4XXX_DeviceErrorCheck()	118
10.18	zmod4xxx_user_xxx_callback()	119
10.19	Usage Example of ZMOD4XXX SIS Module	119
11.	COMMS API Functions	120
11.1	RM_COMMS_I2C_Open()	120
11.2	RM_COMMS_I2C_Close()	121
11.3	RM_COMMS_I2C_Read()	122
11.4	RM_COMMS_I2C_Write()	123
11.5	RM_COMMS_I2C_WriteRead()	124
	Revision History	125
	General Precautions in the Handling of Microprocessing Unit and Microcontroller Unit Products	126
	Notice	127
	Corporate Headquarters	127
	Contact information	127
	Trademarks	127

1. Overview of Renesas Sensor Control Modules

The Renesas sensor control modules described in this application note are a hardware abstraction layer of Renesas sensors. This hardware abstraction layer includes sensor API and communication middleware for various Renesas sensors. The software architecture of Renesas sensor hardware abstraction layer is shown below “Figure 1-1 Renesas Sensor Software Architecture”.

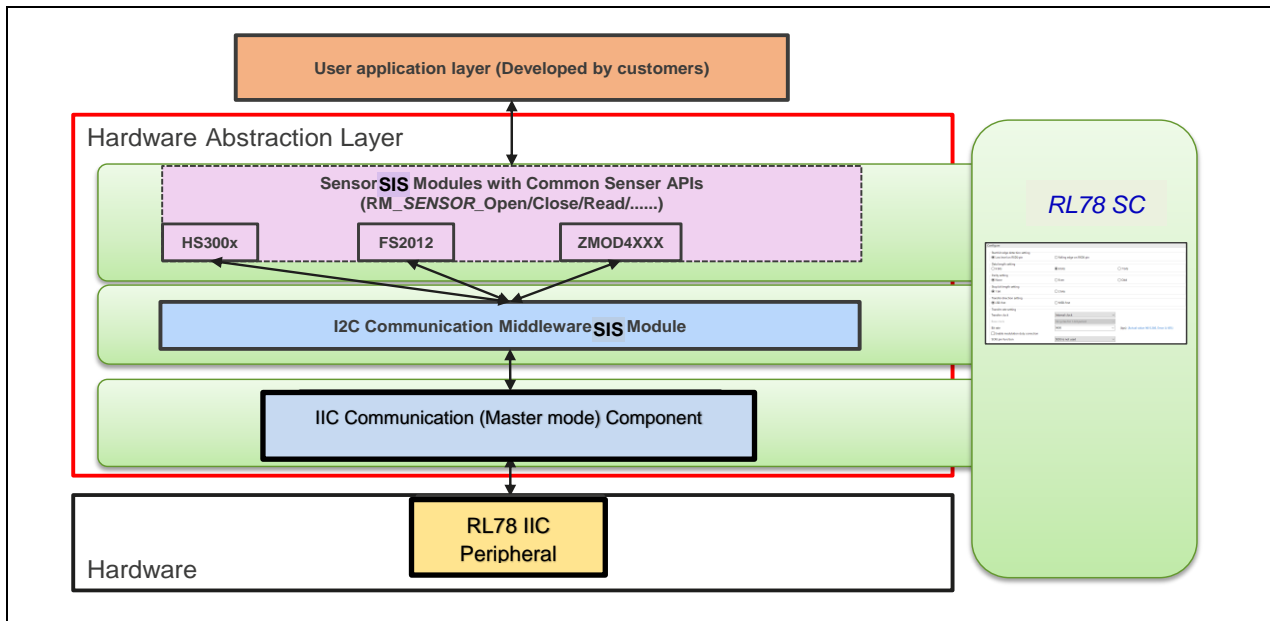

Figure 1-1 Renesas Sensor Software Architecture

The hardware abstraction layer has three layers, “Sensor SIS Modules with Common Sensor APIs”, “I2C Communication Middleware” and “IIC Communication (Master mode) component”.

The sensor APIs of the following Sensor Control modules are provided as “Sensor SIS modules”.

Sensors Type	Sensor SIS Module (Sensor Control Module) Name
FS1015	FS1015 SIS module
FS2012	FS2012 SIS module
FS3000	FS3000 SIS module
HS300x	HS300x SIS module
HS400x	HS400x SIS module
OB1203	OB1203 SIS module
RRH46410	RRH46410 SIS module
ZMOD4410, ZMOD4450, ZMOD4510	ZMOD4XXX SIS module

The I2C Communication Middleware are provided as “COMMS SIS module”.

These Sensor SIS modules provide a method to receive sensor data of each sensor connected to the I2C bus of RL78 family MCUs via “COMMS SIS module”.

Table 1-1 shows the available sensors.

Table 1-2 shows the available IIC SIS modules.

Table 1-1 Available Sensors

Available Sensors	Reference Datasheet
FS1015 Air Velocity Sensor Module	Refer to " Reference Documents "
FS2012 High Performance Flow Sensor Module	
FS3000 Air Velocity Sensor Module	
HS300x High Performance Relative Humidity and Temperature Sensor	
HS400x High Performance Relative Humidity and Temperature Sensor	
OB1203 Heart Rate, Blood Oxygen Concentration, Pulse oximetry, Proximity, Light and Color Sensor	
RRH46410 Firmware Configurable Air Quality (AQ) Module with Embedded Artificial Intelligence (AI)	
ZMOD4410 Digital Gas Sensor (ZMOD4410 Indoor Air Quality Platform)	
ZMOD4450 Digital Gas Sensor (ZMOD4450 Refrigeration Air Quality Sensor Platform)	
ZMOD4510 Digital Gas Sensor (ZMOD4510 Outdoor Air Quality Platform)	

Table 1-2 Available IIC Communication (Master mode) components

Available IIC Communication (Master mode) components	Reference User's Manual
Serial Interface IICA	Smart Configurator User's Manual: RL78 API Reference
Simplified I2C using Serial Array Unit (SAU)	

1.1 Outline of FS1015 SIS Module

The following lists the FS1015 SIS module API functions.

Table 1-3 FS1015 SIS Module API Functions

Function	Description
RM_FS1015_Open()	This function opens and configures the FS1015 SIS module.
RM_FS1015_Close()	This function disables specified FS1015 control block.
RM_FS1015_Read()	This function reads ADC data from FS1015.
RM_FS1015_DataCalculate()	This function calculates air velocity value [m/sec] from ADC data.
fs1015_user_callback()	This is a callback function registered with Smart Configurator by user.

1.2 Outline of FS2012 SIS Module

The following lists the FS2012 SIS module API functions.

Table 1-4 FS2012 SIS Module API Functions

Function	Description
RM_FS2012_Open()	This function opens and configures the FS2012 SIS module.
RM_FS2012_Close()	This function disables specified FS2012 control block.
RM_FS2012_Read()	This function reads ADC data from FS2012.
RM_FS2012_DataCalculate()	This function calculates flow value [SLPM or SCCM] from ADC data.
fs2012_user_callback()	This is a callback function registered with Smart Configurator by user.

1.3 Outline of FS3000 SIS Module

The following lists the FS3000 SIS module API functions.

Table 1-5 FS3000 SIS Module API Functions

Function	Description
RM_FS3000_Open()	This function opens and configures the FS3000 SIS module.
RM_FS3000_Close()	This function disables specified FS3000 control block.
RM_FS3000_Read()	This function reads ADC data from FS3000.
RM_FS3000_DataCalculate()	This function calculates air velocity value [m/sec] from ADC data.
fs3000_user_callback()	This is a callback function registered with Smart Configurator by user.

1.4 Outline of HS300x SIS Module

The following lists the HS300x SIS module API functions.

Table 1-6 HS300x SIS Module API Functions

Function	Description
RM_HS300X_Open()	This function opens and configures the HS300x SIS module.
RM_HS300X_Close()	This function disables specified HS300x control block.
RM_HS300X_MeasurementStart()	This function starts a measurement.
RM_HS300X_Read()	This function reads ADC data from HS300x sensor.
RM_HS300X_DataCalculate()	This function calculates humidity [%RH] and temperature [Celsius] from ADC data.
RM_HS300X_ProgrammingModeEnter()	This function places the HS300x into programming mode.
RM_HS300X_ResolutionChange()	This function changes the HS300x resolution.
RM_HS300X_SensorIdGet()	This function obtains the sensor ID of HS300x.
RM_HS300X_ProgrammingModeExit()	This function exits the HS300x programming mode.
hs300x_user_callback()	This is a callback function registered with Smart Configurator by user.

1.5 Outline of HS400x SIS Module

The following lists the HS400x SIS module API functions.

Table 1-7 HS400x SIS Module API Functions

Function	Description
RM_HS400X_Open()	This function opens and configures the HS400x SIS module.
RM_HS400X_Close()	This function disables specified HS400x control block.
RM_HS400X_MeasurementStart()	This function starts a measurement.
RM_HS400X_MeasurementStop()	This function stops a periodic measurement.
RM_HS400X_Read()	This function reads ADC data from HS400x sensor.
RM_HS400X_DataCalculate()	This function calculates humidity [%RH] and temperature [Celsius] from ADC data.
hs400x_user_callback()	This is a callback function registered with Smart Configurator by user.

1.6 Outline of OB1203 SIS Module

The following lists the OB1203 SIS module API functions.

Table 1-8 OB1203 SIS module API Functions

Function	Description
RM_OB1203_Open()	This function opens and configures the ZMOD4XXX SIS module.
RM_OB1203_Close()	This function disables specified ZMOD4XXX control block.
RM_OB1203_MeasurementStart()	This function starts a measurement.
RM_OB1203_MeasurementStop()	This function stops a measurement.
RM_OB1203_LightRead()	This function reads Light ADC data from OB1203 device.
RM_OB1203_LightDataCalculate()	This function calculates light data from raw data.
RM_OB1203_ProxRead()	This function reads Proximity ADC data from OB1203 device.
RM_OB1203_ProxDDataCalculate()	This function calculates proximity data from raw data.
RM_OB1203_PpgRead()	This function reads PPG ADC data from OB1203 device.
RM_OB1203_PpgDataCalculate()	This function calculates PPG data from raw data.
RM_OB1203_DeviceStatusGet()	This function gets device status from OB1203 device.
RM_OB1203_DeviceInterruptCfgSet()	This function sets device interrupt configurations.
RM_OB1203_GainSet()	This function sets gain.
RM_OB1203_LedCurrentSet()	This function sets led currents.
RM_OB1203_FifoInfoGet()	This function gets FIFO information from OB1203 device.
ob1203_user_xxx_callback()	This is a callback function registered with Smart Configurator by user.

1.7 Outline of RRH46410 SIS Module

The following lists the RRH46410 SIS module API functions.

Table 1-9 RRH46410 SIS Module API Functions

Function	Description
RM_RRH46410_Open()	This function opens and configures the RRH46410 SIS module.
RM_RRH46410_Close()	This function disables specified RRH46410 control block.
RM_RRH46410_MeasurementStart()	This function starts a measurement.
RM_RRH46410_MeasurementStop()	This function stops a measurement.
RM_RRH46410_Read()	This function reads measurement data from RRH46410.
RM_RRH46410_Iaq2ndGenDataCalculate()	This function calculates IAQ (Indoor Air Quality) 2 nd Gen values from measurement data.
RM_RRH46410_PbaqDataCalculate()	This function calculates PBAQ values from measurement data.
RM_RRH46410_TemperatureAndHumiditySet()	This function sets humidity to RRH46410 sensor. Temperature is unsupported.
rrh46410_user_xxx_callback()	This is a callback function registered with Smart Configurator by user.

1.8 Outline of ZMOD4XXX SIS Module

The following lists the ZMOD4XXX SIS module API functions.

Table 1-10 ZMOD4XXX SIS Module API Functions

Function	Description
RM_ZMOD4XXX_Open()	This function opens and configures the ZMOD4XXX SIS module.
RM_ZMOD4XXX_Close()	This function disables specified ZMOD4XXX control block.
RM_ZMOD4XXX_MeasurementStart()	This function starts a measurement.
RM_ZMOD4XXX_MeasurementStop()	This function stops a measurement.
RM_ZMOD4XXX_StatusCheck()	This function read status of ZMOD4410 or ZMOD4510 sensor.
RM_ZMOD4XXX_Read()	This function reads ADC data from ZMOD4410 or ZMOD4510 sensor.
RM_ZMOD4XXX_iaq1stGenDataCalculate()	This function calculates IAQ (Indoor Air Quality) 1 st Gen. values from ADC data.
RM_ZMOD4XXX_iaq2ndGenDataCalculate()	This function calculates IAQ (Indoor Air Quality) 2 nd Gen. values from ADC data.
RM_ZMOD4XXX_OdorDataCalculate()	This function calculates Odor values from ADC data.
RM_ZMOD4XXX_SulfurOdorDataCalculate()	This function calculates Sulfur Odor values from ADC data.
RM_ZMOD4XXX_Oaq1stGenDataCalculate()	This function calculates OAQ 1 st Gen. values from ADC data.
RM_ZMOD4XXX_Oaq2ndGenDataCalculate()	This function calculates OAQ 2 nd Gen. values from ADC data.
RM_ZMOD4XXX_RaqDataCalculate()	This function calculates RAQ values from ADC data.
RM_ZMOD4XXX_RellaqDataCalculate()	This function calculates Rel IAQ (Indoor Air Quality) values from ADC data.
RM_ZMOD4XXX_PbaqDataCalculate()	This function calculates PBAQ values from ADC data.
RM_ZMOD4XXX_TemperatureAndHumiditySet()	This function sets temperature and humidity to ZMOD4410 or ZMOD4510 sensor.
RM_ZMOD4XXX_DeviceErrorCheck()	This function checks for device errors such as unexpected resets
zmod4xxx_user_xxx_callback()	This is a callback function registered with Smart Configurator by user.

1.9 Outline of COMMS SIS Module

Table 1-11 Senser communication middleware SIS module API Functions lists the COMMS SIS functions.

Table 1-11 Senser communication middleware SIS module API Functions

Function	Description
RM_COMMS_I2C_Open()	The function opens and configures the COMMS SIS module.
RM_COMMS_I2C_Close()	This function disables specified COMMS SIS module.
RM_COMMS_I2C_Read()	The function performs a read from I2C device.
RM_COMMS_I2C_Write()	The function performs a write from the I2C device.
RM_COMMS_I2C_WriteRead()	The function performs a write to, then a read from the I2C device.

1.10 How to Combine Sensor Control Modules and RL78 IIC Components

Sensor SIS module and COMMS SIS module can control simultaneously multiple sensors on any channel of any I2C bus.

However, the sensors using same slave address cannot be connected to a same channel of I2C bus.

Figure 1-2 shows the relationship of Sensor SIS modules and COMMS SIS module, IIC Communication (Master mode) components and the I2C devices.

The COMMS SIS module is a driver interface function layer to absorb the difference between the Sensor SIS modules and RL78 IIC components.

The initialization processing of these SIS modules opens the module and sets control structure values according to configurations set by user. The initialization of I2C bus is done automatically in system initialize sequence (R_Systeminit), so there is no need to initialize it in the user application.

For the configuration related to these SIS module, refer to "2.7 Configuration Overview"

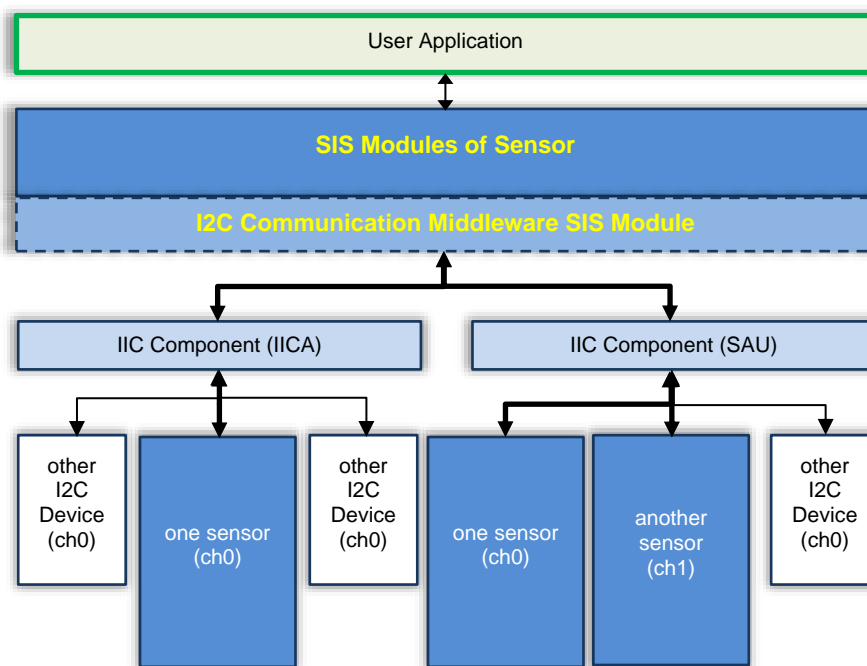

Since each I2C bus/channel is configured for each sensor, multiple sensors can be controlled simultaneously.

The IIC component can be controlled simultaneously.

However, since only a slave address is used for each sensor, only one sensor can be controlled on a same channel of the I2C bus.

Figure 1-2 Example of Combination of Sensor SIS Modules and IIC Components

1.11 Operating Test Environment

This section describes for detailed the operating test environments of these SIS modules.

Table 1-12 Operation Test Environment

Item	Contents
Integrated Development Environment	Renesas Electronics e2 studio 2024-04
C Compiler	Renesas Electronics C/C++ compiler for RL78 family V1.13.00 Compiler options: The integrated development environment default settings are used, with the following option added. -lang = c99
Endian Order	Little-endian
Component Version	IIC Communication (Master mode) Ver.1.5.1
Sensor Board Used	Vertical Mount Air Velocity Sensor Pmod Board (US082-FS1015EVZ) Gas Mass Flow Sensor Pmod Board (US082-FS2012EVZ) Air Velocity Sensor Pmod Board (US082-FS3000EVZ) Relative Humidity Sensor Pmod Board (US082-HS3001EVZ) Relative Humidity Sensor Pmod Board (QCIOT-HS4001POCZ) Pulse Oximetry, Proximity, Light, and Color Sensor Pmod Board (US082-OB1203EVZ) RRH46410 Sensor Pmod Board TVOC and Indoor Air Quality Sensor Pmod Board (US082-ZMOD4410EVZ) Refrigeration Air Quality Sensor Pmod Board (US082-ZMOD4450EVZ) Outdoor Air Quality Sensor Pmod Board (US082-ZMOD4510EVZ) Interposer Board for Pmod Type2/3 to 6A (US082-INTERPEVZ)

1.12 Notes/Restrictions

- The operation by single master control has been confirmed. The operation by multi-master control is unconfirmed. When using it in multi-master control, evaluate it sufficiently.
- Operation has been confirmed only when the data endian is little endian.
- For the notes and restrictions of the IIC Communication (Master mode) component, refer to Smart Configurator User's Manual: RL78 API Reference.
- For maximum numbers of RRH46410 sensors, only one sensor can be configured in the user system. Refer to "2.7.7 RRH46410 SIS Module Configuration (r_rrh46410_rl_config.h)".

2. API Information

2.1 Hardware Requirements

The MCU used must support one or both of the following functions.

- Serial Interface IICA
- Serial Array Unit (SAU): Simplified I2C mode

2.2 Software Requirements

The SIS modules are dependent upon the following packages:

- Board Support Package Module (r_bsp) Ver.1.41 or higher
- IIC Communication (Master mode) Component Ver.1.11 or higher

2.3 Supported Toolchains

The SIS modules are tested and work with the following toolchain:

- Renesas RL78 Toolchain v.1.10.00 or higher

2.4 Usage of Interrupt Vector

The SIS modules do not use interrupts. However, the IIC Communication (Master mode) component to be used use interrupts. Refer to Smart Configurator User's Manual: RL78 API Reference for detail information.

2.5 Header Files

All API calls and their supporting interface definitions are located as following.

Sensor SIS Module	Header Files		
FS1015 SIS Module	r_fs1015_if.h	rm_fsxxxx_api.h (Note 1)	rm_fs1015.h
FS2012 SIS Module	r_fs2012_if.h		rm_fs2012.h
FS3000 SIS Module	r_fs3000_if.h		rm_fs3000.h
HS300x SIS Module	r_hs300x_if.h	rm_hs300x_api.h	rm_hs300x.h
HS400x SIS Module	r_hs400x_if.h	rm_hs400x_api.h	rm_hs400x.h
OB1203 SIS Module	r_ob1203_if.h	rm_ob1203_api.h	rm_ob1203.h
RRH46410 SIS Module	r_rrh46410_if.h	rm_zmod4xxx_api.h (Note 2)	rm_rrh46410.h
ZMOD4XXX SIS Module	r_zmod4xxx_if.h	rm_zmod4xxx_api.h (Note 2]	rm_zmod4xxx.h
COMMS SIS Module	r_comms_i2c_if.h	rm_comms_api.h	rm_comms_i2c.h

Note 1: Although the file names are the same, the versions may differ due to revisions.

However, the header files are **identical** on Aug 26, 2024, it is possible to include different modules at the same time.

Note 2: Although the file names are the same, the versions may differ due to revisions.

The header files are **not identical** on Aug 26, 2024.

2.6 Integer Types

The projects for these SIS modules use ANSI C99. These types are defined instdint.h.

2.7 Configuration Overview

The configuration options in these SIS modules are specified in

r_fs1015_rl_config.h and rm_fs1015_instance.c for FS1015 SIS module,
 r_fs2012_rl_config.h and rm_fs2012_instance.c for FS2012 SIS module,
 r_fs3000_rl_config.h and rm_fs3000_instance.c for FS3000 SIS module,
 r_hs300x_rl_config.h and rm_hs300x_instance.c for HS300x SIS module,
 r_hs400x_rl_config.h and rm_hs400x_instance.c for HS400x SIS module,
 r_ob1203_rl_config.h and rm_ob1203_instance.c for OB1203 SIS module,
 r_rrh46410_rx_config.h and rm_rrh46410_instance.c for RRH46410 SIS module,
 r_zmod4xxx_rl_config.h and rm_zmod4xxx_instance.c for ZMOD4XXX SIS module,
 r_comms_i2c_rl_config.h and rm_comms_i2c_rl_instance.c.

It is also necessary to set the IIC Communication (Master mode) component to be used. Refer to Smart Configurator User's Manual: RL78 API Reference for detail information.

2.7.1 FS1015 SIS Module Configuration (r_fs1015_rl_config.h)

The following explains the option names and setting values of this SIS module. The configuration settings shown in following table are set on Smart Configurator.

Configuration Options	Description (Smart Configurator Display)
RM_FS1015_CFG_PARAM_CHECKING_ENABLE	Specify whether to include code for API parameter checking. Selection: BSP Enabled Disabled Default: BSP
RM_FS1015_CFG_DEVICE_NUM_MAX	Specify maximum numbers of FS1015 sensors. Selection: 1 - 2 Default: 1
RM_FS1015_CFG_DEVICE_TYPE	Specify device type of FS1015 Sensor. (Note 2) Selection: FS1015-1005 Default: FS1015-1005
RM_FS1015_CFG_DEVICE(x)_COMMS_INSTANCE (“x” = 0-1)	Specify using communication line instance. (Note 1) Selection: I2C Communication Device(y) (y: 0 - 4) Default: I2C Communication Device(x) (When Device0 is selected, set “g_comms_i2c_device0”)
RM_FS1015_CFG_DEVICE(x)_CALLBACK (“x” = 0-1)	Specify user callback function name. Selection: None (Need user to input) Default: fs1015_user_callback(x)

Note 1: Do not set same “I2C Communication Device(y)” number for sensor device 0 and sensor device 1. The “y” = 0-4.

Note 2: FS1015-1005 is a 0 to 7.23 m/sec air velocity range device, FS1015-1015 is a 0 to 15 m/sec air velocity range device. Refer to FS1015 datasheet for detail information. This control module only supports FS1015-1005 currently.

2.7.2 FS2012 SIS Module Configuration (r_fs2012_rl_config.h)

The following explains the option names and setting values of this SIS module. The configuration settings shown in following table are set on Smart Configurator.

Configuration Options	Description (Smart Configurator Display)
RM_FS2012_CFG_PARAM_CHECKING_ENABLE	Specify whether to include code for API parameter checking. Selection: BSP Enabled Disabled Default: BSP
RM_FS2012_CFG_DEVICE_NUM_MAX	Specify maximum numbers of FS2012 sensors. Selection: 1 - 2 Default: 1
RM_FS2012_CFG_DEVICE_TYPE	Specify device type of FS2012 Sensor. (Note 2) Selection: FS2012-1020-NG FS2012-1100-NG Default: FS2012-1020-NG
RM_FS2012_CFG_DEVICE(x)_COMMS_INSTANCE (“x” = 0-1)	Specify using communication line instance. (Note 1) Selection: I2C Communication Device(y) (y: 0 - 4) Default: I2C Communication Device(x) (When Device0 is selected, set “g_comms_i2c_device0”)
RM_FS2012_CFG_DEVICE(x)_CALLBACK (“x” = 0-1)	Specify user callback function name. Selection: None (Need user to input) Default: fs2012_user_callback(x)

Note 1: Do not set same “I2C Communication Device(y)” number for sensor device 0 and sensor device 1. The “y” = 0-4.

Note 2: FS2012-1020-NG is 0 to 2 SLPM (Standard Liter Per Minute) calibrated gas flow sensor mounted on a circuit board with a flow housing, FS2012-1100-NG is 0 to 10 SLPM (Standard Liter Per Minute) calibrated gas flow sensor mounted on a circuit board with a flow housing. This SIS module only supports FS2012-1020-NG and FS2012-1100-NG currently.

2.7.3 FS3000 SIS Module Configuration (r_fs3000_rl_config.h)

The following explains the option names and setting values of this SIS module. The configuration settings shown in following table are set on Smart Configurator.

Configuration Options	Description (Smart Configurator Display)
RM_FS3000_CFG_PARAM_CHECKING_ENABLE	Specify whether to include code for API parameter checking. Selection: BSP Enabled Disabled Default: BSP
RM_FS3000_CFG_DEVICE_NUM_MAX	Specify maximum numbers of FS3000 sensors. Selection: 1 - 2 Default: 1
RM_FS3000_CFG_DEVICE_TYPE	Specify device type of FS3000 Sensor. (Note 2) Selection: FS3000-1005 Default: FS3000-1005
RM_FS3000_CFG_DEVICE(x)_COMMS_INSTANCE (“x” = 0-1)	Specify using communication line instance. (Note 1) Selection: I2C Communication Device(y) (y: 0 - 4) Default: I2C Communication Device(x) (When Device0 is selected, set “g_comms_i2c_device0”)
RM_FS3000_CFG_DEVICE(x)_CALLBACK (“x” = 0-1)	Specify user callback function name. Selection: None (Need user to input) Default: fs3000_user_callback(x)

Note 1: Do not set same “I2C Communication Device(y)” number for sensor device 0 and sensor device 1. The “y” = 0-4.

Note 2: FS3000-1005 is a 0 to 7.23 m/sec air velocity range device, FS3000-1015 is a 0 to 15 m/sec air velocity range device. Refer to FS3000 datasheet for detail information. This control module only supports FS3000-1005 currently.

2.7.4 HS300x SIS Module Configuration (r_hs3000_rl_config.h)

The following explains the option names and setting values of this SIS module. The configuration settings shown in following table are set on Smart Configurator.

Configuration Options	Description (Smart Configurator Display)
RM_HS300X_CFG_PARAM_CHECKING_ENABLE	Specify whether to include code for API parameter checking. Selection: BSP Enabled Disabled Default: BSP
RM_HS300X_CFG_DEVICE_NUM_MAX	Specify maximum numbers of HS300x sensors. Selection: 1 - 2 Default: 1
RM_HS300X_CFG_DATA_BOTH_HUMIDITY_TEMPERATURE	Specify HS300x sensor data type. Selection: Humidity only Both humidity and temperature Default: Both humidity and temperature
RM_HS300X_CFG_PROGRAMMING_MODE	Specify programming mode on or off. Selection: Disabled (0) Enabled (1) Default: Disabled (0)
RM_HS300X_CFG_DEVICE(x)_COMMS_INSTANCE ("x" = 0-1)	Specify using communication line instance. (Note 1) Selection: I2C Communication Device(y) (y: 0 - 4) Default: I2C Communication Device(x) (When Device0 is selected, set "g_comms_i2c_device0")
RM_HS300X_CFG_DEVICE(x)_CALLBACK ("x" = 0-1)	Specify user callback function name. Selection: None (Need user to input.) Default: hs300x_user_callback(x)

Note 1: Do not set same "I2C Communication Device(y)" number for sensor device 0 and sensor device 1.
The "y" = 0-4.

2.7.5 HS400x SIS Module Configuration (r_hs4000_rl_config.h)

The following explains the option names and setting values of this SIS module. The configuration settings shown in following table are set on Smart Configurator.

Configuration Options	Description (Smart Configurator Display)
RM_HS400X_CFG_PARAM_CHECKING_ENABLE	Specify whether to include code for API parameter checking. Selection: BSP Enabled Disabled Default: BSP
RM_HS400X_CFG_DEVICE_NUM_MAX	Specify maximum numbers of HS400x sensors. Selection: 1 - 2 Default: 1
RM_HS400X_CFG_MEASUREMENT_TYPE	Specify HS400x sensor measurement type. Selection: Hold Measurement No-Hold Measurement Periodic Measurement Default: No-Hold Measurement
RM_HS400X_CFG_DATA_BOTH_HUMIDITY_TEMPERATURE	Specify HS400x sensor data type. Selection: Temperature only Both humidity and temperature Default: Both humidity and temperature
RM_HS400X_CFG_DEVICE(x)_COMMS_INSTANCE (“x” = 0-1)	Specify using communication line instance. (Note 1) Selection: I2C Communication Device(y) (y: 0 - 4) Default: I2C Communication Device(x) (When Device0 is selected, set “g_comms_i2c_device0”)
RM_HS400X_CFG_DEVICE(x)_TEMPERATURE_RESOLUTION (“x” = 0-1)	Specify HS400x sensor temperature resolution. Selection: 8-bit 10-bit 12-bit 14-bit Default: 14-bit
RM_HS400X_CFG_DEVICE(x)_HUMIDITY_RESOLUTION (“x” = 0-1)	Specify HS400x sensor humidity resolution. Selection: 8-bit 10-bit 12-bit 14-bit Default: 14-bit
RM_HS400X_CFG_DEVICE(x)_PERIODIC_MEASUREMENT_FREQUENCY (“x” = 0-1)	Specify HS400x sensor frequency for periodic measurement. Selection: 0.4Hz 1Hz 2Hz Default: 1Hz
RM_HS400X_CFG_DEVICE(x)_CALLBACK (“x” = 0-1)	Specify user callback function name. Selection: None (Need user to input.) Default: hs400x_user_i2c_callback(x)

Note 1: Do not set same “I2C Communication Device(y)” number for sensor device 0 and sensor device 1.
The “y” = 0-4.

2.7.6 OB1203 SIS Module Configuration (r_ob1203_rl_config.h)

The following explains the option names and setting values of this SIS module. The configuration settings shown in following table are set on Smart Configurator.

Configuration Options	Description (Smart Configurator Display)
RM_OB1203_CFG_PARAM_CHECKING_ENABLE	Specify whether to include code for API parameter checking. Selection: BSP Enabled Disabled Default: BSP
RM_OB1203_CFG_DEVICE_NUM_MAX	Specify maximum numbers of OB1203 sensors. Selection: 1 - 2 Default: 1
RM_OB1203_CFG_DEVICE(x)_COMMS_INSTANCE ("x" = 0-1)	Specify using communication line instance. (Note 1) Selection: I2C Communication Device(y) (y: 0 - 4) Default: I2C Communication Device(x) (When Device0 is selected, set "g_comms_i2c_device0")
RM_OB1203_CFG_DEVICE(x)_COMMS_I2C_CALLBACK ("x" = 0-1)	Specify user I2C callback function name. Selection: None (Need user to input.) Default: ob1203_user_i2c_callback(x)
RM_OB1203_CFG_DEVICE(x)_IRQ_ENABLE ("x" = 0-1)	Enable INTC. Selection: Enabled Disabled Default: Disabled
RM_OB1203_CFG_DEVICE(x)_IRQ_CALLBACK ("x" = 0-1)	Specify user INTC callback function name. Selection: None Default: ob1203_user_irq_callback(x) (Need user to input.)
RM_OB1203_CFG_DEVICE(x)_IRQ_NUMBER ("x" = 0-1)	Specify INTC number. Selection: INTP0 - INTP15 Default: INTP0
RM_OB1203_CFG_DEVICE(x)_SENSOR_MODE ("x" = 0-1)	Specify the sensor mode. Selection: Not selected Light Sensor mode Proximity Sensor mode Light Proximity Sensor mode PPG Sensor mode Default: Not selected
RM_OB1203_CFG_DEVICE(x)_LIGHT_PROX_DEVICE_INTERRUPT ("x" = 0-1)	Specify the operation mode using device interrupt for Light Proximity mode. Selection: Light mode interrupt Proximity mode interrupt Default: Light mode interrupt
RM_OB1203_CFG_DEVICE(x)_PPG_PROX_GAIN ("x" = 0-1)	Specify the gain for Proximity and PPG modes. Selection: 1 1.5 2 4 Default: 1
RM_OB1203_CFG_DEVICE(x)_LED_ORDER ("x" = 0-1)	Specify the LED order for Proximity and PPG mode. Selection: IR LED first, Red LED second Red LED first, IR LED second Default: IR LED first, Red LED second
RM_OB1203_CFG_DEVICE(x)_LIGHT_SENSOR_MODE ("x" = 0-1)	Specify the sensor mode for Light mode. Selection: LS mode CS mode Default: LS mode
RM_OB1203_CFG_DEVICE(x)_LIGHT_INTERRUPT_TYPE ("x" = 0-1)	Specify the interrupt type for Light mode. Selection: Threshold Variation Default: Threshold
RM_OB1203_CFG_DEVICE(x)_LIGHT_INTERRUPT_SOURCE ("x" = 0-1)	Specify the interrupt source for Light mode. Selection: Clear channel Green channel Red channel (CS mode only)

	Blue channel (CS mode only) Default: Clear channel
RM_OB1203_CFG_DEVICE(x) _LIGHT_INTERRUPT_PERSIST T ("x" = 0-1)	Specify the number of similar consecutive interrupt events that must occur before the interrupt is asserted (4bits) for Light mode. Min = 0x0 and Max = 0xF Selection: None (Need user to input) Default: 0x02
RM_OB1203_CFG_DEVICE(x) _LIGHT_SLEEP_AFTER_INTERRUPT R ("x" = 0-1)	Enable the sleep after interrupt for Light mode. Selection: Disabled Enabled Default: Disabled
RM_OB1203_CFG_DEVICE(x) _LIGHT_GAIN ("x" = 0-1)	Specify the gain for Light mode. Selection: 1 3 6 Default: 1
RM_OB1203_CFG_DEVICE(x) _LIGHT_UPPER_THRESHOLD ("x" = 0-1)	Specify the upper threshold value (20bits) for Light mode. Min = 0x00000 and Max = 0xFFFFF. Selection: None (Need user to input) Default: 0x00CCC
RM_OB1203_CFG_DEVICE(x) _LIGHT_LOWER_THRESHOLD ("x" = 0-1)	Specify the lower threshold value (20bits) for Light mode. Min = 0x00000 and Max = 0xFFFFF. Selection: None (Need user to input) Default: 0x00000
RM_OB1203_CFG_DEVICE(x) _LIGHT_VARIANCE_THRESHOLD LD ("x" = 0-1)	Specify variance threshold for Light mode. Selection: +/- 8 counts +/- 16 counts +/- 32 counts +/- 64 counts +/- 128 counts +/- 256 counts +/- 512 counts +/- 1024 counts Default: +/- 128 counts

<p>RM_OB1203_CFG_DEVICE(x) _LIGHT_RESOLUTION_PERIOD ("x" = 0-1)</p>	<p>Specify resolution and measurement period for Light mode. Selection: Resolution:13 bits. Measurement Period:25ms Resolution:13 bits. Measurement Period:50ms Resolution:13 bits. Measurement Period:100ms Resolution:13 bits. Measurement Period:200ms Resolution:13 bits. Measurement Period:500ms Resolution:13 bits. Measurement Period:1000ms Resolution:13 bits. Measurement Period:2000ms Resolution:16 bits. Measurement Period:25ms Resolution:16 bits. Measurement Period:50ms Resolution:16 bits. Measurement Period:100ms Resolution:16 bits. Measurement Period:200ms Resolution:16 bits. Measurement Period:500ms Resolution:16 bits. Measurement Period:1000ms Resolution:16 bits. Measurement Period:2000ms Resolution:17 bits. Measurement Period:50ms Resolution:17 bits. Measurement Period:100ms Resolution:17 bits. Measurement Period:200ms Resolution:17 bits. Measurement Period:500ms Resolution:17 bits. Measurement Period:1000ms Resolution:17 bits. Measurement Period:2000ms Resolution:18 bits. Measurement Period:100ms Resolution:18 bits. Measurement Period:200ms Resolution:18 bits. Measurement Period:500ms Resolution:18 bits. Measurement Period:1000ms Resolution:18 bits. Measurement Period:2000ms Resolution:19 bits. Measurement Period:200ms Resolution:19 bits. Measurement Period:500ms Resolution:19 bits. Measurement Period:1000ms Resolution:19 bits. Measurement Period:2000ms Resolution:20 bits. Measurement Period:500ms Resolution:20 bits. Measurement Period:1000ms Resolution:20 bits. Measurement Period:2000ms Default: Resolution:18 bits. Measurement Period:100ms</p>
<p>RM_OB1203_CFG_DEVICE(x) _PROX_INTERRUPT_TYPE ("x" = 0-1)</p>	<p>Specify the interrupt type for Proximity mode. Selection: Normal Logic Default: Normal</p>
<p>RM_OB1203_CFG_DEVICE(x) _PROX_INTERRUPT_PERSIST ("x" = 0-1)</p>	<p>Specify the number of similar consecutive interrupt events that must occur before the interrupt is asserted (4bits) for Proximity mode. Min = 0x0 and Max = 0xF Selection: None (Need user to input) Default: 0x02</p>
<p>RM_OB1203_CFG_DEVICE(x) _PROX_SLEEP_AFTER_INTERRUPT ("x" = 0-1)</p>	<p>Specify the sleep after interrupt of OB1203 sensor device. Selection: Disabled Enabled Default: Disabled</p>
<p>RM_OB1203_CFG_DEVICE(x) _PROX_LED_CURRENT ("x" = 0-1)</p>	<p>Specify the current of LED (10bits) for Proximity mode. Min = 0x000 and Max = 0x3FF Selection: None (Need user to input.) Default: 0x100</p>
<p>RM_OB1203_CFG_DEVICE(x) _PROX_ANA_CAN ("x" = 0-1)</p>	<p>Enable the LED analog cancellation for Proximity mode. Selection: Disabled Enabled (50% offset of the full-scale value) Default: Disabled</p>
<p>RM_OB1203_CFG_DEVICE(x) _PROX_DIG_CAN ("x" = 0-1)</p>	<p>Specify the LED digital cancellation (16bits) of Proximity mode. Min = 0x0000 and Max = 0xFFFF Selection: None (Need user to input.) Default: 0x100</p>

RM_OB1203_CFG_DEVICE(x) _PROX_NUM_LED_PULSES ("x" = 0-1)	Specify the number of LED pulses for Proximity mode. Selection: 1 pulse 2 pulses 4 pulses 8 pulses 16 pulses 32 pulses Default: 8 pulses
RM_OB1203_CFG_DEVICE(x) _PROX_UPPER_THRESHOLD ("x" = 0-1)	Specify the upper threshold value (16bits) for Proximity mode. Min = 0x0000 and Max = 0xFFFF Selection: None (Need user to input) Default: 0x00600
RM_OB1203_CFG_DEVICE(x) _PROX_LOWER_THRESHOLD ("x" = 0-1)	Specify the lower threshold value (16bits) for Proximity mode. Min = 0x0000 and Max = 0xFFFF Selection: None (Need user to input) Default: 0x00000
RM_OB1203_CFG_DEVICE(x) _PROX_WIDTH_PERIOD ("x" = 0-1)	Specify the pulse width and measurement period for Proximity mode. Selection: Pulse width:26us. Measurement Period:3.125ms. (Expect for the number 32 of LED pulses) Pulse width:26us. Measurement Period:6.25ms. Pulse width:26us. Measurement Period:12.5ms Pulse width:26us. Measurement Period:25ms Pulse width:26us. Measurement Period:50ms Pulse width:26us. Measurement Period:100ms Pulse width:26us. Measurement Period:200ms Pulse width:26us. Measurement Period:400ms Pulse width:42us. Measurement Period:3.125ms. (Expect for the number 32 of LED pulses) Pulse width:42us. Measurement Period:6.25ms Pulse width:42us. Measurement Period:12.5ms Pulse width:42us. Measurement Period:25ms Pulse width:42us. Measurement Period:50ms Pulse width:42us. Measurement Period:100ms Pulse width:42us. Measurement Period:200ms Pulse width:42us. Measurement Period:400ms Pulse width:71us. Measurement Period:3.125ms. (Except for the number 16 and 32 of LED pulses) Pulse width:71us. Measurement Period:6.25ms. (Expect for the number 32 of LED pulses) Pulse width:71us. Measurement Period:12.5ms Pulse width:71us. Measurement Period:25ms Pulse width:71us. Measurement Period:50ms Pulse width:71us. Measurement Period:100ms Pulse width:71us. Measurement Period:200ms Pulse width:71us. Measurement Period:400ms Default: Pulse width:42us. Measurement Period:100ms
RM_OB1203_CFG_DEVICE(x) _PROX_MOVING_AVERAGE ("x" = 0-1)	Enable the moving average for Proximity mode. Selection: Disabled Enabled Default: Disabled
RM_OB1203_CFG_DEVICE(x) _PROX_HYSTERESIS ("x" = 0-1)	Specify the hysteresis value (7bits) for Proximity mode. Min = 0x00 and Max = 0x7F. Selection: None (Need user to input) Default: 0x00
RM_OB1203_CFG_DEVICE(x) _PPG_SENSOR_MODE ("x" = 0-1)	Specify the sensor mode for PPG mode. Selection: PPG1 mode PPG2 mode Default: PPG2 mode
RM_OB1203_CFG_DEVICE(x) _PPG_INTERRUPT_TYPE ("x" = 0-1)	Specify the interrupt type for PPG mode. Selection: Data FIFO Almost Full Default: Data
RM_OB1203_CFG_DEVICE(x) _PPG_IR_LED_CURRENT ("x" = 0-1)	Specify the current of IR LED (10bits) for PPG mode. Min = 0x000 and Max = 0x3FF Selection: None (Need user to input) Default: 0x366

RM_OB1203_CFG_DEVICE(x) _PPG_RED_LED_CURRENT ("x" = 0-1)	Specify the current of Red LED (9bits) for PPG mode. Min = 0x000 and Max = 0x1FF Selection: None (Need user to input) Default: 0x1B3
RM_OB1203_CFG_DEVICE(x) _PPG_POWER_SAVE_MODE ("x" = 0-1)	Enable the power save mode for PPG mode. Selection: Disabled Enabled Default: Disabled
RM_OB1203_CFG_DEVICE(x) _PPG_IR_LED_ANA_CAN ("x" = 0-1)	Enable the IR LED analog cancellation for PPG mode. Selection: Disabled Enabled (50% offset of the full-scale value) Default: Disabled
RM_OB1203_CFG_DEVICE(x) _PPG_RED_LED_ANA_CAN ("x" = 0-1)	Enable the Red LED analog cancellation for PPG mode. Selection: Disabled Enabled (50% offset of the full-scale value) Default: Disabled
RM_OB1203_CFG_DEVICE(x) _PPG_NUM_AVERAGED_SAMPLES ("x" = 0-1)	Specify the number of averaged PPG samples for PPG mode. Selection: 1 (No averaging) 2 consecutives samples are averaged 4 consecutives samples are averaged 8 consecutives samples are averaged 16 consecutives samples are averaged 32 consecutives samples are averaged Default: 8 consecutives samples are averaged
RM_OB1203_CFG_DEVICE(x) _PPG_WIDTH_PERIOD ("x" = 0-1)	Specify the pulse width and measurement period for PPG mode Selection: Pulse width:130us. Measurement Period:0.3125ms. (PPG1 mode only) Pulse width:130us. Measurement Period:0.625ms Pulse width:130us. Measurement Period:1ms Pulse width:130us. Measurement Period:1.25ms Pulse width:130us. Measurement Period:2.5ms Pulse width:130us. Measurement Period:5ms Pulse width:130us. Measurement Period:10ms Pulse width:130us. Measurement Period:20ms Pulse width:247us. Measurement Period:0.625ms. (PPG1 mode only) Pulse width:247us. Measurement Period:1ms Pulse width:247us. Measurement Period:1.25ms Pulse width:247us. Measurement Period:2.5ms Pulse width:247us. Measurement Period:5ms Pulse width:247us. Measurement Period:10ms Pulse width:247us. Measurement Period:20ms Pulse width:481us. Measurement Period:1ms. (PPG1 mode only) Pulse width:481us. Measurement Period:1.25ms. (PPG1 mode only) Pulse width:481us. Measurement Period:2.5ms Pulse width:481us. Measurement Period:5ms. Pulse width:481us. Measurement Period:10ms Pulse width:481us. Measurement Period:20ms Pulse width:949us. Measurement Period:2.5ms. (PPG1 mode only) Pulse width:949us. Measurement Period:5ms Pulse width:949us. Measurement Period:10ms Pulse width:949us. Measurement Period:20ms Default: Pulse width:130us. Measurement Period:1.25ms
RM_OB1203_CFG_DEVICE(x) _PPG_FIFO_ROLLOVER ("x" = 0-1)	Enable the FIFO rollover for PPG mode. Selection: Disabled Enabled Default: Disabled
RM_OB1203_CFG_DEVICE(x) _PPG_FIFO_EMPTY_NUM ("x" = 0-1)	Specify the number of empty FIFO words when the FIFO almost full interrupt is issued (4bits). Min = 0x0 and Max = 0xF Selection: None (Need user to input.) Default: 0xC

Note 1: Do not set same "I2C Communication Device(y)" number for sensor device 0 and sensor device 1.
The "y" = 0-4.

2.7.7 RRH46410 SIS Module Configuration (r_rrh46410_rl_config.h)

The following explains the option names and setting values of this SIS module. The configuration settings shown in following table are set on Smart Configurator.

Configuration Options	Description (Smart Configurator Display)
RM_RRH46410_CFG_PARAM_CHECKING_ENABLE	Specify whether to include code for API parameter checking. Selection: BSP Enabled Disabled Default: BSP
RM_RRH46410_CFG_DEVICE_NUM_MAX	Specify maximum numbers of RRH46410 sensors. Selection: 1 Default: 1
RM_RRH46410_CFG_DEVICE0_OPERATION_MODE	Specify operation mode of RRH46410 sensors. Selection: Not selected IAQ 2nd Gen. IAQ 2nd Gen. Ultra-Low Power PBAQ. Default: Not selected
RM_RRH46410_CFG_DEVICE0_COMMS_INSTANCE	Specify using communication line instance. (Note 1) Selection: I2C Communication Device(x) (x: 0 - 4) Default I2C Communication Device0 (When Device0 is selected, set "g_comms_i2c_device0")
RM_RRH46410_CFG_DEVICE0_COMMS_I2C_CALLBACK	Specify user I2C callback function name. Selection: None (Need user to input.) Default: rrh46410_user_i2c_callback0
RM_RRH46410_CFG_DEVICE0_IRQ_ENABLE	Enable INTC. Selection: Enabled Disabled Default: Disabled
RM_RRH46410_CFG_DEVICE0_IRQ_CALLBACK	Specify user INTC callback function name. Selection: None (Need user to input.) Default: rrh46410_user_irq_callback0
RM_RRH46410_CFG_DEVICE0_IRQ_NUMBER	Specify INTC number. Selection: _INTP0 - _INTP15 Default: _INTP0

Note 1: Be sure to specify a valid communication line number.

2.7.8 ZMOD4XXX SIS Module Configuration (r_zmod4xxx_rl_config.h)

The following explains the option names and setting values of this SIS module. The configuration settings shown in following table are set on Smart Configurator.

Note: INT signal on the following boards is inverted.

- US082-ZMOD4410EVZ
- US082-ZMOD4450EVZ
- US082-ZMOD4510EVZ

Configuration Options	Description (Smart Configurator Display)
RM_ZMOD4XXX_CFG_PARAM_CHECKING_ENABLE	Specify whether to include code for API parameter checking. Selection: BSP Enabled Disabled Default: BSP
RM_ZMOD4XXX_CFG_DEVICE_NUM_MAX	Specify maximum numbers of ZMOD4XXX sensors. Selection: 1 - 2 Default: 1
RM_ZMOD4XXX_CFG_DEVICE(x)_OPERATION_MODE ("x" = 0-1)	Specify operation mode of ZMOD4410, ZMOD4450 and ZMOD4510 sensors. (Note 2, 3) Selection: Not selected IAQ 1st Gen. (Continuous) IAQ 1st Gen. (Low Power) IAQ 2nd Gen. Odor Sulfur-based Odor OAQ 1st Gen. OAQ 2nd Gen. IAQ 2nd Gen. Ultra-Low Power RAQ Rel IAQ. Rel IAQ. Ultra-Low Power PBAQ. Default: Not selected
RM_ZMOD4XXX_CFG_DEVICE(x)_COMMS_INSTANCE ("x" = 0-1)	Specify using communication line instance. (Note 1) Selection: I2C Communication Device(y) (y: 0 - 4) Default: I2C Communication Device(x) (When Device0 is selected, set "g_comms_i2c_device0")
RM_ZMOD4XXX_CFG_DEVICE(x)_COMMS_I2C_CALLBACK CK ("x" = 0-1)	Specify I2C callback function name. Selection: None (Need user to input.) Default: zmod4xxx_user_i2c_callback(x)
RM_ZMOD4XXX_CFG_DEVICE(x)_IRQ_ENABLE ("x" = 0-1)	Enable INTC. Selection: Enabled Disabled Default: Disabled
RM_ZMOD4XXX_CFG_DEVICE(x)_IRQ_CALLBACK ("x" = 0-1)	Specify INTC callback function name. Selection: None (Need user to input.) Default: zmod4xxx_user_irq_callback(x)
RM_ZMOD4XXX_CFG_DEVICE(x)_IRQ_NUMBER ("x" = 0-1)	Specify INTC number. Selection: INTPO - INTPI5 Default: INTPO

Note 1: Do not set same “I2C Communication Device(y)” number for sensor device 0 and sensor device 1. The “y” = 0-4.

Note 2: When creating a project using “LLVM for Renesas RL78” toolchain with the “Make the double data type 64-bits wide” of “Additional CPU Option” is enabled, the library files for this option are needed to set by user itself.

The library files are attached in sub folders under “.\r_zmod4xxx_rx\lib\” in ZMOD4XXX SIS module. “_64bits” is added in the name of these library files.

Replace the library file name with “*_64bits” file name in following figure of “Settings” of “C/C++ Build” in properties of the project after generating the code.

Note 3: In the LLVM project, when changing operation mode, after code generation, the old library name may remain in the archive (library) files for linker settings. If the old library name remains, please manually remove it.

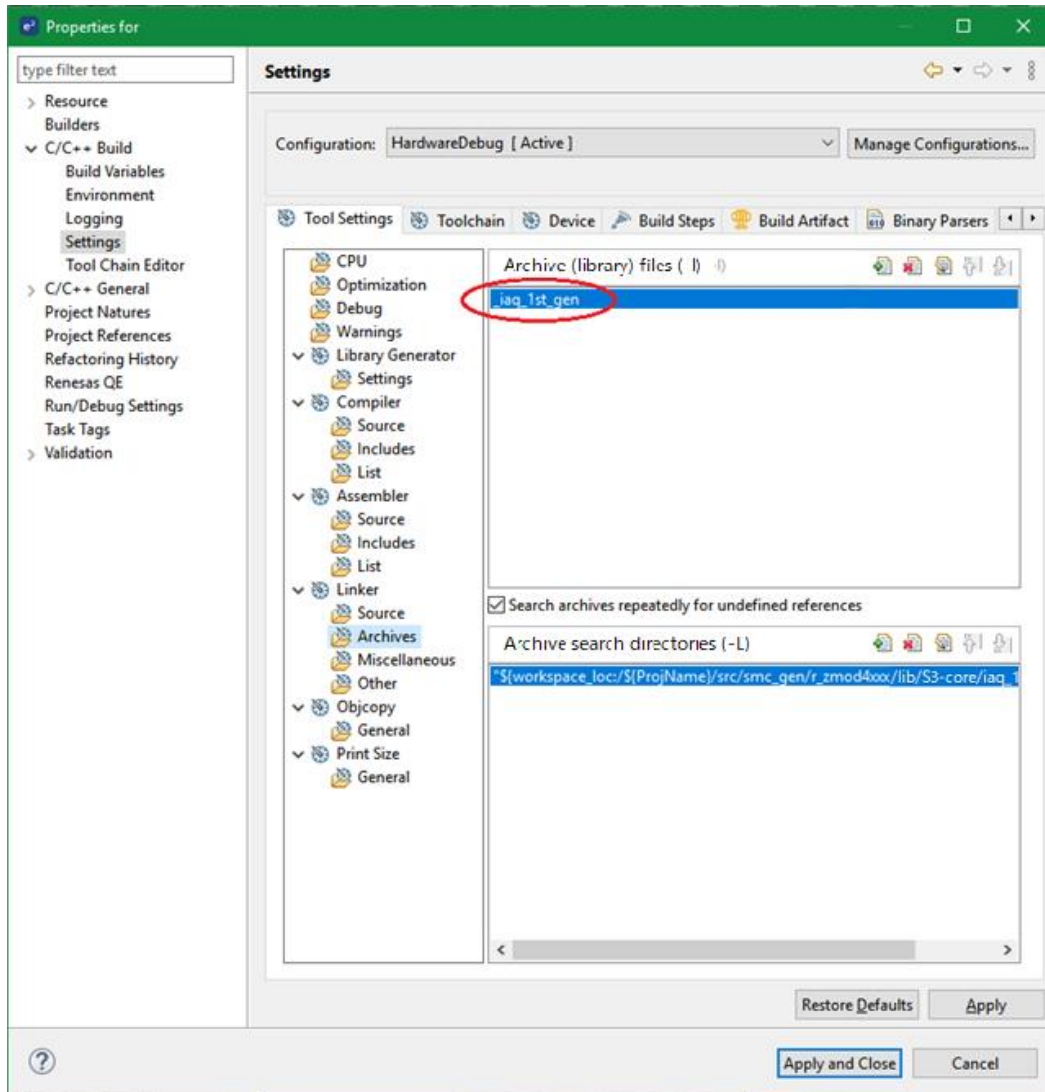

2.7.9 COMMS SIS Module Configuration (r_comms_i2c_rl_config.h)

The following explains the option names and setting values of this SIS module. The configuration settings shown in following table are set on Smart Configurator.

Configuration Options	Description (Smart Configurator Display)
RM_COMMS_I2C_CFG_PARAM_CHECKING_ENABLE	Specify whether to include code for API parameter checking. Selection: BSP Enabled Disabled Default: BSP
COMMS_I2C_CFG_BUS_NUM_MAX	Set the numbers (max.) of I2C buses. Selection: Unused, 1-5 Default: 1
COMMS_I2C_CFG_DEVICE_NUM_MAX	Set the numbers (max.) of I2C devices. Selection: Unused, 1-5 Default: 1
COMMS_I2C_CFG_BUS(x)_DRIVER_TYPE ("x" = 0-4)	Specify the driver type of I2C bus. Selection: Not selected IICA SAU IIC Default: Not selected
COMMS_I2C_CFG_BUS(x)_COMPONENT ("x" = 0-4)	Specify the component name of I2C bus. Selection: None Default: Config_IIC00 (Need user to input)
COMMS_I2C_CFG_DEVICE(x)_BUS_CH ("x" = 0-4)	Specify the bus configuration instance. Default: g_comms_i2c_bus0_extended_cfg. (Need user to input)
COMMS_I2C_CFG_DEVICE(x)_SLAVE_ADDR ("x" = 0-4)	Specify the slave address of the I2C device. Selection: None Default: 0x00 (Need user to input)
COMMS_I2C_CFG_DEVICE(x)_CALLBACK ("x" = 0-4)	Specify Callback function of the I2C device. Selection: None Default: comms_i2c_user_callback0 (Need user to input)

2.8 Code Size

Typical code sizes associated with this SIS module are listed below.

The ROM (code and constants) and RAM (global data) sizes are determined by the build-time configuration options described in "2.7 Configuration Overview". The table lists reference values when the C compiler's compile options are set to their default values, as described in "2.3 Supported Toolchains".

The compiler option default values.

optimization level: 2,
 optimization type: for size
 data endianness: little-endian

The code size varies depending on the C compiler version and compile options.

The values in the table below are confirmed under the following conditions.

Component Version: IIC Communication (Master mode) Ver.1.5.1

Compiler Version:

Renesas Electronics C/C++ Compiler Package for RL78 Family V1.13.00

(The option of "-lang = c99" is added to the default settings of the integrated development environment.)

Configuration Options: Default settings

OS supporting	MCU	SIS Module	Category	Numbers	Condition
Non	RL78/G23	HS300x	ROM	544 bytes	Programming mode disabled
			RAM	22 bytes	
		HS400x	ROM	732 bytes	No-Hold Measurement is selected. The code size is different depended on the selected measurement type.
			RAM	40 bytes	
		FS2012	ROM	406 bytes	
			RAM	15 bytes	
		FS3000	ROM	398 bytes	
			RAM	14 bytes	
		FS1015	ROM	802 bytes	
			RAM	14 bytes	
		ZMOD4XXX	ROM	6,917 bytes	ZMOD4410 IAQ 2nd Gen. The code size is different depended on the selected operation mode.
			RAM	368 bytes	
		RRH46410	ROM	1,722 bytes	IAQ 2nd Gen. The code size is different depended on the selected operation mode.
			RAM	60 bytes	
		OB1203	ROM	2,569 bytes	OB1203 Light mode and PPG mode. The code size is different depended on the selected operation mode.
			RAM	84 bytes	
		COMMS	ROM	961 bytes	When using one device.
			RAM	50 bytes	

2.9 Parameters

The API function arguments are shown below.

The structures of “configuration structure” and “control structure” are used as parameters type. These structures are described along with the API function prototype declaration.

The configuration structure is used for the initial configuration of each Sensor SIS module and COMMS SIS module during the module open API call. The configuration structure is used purely as an input into each module.

The control structure is used as a unique identifier for each module instance of each Sensor SIS and COMMS SIS module. It contains memory required by the module. Elements in the control structure are owned by the associated module and must not be modified by the application. The user allocates storage for a control structure, often as a global variable, then sends a pointer to it into the module open API call for the module.

2.9.1 Configuration Structure and Control Structure of FS1015 SIS Module

(1) Configuration Struct `rm_fsxxxx_cfg_t`

Refer to “2.9.3(1) Configuration Struct `rm_fsxxxx_cfg_t`”.

(2) Control Struct `rm_fsxxxx_ctrl_t`

This is FS1015 SIS module control block and allocates an instance specific control block to pass into the FS1015 API calls. This structure is implemented as “`rm_fs1015_instance_ctrl_t`” located in “`rm_fs1015.h`” file.

*/** FS1015 Control Block */*

```
typedef struct rm_fs1015_instance_ctrl
```

```
{
    uint32_t          open;                ///< Open flag
    rm_fsxxxx_cfg_t  const * p_cfg;        ///< Pointer to FS1015 Configuration
    rm_comms_instance_t const * p_comms_i2c_instance; ///< Pointer of I2C Communications Middleware instance
    structure
    void const       * p_context;         ///< Pointer to the user-provided context
```

/ Pointer to callback and optional working memory */*

```
void (* p_callback)(rm_fsxxxx_callback_args_t * p_args);
} rm_fs1015_instance_ctrl_t;
```

2.9.2 Configuration Structure and Control Structure of FS2012 SIS Module

(1) Configuration Struct `rm_fsxxxx_cfg_t`

Refer to “2.9.3(1) Configuration Struct `rm_fsxxxx_cfg_t`”;

(2) Control Struct `rm_fsxxxx_ctrl_t`

This is FS2012 SIS module control block and allocates an instance specific control block to pass into the FS2012 API calls. This structure is implemented as “`rm_fs2012_instance_ctrl_t`” located in “`rm_fs2012.h`” file.

```
/** FS2012 Control Block */
```

```
typedef struct rm_fs2012_instance_ctrl
```

```
{
```

```
    uint32_t                open;                ///< Open flag
```

```
    rm_fsxxxx_cfg_t const   * p_cfg;             ///< Pointer to FS2012 Configuration
```

```
    rm_comms_instance_t const * p_comms_i2c_instance; ///< Pointer of I2C Communications Middleware instance structure
```

```
    void const              * p_context;         ///< Pointer to the user-provided context
```

```
    /* Pointer to callback and optional working memory */
```

```
    void (* p_callback)(rm_fsxxxx_callback_args_t * p_args);
```

```
} rm_fs2012_instance_ctrl_t;
```

2.9.3 Configuration Structure and Control Structure of FS3000 SIS Module

(1) Configuration Struct `rm_fsxxxx_cfg_t`

This structure is located in "rm_fsxxxx_api.h" file.

```
/** FSXXXX Configuration */
typedef struct st_rm_fsxxxx_cfg
{
    rm_comms_instance_t const * p_instance;    ///< Pointer to Communications Middleware instance.
    void const * p_context;                   ///< Pointer to the user-provided context.
    void const * p_extend;                    ///< Pointer to extended configuration by instance of interface.
    void (* p_callback)(rm_fsxxxx_callback_args_t * p_args);    ///< Pointer to callback function.
} rm_fsxxxx_cfg_t;
```

(2) Control Struct `rm_fsxxxx_ctrl_t`

This is FS3000 SIS module control block and allocates an instance specific control block to pass into the FS3000 API calls. This structure is implemented as "rm_fs3000_instance_ctrl_t" located in "rm_fs3000.h" file.

```
/** FS3000 Control Block */
typedef struct rm_fs3000_instance_ctrl
{
    uint32_t open;                            ///< Open flag
    rm_fsxxxx_cfg_t const * p_cfg;             ///< Pointer to FS3000 Configuration
    rm_comms_instance_t const * p_comms_i2c_instance;    ///< Pointer of I2C Communications Middleware instance
    structure
    void const * p_context;                    ///< Pointer to the user-provided context

    /* Pointer to callback and optional working memory */
    void (* p_callback)(rm_fsxxxx_callback_args_t * p_args);
} rm_fs3000_instance_ctrl_t;
```

2.9.4 Configuration Structure and Control Structure of HS300x SIS Module

(1) Configuration Struct `rm_hs300x_cfg_t`

This structure is located in “`rm_hs300x_api.h`” file.

```
/** HS300X Configuration */
typedef struct st_rm_hs300x_cfg
{
    rm_comms_instance_t const * p_instance;    ///< Pointer to Communications Middleware instance
    void const * p_context;                  ///< Pointer to the user-provided context
    void const * p_extend;                   ///< Pointer to extended configuration by instance of interface
    void (* p_callback)(rm_hs300x_callback_args_t * p_args);    ///< Pointer to callback function
} rm_hs300x_cfg_t;
```

(2) Control Struct `rm_hs300x_ctrl_t`

This is HS300x SIS module control block and allocates an instance specific control block to pass into the HS300x API calls. This structure is implemented as “`rm_hs300x_instance_ctrl_t`” located in “`rm_hs300x.h`” file.

```
/** HS300x Control Block */
typedef struct rm_hs300x_instance_ctrl
{
    uint32_t open;                            ///< Open flag
    rm_hs300x_cfg_t const * p_cfg;            ///< Pointer to HS300X Configuration
    rm_comms_instance_t const * p_comms_i2c_instance;    ///< Pointer of I2C Communications Middleware instance
    structure
    void const * p_context;                    ///< Pointer to the user-provided context
    rm_hs300x_programmng_mode_params_t programming_mode;    ///< Programming mode flag
    uint8_t buf[3];                            ///< Buffer for I2C communications

    /* Pointer to callback and optional working memory */
    void (* p_callback)(rm_hs300x_callback_args_t * p_args);
} rm_hs300x_instance_ctrl_t;
```

2.9.5 Configuration Structure and Control Structure of HS400x SIS Module

(1) Configuration Struct `rm_hs400x_cfg_t`

This structure is located in “`rm_hs400x_api.h`” file.

```
/** HS400X Configuration */
```

```
typedef struct st_rm_hs400x_cfg
```

```
{
```

```
    rm_hs400x_temperature_resolution_t const    temperature_resolution;    ///< Resolution for temperature
```

```
    rm_hs400x_humidity_resolution_t const      humidity_resolution;        ///< Resolution for humidity
```

```
    rm_hs400x_periodic_measurement_frequency_t const    frequency;                ///< Frequency for periodic measurement
```

```
    rm_comms_instance_t const * p_comms_instance;    ///< Pointer to Communications Middleware instance
```

```
    void const * p_context;                        ///< Pointer to the user-provided context
```

```
    void const * p_extend;                        ///< Pointer to extended configuration by instance of interface
```

```
    void (* p_comms_callback)(rm_hs400x_callback_args_t * p_args);    ///< Pointer to callback function
```

```
} rm_hs400x_cfg_t;
```

(2) Control Struct `rm_hs400x_ctrl_t`

This is HS400x SIS module control block and allocates an instance specific control block to pass into the HS400x API calls. This structure is implemented as “`rm_hs400x_instance_ctrl_t`” located in “`rm_hs400x.h`” file.

```
/** HS400x Control Block */
```

```
typedef struct rm_hs400x_instance_ctrl
```

```
{
```

```
    uint32_t open;                                ///< Open flag
```

```
    rm_hs400x_cfg_t const * p_cfg;                ///< Pointer to HS400X Configuration
```

```
    rm_comms_instance_t const * p_comms_i2c_instance;    ///< Pointer of I2C Communications Middleware instance structure
```

```
    void const * p_context;                        ///< Pointer to the user-provided context
```

```
    rm_hs400x_init_process_params_t init_process_params;    ///< For the initialization process.
```

```
    uint8_t resolution_register;    ///< Register for temperature and humidity measurement resolution settings
```

```
    uint8_t periodic_measurement_register[2];    ///< Register for periodic measurement settings
```

```
    volatile bool periodic_measurement_stop;    ///< Flag for stop of periodic measurement
```

```
    volatile bool no_hold_measurement_read;    ///< Flag for data read of No-Hold measurement
```

```
    uint8_t write_buf[18];                        ///< Buffer for data write
```

```
    /* Pointer to callback and optional working memory */
```

```
    void (* p_comms_callback)(rm_hs400x_callback_args_t * p_args);    ///< I2C Communications callback
```

```
} rm_hs400x_instance_ctrl_t;
```

2.9.6 Configuration Structure and Control Structure of OB1203 SIS Module

(1) Configuration Struct `rm_ob1203_cfg_t`

This structure is located in “`rm_ob1203x_api.h`” file.

```

/** OB1203 configuration block */
typedef struct st_rm_ob1203_cfg
{
    #if BSP_CFG_RTOS
        rm_ob1203_semaphore_t const * p_semaphore; ///< The semaphore to wait for callback. This is used for
        another data read/write after a communication
        uint32_t semaphore_timeout;                ///< timeout for callback.
    #endif
        uint32_t semaphore_timeout;                ///< timeout for callback.
        rm_comms_instance_t const * p_comms_instance; ///< Pointer to Communications Middleware instance.
        void const * p_irq_instance;                ///< Pointer to IRQ instance.
        void const * p_context;                    ///< Pointer to the user-provided context.
        void const * p_extend;                    ///< Pointer to extended configuration by instance of interface.
        void (* p_comms_callback)(rm_ob1203_callback_args_t * p_args);    ///< I2C Communications callback
        void (* p_irq_callback)(rm_ob1203_callback_args_t * p_args);      ///< IRQ callback
} rm_ob1203_cfg_t;

```

(2) Control Struct `rm_ob1203_ctrl_t`

This is OB1203 SIS module control block and allocates an instance specific control block to pass into the OB1203 API calls. This structure is implemented as “`rm_ob1203_instance_ctrl_t`” located in “`rm_ob1203.h`” file.

```

/** OB1203 control block */
typedef struct st_rm_ob1203_instance_ctrl
{
    uint32_t open;                                ///< Open flag
    rm_ob1203_cfg_t const * p_cfg;                ///< Pointer to OB1203 Configuration
    uint8_t buf[8];                               ///< Buffer for I2C communications
    rm_ob1203_init_process_params_t init_process_params; ///< For the initialization process.
    uint8_t register_address;                    ///< Register address to access
    volatile rm_ob1203_device_status_t * p_device_status;    ///< Pointer to device status.
    volatile rm_ob1203_fifo_info_t * p_fifo_info;    ///< Pointer to FIFO information structure.
    volatile bool fifo_reset;                    ///< Flag for FIFO reset for PPG mode
    volatile bool prox_gain_update;              ///< Flag for gain update for Proximity mode
    volatile bool interrupt_bits_clear;          ///< Flag for clearing interrupt bits.
    rm_comms_instance_t const * p_comms_i2c_instance;    ///< Pointer of I2C Communications Middleware instance
    structure
    rm_ob1203_mode_extended_cfg_t * p_mode;    ///< Pointer of OB1203 operation mode extended configuration
    void const * p_irq_instance;                ///< Pointer to IRQ instance.
    void const * p_context;                    ///< Pointer to the user-provided context

    /* Pointer to callback and optional working memory */
    void (* p_comms_callback)(rm_ob1203_callback_args_t * p_args);    ///< I2C Communications callback
    void (* p_irq_callback)(rm_ob1203_callback_args_t * p_args);      ///< IRQ callback
} rm_ob1203_instance_ctrl_t;

```

2.9.7 Configuration Structure and Control Structure of RRH46410 SIS Module

(1) Configuration Struct `rm_zmod4xxx_cfg_t`

Refer to “2.9.8(1) Configuration Struct `rm_zmod4xxx_cfg_t`”.

(2) Control Struct `rm_zmod4xxx_ctrl_t`

This is RRH46410 SIS module control block and allocates an instance specific control block to pass into the RRH46410 API calls. This structure is implemented as “`rm_rrh46410_instance_ctrl_t`” located in “`rm_rrh46410.h`” file.

```

/** RRH46410 control block */
typedef struct st_rm_rrh46410_instance_ctrl
{
    uint32_t    open;                               ///< Open flag
    uint8_t     write_buf[RM_RRH46410_MAX_I2C_BUF_SIZE];  ///< Write buffer for I2C communications
    uint8_t     read_buf[RM_RRH46410_MAX_I2C_BUF_SIZE];  ///< Read buffer for I2C communications
    uint8_t     * p_read_data    ///< Pointer to read data. This is used for checking error code and checksum in callback
    uint8_t     read_bytes       ///< Read bytes. This is used for checking error code and checksum in callback
    volatile uint8_t prev_sample_id;  ///< Previous sample ID. This is used for checking if sensor is in stabilization
    volatile int16_t warmup_counts  ///< Counts for warning up. This is used for checking if sensor is in stabilization
    volatile rm_zmod4xxx_event_t    event;                ///< Callback event
    rm_rrh46410_init_process_params_t init_process_params;  ///< For the initialization process
    rm_zmod4xxx_cfg_t const * p_cfg;                       ///< Pointer of configuration block
    rm_comms_instance_t const * p_comms_i2c_instance;  ///< Pointer of I2C Communications Middleware instance
    structure
    void const * p_irq_instance;                          ///< Pointer to IRQ instance
    void const * p_context;                               ///< Pointer to the user-provided context

    /* Pointer to callback and optional working memory */
    void (* p_comms_callback)(rm_zmod4xxx_callback_args_t * p_args);  ///< I2C Communications callback
    void (* p_irq_callback)(rm_zmod4xxx_callback_args_t * p_args);    ///< IRQ callback
} rm_rrh46410_instance_ctrl_t;

```

2.9.8 Configuration Structure and Control Structure of ZMOD4xxx SIS Module

(1) Configuration Struct `rm_zmod4xxx_cfg_t`

This structure is located in “`rm_zmod4xxx_api.h`” file.

```
/** ZMOD4XXX configuration block */
typedef struct st_rm_zmod4xxx_cfg
{
    rm_comms_instance_t const * p_comms_instance; ///< Pointer to Communications Middleware instance
    void const * p_irq_instance;                ///< Pointer to IRQ instance
    void const * p_context;                     ///< Pointer to the user-provided context
    void const * p_extend;                      ///< Pointer to extended configuration by instance of interface
    void (* p_comms_callback)(rm_zmod4xxx_callback_args_t * p_args); ///< I2C Communications callback
    void (* p_irq_callback)(rm_zmod4xxx_callback_args_t * p_args);   ///< IRQ callback
} rm_zmod4xxx_cfg_t;
```

(2) Control Struct `rm_zmod4xxx_ctrl_t`

This is ZMOD4XXX SIS module control block and allocates an instance specific control block to pass into the ZMOD4XXX API calls. This structure is implemented as “`rm_zmod4xxx_instance_ctrl_t`” located in “`rm_zmod4xxx.h`” file.

```
/** ZMOD4XXX control block */
typedef struct st_rm_zmod4xxx_instance_ctrl
{
    uint32_t open;                ///< Open flag
    uint8_t  buf[RM_ZMOD4XXX_MAX_I2C_BUF_SIZE];  ///< Buffer for I2C communications
    uint8_t  register_address;    ///< Register address to access
    rm_zmod4xxx_status_params_t status;        ///< Status parameter
    volatile bool dev_err_check;  ///< Flag for checking device error
    volatile rm_zmod4xxx_event_t event;        ///< Callback event
    rm_zmod4xxx_init_process_params_t init_process_params; ///< For the initialization process.
    rm_zmod4xxx_cfg_t const * p_cfg;           ///< Pointer of configuration block
    rm_comms_instance_t const * p_comms_i2c_instance; ///< Pointer of I2C Communications Middleware instance structure
    rm_zmod4xxx_lib_extended_cfg_t * p_zmod4xxx_lib;  ///< Pointer of ZMOD4XXX Lib extended configuration
    void const * p_irq_instance;                ///< Pointer to IRQ(INTP) instance.
    void const * p_context;                    ///< Pointer to the user-provided context

    /* Pointer to callback and optional working memory */
    void (* p_comms_callback)(rm_zmod4xxx_callback_args_t * p_args); ///< I2C Communications callback
    void (* p_irq_callback)(rm_zmod4xxx_callback_args_t * p_args);   ///< IRQ(INTP) callback
} rm_zmod4xxx_instance_ctrl_t;
```

2.9.9 Configuration Structure and Control Structure of COMMS SIS Module

(1) Configuration Struct `rm_comms_cfg_t`

This structure is located in “`rm_comms_api.h`” file.

```
/** Communications middleware configuration block */
typedef struct st_rm_comms_cfg
{
    uint32_t      semaphore_timeout;    ///< timeout for callback.
    void (* p_callback)(rm_comms_callback_args_t * p_args);    ///< Pointer to callback function, mostly used if
    using non-blocking functionality.
    void const    * p_lower_level_cfg;    ///< Pointer to lower level driver configuration structure.
    void const    * p_extend;            ///< Pointer to extended configuration by instance of interface.
    void const    * p_context;          ///< Pointer to the user-provided context
} rm_comms_cfg_t;
```

(2) Control Struct `rm_comms_ctrl_t`

This is COMMS SIS module control block and allocates an instance specific control block to pass into the COMMS API calls. This structure is implemented as “`rm_comms_i2c_instance_ctrl_t`” located in “`rm_comms_i2c.h`” file.

```
/** Communications middleware control structure. */
typedef struct st_rm_comms_i2c_instance_ctrl
{
    rm_comms_cfg_t const    * p_cfg;            ///< middleware configuration.
    rm_comms_i2c_bus_extended_cfg_t * p_bus;    ///< Bus using this device;
    void                    * p_lower_level_cfg;    ///< Used to reconfigure I2C driver
    uint32_t                open;                ///< Open flag.
    uint32_t                transfer_data_bytes;    ///< Size of transfer data.
    uint8_t                 * p_transfer_data;    ///< Pointer to transfer data buffer.

    /* Pointer to callback and optional working memory */
    void (* p_callback)(rm_comms_callback_args_t * p_args);

    void const              * p_context;        ///< Pointer to the user-provided context
} rm_comms_i2c_instance_ctrl_t;
```

2.10 Return Values

The API function return values are shown below.

This enumeration is listed in `fsp_common_api.h` which is included in RL78BSP (Board Support Package Module) Ver.1.30 or higher.

```
typedef enum e_fsp_err
{
    FSP_SUCCESS = 0,

    FSP_ERR_ASSERTION           = 1,    ///< A critical assertion has failed
    FSP_ERR_INVALID_POINTER    = 2,    ///< Pointer points to invalid memory location
    FSP_ERR_INVALID_ARGUMENT   = 3,    ///< Invalid input parameter
    FSP_ERR_INVALID_CHANNEL    = 4,    ///< Selected channel does not exist
    FSP_ERR_INVALID_MODE       = 5,    ///< Unsupported or incorrect mode
    FSP_ERR_UNSUPPORTED        = 6,    ///< Selected mode not supported by this API
    FSP_ERR_NOT_OPEN           = 7,    ///< Requested channel is not configured or API not open
    FSP_ERR_IN_USE             = 8,    ///< Channel/peripheral is running/busy
    FSP_ERR_OUT_OF_MEMORY      = 9,    ///< Allocate more memory in the driver's cfg.h
    FSP_ERR_HW_LOCKED          = 10,   ///< Hardware is locked
    FSP_ERR_IRQ_BSP_DISABLED   = 11,   ///< IRQ not enabled in BSP
    FSP_ERR_OVERFLOW           = 12,   ///< Hardware overflow
    FSP_ERR_UNDERFLOW          = 13,   ///< Hardware underflow
    FSP_ERR_ALREADY_OPEN       = 14,   ///< Requested channel is already open in a different configuration
    FSP_ERR_APPROXIMATION      = 15,   ///< Could not set value to exact result
    FSP_ERR_CLAMPED            = 16,   ///< Value had to be limited for some reason
    FSP_ERR_INVALID_RATE       = 17,   ///< Selected rate could not be met
    FSP_ERR_ABORTED            = 18,   ///< An operation was aborted
    FSP_ERR_NOT_ENABLED        = 19,   ///< Requested operation is not enabled
    FSP_ERR_TIMEOUT            = 20,   ///< Timeout error
    FSP_ERR_INVALID_BLOCKS     = 21,   ///< Invalid number of blocks supplied
    FSP_ERR_INVALID_ADDRESS    = 22,   ///< Invalid address supplied
    FSP_ERR_INVALID_SIZE       = 23,   ///< Invalid size/length supplied for operation
    FSP_ERR_WRITE_FAILED       = 24,   ///< Write operation failed
    FSP_ERR_ERASE_FAILED       = 25,   ///< Erase operation failed
    FSP_ERR_INVALID_CALL       = 26,   ///< Invalid function call is made
    FSP_ERR_INVALID_HW_CONDITION = 27,  ///< Detected hardware is in invalid condition
    FSP_ERR_INVALID_FACTORY_FLASH = 28, ///< Factory flash is not available on this MCU
    FSP_ERR_INVALID_STATE      = 30,   ///< API or command not valid in the current state
    FSP_ERR_NOT_ERASED         = 31,   ///< Erase verification failed
    FSP_ERR_SECTOR_RELEASE_FAILED = 32, ///< Sector release failed
    FSP_ERR_NOT_INITIALIZED    = 33,   ///< Required initialization not complete
    FSP_ERR_NOT_FOUND          = 34,   ///< The requested item could not be found
    FSP_ERR_NO_CALLBACK_MEMORY = 35,   ///< Non-secure callback memory not provided for non-secure callback
    FSP_ERR_BUFFER_EMPTY       = 36,   ///< No data available in buffer

    /* Start of RTOS only error codes */
    FSP_ERR_INTERNAL           = 100,   ///< Internal error
    FSP_ERR_WAIT_ABORTED       = 101,   ///< Wait aborted

    /* Start of Sensor specific */
    FSP_ERR_SENSOR_INVALID_DATA = 0x30000, ///< Data is invalid.
    FSP_ERR_SENSOR_IN_STABILIZATION = 0x30001, ///< Sensor is stabilizing.
    FSP_ERR_SENSOR_MEASUREMENT_NOT_FINISHED = 0x30002, ///< Measurement is not finished.

    /* Start of COMMS specific */
    FSP_ERR_COMMS_BUS_NOT_OPEN = 0x40000, ///< Bus is not open.
} fsp_err_t;
```

2.11 Adding the SIS Module to Your Project

This module must be added to each project in which it is used. Renesas recommends using “Smart Configurator” described in (1) or (2). However, “Smart Configurator” only supports some RL78 devices.

(1) Adding the SIS Module to Your Project Using “Smart Configurator” in e² studio

By using the “Smart Configurator” in e² studio, the SIS module is automatically added to your project. Refer to “RL78 Smart Configurator User’s Guide: e² studio(R20AN0579)” for details.

(2) Adding the SIS Module to Your Project Using “Smart Configurator” on CS+

By using the “Smart Configurator Standalone version” in CS+, the SIS module is automatically added to your project. Refer to “RL78 Smart Configurator User’s Guide: CS+ (R20AN0580)” for details.

3. FS1015 API Functions

3.1 RM_FS1015_Open()

This function opens and configures the FS1015 SIS module. This function must be called before calling any other FS1015 API functions.

Format

```
fsp_err_t RM_FS1015_Open (  
    rm_fsxxxx_ctrl_t      * const p_ctrl,  
    rm_fsxxxx_cfg_t const * const p_cfg  
)
```

Parameters

p_ctrl

Pointer to control structure

The members of this structure are shown in 2.9.1(2) Control Struct `rm_fsxxxx_ctrl_t`.

p_cfg

Pointer to configuration structure

The members of this structure are shown in 2.9.1(1) Configuration Struct `rm_fsxxxx_cfg_t`.

Return Values

FSP_SUCCESS FS1015 successfully configured.

FSP_ERR_ASSERTION Null pointer, or one or more configuration options is invalid.

FSP_ERR_ALREADY_OPEN Module is already open. This module can only be opened once.

Properties

Prototyped in `rm_fs1015.h`

Description

This function opens and configures the FS1015 SIS module.

This function copies the contents in “`p_cfg`” structure to the member “`p_ctrl->p_cfg`” in “`p_ctrl`” structure.

This function does configurations by setting the members of “`p_ctrl`” structure as following:

- Sets related instance of COMMS SIS module.
- Sets callback and context.
- Sets an open flag.

This function calls an open API of COMMS SIS module to open communication middleware after all above initializations are done.

Special Notes

None

3.2 RM_FS1015_Close()

This function disables specified FS1015 control block.

Format

```
fsp_err_t RM_FS1015_Close (rm_fsxxxx_ctrl_t * const p_ctrl)
```

Parameters

p_ctrl

Pointer to control structure

The members of this structure are shown in 2.9.1(2) Control Struct rm_fsxxxx_ctrl_t.

Return Values

FSP_SUCCESS	Successfully closed.
FSP_ERR_ASSERTION	Null pointer passed as a parameter.
FSP_ERR_NOT_OPEN	Module is not open.

Properties

Prototyped in rm_fs1015.h

Description

This function calls a close API of COMMS SIS module to close communication middleware.

This function clears an open flag after all above are done.

Special Notes

None

3.3 RM_FS1015_Read()

This function reads ADC data from FS1015 sensor.

Format

```
fsp_err_t RM_FS1015_Read (  
    rm_fsxxxx_ctrl_t      * const p_ctrl,  
    rm_fsxxxx_raw_data_t  * const p_raw_data  
)
```

Parameters

p_ctrl

Pointer to control structure

The members of this structure are shown in 2.9.1(2) Control Struct `rm_fsxxxx_ctrl_t`.

p_raw_data

Pointer to raw data structure for storing the read ADC data from FS1015 sensor

*/** FSXXXX raw data */*

```
typedef struct st_rm_fsxxxx_raw_data
```

```
{
```

```
    uint8_t      adc_data[5];
```

```
} rm_fsxxxx_raw_data_t;
```

Return Values

FSP_SUCCESS

Successfully data decoded.

FSP_ERR_ASSERTION

Null pointer, or one or more configuration options is invalid.

FSP_ERR_NOT_OPEN

Module is not open.

Properties

Prototyped in `rm_fs1015.h`

Description

This function reads ADC data from FS1015 sensor.

The read API of COMMS SIS module is called in this function.

The ADC data read from FS1015 sensor is stored in “`p_raw_data`” structure. The read data length is 3 bytes according to FS1015 datasheet.

The detail information is described in “Digital Output Measurements” of FS1015 Series Datasheet.

Special Notes

None

3.4 RM_FS1015_DataCalculate()

This function calculates air velocity value [m/sec] from ADC data.

Format

```
fsp_err_t RM_FS1015_DataCalculate (
    rm_fsxxxx_ctrl_t      * const p_ctrl,
    rm_fsxxxx_raw_data_t * const p_raw_data,
    rm_fsxxxx_data_t     * const p_fs1015_data
)
```

Parameters

p_ctrl

Pointer to control structure

The members of this structure are shown in 2.9.1(2) Control Struct `rm_fsxxxx_ctrl_t`.

p_raw_data

Pointer to raw data structure for storing the read ADC data from FS1015 sensor

*/** FSXXXX raw data */*

```
typedef struct st_rm_fsxxxx_raw_data
```

```
{
    uint8_t      adc_data[5];
} rm_fsxxxx_raw_data_t;
```

p_fs1015_data

Pointer to FS1015 sensor measurement results data structure

*** FSXXXX data block */*

```
typedef struct st_rm_fsxxxx_data
```

```
{
    rm_fsxxxx_sensor_data_t  flow;
    uint32_t                 count;
} rm_fsxxxx_data_t;
```

The “`rm_fsxxxx_sensor_data_t`” structure is defined as following.

*/** FSXXXX sensor data block */*

```
typedef struct st_rm_fsxxxx_sensor_data
```

```
{
    int16_t      integer_part;
    int16_t      decimal_part;    ///< To two decimal places
} rm_fsxxxx_sensor_data_t;
```

Return Values

FSP_SUCCESS	Successfully data decoded.
FSP_ERR_ASSERTION	Null pointer, or one or more configuration options is invalid.
FSP_ERR_NOT_OPEN	Module is not open.
FSP_ERR_SENSOR_INVALID_DATA	Data is invalid.

Properties

Prototyped in `rm_fs1015.h`

Description

This function calculates the air velocity value [m/sec] from the ADC data stored in “`rm_fsxxxx_raw_data_t p_raw_data`” and stores the calculated results to “`rm_fsxxxx_data_t p_fs1015_data`” structure.

This function calculates the air velocity value [m/sec] from the count value.

The relationships between Air velocity and Count value are as follows.

- FS1015-1005

Air Velocity (meter/sec)	Analog Output (Volt)	Digital Output (Counts)
0	0.5	409
1.07	1.118	915
2.01	1.858	1522
3	2.522	2066
3.97	3.08	2523
4.96	3.55	2908
5.98	3.075	3256
6.99	4.361	3572
7.23	4.5	3686

The detail information is described in “Flow Output Curve” of FS1015 Series Datasheet.

Special Notes

None

3.5 fs1015_user_callback()

This is a callback function registered with Smart Configurator by user.

The default name of callback function for I2C is fs1015_user_callback0, fs1015_user_callback1.

Format

```
void fs1015_user_callback0(rm_fsxxxx_callback_args_t * p_args)
void fs1015_user_callback1(rm_fsxxxx_callback_args_t * p_args)
```

Parameters

p_args

```
/** FSXXXX callback parameter definition */
typedef struct st_rm_fsxxxx_callback_args
{
    void const          * p_context;
    rm_fsxxxx_event_t   event;
} rm_fsxxxx_callback_args_t;
```

Return Values

None

Properties

Prototyped in rm_fs1015_instance.c

Description

None

Special Notes

None

3.6 Usage Example of FS1015 Control Module

Refer to a sample code included in Application Note “RA Family, RX Family, RL78 Family, RZ Family FS1015 Sample Software Manual (R01AN6049)”.

4. FS2012 API Functions

4.1 RM_FS2012_Open()

This function opens and configures the FS2012 SIS module. This function must be called before calling any other FS2012 API functions.

Format

```
fsp_err_t RM_FS2012_Open (
    rm_fsxxxx_ctrl_t      * const p_ctrl,
    rm_fsxxxx_cfg_t const * const p_cfg
)
```

Parameters

p_ctrl

Pointer to control structure

The members of this structure are shown in 2.9.2(2) Control Struct `rm_fsxxxx_ctrl_t`.

p_cfg

Pointer to configuration structure

The members of this structure are shown in 2.9.2(1) Configuration Struct `rm_fsxxxx_cfg_t`.

Return Values

FSP_SUCCESS FS2012 successfully configured.

FSP_ERR_ASSERTION Null pointer, or one or more configuration options is invalid.

FSP_ERR_ALREADY_OPEN Module is already open. This module can only be opened once.

Properties

Prototyped in `rm_fs2012.h`

Description

This function opens and configures the FS2012 SIS module.

This function copies the contents in “`p_cfg`” structure to the member “`p_ctrl->p_cfg`” in “`p_ctrl`” structure.

This function does configurations by setting the members of “`p_ctrl`” structure as following:

- Sets related instance of COMMS SIS module
- Sets callback and context
- Sets open flag

This function calls open API of COMMS SIS module to open communication middleware after all above initializations are done.

Special Notes

None

4.2 RM_FS2012_Close()

This function disables specified FS2012 control block.

Format

```
fsp_err_t RM_FS2012_Close (rm_fsxxxx_ctrl_t * const p_ctrl)
```

Parameters

p_ctrl

Pointer to control structure

The members of this structure are shown in 2.9.2(2) Control Struct `rm_fsxxxx_ctrl_t`.

Return Values

FSP_SUCCESS	Successfully closed.
FSP_ERR_ASSERTION	Null pointer passed as a parameter.
FSP_ERR_NOT_OPEN	Module is not open.

Properties

Prototyped in `rm_fs2012.h`

Description

This function calls close API of COMMS SIS module to close communication middleware.

This function clears open flag after all above are done.

Special Notes

None

4.3 RM_FS2012_Read()

This function reads ADC data from FS2012 sensor.

Format

```
fsp_err_t RM_FS2012_Read (  
    rm_fsxxxx_ctrl_t      * const p_ctrl,  
    rm_fsxxxx_raw_data_t  * const p_raw_data  
)
```

Parameters

p_ctrl

Pointer to control structure

The members of this structure are shown in 2.9.2(2) Control Struct `rm_fsxxxx_ctrl_t`.

p_raw_data

Pointer to raw data structure for storing the read ADC data from FS2012 sensor

*/** FSXXXX raw data */*

```
typedef struct st_rm_fsxxxx_raw_data
```

```
{
```

```
    uint8_t    adc_data[5];
```

```
} rm_fsxxxx_raw_data_t;
```

Return Values

FSP_SUCCESS

Successfully data decoded.

FSP_ERR_ASSERTION

Null pointer, or one or more configuration options is invalid.

FSP_ERR_NOT_OPEN

Module is not open.

Properties

Prototyped in `rm_fs2012.h`

Description

This function reads ADC data from FS2012 sensor.

The read API of COMMS SIS module is called in this function.

The ADC data read from FS2012 sensor is stored in “`p_raw_data`” structure. The read data length is 2 bytes according to FS2012 datasheet.

The detail information is described in “7. I2C Sensor Interface” of FS2012 Series Datasheet.

Special Notes

None

4.4 RM_FS2012_DataCalculate()

This function calculates flow value [SLPM or SCCM] from ADC data.

Format

```
fsp_err_t RM_FS2012_DataCalculate (
    rm_fsxxxx_ctrl_t      * const p_ctrl,
    rm_fsxxxx_raw_data_t * const p_raw_data,
    rm_fsxxxx_data_t     * const p_fs2012_data
)
```

Parameters

p_ctrl

Pointer to control structure

The members of this structure are shown in 2.9.2(2) Control Struct `rm_fsxxxx_ctrl_t`.

p_raw_data

Pointer to raw data structure for storing the read ADC data from FS2012 sensor

*/** FSXXXX raw data */*

```
typedef struct st_rm_fsxxxx_raw_data
```

```
{
    uint8_t    adc_data[5];
} rm_fsxxxx_raw_data_t;
```

p_fs2012_data

Pointer to FS2012 sensor measurement results data structure

*** FSXXXX data block */*

```
typedef struct st_rm_fsxxxx_data
```

```
{
    rm_fsxxxx_sensor_data_t    flow;
    uint32_t                   count;
} rm_fsxxxx_data_t;
```

The `rm_fsxxxx_sensor_data_t` structure is defined as following.

*/** FSXXXX sensor data block */*

```
typedef struct st_rm_fsxxxx_sensor_data
```

```
{
    int16_t    integer_part;
    int16_t    decimal_part;    ///< To two decimal places
} rm_fsxxxx_sensor_data_t;
```

Return Values

FSP_SUCCESS	Successfully data decoded.
FSP_ERR_ASSERTION	Null pointer, or one or more configuration options is invalid.
FSP_ERR_NOT_OPEN	Module is not open.

Properties

Prototyped in `rm_fs2012.h`

Description

This function calculates the flow value [SLPM or SCCM] from the ADC data stored in "rm_fsxxx_raw_data_t p_raw_data" and stores the calculated results to "rm_fsxxx_data_t p_fs2012_data" structure.

This function calculates the flow value [SLPM or SCCM] from the count value according to the following.

The entire output of the FS2012 is 2 bytes. The flow rate for gas and liquid parts is calculated as follows:

Output Data;

- Number of bytes to read out: 2
- First returned byte: MSB
- Second returned byte: LSB

Gas Part Configurations (FS2012-1020-NG and FS2012-1100-NG);

- Conversion to SLPM (Standard liter er minute)
- Flow in SLPM = [(MSB << 8) + LSB] / 1000

The detail information is described in "8. Calculating Flow Sensor Output" of FS2012 Series Datasheet.

Special Notes

None

4.5 fs2012_user_callback()

This is a callback function registered with Smart Configurator by user.

The default name of callback function for I2C is fs2012_user_callback0, fs2012_user_callback1.

Format

```
void fs2012_user_callback0(rm_fsxxxx_callback_args_t * p_args)
void fs2012_user_callback1(rm_fsxxxx_callback_args_t * p_args)
```

Parameters

p_args

```
/** FSXXXX callback parameter definition */
typedef struct st_rm_fsxxxx_callback_args
{
    void const          * p_context;
    rm_fsxxxx_event_t   event;
} rm_fsxxxx_callback_args_t;
```

Return Values

None

Properties

Prototyped in rm_fs2012_instance.c

Description

None

Special Notes

None

4.6 Usage Example of FS2012 SIS Module

Refer to a sample code included in Application Note “RA Family, RX Family, RL78 Family, RZ Family FS2012 Sample Software Manual (R01AN6047)”.

5. FS3000 API Functions

5.1 RM_FS3000_Open()

This function opens and configures the FS3000 SIS module. This function must be called before calling any other FS3000 API functions.

Format

```
fsp_err_t RM_FS3000_Open (  
    rm_fsxxxx_ctrl_t      * const p_ctrl,  
    rm_fsxxxx_cfg_t const * const p_cfg  
)
```

Parameters

p_ctrl

Pointer to control structure

The members of this structure are shown in 2.9.3(2) Control Struct `rm_fsxxxx_ctrl_t` 2.9.3(2).

p_cfg

Pointer to configuration structure

The members of this structure are shown in 2.9.3(1) Configuration Struct `rm_fsxxxx_cfg_t`.

Return Values

FSP_SUCCESS FS3000 successfully configured.

FSP_ERR_ASSERTION Null pointer, or one or more configuration options is invalid.

FSP_ERR_ALREADY_OPEN Module is already open. This module can only be opened once.

Properties

Prototyped in `rm_fs3000.h`

Description

This function opens and configures the FS3000 SIS module.

This function copies the contents in “`p_cfg`” structure to the member “`p_ctrl->p_cfg`” in “`p_ctrl`” structure.

This function does configurations by setting the members of “`p_ctrl`” structure as following:

- Sets related instance of COMMS SIS module.
- Sets callback and context.
- Sets an open flag.

This function calls an open API of COMMS SIS module to open communication middleware after all above initializations are done.

Special Notes

None

5.2 RM_FS3000_Close()

This function disables specified FS3000 control block.

Format

```
fsp_err_t RM_FS3000_Close (rm_fsxxxx_ctrl_t * const p_ctrl)
```

Parameters

p_ctrl

Pointer to control structure

The members of this structure are shown in 2.9.3(2) Control Struct rm_fsxxxx_ctrl_t.

Return Values

FSP_SUCCESS	Successfully closed.
FSP_ERR_ASSERTION	Null pointer passed as a parameter.
FSP_ERR_NOT_OPEN	Module is not open.

Properties

Prototyped in rm_fs3000.h

Description

This function calls a close API of COMMS SIS module to close communication middleware.

This function clears an open flag after all above are done.

Special Notes

None

5.3 RM_FS3000_Read()

This function reads ADC data from FS3000 sensor.

Format

```
fsp_err_t RM_FS3000_Read (  
    rm_fsxxxx_ctrl_t      * const p_ctrl,  
    rm_fsxxxx_raw_data_t  * const p_raw_data  
)
```

Parameters

p_ctrl

Pointer to control structure

The members of this structure are shown in 2.9.3(2) Control Struct `rm_fsxxxx_ctrl_t`.

p_raw_data

Pointer to raw data structure for storing the read ADC data from FS3000 sensor

*/** FSXXXX raw data */*

```
typedef struct st_rm_fsxxxx_raw_data
```

```
{
```

```
    uint8_t    adc_data[5];
```

```
} rm_fsxxxx_raw_data_t;
```

Return Values

FSP_SUCCESS

Successfully data decoded.

FSP_ERR_ASSERTION

Null pointer, or one or more configuration options is invalid.

FSP_ERR_NOT_OPEN

Module is not open.

Properties

Prototyped in `rm_fs3000.h`

Description

This function reads ADC data from FS3000 sensor.

The read API of COMMS SIS module is called in this function.

The ADC data read from FS3000 sensor is stored in “`p_raw_data`” structure. The read data length is 5 bytes according to FS3000 datasheet.

The detail information is described in “5.2. Digital Output Measurements” of FS3000 Series Datasheet.

Special Notes

None

5.4 RM_FS3000_DataCalculate()

This function calculates air velocity value [m/sec] from ADC data.

Format

```
fsp_err_t RM_FS3000_DataCalculate (
    rm_fsxxxx_ctrl_t      * const p_ctrl,
    rm_fsxxxx_raw_data_t * const p_raw_data,
    rm_fsxxxx_data_t     * const p_fs3000_data
)
```

Parameters

p_ctrl

Pointer to control structure

The members of this structure are shown in 2.9.3(2) Control Struct `rm_fsxxxx_ctrl_t`.

p_raw_data

Pointer to raw data structure for storing the read ADC data from FS3000 sensor

*/** FSXXXX raw data */*

```
typedef struct st_rm_fsxxxx_raw_data
```

```
{
    uint8_t    adc_data[5];
} rm_fsxxxx_raw_data_t;
```

p_fs3000_data

Pointer to FS3000 sensor measurement results data structure

*/** FSXXXX data block */*

```
typedef struct st_rm_fsxxxx_data
```

```
{
    rm_fsxxxx_sensor_data_t    flow;
    uint32_t                   count;
} rm_fsxxxx_data_t;
```

The `fsxxxx_sensor_data_t` structure is defined as following.

*/** FSXXXX sensor data block */*

```
typedef struct st_rm_fsxxxx_sensor_data
```

```
{
    int16_t    integer_part;
    int16_t    decimal_part;    ///< To two decimal places
} rm_fsxxxx_sensor_data_t;
```

Return Values

FSP_SUCCESS	Successfully data decoded.
FSP_ERR_ASSERTION	Null pointer, or one or more configuration options is invalid.
FSP_ERR_NOT_OPEN	Module is not open.
FSP_ERR_SENSOR_INVALID_DATA	Data is invalid.

Properties

Prototyped in `rm_fs3000.h`

Description

This function calculates the air velocity value [m/sec] from the ADC data stored in “`rm_fsxxxx_raw_data_t p_raw_data`” and stores the calculated results to “`rm_fsxxxx_data_t p_fs3000_data`” structure.

This function calculates the air velocity value [m/sec] from the count value.

The relationships between Air velocity and Count value are as follows.

- FS3000-1005

Air Velocity (m/sec)	Output (Count)
0	409
1.07	915
2.01	1522
3.00	2066
3.97	2523
4.96	2908
5.98	3256
6.99	3572
7.23	3686

The detail information is described in "4. Typical Flow Graphs" of FS3000 Series Datasheet.

Special Notes

None

5.5 fs3000_user_callback()

This is a callback function registered with Smart Configurator by user.

The default name of callback function for I2C is fs3000_user_callback0, fs3000_user_callback1.

Format

```
void fs3000_user_callback0(rm_fsxxxx_callback_args_t * p_args)
void fs3000_user_callback1(rm_fsxxxx_callback_args_t * p_args)
```

Parameters

p_args

```
/** FSXXXX callback parameter definition */
typedef struct st_rm_fsxxxx_callback_args
{
    void const          * p_context;
    rm_fsxxxx_event_t   event;
} rm_fsxxxx_callback_args_t;
```

Return Values

None

Properties

Prototyped in rm_fs3000_instance.c

Description

None

Special Notes

None

5.6 Usage Example of FS3000 SIS Module

Refer to a sample code included in Application Note “RA Family, RX Family, RL78 Family, RZ Family FS3000 Sample Software Manual (R01AN5898)”.

6. HS300x API Functions

6.1 RM_HS300X_Open()

This function opens and configures the HS300x SIS module. This function must be called before calling any other HS300x API functions.

Format

```
fsp_err_t RM_HS300X_Open (
    rm_hs300x_ctrl_t * const p_ctrl,
    rm_hs300x_cfg_t const * const p_cfg
)
```

Parameters

p_ctrl

Pointer to control structure.

The members of this structure are shown in 2.9.4(2) Control Struct `rm_hs300x_ctrl_t`.

p_cfg

Pointer to configuration structure

The members of this structure are shown in 2.9.4(1) Configuration Struct `rm_hs300x_cfg_t`.

Return Values

FSP_SUCCESS HS300x successfully configured.

FSP_ERR_ASSERTION Null pointer, or one or more configuration options is invalid.

FSP_ERR_ALREADY_OPEN Module is already open. This module can only be opened once.

Properties

Prototyped in `rm_hs300x.h`

Description

This function opens and configures the HS300x SIS module.

This function copies the contents in “`p_cfg`” structure to the member “`p_ctrl->p_cfg`” in “`p_ctrl`” structure.

This function does configurations by setting the members of “`p_ctrl`” structure as following:

- Sets related instance of COMMS SIS module
- Sets callback and context
- Sets an open flag.

This function calls open API of COMMS SIS module to open communication middleware after all above initializations are done.

Special Notes

None

6.2 RM_HS300X_Close()

This function disables specified HS300x control block.

Format

```
fsp_err_t RM_HS300X_Close (rm_hs300x_ctrl_t * const p_ctrl)
```

Parameters

p_ctrl

Pointer to control structure

The members of this structure are shown in 2.9.4(2) Control Struct rm_hs300x_ctrl_t.

Return Values

FSP_SUCCESS	Successfully closed.
FSP_ERR_ASSERTION	Null pointer passed as a parameter.
FSP_ERR_NOT_OPEN	Module is not open.

Properties

Prototyped in rm_hs300x.h

Description

This function calls close API of COMMS SIS module to close communication middleware.

This function clears open flag after all above are done.

Special Notes

None

6.3 RM_HS300X_MeasurementStart()

This function starts a measurement.

Format

```
fsp_err_t RM_HS300X_MeasurementStart (rm_hs300x_ctrl_t * const p_ctrl)
```

Parameters

p_ctrl

Pointer to control structure

The members of this structure are shown in 2.9.4(2) Control Struct rm_hs300x_ctrl_t.

Return Values

FSP_SUCCESS	Successfully started.
FSP_ERR_ASSERTION	Null pointer passed as a parameter.
FSP_ERR_NOT_OPEN	Module is not open.

Properties

Prototyped in rm_hs300x.h

Description

This function sends the slave address to HS300x sensor and start a measurement.

The function should be called when start a measurement and when measurement data is stale data.

The write API of COMMS SIS module is called in this function to send the slave address to HS300x sensor.

Special Notes

None

6.4 RM_HS300X_Read()

This function reads ADC data from HS300x sensor.

Format

```
fsp_err_t RM_HS300X_Read (
    rm_hs300x_ctrl_t      * const p_ctrl,
    rm_hs300x_raw_data_t * const p_raw_data
)
```

Parameters

p_ctrl

Pointer to control structure

The members of this structure are shown in 2.9.4(2) Control Struct `rm_hs300x_ctrl_t`.

p_raw_data

Pointer to raw data structure for storing the read ADC data from HS300x sensor

*/** HS300X raw data */*

```
typedef struct st_rm_hs300x_raw_data
```

```
{
    uint8_t    humidity[2];    ///< Upper 2 bits of 0th element are data status
    uint8_t    temperature[2]; ///< Lower 2 bits of 1st element are mask
} rm_hs300x_raw_data_t;
```

Return Values

FSP_SUCCESS

Successfully data decoded.

FSP_ERR_ASSERTION

Null pointer, or one or more configuration options are invalid.

FSP_ERR_NOT_OPEN

Module is not open.

Properties

Prototyped in `rm_hs300x.h`

Description

This function reads ADC data from HS300x sensor.

The read API of COMMS SIS module is called in this function.

The ADC data read from HS300x sensor is stored in “`p_raw_data`” structure. The read data length is defined according to GUI configuration setting as 4 bytes (both humidity and temperature) or 2 bytes (humidity only).

Special Notes

None

6.5 RM_HS300X_DataCalculate()

This function calculates humidity [%RH] and temperature [Celsius] from ADC data.

Format

```
fsp_err_t RM_HS300X_DataCalculate (
    rm_hs300x_ctrl_t      * const p_ctrl,
    rm_hs300x_raw_data_t * const p_raw_data,
    rm_hs300x_data_t     * const p_hs300x_data
)
```

Parameters

p_ctrl

Pointer to control structure

The members of this structure are shown in 2.9.4(2) Control Struct `rm_hs300x_ctrl_t`.

p_raw_data

Pointer to raw data structure for storing the read ADC data from HS300x sensor

*/** HS300X raw data */*

```
typedef struct st_rm_hs300x_raw_data
```

```
{
    uint8_t    humidity[2];    ///< Upper 2 bits of 0th element are data status
    uint8_t    temperature[2]; ///< Lower 2 bits of 1st element are mask
} rm_hs300x_raw_data_t;
```

p_hs300x_data

Pointer to HS300x sensor measurement results data structure.

*/** HS300X data block */*

```
typedef struct st_rm_hs300x_data
```

```
{
    rm_hs300x_sensor_data_t    humidity;
    rm_hs300x_sensor_data_t    temperature;
} rm_hs300x_data_t;
```

The `rm_hs300x_sensor_data_t` structure is defined as following.

*/** HS300X sensor data block */*

```
typedef struct st_rm_hs300x_sensor_data
```

```
{
    int16_t    integer_part;
    int16_t    decimal_part;    ///< To two decimal places
} rm_hs300x_sensor_data_t;
```

Return Values

FSP_SUCCESS	Successfully data decoded.
FSP_ERR_ASSERTION	Null pointer, or one or more configuration options is invalid.
FSP_ERR_NOT_OPEN	Module is not open.
FSP_ERR_SENSOR_INVALID_DATA	Data is invalid.

Properties

Prototyped in `rm_hs300x.h`

Description

This function calculates the relative humidity value [%RH] and temperature value in degrees Celsius [°C] from the ADC data stored in “`p_raw_data`” and stores the calculated results to “`p_hs300x_data`” structure.

The status of raw data is shown in the upper 2 bits of `p_raw_data->humidity[0]`. The raw data is invalid (e.g., stale data) if the status bits do not equal “0b00”. This function checks the status calculating. This function will skip calculation if the raw data is invalid.

The calculation method is based on the following formula given in the HS300x Datasheet. The temperature [°C] range is -40 to +125.

$$\text{Humidity [\%RH]} = \left(\frac{\text{Humidity [13:0]}}{2^{14} - 1} \right) * 100$$

$$\text{Temperature [}^{\circ}\text{C]} = \left(\frac{\text{Temperature [15:2]}}{2^{14} - 1} \right) * 165 - 40$$

User application needs to combine the “integer_part” and “decimal_part” of “p_hs300x_data” structure to a float number for humidity and temperature usage.

Special Notes

None

6.6 RM_HS300X_ProgrammingModeEnter()

This function sends commands to place the HS300x into programming mode.

Format

```
fsp_err_t RM_HS300X_ProgrammingModeEnter (rm_hs300x_ctrl_t * const p_ctrl)
```

Parameters

p_ctrl

Pointer to control structure

The members of this structure are shown in 2.9.4(2) Control Struct `rm_hs300x_ctrl_t`.

Return Values

FSP_SUCCESS	Successfully started.
FSP_ERR_ASSERTION	Null pointer passed as a parameter.
FSP_ERR_NOT_OPEN	Module is not open.
FSP_ERR_UNSUPPORTED	Programming mode is not supported.

Properties

Prototyped in `rm_hs300x.h`

Description

This function sends a sequence of commands shown in below figure to place the HS300x into programming mode.

This function must be called within 10ms after applying power to the sensor (HS300x).

Request for measurement data transfer

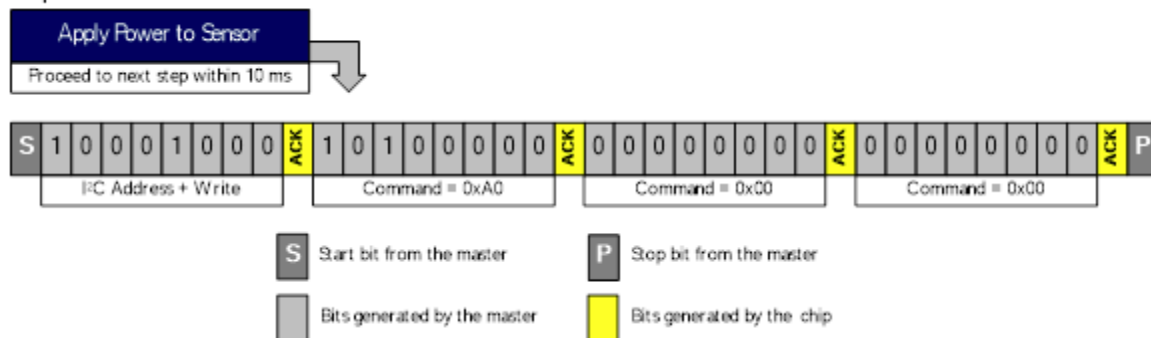

The sequence of commands is that the master must send the I2C address and a “Write” bit followed by the command 0xA0|0x00|0x00. The detail information is described in “6.8 Accessing the Non-volatile Memory” of HS300x Datasheet.

Special Notes

This function must be called within 10ms after applying power to the HS300x sensor.

This function performs for blocking.

6.7 RM_HS300X_ResolutionChange()

This function sends commands to change the HS300x resolution.

Format

```
fsp_err_t RM_HS300X_ResolutionChange (
    rm_hs300x_ctrl_t          * const p_ctrl,
    rm_hs300x_data_type_t    const  data_type,
    rm_hs300x_resolution_t    const  resolution
)
```

Parameters

p_ctrl

Pointer to control structure

The members of this structure are shown in 2.9.4(2) Control Struct `rm_hs300x_ctrl_t`.

data_type

Data type of HS300x.

/** Data type of HS300X */

```
typedef enum e_rm_hs300x_data_type
```

```
{
    RM_HS300X_HUMIDITY_DATA      = 0,
    RM_HS300X_TEMPERATURE_DATA,
} rm_hs300x_data_type_t;
```

resolution

Resolution of HS300x

/** Resolution type of HS300X */

```
typedef enum e_rm_hs300x_resolution
```

```
{
    RM_HS300X_RESOLUTION_8BIT    = 0x00,
    RM_HS300X_RESOLUTION_10BIT   = 0x04,
    RM_HS300X_RESOLUTION_12BIT   = 0x08,
    RM_HS300X_RESOLUTION_14BIT   = 0x0C,
} rm_hs300x_resolution_t;
```

Return Values

FSP_SUCCESS	Successfully started.
FSP_ERR_ASSERTION	Null pointer passed as a parameter.
FSP_ERR_NOT_OPEN	Module is not open.
FSP_ERR_INVALID_MODE	Module is not the programming mode.
FSP_ERR_ABORTED	Communication is aborted.
FSP_ERR_TIMEOUT	Communication is timeout.
FSP_ERR_UNSUPPORTED	Programming mode is not supported.

Properties

Prototyped in `rm_hs300x.h`

Description

This function changes measurement resolutions of the HS300x to 8, 10, 12, or 14-bits by writing to the non-volatile memory. The procedure to change or set the resolution is shown in below figure.

Step 1

Write the register address



Step 2

Read the register contents



Step 3

Change bits [11:10] of the register to the desired resolution setting, *without changing the other bits*

Step 4

Write the register contents back

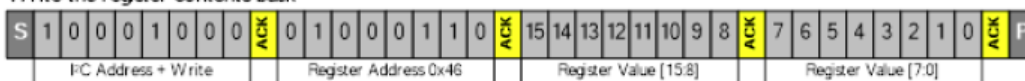

The detail information is described in “6.9 Setting the Measurement Resolution” of HS300x Datasheet.

Special Notes

This function must be called after calling the RM_HS300X_ProgrammingModeEnter function.

This function performs for blocking.

6.8 RM_HS300X_SensorIdGet()

This function obtains the sensor ID of HS300x.

Format

```
fsp_err_t RM_HS300X_SensorIdGet (  
    rm_hs300x_ctrl_t    * const p_ctrl,  
    uint32_t            * const p_sensor_id  
)
```

Parameters

p_ctrl

Pointer to control structure

The members of this structure are shown in 2.9.4(2) Control Struct `rm_hs300x_ctrl_t`.

p_sensor_id

Pointer to Sensor ID

Return Values

FSP_SUCCESS	Successfully started.
FSP_ERR_ASSERTION	Null pointer passed as a parameter.
FSP_ERR_NOT_OPEN	Module is not open.
FSP_ERR_INVALID_MODE	Module is not the programming mode.
FSP_ERR_ABORTED	Communication is aborted.
FSP_ERR_TIMEOUT	Communication is timeout.
FSP_ERR_UNSUPPORTED	Programming mode is not supported.

Properties

Prototyped in `rm_hs300x.h`

Description

This function writes ID registers address 0x1E and 0x1F then reads the ID numbers.

The detail information is described in “6.10 Reading the HS300x ID Number” of HS300x Datasheet.

Special Notes

This function must be called after calling the `RM_HS300X_ProgrammingModeEnter` function.

This function performs for blocking.

6.9 RM_HS300X_ProgrammingModeExit()

This function sends commands to exit the HS300x programming mode.

Format

```
fsp_err_t RM_HS300X_ProgrammingModeExit (rm_hs300x_ctrl_t * const p_ctrl)
```

Parameters

p_ctrl

Pointer to control structure

The members of this structure are shown in 2.9.4(2) Control Struct rm_hs300x_ctrl_t.

Return Values

FSP_SUCCESS	Successfully started.
FSP_ERR_ASSERTION	Null pointer passed as a parameter.
FSP_ERR_NOT_OPEN	Module is not open.
FSP_ERR_INVALID_MODE	Module is not entering the programming mode.
FSP_ERR_UNSUPPORTED	Programming mode is not supported.

Properties

Prototyped in rm_hs300x.h

Description

This function sends the I2C address and a Write bit, followed by the command: 0x80|0x00|0x00 to exit from programming mode, return to normal sensor operation and perform measurements.

The detail information is described in “6.8 Accessing the Non-volatile Memory” of HS300x Datasheet.

Special Notes

This function must be called within 10ms after applying power to the HS300x sensor.

This function performs for blocking.

6.10 hs300x_user_callback()

This is a callback function registered with Smart Configurator by user.

The default name of callback function for I2C is hs300x_user_callback0, hs300x_user_callback1.

Format

```
void hs300x_user_callback0(rm_hs300x_callback_args_t * p_args)
void hs300x_user_callback1(rm_hs300x_callback_args_t * p_args)
```

Parameters

p_args

```
/** HS300X callback parameter definition */
typedef struct st_rm_hs300x_callback_args
{
    void const          * p_context;
    rm_hs300x_event_t   event;
} rm_hs300x_callback_args_t;
```

Return Values

None

Properties

Prototyped in rm_hs300x_instance.c

Description

None

Special Notes

None

6.11 Usage Example of HS300x SIS Module

Refer to a sample code included in Application Note “RA Family, RX Family, RL78 Family, RZ Family HS300x Sample Software Manual (R01AN5897)”.

7. HS400x API Functions

7.1 RM_HS400X_Open()

This function opens and configures the HS400x SIS module. This function must be called before calling any other HS400x API functions.

Format

```
fsp_err_t RM_HS400X_Open (
    rm_hs400x_ctrl_t * const p_ctrl,
    rm_hs400x_cfg_t const *const p_cfg
)
```

Parameters

p_ctrl

Pointer to control structure

The members of this structure are shown in 2.9.5(2) Control Struct `rm_hs400x_ctrl_t`.

p_cfg

Pointer to configuration structure

The members of this structure are shown in 2.9.5(1) Configuration Struct `rm_hs400x_cfg_t`.

Return Values

FSP_SUCCESS	HS400x successfully configured.
FSP_ERR_ASSERTION	Null pointer, or one or more configuration options is invalid.
FSP_ERR_ALREADY_OPEN	Module is already open. This module can only be opened once.
FSP_ERR_TIMEOUT	Communication is timeout.
FSP_ERR_ABORTED	Communication is aborted.

Properties

Prototyped in `rm_hs400x.h`

Description

This function opens and configures the HS400x SIS module.

This function copies the contents in “`p_cfg`” structure to the member “`p_ctrl->p_cfg`” in “`p_ctrl`” structure.

This function does configurations by setting the members of “`p_ctrl`” structure as following:

- Sets related instance of COMMS SIS module.
- Sets callback and context.
- Sets an open flag.

This function calls open API of COMMS SIS module to open communication middleware after all above initializations are done.

Special Notes

None

7.2 RM_HS400X_Close()

This function disables specified HS400x control block.

Format

```
fsp_err_t RM_HS400X_Close (rm_hs400x_ctrl_t * const p_ctrl)
```

Parameters

p_ctrl

Pointer to control structure

The members of this structure are shown in 2.9.5(2) Control Struct rm_hs400x_ctrl_t..

Return Values

FSP_SUCCESS

Successfully closed.

FSP_ERR_ASSERTION

Null pointer passed as a parameter.

FSP_ERR_NOT_OPEN

Module is not open.

Properties

Prototyped in rm_hs400x.h

Description

This function calls close API of COMMS SIS module to close communication middleware.

This function clears open flag after all above are done.

Special Notes

None

7.3 RM_HS400X_MeasurementStart()

This function starts a measurement.

Format

```
fsp_err_t RM_HS400X_MeasurementStart (rm_hs400x_ctrl_t * const p_ctrl)
```

Parameters

p_ctrl

Pointer to control structure

The members of this structure are shown in 2.9.5(2) Control Struct rm_hs400x_ctrl_t.

Return Values

FSP_SUCCESS	Successfully started.
FSP_ERR_ASSERTION	Null pointer passed as a parameter.
FSP_ERR_NOT_OPEN	Module is not open.
FSP_ERR_TIMEOUT	Communication is timeout.
FSP_ERR_ABORTED	Communication is aborted.
FSP_ERR_UNSUPPORTED	Hold measurement is unsupported.

Properties

Prototyped in rm_hs400x.h

Description

This function should be called when start a measurement.

This function sends the command of measurement to HS400X and start a measurement.

This function supports No-Hold measurement and Periodic measurement only.

If Hold measurement is enabled, please call RM_HS400X_Read() without calling this function.

In Periodic measurement, if the periodic measurement has already run, RM_HS400X_EVENT_ERROR is received in callback because HS400x device replies with NACK.

Special Notes

None

7.4 RM_HS400X_MeasurementStop()

This function stops a periodic measurement.

Format

```
fsp_err_t RM_HS400X_MeasurementStop (rm_hs400x_ctrl_t * const p_ctrl)
```

Parameters

p_ctrl

Pointer to control structure

The members of this structure are shown in 2.9.5(2) Control Struct rm_hs400x_ctrl_t.

Return Values

FSP_SUCCESS	Successfully started.
FSP_ERR_ASSERTION	Null pointer passed as a parameter.
FSP_ERR_NOT_OPEN	Module is not open.
FSP_ERR_TIMEOUT	Communication is timeout.
FSP_ERR_ABORTED	Communication is aborted.
FSP_ERR_UNSUPPORTED	Hold and No-Hold measurement are unsupported.

Properties

Prototyped in rm_hs400x.h

Description

This function stops a periodic measurement.

This function sends the command of stopping periodic measurement to HS400X.

This function supports a periodic measurement only.

If a periodic measurement is not running, RM_HS400X_EVENT_ERROR is received in callback because HS400x device replies with NACK.

Special Notes

None

7.5 RM_HS400X_Read()

This function reads ADC data from HS400x sensor.

Format

```
fsp_err_t RM_HS400X_Read (
    rm_hs400x_ctrl_t      * const p_ctrl,
    rm_hs400x_raw_data_t * const p_raw_data
)
```

Parameters

p_ctrl

Pointer to control structure

The members of this structure are shown in 2.9.5(2) Control Struct `rm_hs400x_ctrl_t`.

p_raw_data

Pointer to raw data structure for storing the read ADC data from HS400x sensor

*/** HS400X raw data */*

```
typedef struct st_rm_hs400x_raw_data
```

```
{
    uint8_t    humidity[2];    ///< Upper 2 bits of 0th element are mask
    uint8_t    temperature[2]; ///< Upper 2 bits of 0th element are mask
} rm_hs400x_raw_data_t;
```

Return Values

FSP_SUCCESS	Successfully data decoded.
FSP_ERR_ASSERTION	Null pointer, or one or more configuration options are invalid.
FSP_ERR_NOT_OPEN	Module is not open.
FSP_ERR_TIMEOUT	Communication is timeout.
FSP_ERR_ABORTED	Communication is aborted.

Properties

Prototyped in `rm_hs400x.h`

Description

This function reads ADC data from HS400x sensor.

The read API of COMMS SIS module is called in this function.

The ADC data read from HS400x sensor is stored in “`p_raw_data`” structure. The read data length is defined according to GUI configuration setting as 4 bytes (both humidity and temperature) or 2 bytes (temperature only).

Special Notes

None

7.6 RM_HS400X_DataCalculate()

This function calculates humidity [%RH] and temperature [Celsius] from ADC data.

Format

```
fsp_err_t RM_HS400X_DataCalculate (
    rm_hs400x_ctrl_t      * const p_ctrl,
    rm_hs400x_raw_data_t * const p_raw_data,
    rm_hs400x_data_t     * const p_hs400x_data
)
```

Parameters

p_ctrl

Pointer to control structure

The members of this structure are shown in 2.9.5(2) Control Struct `rm_hs400x_ctrl_t`.

p_raw_data

Pointer to raw data structure for storing the read ADC data from HS400x sensor

*/** HS400X raw data */*

```
typedef struct st_rm_hs400x_raw_data
{
    uint8_t    humidity[2];    ///< Upper 2 bits of 0th element are mask
    uint8_t    temperature[2]; ///< Upper 2 bits of 0th element are mask
} rm_hs400x_raw_data_t;
```

p_hs400x_data

Pointer to HS400x sensor measurement results data structure.

*/** HS400X data block */*

```
typedef struct st_rm_hs400x_data
{
    rm_hs400x_sensor_data_t    humidity;
    rm_hs400x_sensor_data_t    temperature;
} rm_hs400x_data_t;
```

The `rm_hs400x_sensor_data_t` structure is defined as following.

*/** HS400X sensor data block */*

```
typedef struct st_rm_hs400x_sensor_data
{
    int16_t    integer_part;
    int16_t    decimal_part;    ///< To two decimal places
} rm_hs400x_sensor_data_t;
```

Return Values

FSP_SUCCESS	Successfully data decoded.
FSP_ERR_ASSERTION	Null pointer, or one or more configuration options is invalid.
FSP_ERR_NOT_OPEN	Module is not open.
FSP_ERR_SENSOR_INVALID_DATA	Data is invalid.

Properties

Prototyped in `rm_hs400x.h`

Description

This function calculates the relative humidity value [%RH] and temperature value in degrees Celsius [°C] from the ADC data stored in “`p_raw_data`” and stores the calculated results to “`p_hs400x_data`” structure.

The calculation method is based on the following formula given in the HS400x Datasheet. The temperature [°C] range is -40 to +125.

$$\text{Humidity [\%RH]} = \left(\frac{\text{Humidity [13:0]}}{2^{14} - 1} \right) * 100$$

$$\text{Temperature [}^{\circ}\text{C]} = \left(\frac{\text{Temperature [13:0]}}{2^{14} - 1} \right) * 165 - 40$$

User application needs to combine the “integer_part” and “decimal_part” of “p_hs400x_data” structure to a float number for humidity and temperature usage.

Special Notes

None

7.7 hs400x_user_callback()

This is a callback function registered with Smart Configurator by user.

The default name of callback function for I2C is hs400x_user_callback0, hs400x_user_callback1.

Format

```
void hs400x_user_callback0(rm_hs400x_callback_args_t * p_args)
void hs400x_user_callback1(rm_hs400x_callback_args_t * p_args)
```

Parameters

p_args

```
/** HS400X callback parameter definition */
typedef struct st_rm_hs400x_callback_args
{
    void const          * p_context;
    rm_hs400x_event_t   event;
} rm_hs400x_callback_args_t;
```

Return Values

None

Properties

Prototyped in rm_hs400x_instance.c

Description

None

Special Notes

None

7.8 Usage Example of HS400x SIS Module

Refer to a sample code included in Application Note “RA Family, RX Family, RL78 Family, RZ Family HS400x Sample Software Manual (R01AN6333)”.

8. OB1203 API Functions

8.1 RM_OB1203_Open()

This function opens and configures the OB1203 SIS module. This function must be called before calling any other OB1203 API functions.

Format

```
fsp_err_t RM_OB1203_Open (
    rm_ob1203_ctrl_t      * const p_api_ctrl,
    rm_ob1203_cfg_t const * const p_cfg
)
```

Parameters

p_api_ctrl

Pointer to control structure

The members of this structure are shown in 2.9.6(2) Control Struct `rm_ob1203_ctrl_t`.

p_cfg

Pointer to configuration structure

The members of this structure are shown in 2.9.6(1) Configuration Struct `rm_ob1203_cfg_t`.

Return Values

FSP_SUCCESS	Successfully configured.
FSP_ERR_ASSERTION	Null pointer, or one or more configuration options is invalid.
FSP_ERR_ALREADY_OPEN	Module is already open. This module can only be opened once.
FSP_ERR_TIMEOUT	communication is timeout.
FSP_ERR_ABORTED	communication is aborted.

Properties

Prototyped in `rm_ob1203.h`

Description

This function opens and configures the OB1203 SIS module.

This function copies the contents in “`p_cfg`” structure to the member “`p_api_ctrl->p_cfg`” in “`p_api_ctrl`” structure.

This function does configurations by setting the members of “`p_api_ctrl`” structure as following:

- Sets related instance of COMMS SIS module
- Sets parameters of callback and context
- Sets an open flag.

This function calls the following after all above initializations are done.

- Opens API of COMMS SIS module to open communication middleware
- Initializes the sensor device (OB1203)

Special Notes

None

8.2 RM_OB1203_Close()

This function disables specified OB1203 control block. This function should be called when the sensor is closed.

Format

```
fsp_err_t RM_OB1203_Close (rm_ob1203_ctrl_t * const p_api_ctrl)
```

Parameters

p_api_ctrl

Pointer to control structure

The members of this structure are shown in 2.9.6(2) Control Struct `rm_ob1203_ctrl_t`.

Return Values

FSP_SUCCESS	Successfully closed.
FSP_ERR_ASSERTION	Null pointer passed as a parameter.
FSP_ERR_NOT_OPEN	Module is not open.

Properties

Prototyped in `rm_ob1203.h`

Description

This function calls closing API of COMMS SIS module to close communication middleware function.

This function clears open flag after all above are done.

Special Notes

None

8.3 RM_OB1203_MeasurementStart()

This function starts a measurement.

Format

```
fsp_err_t RM_OB1203_MeasurementStart (rm_ob1203_ctrl_t * const p_api_ctrl)
```

Parameters

p_api_ctrl

Pointer to control structure

The members of this structure are shown in 2.9.6(2) Control Struct rm_ob1203_ctrl_t.

Return Values

FSP_SUCCESS	Successfully started.
FSP_ERR_ASSERTION	Null pointer passed as a parameter.
FSP_ERR_NOT_OPEN	Module is not open.

Properties

Prototyped in rm_ob1203.h

Description

This function sends the measurement start to command register of OB1203 sensor and starts a measurement after the "event" in "p_api_ctrl" structure is cleared.

Special Notes

None

8.4 RM_OB1203_MeasurementStop()

This function stops a measurement.

Format

```
fsp_err_t RM_OB1203_MeasurementStop (rm_ob1203_ctrl_t * const p_api_ctrl)
```

Parameters

p_api_ctrl

Pointer to control structure

The members of this structure are shown in 2.9.9(2) Control Struct rm_comms_ctrl_t.

Return Values

FSP_SUCCESS	Successfully data decoded.
FSP_ERR_ASSERTION	Null pointer, or one or more configuration options are invalid.
FSP_ERR_NOT_OPEN	Module is not open.

Properties

Prototyped in rm_ob1203.h

Description

This function sends the measurement stop to command register of OB1203 sensor and stops a measurement.

Special Notes

If device interrupt is enabled, interrupt bits are cleared after measurement stop.
If PPG mode, FIFO information is also reset after measurement stop.

8.5 RM_OB1203_LightRead()

This function reads ADC data of Light from OB1203 device. This function should be called when measurement finished.

Format

```
fsp_err_t RM_OB1203_LightRead (
    rm_ob1203_ctrl_t           * const p_api_ctrl,
    rm_ob1203_raw_data_t      * const p_raw_data,
    rm_ob1203_light_data_type_t type
)
```

Parameters

p_api_ctrl

Pointer to control structure

The members of this structure are shown in 2.9.6(2) Control Struct `rm_ob1203_ctrl_t`.

p_raw_data

Pointer to raw data structure for storing ADC data read from sensor

*/** OB1203 raw data structure */*

```
typedef struct st_rm_ob1203_raw_data
```

```
{
    uint8_t  adc_data[96];    ///< Max of PPG data is 96 (3 bytes multiplied by 32 samples)
} rm_ob1203_raw_data_t;
```

type

Data type enum for Light ADC data

*/** Data type of Light */*

```
typedef enum e_rm_ob1203_light_data_type
```

```
{
    RM_OB1203_LIGHT_DATA_TYPE_ALL           = 0, ///< Common
    RM_OB1203_LIGHT_DATA_TYPE_CLEAR,       ///< Common
    RM_OB1203_LIGHT_DATA_TYPE_GREEN,       ///< Common
    RM_OB1203_LIGHT_DATA_TYPE_BLUE,        ///< CS mode only
    RM_OB1203_LIGHT_DATA_TYPE_RED,         ///< CS mode only
    RM_OB1203_LIGHT_DATA_TYPE_COMP,        ///< Common. Temperature compensation data.
} rm_ob1203_light_data_type_t;
```

Return Values

FSP_SUCCESS	Successfully started.
FSP_ERR_ASSERTION	Null pointer passed as a parameter.
FSP_ERR_NOT_OPEN	Module is not open.

Properties

Prototyped in `rm_ob1203.h`

Description

This function reads ADC data selected by `rm_ob1203_light_data_type_t` and stores data to “`p_raw_data`” structure.

Special Notes

None

8.6 RM_OB1203_LightDataCalculate()

This function calculates light values from ADC data.

Format

```
fsp_err_t RM_OB1203_LightDataCalculate (
    rm_ob1203_ctrl_t * const      p_api_ctrl,
    rm_ob1203_raw_data_t * const p_raw_data,
    rm_ob1203_light_data_t * const p_ob1203_data
)
```

Parameters

p_api_ctrl

Pointer to control structure

The members of this structure are shown in 2.9.6(2) Control Struct `rm_ob1203_ctrl_t`.

p_raw_data

Pointer to raw data structure which ADC data read from sensor is stored in

*/** OB1203 raw data structure */*

```
typedef struct st_rm_ob1203_raw_data
```

```
{
    uint8_t    adc_data[96];    ///< Max of PPG data is 96 (3 bytes multiplied by 32 samples)
} rm_ob1203_raw_data_t;
```

p_ob1203_data

Pointer to calculation result data structure storing Light calculation result

*/** OB1203 light data structure */*

```
typedef struct st_rm_ob1203_light_data
```

```
{
    RM_OB1203_LIGHT_DATA_TYPE_ALL      = 0,    ///< Common
    RM_OB1203_LIGHT_DATA_TYPE_CLEAR,    ///< Common
    RM_OB1203_LIGHT_DATA_TYPE_GREEN,    ///< Common
    RM_OB1203_LIGHT_DATA_TYPE_BLUE,     ///< CS mode only
    RM_OB1203_LIGHT_DATA_TYPE_RED,      ///< CS mode only
    RM_OB1203_LIGHT_DATA_TYPE_COMP,     ///< Common. Temperature compensation data.
} rm_ob1203_light_data_t;
```

Return Values

FSP_SUCCESS	Successfully started.
FSP_ERR_ASSERTION	Null pointer passed as a parameter.
FSP_ERR_NOT_OPEN	Module is not open.

Properties

Prototyped in `rm_ob1203.h`

Description

This function calculates Light results and stores the result into the `rm_ob1203_light_data_t`.

Special Notes

None

8.7 RM_OB1203_ProxRead()

This function reads ADC data of Proximity from OB1203 device. This function should be called when measurement finished.

Format

```
fsp_err_t RM_OB1203_ProxRead (
    rm_ob1203_ctrl_t      * const p_api_ctrl,
    rm_ob1203_raw_data_t * const p_raw_data
)
```

Parameters

p_api_ctrl

Pointer to control structure

The members of this structure are shown in 2.9.6(2) Control Struct `rm_ob1203_ctrl_t`.

p_raw_data

Pointer to raw data structure for storing ADC data read from sensor

*/** OB1203 raw data structure */*

```
typedef struct st_rm_ob1203_raw_data
```

```
{
```

```
    uint8_t    adc_data[96];    ///< Max of PPG data is 96 (3 bytes multiplied by 32 samples)
```

```
} rm_ob1203_raw_data_t;
```

Return Values

FSP_SUCCESS

Successfully started.

FSP_ERR_ASSERTION

Null pointer passed as a parameter.

FSP_ERR_NOT_OPEN

Module is not open.

Properties

Prototyped in `rm_ob1203.h`

Description

This function reads ADC data and stores data to “`p_raw_data`” structure.

Special Notes

None

8.8 RM_OB1203_ProxDDataCalculate()

This function calculates Proximity values from ADC data.

Format

```
fsp_err_t RM_OB1203_ProxDDataCalculate (
    rm_ob1203_ctrl_t * const      p_api_ctrl,
    rm_ob1203_raw_data_t * const p_raw_data,
    rm_ob1203_prox_data_t * const p_ob1203_data
)
```

Parameters

p_api_ctrl

Pointer to control structure

The members of this structure are shown in 2.9.6(2) Control Struct `rm_ob1203_ctrl_t`.

p_raw_data

Pointer to raw data structure which ADC data read from sensor is stored in

*/** OB1203 raw data structure */*

```
typedef struct st_rm_ob1203_raw_data
```

```
{
```

```
    uint8_t    adc_data[96];    ///< Max of PPG data is 96 (3 bytes multiplied by 32 samples)
```

```
} rm_ob1203_raw_data_t;
```

p_ob1203_data

Pointer to calculation result data structure storing Proximity calculation result

*/** OB1203 proximity data structure */*

```
typedef struct st_rm_ob1203_prox_data
```

```
{
```

```
    uint16_t    proximity_data;    ///< Proximity data.
```

```
} rm_ob1203_prox_data_t
```

Return Values

FSP_SUCCESS

Successfully started.

FSP_ERR_ASSERTION

Null pointer passed as a parameter.

FSP_ERR_NOT_OPEN

Module is not open.

Properties

Prototyped in `rm_ob1203.h`

Description

This function calculates Proximity results and stores the results into the `rm_ob1203_prox_data_t`.

Special Notes

None

8.9 RM_OB1203_PpgRead()

This function reads ADC data of PPG from OB1203 sensor. This function should be called when measurement finished.

Format

```
fsp_err_t RM_OB1203_PpgRead (
    rm_ob1203_ctrl_t      * const p_api_ctrl,
    rm_ob1203_raw_data_t * const p_raw_data,
    uint8_t const         number_of_samples
)
```

Parameters

p_api_ctrl

Pointer to control structure

The members of this structure are shown in 2.9.6(2) Control Struct `rm_ob1203_ctrl_t`.

p_raw_data

Pointer to raw data structure for storing ADC data read from sensor

*/** OB1203 raw data structure */*

```
typedef struct st_rm_ob1203_raw_data
```

```
{
    uint8_t    adc_data[96];    ///< Max of PPG data is 96 (3 bytes multiplied by 32 samples)
} rm_ob1203_raw_data_t;
```

number_of_samples

number of PPG samples.

One sample is 3 bytes.

Return Values

FSP_SUCCESS	Successfully started.
FSP_ERR_ASSERTION	Null pointer passed as a parameter.
FSP_ERR_NOT_OPEN	Module is not open.

Properties

Prototyped in `rm_ob1203.h`

Description

This function reads ADC data and stores data to “`p_raw_data`” structure.

Special Notes

None

8.10 RM_OB1203_PpgDataCalculate()

This function calculates PPG values from ADC data.

Format

```
fsp_err_t RM_OB1203_PpgDataCalculate (
    rm_ob1203_ctrl_t      * const p_api_ctrl,
    rm_ob1203_raw_data_t * const p_raw_data,
    rm_ob1203_ppg_data_t * const p_ob1203_data
)
```

Parameters

p_api_ctrl

Pointer to control structure

The members of this structure are shown in 2.9.6(2) Control Struct `rm_ob1203_ctrl_t`.

p_raw_data

Pointer to raw data structure which ADC data read from sensor is stored in

*/** OB1203 raw data structure */*

```
typedef struct st_rm_ob1203_raw_data
```

```
{
    uint8_t    adc_data[96];    ///< Max of PPG data is 96 (3 bytes multiplied by 32 samples)
} rm_ob1203_raw_data_t;
```

p_ob1203_data

Pointer to calculation result data structure storing PPG calculation result

*/** OB1203 PPG data structure */*

```
typedef struct st_rm_ob1203_ppg_data
```

```
{
    uint32_t   ppg_data[32];    ///< PPG data (18bits).
} rm_ob1203_ppg_data_t;
```

Return Values

FSP_SUCCESS	Successfully started.
FSP_ERR_ASSERTION	Null pointer passed as a parameter.
FSP_ERR_NOT_OPEN	Module is not open.

Properties

Prototyped in `rm_ob1203.h`

Description

This function calculates PPG results and stores the results into the `rm_ob1203_ppg_data_t`.

Special Notes

None

8.11 RM_OB1203_DeviceStatusGet()

This function reads the status of sensor.

Format

```
fsp_err_t RM_OB1203_DeviceStatusGet (
    rm_ob1203_ctrl_t          * const p_api_ctrl,
    rm_ob1203_device_status_t * const p_status
)
```

Parameters

p_api_ctrl

Pointer to control structure

The members of this structure are shown in 2.9.6(2) Control Struct rm_ob1203_ctrl_t.

p_status

Pointer to device status

*/** OB1203 device status */*

```
typedef struct st_rm_ob1203_device_status
{
    bool    power_on_reset_occur;
    bool    light_interrupt_occur;
    bool    light_measurement_complete;
    bool    ts_measurement_complete;
    bool    fifo_full_interrupt_occur;    ///< FIFO almost full interrupt
    bool    ppg_measurement_complete;
    bool    object_near;
    bool    prox_interrupt_occur;
    bool    prox_measurement_complete;
} rm_ob1203_device_status_t;
```

Return Values

FSP_SUCCESS	Successfully started.
FSP_ERR_ASSERTION	Null pointer passed as a parameter.
FSP_ERR_NOT_OPEN	Module is not open.
FSP_ERR_TIMEOUT	Communication is timeout.
FSP_ERR_ABORTED	Communication is aborted.

Properties

Prototyped in rm_ob1203.h

Description

This function gets device status from OB1203 device and clears all interrupt bits after read.

Special Notes

None

8.12 RM_OB1203_DeviceInterruptCfgSet()

This function configures device interrupt.

Format

```
fsp_err_t RM_OB1203_DeviceInterruptCfgSet (
    rm_ob1203_ctrl_t          * const p_api_ctrl,
    rm_ob1203_device_interrupt_cfg_t  const interrupt_cfg
)
```

Parameters

p_api_ctrl

Pointer to control structure

The members of this structure are shown in 2.9.6(2) Control Struct rm_ob1203_ctrl_t.

Interrupt_cfg

Device interrupt configuration structure for each operation mode

*/** OB1203 device interrupt configuration structure */*

```
typedef struct st_rm_ob1203_device_interrupt_cfg
```

```
{
```

```
    rm_ob1203_operation_mode_t    light_prox_mode; ///< Light Proximity mode only. If Light mode uses IRQ, set
RM_OB1203_OPERATION_MODE_LIGHT. If Proximity mode uses IRQ, set RM_OB1203_OPERATION_MODE_PROXIMITY.
```

```
    rm_ob1203_light_interrupt_type_t    light_type;        ///< Light mode interrupt type.
```

```
    rm_ob1203_light_interrupt_source_t    light_source;    ///< Light mode interrupt source.
```

```
    rm_ob1203_prox_interrupt_type_t    prox_type;        ///< Proximity mode interrupt type.
```

```
    uint8_t    persist;    ///< The number of similar consecutive Light mode or Proximity interrupt events that must occur
before the interrupt is asserted (4bits).
```

```
    rm_ob1203_ppg_interrupt_type_t    ppg_type;        ///< PPG mode interrupt type.
```

```
} rm_ob1203_device_interrupt_cfg_t;
```

Return Values

FSP_SUCCESS

Successfully started.

FSP_ERR_ASSERTION

Null pointer passed as a parameter.

FSP_ERR_NOT_OPEN

Module is not open.

Properties

Prototyped in rm_ob1203.h

Description

This function configures device interrupts for each operation mode.

Special Notes

None

8.13 RM_OB1203_GainSet()

This function configures gain value.

Format

```
fsp_err_t RM_OB1203_GainSet (
    rm_ob1203_ctrl_t    * const p_api_ctrl,
    rm_ob1203_gain_t    const gain
)
```

Parameters

p_api_ctrl

Pointer to control structure

The members of this structure are shown in 2.9.6(2) Control Struct `rm_ob1203_ctrl_t`.

gain

Gain configuration structure

*/** OB1203 Gain structure */*

```
typedef struct st_rm_ob1203_gain
```

```
{
    rm_ob1203_light_gain_t    light;        ///< Gain for Light mode
    rm_ob1203_ppg_prox_gain_t ppg_prox;    ///< Gain for PPG mode and Proximity mode
} rm_ob1203_gain_t;
```

Return Values

FSP_SUCCESS

Successfully started.

FSP_ERR_ASSERTION

Null pointer passed as a parameter.

FSP_ERR_NOT_OPEN

Module is not open.

Properties

Prototyped in `rm_ob1203.h`

Description

This function configures gain for each operation mode.

Special Notes

None

8.14 RM_OB1203_LedCurrentSet()

This function configures currents for LED.

Format

```
fsp_err_t RM_OB1203_LedCurrentSet (
    rm_ob1203_ctrl_t      * const p_api_ctrl,
    rm_ob1203_led_current_t  const led_current
)
```

Parameters

p_api_ctrl

Pointer to control structure

The members of this structure are shown in 2.9.6(2) Control Struct `rm_ob1203_ctrl_t`.

led_current

Current configuration for LED

*/** OB1203 LED currents structure */*

```
typedef struct st_rm_ob1203_led_current
```

```
{
    uint16_t  ir_led;      ///< IR LED current
    uint16_t  red_led;    ///< Red LED current
} rm_ob1203_led_current_t;
```

Return Values

FSP_SUCCESS	Successfully started.
FSP_ERR_ASSERTION	Null pointer passed as a parameter.
FSP_ERR_NOT_OPEN	Module is not open.

Properties

Prototyped in `rm_ob1203.h`

Description

This function configures LED currents for each operation mode.

Special Notes

None

8.15 RM_OB1203_FifoInfoGet()

This function gets FIFO information (write_index, read_index and overflow_counter).

Format

```
fsp_err_t RM_OB1203_FifoInfoGet (
    rm_ob1203_ctrl_t * const p_api_ctrl,
    rm_ob1203_fifo_info_t * const p_fifo_info
)
```

Parameters

p_api_ctrl

Pointer to control structure

The members of this structure are shown in 2.9.6(2) Control Struct rm_ob1203_ctrl_t.

p_fifo_info

Pointer to FIFO information

*/** OB1203 FIFO information structure */*

```
typedef struct st_rm_ob1203_fifo_info
```

```
{
```

```
    uint8_t    write_index;    ///< The FIFO index where the next sample of PPG data will be written in the FIFO.
```

```
    uint8_t    read_index;    ///< The index of the next sample to be read from the FIFO_DATA register.
```

```
    uint8_t    overflow_counter; ///< If the FIFO Rollover Enable bit is set, the FIFO overflow counter counts the number of old samples (up to 15) which are overwritten by new data.
```

```
    uint8_t    unread_samples; ///< The number of unread samples calculated from the write index and the read index.
```

```
} rm_ob1203_fifo_info_t;
```

Return Values

FSP_SUCCESS

Successfully started.

FSP_ERR_ASSERTION

Null pointer passed as a parameter.

FSP_ERR_NOT_OPEN

Module is not open.

Properties

Prototyped in rm_ob1203.h

Description

This function gets FIFO information for PPG mode. Light and Proximity modes are not supported.

- write_index is the FIFO index where the next sample of PPG data will be written in the FIFO.
- read_index is the index of the next sample to be read from the register.
- overflow_counter is the number of old samples (up to 15) which are overwritten by new data. If the FIFO Rollover is enabled, the FIFO overflow counter counts.
- unread_samples is the number of unread FIFO samples, which can be calculated by write index and read index.

Special Notes

None

8.16 ob1203_user_xxx_callback()

This is a callback function registered with Smart Configurator by user.

The default name of callback function for I2C is ob1203_user_i2c_callback0, ob1203_user_i2c_callback1.

The default name of callback function for IRQ is ob1203_user_irq_callback0, ob1203_user_irq_callback1.

Format

```
void ob1203_user_i2c_callback0(rm_ob1203_callback_args_t * p_args)
void ob1203_user_i2c_callback1(rm_ob1203_callback_args_t * p_args)
void ob1203_user_irq_callback0(rm_ob1203_callback_args_t * p_args)
void ob1203_user_irq_callback1(rm_ob1203_callback_args_t * p_args)
```

Parameters

p_args

```
/** OB1203 callback parameter definition */
typedef struct st_rm_ob1203_callback_args
{
    void const          * p_context;
    rm_ob1203_event_t   event;
} rm_ob1203_callback_args_t;
```

Return Values

None

Properties

Prototyped in rm_ob1203_instance.c

Description

None

Special Notes

None

8.17 Usage Example of OB1203 SIS Module

Refer to a sample code included in Application Note “RA Family, RX Family, RL78 Family OB1203 Sample Software Manual (R01AN6311)”.

9. RRH46410 API Functions

9.1 RM_RRH46410_Open()

This function opens and configures the RRH46410 SIS module. This function must be called before calling any other RRH46410 API functions.

Format

```
fsp_err_t RM_RRH46410_Open (
    rm_zmod4xxx_ctrl_t      * const p_api_ctrl,
    rm_zmod4xxx_cfg_t const * const p_cfg
)
```

Parameters

p_api_ctrl

Pointer to control structure

The members of this structure are shown in 2.9.7(2) Control Struct `rm_zmod4xxx_ctrl_t`.

p_cfg

Pointer to configuration structure

The members of this structure are shown in 2.9.7(1) Configuration Struct `rm_zmod4xxx_cfg_t`.

Return Values

FSP_SUCCESS	RRH46410 successfully configured.
FSP_ERR_ASSERTION	Null pointer, or one or more configuration options is invalid.
FSP_ERR_ALREADY_OPEN	Module is already open. This module can only be opened once.
FSP_ERR_TIMEOUT	Communication is timeout.
FSP_ERR_ABORTED	Communication is aborted.

Properties

Prototyped in `rm_rrh46410.h`

Description

This function opens and initialize the RRH46410 SIS module.

This function copies the contents in “`p_cfg`” structure to the member “`p_api_ctrl->p_cfg`” in “`p_api_ctrl`” structure. This function does configurations by setting the members of “`p_api_ctrl`” structure as following:

- Sets related instance of COMMS SIS module
- Sets related instance of INTC Component
- Sets parameters of callback and context
- Initializes previous sample ID
- Sets warmup counts

This function calls the following after all above initializations are done.

- Opens API of COMMS SIS module to open communication middleware
- Opens API of INTC Component
- Sets the sensor device to Suspend mode
- Sets an open flag.

Special Notes

None

9.2 RM_RRH46410_Close()

This function disables specified RRH46410 control block. This function should be called when the sensor is closed.

Format

```
fsp_err_t RM_RRH46410_Close (rm_zmod4xxx_ctrl_t * const p_api_ctrl)
```

Parameters

p_api_ctrl

Pointer to control structure

The members of this structure are shown in 2.9.7(2) Control Struct `rm_zmod4xxx_ctrl_t`.

Return Values

FSP_SUCCESS	Successfully closed.
FSP_ERR_ASSERTION	Null pointer passed as a parameter.
FSP_ERR_NOT_OPEN	Module is not open.

Properties

Prototyped in `rm_rrh46410.h`

Description

This function calls a close API of COMMS SIS module to close communication middleware and IRQ close function.

This function clears an open flag after all above are done.

Special Notes

None

9.3 RM_RRH46410_MeasurementStart()

This function starts a measurement and should be called when a measurement is started.

Format

```
fsp_err_t RM_RRH46410_MeasurementStart (rm_zmod4xxx_ctrl_t * const p_api_ctrl)
```

Parameters

p_api_ctrl

Pointer to control structure

The members of this structure are shown in 2.9.7(2) Control Struct `rm_zmod4xxx_ctrl_t`.

Return Values

FSP_SUCCESS	Successfully started.
FSP_ERR_ASSERTION	Null pointer passed as a parameter.
FSP_ERR_NOT_OPEN	Module is not opened configured.
FSP_ERR_TIMEOUT	Communication is timeout.
FSP_ERR_ABORTED	Communication is aborted.

Properties

Prototyped in `rm_rrh46410.h`

Description

This function sends the Set Operation Mode command to RRH46410 and shifts to IAQ 2nd Gen, IAQ 2nd Gen ULP or PBAQ mode depending on `RM_RRH46410_CFG_DEVICE0_OPERATION_MODE` in `r_rrh46410_rl_config.h`.

Special Notes

None

9.4 RM_RRH46410_MeasurementStop()

This function stops a measurement and should be called when a measurement is to be stopped.

Format

```
fsp_err_t RM_RRH46410_MeasurementStop (rm_zmod4xxx_ctrl_t * const p_api_ctrl)
```

Parameters

p_api_ctrl

Pointer to control structure

The members of this structure are shown in 2.9.7(2) Control Struct `rm_zmod4xxx_ctrl_t`.

Return Values

FSP_SUCCESS	Successfully stopped.
FSP_ERR_ASSERTION	Null pointer passed as a parameter.
FSP_ERR_NOT_OPEN	Module is not opened configured.
FSP_ERR_TIMEOUT	Communication is timeout.
FSP_ERR_ABORTED	Communication is aborted.

Properties

Prototyped in `rm_rrh46410.h`

Description

This function sends the Set Operation Mode command to RRH46410 and shifts to Suspend mode.

Measurement stops in Suspend mode.

Special Notes

None

9.5 RM_RRH46410_Read()

This function reads measurement data from RRH46410 sensor. This function should be called when measurement finished.

Format

```
fsp_err_t RM_RRH46410_Read (
    rm_zmod4xxx_ctrl_t      * const p_api_ctrl,
    rm_zmod4xxx_raw_data_t * const p_raw_data
)
```

Parameters

p_api_ctrl

Pointer to control structure

The members of this structure are shown in 2.9.7(2) Control Struct `rm_zmod4xxx_ctrl_t`.

p_raw_data

Pointer to raw data structure for storing measurement data read from sensor

*/** ZMOD4XXX raw data structure */*

```
typedef struct st_rm_zmod4xxx_raw_data
```

```
{
```

```
    uint8_t    adc_data[32];    // In RRH46410, this means measurement results
```

```
} rm_zmod4xxx_raw_data_t;
```

Return Values

FSP_SUCCESS

Successfully results are read.

FSP_ERR_ASSERTION

Null pointer passed as a parameter.

FSP_ERR_NOT_OPEN

Module is not opened configured.

FSP_ERR_TIMEOUT

Communication is timeout.

FSP_ERR_ABORTED

Communication is aborted.

Properties

Prototyped in `rm_rrh46410.h`

Description

This function sends the Get Measurement Results command to RRH46410 and gets measurement data.

This function stores measurement results to “`p_raw_data`” structure.

Special Notes

None

9.6 RM_RRH46410_Iaq2ndGenDataCalculate()

This function calculates IAQ 2nd Gen values from the data obtained with RM_RRH46410_Read().

Format

```
fsp_err_t RM_RRH46410_Iaq2ndGenDataCalculate (
    rm_zmod4xxx_ctrl_t          * const p_api_ctrl,
    rm_zmod4xxx_raw_data_t     * const p_raw_data,
    rm_zmod4xxx_iaq_2nd_data_t * const p_rrh46410_data
)
```

Parameters

p_api_ctrl

Pointer to control structure

The members of this structure are shown in 2.9.7(2) Control Struct rm_zmod4xxx_ctrl_t.

p_raw_data

Pointer to raw data structure for storing measurement data read from sensor

*/** ZMOD4XXX raw data structure */*

typedef struct st_rm_zmod4xxx_raw_data

```
{
    uint8_t    adc_data[32];    ///< In RRH46410, this means measurement results
} rm_zmod4xxx_raw_data_t;
```

p_rrh46410_data

Pointer to calculation result data structure storing IAQ 2nd Gen calculation result

*/** ZMOD4XXX IAQ 2nd gen data structure */*

typedef struct st_rm_zmod4xxx_iaq_2nd_data

```
{
    float      rmoX[13];        ///< MOx resistance.
    float      log_rcda;        ///< log10 of CDA resistance for IAQ 2nd Gen.
    float      log_nonlog_rcda[3]; ///< log10 of CDA resistance for IAQ 2nd Gen ULP.
    float      iaq;             ///< IAQ index.
    float      tvoc;            ///< TVOC concentration (mg/m^3).
    float      etoh;            ///< EtOH concentration (ppm).
    float      eco2;            ///< eCO2 concentration (ppm).
    uint8_t    sample_id;       ///< Sample ID. RRH46410 only.
    float      rel_iaq;         ///< Relative IAQ. RRH46410 only.
} rm_zmod4xxx_iaq_2nd_data_t;
```

Return Values

FSP_SUCCESS	Successfully gas data is calculated.
FSP_ERR_ASSERTION	Null pointer passed as a parameter.
FSP_ERR_NOT_OPEN	Module is not opened configured.
FSP_ERR_UNSUPPORTED	Unsupported operation mode.
FSP_ERR_SENSOR_IN_STABILIZATION	Module is in stabilization phase.
FSP_ERR_SENSOR_MEASUREMENT_NOT_FINISHED	Measurement is not finished.

Properties

Prototyped in rm_rrh46410.h

Description

This function calculates IAQ 2nd Gen from "p_raw_data" and stores the results into the "rm_zmod4xxx_iaq_2nd_data_t *p_rrh46410_data" structure.

This function should be called after RM_RRH46410_Read() is called.

Special Notes

None

9.7 RM_RRH46410_PbaqDataCalculate()

This function calculates PBAQ values from the data obtained with RM_RRH46410_Read().

Format

```
fsp_err_t RM_RRH46410_PbaqDataCalculate (
    rm_zmod4xxx_ctrl_t      * const p_api_ctrl,
    rm_zmod4xxx_raw_data_t * const p_raw_data,
    rm_zmod4xxx_pbaq_data_t * const p_rrh46410_data
)
```

Parameters

p_api_ctrl

Pointer to control structure

The members of this structure are shown in 2.9.7(2) Control Struct rm_zmod4xxx_ctrl_t.

p_raw_data

Pointer to raw data structure for storing measurement data read from sensor

*/** ZMOD4XXX raw data structure */*

```
typedef struct st_rm_zmod4xxx_raw_data
```

```
{
    uint8_t    adc_data[32];    // In RRH46410, this means measurement results
} rm_zmod4xxx_raw_data_t;
```

p_zmod4xxx_data

Pointer to calculation result data structure storing PBAQ calculation result

*/** ZMOD4XXX PBAQ data structure */*

```
typedef struct st_rm_zmod4xxx_pbaq_data
```

```
{
    float    rmox[13];        ///< MOx resistance.
    float    log_rcda;        ///< log10 of CDA resistance.
    float    rhtr;            ///< heater resistance.
    float    temperature;     ///< ambient temperature (degC).
    float    tvoc;            ///< TVOC concentration (mg/m^3).
    float    etoh;            ///< EtOH concentration (ppm).
} rm_zmod4xxx_pbaq_data_t;
```

Return Values

FSP_SUCCESS	Successfully gas data is calculated.
FSP_ERR_ASSERTION	Null pointer passed as a parameter.
FSP_ERR_NOT_OPEN	Module is not opened configured.
FSP_ERR_UNSUPPORTED	Unsupported operation mode.
FSP_ERR_SENSOR_IN_STABILIZATION	Module is in stabilization phase.
FSP_ERR_SENSOR_MEASUREMENT_NOT_FINISHED	Measurement is not finished.

Properties

Prototyped in rm_rrh46410.h

Description

This function calculates PBAQ from "p_raw_data" and stores the results into the "rm_zmod4xxx_pbaq_data_t *p_rrh46410_data" structure.

This function should be called after RM_RRH46410_Read() is called.

Special Notes

None

9.8 RM_RRH46410_TemperatureAndHumiditySet()

This function sets relative humidity (in %RH) values to RRH46410 for IAQ 2nd Gen mode and IAQ 2nd Gen ULP mode calculation.

Format

```
fsp_err_t RM_RRH46410_TemperatureAndHumiditySet (  
    rm_zmod4xxx_ctrl_t * const p_api_ctrl,  
    float                temperature,  
    float                humidity  
)
```

Parameters

p_api_ctrl

Pointer to control structure

The members of this structure are shown in 2.9.7(2) Control Struct `rm_zmod4xxx_ctrl_t`.

temperature

Unused

humidity

Humidity value (in %RH) set to RRH46410.

Return Values

FSP_SUCCESS	Successfully humidity is set.
FSP_ERR_ASSERTION	Null pointer passed as a parameter.
FSP_ERR_NOT_OPEN	Module is not opened configured.

Properties

Prototyped in `rm_rrh46410.h`

Description

This function sends the Set Humidity command to RRH46410 and sets environmental relative humidity (in %RH).

This setting provides more accurate data for IAQ 2nd generation measurements.

This function should be called before `RM_RRH46410_Read()` is called.

Special Notes

None

9.9 rrh46410_user_xxx_callback()

This is a callback function registered with Smart Configurator by user.

The default name of callback function for I2C is rrh46410_user_i2c_callback0.

The default name of callback function for IRQ is rrh46410_user_irq_callback0.

Format

```
void rrh46410_user_i2c_callback0(rm_zmod4xxx_callback_args_t * p_args)
```

```
void rrh46410_user_irq_callback0(rm_zmod4xxx_callback_args_t * p_args)
```

Parameters

p_args

```
/** ZMOD4XXX sensor API callback parameter definition */
```

```
typedef struct st_rm_zmod4xxx_callback_args
```

```
{
```

```
    void const                * p_context;
```

```
    rm_zmod4xxx_event_t      event;
```

```
} rm_zmod4xxx_callback_args_t;
```

Return Values

None

Properties

Prototyped in rm_rrh46410_instance.c

Description

None

Special Notes

None

9.10 Usage Example of RRH46410 SIS Module

Refer to a sample code included in Application Note "RA Family, RX Family, RL78 Family RRH46410 Sample Software Manual (R01AN7370)".

10. ZMOD4XXX API Functions

10.1 RM_ZMOD4XXX_Open()

This function opens and configures the ZMOD4XXX SIS module. This function must be called before calling any other ZMOD4XXX API functions.

Format

```
fsp_err_t RM_ZMOD4XXX_Open (
    rm_zmod4xxx_ctrl_t      * const p_api_ctrl,
    rm_zmod4xxx_cfg_t const * const p_cfg
)
```

Parameters

p_api_ctrl

Pointer to control structure

The members of this structure are shown in 2.9.8(2) Control Struct `rm_zmod4xxx_ctrl_t`.

p_cfg

Pointer to configuration structure

The members of this structure are shown in 2.9.8(1) Configuration Struct `rm_zmod4xxx_cfg_t`

Return Values

FSP_SUCCESS	ZMOD4xxx successfully configured.
FSP_ERR_ASSERTION	Null pointer, or one or more configuration options is invalid.
FSP_ERR_ALREADY_OPEN	Module is already open. This module can only be opened once.
FSP_ERR_UNSUPPORTED	Unsupported product ID.
FSP_ERR_TIMEOUT	communication is timeout.
FSP_ERR_ABORTED	communication is aborted.

Properties

Prototyped in `rm_zmod4xxx.h`

Description

This function opens and configures the ZMOD4XXX SIS module.

This function copies the contents in “`p_cfg`” structure to the member “`p_api_ctrl->p_cfg`” in “`p_api_ctrl`” structure.

This function does configurations by setting the members of “`p_api_ctrl`” structure as following:

- Sets related instance of COMMS SIS module.
- Sets ZMOD4XXX library specification.
- Sets parameters of callback and context.
- Sets an open flag.

This function calls the following after all above initializations are done.

- Opens API of COMMS SIS module to open communication middleware.
- Opens API of INTC Component.
- Initializes the sensor device (ZMOD4410 or ZMOD4510).
- Initializes the used sensor library.

Special Notes

None

10.2 RM_ZMOD4XXX_Close()

This function disables specified ZMOD4XXX control block. This function should be called when the sensor is closed.

Format

```
fsp_err_t RM_ZMOD4XXX_Close (rm_zmod4xxx_ctrl_t * const p_api_ctrl)
```

Parameters

p_api_ctrl

Pointer to control structure

The members of this structure are shown in 2.9.8(2) Control Struct `rm_zmod4xxx_ctrl_t`.

Return Values

FSP_SUCCESS	Successfully closed.
FSP_ERR_ASSERTION	Null pointer passed as a parameter.
FSP_ERR_NOT_OPEN	Module is not open.

Properties

Prototyped in `rm_zmod4xxx.h`

Description

This function calls a close API of COMMS SIS module to close communication middleware and IRQ close function.

This function clears an open flag after all above are done.

Special Notes

None

10.3 RM_ZMOD4XXX_MeasurementStart()

This function starts a measurement and should be called when a measurement is started.

Format

```
fsp_err_t RM_ZMOD4XXX_MeasurementStart (rm_zmod4xxx_ctrl_t * const p_api_ctrl)
```

Parameters

p_api_ctrl

Pointer to control structure

The members of this structure are shown in 2.9.8(2) Control Struct `rm_zmod4xxx_ctrl_t`.

Return Values

FSP_SUCCESS	Successfully started.
FSP_ERR_ASSERTION	Null pointer passed as a parameter.
FSP_ERR_NOT_OPEN	Module is not open.
FSP_ERR_TIMEOUT	communication is timeout.
FSP_ERR_ABORTED	communication is aborted.

Properties

Prototyped in `rm_zmod4xxx.h`

Description

This function sends the measurement start to command register of ZMOD4410 or ZMOD4510 sensor and starts a measurement after the “event” in “`p_api_ctrl`” structure is cleared.

Special Notes

When starting the next measurement after previous measurement is finished, a delay time is needed. The delay time is depended on the selected operation mode. The detail information of delay time value can be found in “case DEMO_SEQUENCE_8:” in “`void start_demo(void)`” function described in 10.19 Usage Example of ZMOD4XXX SIS Module.

10.4 RM_ZMOD4XXX_MeasurementStop()

This function stops a measurement and should be called when a measurement is to be stopped.

Format

```
fsp_err_t RM_ZMOD4XXX_MeasurementStop (rm_zmod4xxx_ctrl_t * const p_api_ctrl)
```

Parameters

p_api_ctrl

Pointer to control structure

The members of this structure are shown in 2.9.8(2) Control Struct `rm_zmod4xxx_ctrl_t`.

Return Values

FSP_SUCCESS	Successfully data decoded.
FSP_ERR_ASSERTION	Null pointer, or one or more configuration options are invalid.
FSP_ERR_NOT_OPEN	Module is not open.
FSP_ERR_TIMEOUT	communication is timeout.
FSP_ERR_ABORTED	communication is aborted.

Properties

Prototyped in `rm_zmod4xxx.h`

Description

This function sends the measurement stop to command register of ZMOD4410 or ZMOD4510 sensor and stops a measurement.

Special Notes

None

10.5 RM_ZMOD4XXX_StatusCheck()

This function reads the status of sensor and should be called when polling is used.

Format

```
fsp_err_t RM_ZMOD4XXX_StatusCheck (rm_zmod4xxx_ctrl_t * const p_api_ctrl);
```

Parameters

p_api_ctrl

Pointer to control structure

The members of this structure are shown in 2.9.8(2) Control Struct `rm_zmod4xxx_ctrl_t`.

Return Values

FSP_SUCCESS	Successfully data decoded.
FSP_ERR_ASSERTION	Null pointer, or one or more configuration options is invalid.
FSP_ERR_NOT_OPEN	Module is not open.
FSP_ERR_TIMEOUT	Communication is timeout.
FSP_ERR_ABORTED	Communication is aborted.

Properties

Prototyped in `rm_zmod4xxx.h`

Description

This function reads measurement status of ZMOD4410 and ZMD4510 sensor from sensor register.

This function returns either measurement success or 100ms timeout.

Special Notes

None

10.6 RM_ZMOD4XXX_Read()

This function reads ADC data from ZMOD4410 or ZMOD4510 sensor. This function should be called when measurement finished.

Format

```
fsp_err_t RM_ZMOD4XXX_Read (
    rm_zmod4xxx_ctrl_t      * const p_api_ctrl,
    rm_zmod4xxx_raw_data_t * const p_raw_data
)
```

Parameters

p_api_ctrl

Pointer to control structure

The members of this structure are shown in 2.9.8(2) Control Struct `rm_zmod4xxx_ctrl_t`.

p_raw_data

Pointer to raw data structure for storing ADC data read from sensor

*/** ZMOD4XXX raw data structure */*

```
typedef struct st_rm_zmod4xxx_raw_data
```

```
{
```

```
    uint8_t      adc_data[32];
```

```
} rm_zmod4xxx_raw_data_t;
```

Return Values

FSP_SUCCESS

Successfully started.

FSP_ERR_ASSERTION

Null pointer passed as a parameter.

FSP_ERR_NOT_OPEN

Module is not open.

FSP_ERR_TIMEOUT

Communication is timeout.

FSP_ERR_ABORTED

Communication is aborted.

FSP_ERR_SENSOR_MEASUREMENT_NOT_FINISHED

Measurement is not finished.

Properties

Prototyped in `rm_zmod4xxx.h`

Description

This function checks measurement status by either polling or using busy/interrupt pin. After the measurement status is confirmed as finished, this function reads ADC data and stores data to "p_raw_data" structure.

Special Notes

None

10.7 RM_ZMOD4XXX_Iaq1stGenDataCalculate()

This function calculates IAQ 1st Gen. values from ADC data.

Format

```
fsp_err_t RM_ZMOD4XXX_Iaq1stGenDataCalculate (
    rm_zmod4xxx_ctrl_t          * const p_api_ctrl,
    rm_zmod4xxx_raw_data_t     * const p_raw_data,
    rm_zmod4xxx_iaq_1st_data_t * const p_zmod4xxx_data
)
```

Parameters

p_api_ctrl

Pointer to control structure

The members of this structure are shown in 2.9.8(2) Control Struct `rm_zmod4xxx_ctrl_t`.

p_raw_data

Pointer to raw data structure which ADC data read from sensor is stored in

*/** ZMOD4XXX raw data structure */*

```
typedef struct st_rm_zmod4xxx_raw_data
```

```
{
    uint8_t    adc_data[32];
} rm_zmod4xxx_raw_data_t;
```

p_zmod4xxx_data

Pointer to calculation result data structure storing IAQ 1st Gen. calculation result.

*/** ZMOD4XXX IAQ 1st gen data structure */*

```
typedef struct st_rm_zmod4xxx_iaq_1st_data
{
    float  rmo;           ///< MOx resistance.
    float  rcda;          ///< CDA resistance.
    float  iaq;           ///< IAQ index.
    float  tvoc;          ///< TVOC concentration (mg/m^3).
    float  etoh;          ///< EtOH concentration (ppm).
    float  eco2;          ///< eCO2 concentration (ppm).
} rm_zmod4xxx_iaq_1st_data_t;
```

Return Values

FSP_SUCCESS

Successfully started.

FSP_ERR_ASSERTION

Null pointer passed as a parameter.

FSP_ERR_NOT_OPEN

Module is not open.

FSP_ERR_UNSUPPORTED

Operation mode is not supported.

Properties

Prototyped in `rm_zmod4xxx.h`

Description

This function calculates IAQ results using ZMOD4410 IAQ 1st Gen. library and stores the results into the "rm_zmod4xxx_iaq_1st_data_t *p_zmod4xxx_data" structure.

Special Notes

None

10.8 RM_ZMOD4XXX_Iaq2ndGenDataCalculate()

This function calculates IAQ 2nd Gen. values from ADC data.

Format

```
fsp_err_t RM_ZMOD4XXX_Iaq2ndGenDataCalculate (
    rm_zmod4xxx_ctrl_t          * const p_api_ctrl,
    rm_zmod4xxx_raw_data_t     * const p_raw_data,
    rm_zmod4xxx_iaq_2nd_data_t * const p_zmod4xxx_data
)
```

Parameters

p_api_ctrl

Pointer to control structure

The members of this structure are shown in 2.9.8(2) Control Struct `rm_zmod4xxx_ctrl_t`.

p_raw_data

Pointer to raw data structure which ADC data read from sensor is stored in

*/** ZMOD4XXX raw data structure */*

```
typedef struct st_rm_zmod4xxx_raw_data
```

```
{
    uint8_t    adc_data[32];
} rm_zmod4xxx_raw_data_t;
```

p_zmod4xxx_data

Pointer to calculation result data structure storing IAQ 2nd Gen. calculation result

*/** ZMOD4XXX IAQ 2nd gen data structure */*

```
typedef struct st_rm_zmod4xxx_iaq_2nd_data
```

```
{
    float      rmoX[13];          ///< MOx resistance.
    float      log_rcda;          ///< log10 of CDA resistance for IAQ 2nd Gen.
    float      log_nonlog_rcda[3]; ///< log10 of CDA resistance for IAQ 2nd Gen ULP.
    float      iaq;               ///< IAQ index.
    float      tvoc;              ///< TVOC concentration (mg/m^3).
    float      etoh;              ///< EtOH concentration (ppm).
    float      eco2;              ///< eCO2 concentration (ppm).
} rm_zmod4xxx_iaq_2nd_data_t;
```

Return Values

FSP_SUCCESS	Successfully started.
FSP_ERR_ASSERTION	Null pointer passed as a parameter.
FSP_ERR_NOT_OPEN	Module is not open.
FSP_ERR_UNSUPPORTED	Operation mode is not supported.

Properties

Prototyped in `rm_zmod4xxx.h`

Description

This function calculates IAQ results using ZMOD4410 IAQ 2nd Gen. library and stores the results into the "rm_zmod4xxx_iaq_2nd_data_t *p_zmod4xxx_data" structure.

Special Notes

None

10.9 RM_ZMOD4XXX_OdorDataCalculate()

This function calculates Odor values from ADC data.

Format

```
fsp_err_t RM_ZMOD4XXX_OdorDataCalculate (
    rm_zmod4xxx_ctrl_t          * const p_api_ctrl,
    rm_zmod4xxx_raw_data_t     * const p_raw_data,
    rm_zmod4xxx_odor_data_t    * const p_zmod4xxx_data
)
```

Parameters

p_api_ctrl

Pointer to control structure

The members of this structure are shown in 2.9.8(2) Control Struct `rm_zmod4xxx_ctrl_t`.

p_raw_data

Pointer to raw data structure which ADC data read from sensor is stored in

*/** ZMOD4XXX raw data structure */*

```
typedef struct st_rm_zmod4xxx_raw_data
```

```
{
    uint8_t    adc_data[32];
} rm_zmod4xxx_raw_data_t;
```

p_zmod4xxx_data

Pointer to calculation result data structure storing IAQ 2nd Gen. calculation result

*/** ZMOD4XXX Odor structure */*

```
typedef struct st_rm_zmod4xxx_odor_data
```

```
{
    bool    control_signal;    ///< Control signal input for odor lib.
    float   odor;             ///< Concentration ratio for odor lib.
} rm_zmod4xxx_odor_data_t;
```

Return Values

FSP_SUCCESS	Successfully started.
FSP_ERR_ASSERTION	Null pointer passed as a parameter.
FSP_ERR_NOT_OPEN	Module is not open.
FSP_ERR_UNSUPPORTED	Operation mode is not supported.

Properties

Prototyped in `rm_zmod4xxx.h`

Description

This function calculates Odor results from `r_mox` and odor parameters using ZMOD4410 Odor library and stores the results into the "`rm_zmod4xxx_odor_data_t *p_zmod4xxx_data`" structure.

Special Notes

None

10.10 RM_ZMOD4XXX_SulfurOdorDataCalculate()

This function calculates Sulfur Odor values from ADC data.

Format

```
fsp_err_t RM_ZMOD4XXX_SulfurOdorDataCalculate (
    rm_zmod4xxx_ctrl_t          * const p_api_ctrl,
    rm_zmod4xxx_raw_data_t      * const p_raw_data,
    rm_zmod4xxx_sulfur_odor_data_t * const p_zmod4xxx_data
)
```

Parameters

p_api_ctrl

Pointer to control structure

The members of this structure are shown in 2.9.8(2) Control Struct `rm_zmod4xxx_ctrl_t`.

p_raw_data

Pointer to raw data structure which ADC data read from sensor is stored in

*/** ZMOD4XXX raw data structure */*

typedef struct st_rm_zmod4xxx_raw_data

```
{
    uint8_t    adc_data[32];
} rm_zmod4xxx_raw_data_t;
```

p_zmod4xxx_data

Pointer to calculation result data structure storing Sulfur Odor calculation result

*/** ZMOD4XXX Sulfur-Odor structure */*

typedef struct st_rm_zmod4xxx_sulfur_odor_data

```
{
    float    rmox[9];           ///< MOx resistance.
    float    intensity;        ///< odor intensity rating ranges from 0.0 to 5.0 for sulfur lib
    rm_zmod4xxx_sulfur_odor_t odor;  ///< sulfur_odor classification for lib
} rm_zmod4xxx_sulfur_odor_data_t;
```

Return Values

FSP_SUCCESS

Successfully started.

FSP_ERR_ASSERTION

Null pointer passed as a parameter.

FSP_ERR_NOT_OPEN

Module is not open.

FSP_ERR_UNSUPPORTED

Operation mode is not supported.

Properties

Prototyped in `rm_zmod4xxx.h`

Description

This function calculates Sulfur Odor results from ADC data using ZMOD4410 Sulfur Odor library and stores the results into the “`rm_zmod4xxx_sulfur_odor_data_t *p_zmod4xxx_data`” structure.

Special Notes

None

10.11 RM_ZMOD4XXX_Oaq1stGenDataCalculate()

This function calculates OAQ 1st Gen. values from ADC data.

Format

```
fsp_err_t RM_ZMOD4XXX_Oaq1stGenDataCalculate (
    rm_zmod4xxx_ctrl_t          * const p_api_ctrl,
    rm_zmod4xxx_raw_data_t     * const p_raw_data,
    rm_zmod4xxx_oaq_1st_data_t * const p_zmod4xxx_data
)
```

Parameters

p_api_ctrl

Pointer to control structure

The members of this structure are shown in 2.9.8(2) Control Struct `rm_zmod4xxx_ctrl_t`.

p_raw_data

Pointer to raw data structure which ADC data read from sensor is stored in

*/** ZMOD4XXX raw data structure */*

```
typedef struct st_rm_zmod4xxx_raw_data
```

```
{
    uint8_t    adc_data[32];
} rm_zmod4xxx_raw_data_t;
```

p_zmod4xxx_data

Pointer to calculation result data structure storing OAQ 1st Gen. calculation result

*/** ZMOD4XXX OAQ 1st gen data structure */*

```
typedef struct st_rm_zmod4xxx_oaq_1st_data
{
    float    rmox[15];    ///< MOx resistance
    float    aiq;        ///< Air Quality
} rm_zmod4xxx_oaq_1st_data_t;
```

Return Values

FSP_SUCCESS	Successfully started.
FSP_ERR_ASSERTION	Null pointer passed as a parameter.
FSP_ERR_NOT_OPEN	Module is not open.
FSP_ERR_UNSUPPORTED	Operation mode is not supported.

Properties

Prototyped in `rm_zmod4xxx.h`

Description

This function calculates AQI results from ADC data using ZMOD4510 OAQ 1st Gen. library and stores the results into the "`rm_zmod4xxx_oaq_1st_data_t *p_zmod4xxx_data`" structure.

Special Notes

None

10.12 RM_ZMOD4XXX_Oaq2ndGenDataCalculate()

This function calculates OAQ 2nd Gen. values from ADC data.

Format

```
fsp_err_t RM_ZMOD4XXX_Oaq2ndGenDataCalculate (
    rm_zmod4xxx_ctrl_t          * const p_api_ctrl,
    rm_zmod4xxx_raw_data_t     * const p_raw_data,
    rm_zmod4xxx_oaq_2nd_data_t * const p_zmod4xxx_data
)
```

Parameters

p_api_ctrl

Pointer to control structure

The members of this structure are shown in 2.9.8(2) Control Struct `rm_zmod4xxx_ctrl_t`.

p_raw_data

Pointer to raw data structure which ADC data read from sensor is stored in

*/** ZMOD4XXX raw data structure */*

```
typedef struct st_rm_zmod4xxx_raw_data
```

```
{
    uint8_t    adc_data[32];
} rm_zmod4xxx_raw_data_t;
```

p_zmod4xxx_data

Pointer to calculation result data structure storing OAQ 2nd Gen. calculation result

*/** ZMOD4XXX OAQ 2nd gen data structure */*

```
typedef struct st_rm_zmod4xxx_oaq_2nd_data
```

```
{
    float      rmo_x[8];           ///< MOx resistance.
    float      ozone_concentration; ///< The ozone concentration in part-per-billion
    uint16_t   fast_aqi;          ///< 1-minute average of the Air Quality Index according to the EPA standard based on ozone
    uint16_t   epa_aqi;           ///< The Air Quality Index according to the EPA standard based on ozone
} rm_zmod4xxx_oaq_2nd_data_t;
```

Return Values

FSP_SUCCESS

Successfully started.

FSP_ERR_ASSERTION

Null pointer passed as a parameter.

FSP_ERR_NOT_OPEN

Module is not open.

FSP_ERR_UNSUPPORTED

Operation mode is not supported.

Properties

Prototyped in `rm_zmod4xxx.h`

Description

This function calculates OAQ results from ADC data using ZMOD4510 OAQ 2nd Gen. library and stores the results into the "`rm_zmod4xxx_oaq_2nd_data_t *p_zmod4xxx_data`" structure.

Special Notes

None

10.13 RM_ZMOD4XXX_RaqDataCalculate()

This function calculates RAQ values from ADC data.

Format

```
fsp_err_t RM_ZMOD4XXX_RaqDataCalculate (
    rm_zmod4xxx_ctrl_t      * const p_api_ctrl,
    rm_zmod4xxx_raw_data_t * const p_raw_data,
    rm_zmod4xxx_raq_data_t * const p_zmod4xxx_data
)
```

Parameters

p_api_ctrl

Pointer to control structure

The members of this structure are shown in 2.9.8(2) Control Struct `rm_zmod4xxx_ctrl_t`.

p_raw_data

Pointer to raw data structure which ADC data read from sensor is stored in

*/** ZMOD4XXX raw data structure */*

```
typedef struct st_rm_zmod4xxx_raw_data
```

```
{
    uint8_t    adc_data[32];
} rm_zmod4xxx_raw_data_t;
```

p_zmod4xxx_data

Pointer to calculation result data structure storing RAQ calculation result

*/** ZMOD4XXX RAQ structure */*

```
typedef struct st_rm_zmod4xxx_raq_data
```

```
{
    bool    control_signal;    ///< Control signal input for raq lib.
    float   raq;               ///< Concentration ratio for raq lib.
} rm_zmod4xxx_raq_data_t;
```

Return Values

FSP_SUCCESS

Successfully started.

FSP_ERR_ASSERTION

Null pointer passed as a parameter.

FSP_ERR_NOT_OPEN

Module is not open.

FSP_ERR_UNSUPPORTED

Operation mode is not supported.

Properties

Prototyped in `rm_zmod4xxx.h`

Description

This function calculates RAQ results from `r_mox` and odor parameters using ZMOD4450 RAQ library and stores the results into the "`rm_zmod4xxx_raq_data_t *p_zmod4xxx_data`" structure.

Special Notes

None

10.14 RM_ZMOD4XXX_RellaqDataCalculate()

This function calculates Rel IAQ values from ADC data.

Format

```
fsp_err_t RM_ZMOD4XXX_RellaqDataCalculate (
    rm_zmod4xxx_ctrl_t          * const p_api_ctrl,
    rm_zmod4xxx_raw_data_t     * const p_raw_data,
    rm_zmod4xxx_rel_iaq_data_t * const p_zmod4xxx_data
)
```

Parameters

p_api_ctrl

Pointer to control structure

The members of this structure are shown in 2.9.8(2) Control Struct `rm_zmod4xxx_ctrl_t`.

p_raw_data

Pointer to raw data structure which ADC data read from sensor is stored in

*/** ZMOD4XXX raw data structure */*

```
typedef struct st_rm_zmod4xxx_raw_data
```

```
{
    uint8_t    adc_data[32];
} rm_zmod4xxx_raw_data_t;
```

p_zmod4xxx_data

Pointer to calculation result data structure storing Rel IAQ calculation result

*/** ZMOD4XXX Relative IAQ data structure */*

```
typedef struct st_rm_zmod4xxx_rel_iaq_data
```

```
{
    float    rmox[13];    ///< MOx resistances.
    float    rhtr;        ///< heater resistance.
    float    rel_iaq;     ///< relative IAQ index.
} rm_zmod4xxx_rel_iaq_data_t;
```

Return Values

FSP_SUCCESS

Successfully started.

FSP_ERR_ASSERTION

Null pointer passed as a parameter.

FSP_ERR_NOT_OPEN

Module is not open.

FSP_ERR_UNSUPPORTED

Operation mode is not supported.

Properties

Prototyped in `rm_zmod4xxx.h`

Description

This function calculates IAQ results using ZMOD4410 Rel IAQ library and stores the results into the "rm_zmod4xxx_rel_iaq_data_t *p_zmod4xxx_data" structure.

Special Notes

None

10.15 RM_ZMOD4XXX_PbaqDataCalculate()

This function calculates PBAQ values from ADC data.

Format

```
fsp_err_t RM_ZMOD4XXX_PbaqDataCalculate(
    rm_zmod4xxx_ctrl_t      * const p_api_ctrl,
    rm_zmod4xxx_raw_data_t * const p_raw_data,
    rm_zmod4xxx_pbaq_data_t * const p_zmod4xxx_data
)
```

Parameters

p_api_ctrl

Pointer to control structure

The members of this structure are shown in 2.9.8(2) Control Struct `rm_zmod4xxx_ctrl_t`.

p_raw_data

Pointer to raw data structure which ADC data read from sensor is stored in

*/** ZMOD4XXX raw data structure */*

```
typedef struct st_rm_zmod4xxx_raw_data
```

```
{
    uint8_t    adc_data[32];
} rm_zmod4xxx_raw_data_t;
```

p_zmod4xxx_data

Pointer to calculation result data structure storing PBAQ calculation result

*/** ZMOD4XXX PBAQ data structure */*

```
typedef struct st_rm_zmod4xxx_pbaq_data
```

```
{
    float    rmox[13];        ///< MOx resistance.
    float    log_rcda;        ///< log10 of CDA resistance.
    float    rhtr;           ///< heater resistance.
    float    temperature;     ///< ambient temperature (degC).
    float    tvoc;           ///< TVOC concentration (mg/m^3).
    float    etoh;           ///< EtOH concentration (ppm).
} rm_zmod4xxx_pbaq_data_t;
```

Return Values

FSP_SUCCESS	Successfully started.
FSP_ERR_ASSERTION	Null pointer passed as a parameter.
FSP_ERR_NOT_OPEN	Module is not open.
FSP_ERR_UNSUPPORTED	Operation mode is not supported.

Properties

Prototyped in `rm_zmod4xxx.h`

Description

This function calculates TVOC results using ZMOD4410 PBAQ library and stores the results into the "rm_zmod4xxx_pbaq_data_t *p_zmod4xxx_data" structure.

Special Notes

None

10.16 RM_ZMOD4XXX_TemperatureAndHumiditySet()

This function sets relative humidity (in %RH) and temperature (in °C) values for IAQ 2nd Gen ULP mode and OAQ 2nd Gen calculation.

Format

```
fsp_err_t RM_ZMOD4XXX_TemperatureAndHumiditySet (
    rm_zmod4xxx_ctrl_t * const p_api_ctrl,
    float temperature,
    float humidity
)
```

Parameters

p_api_ctrl

Pointer to control structure

The members of this structure are shown in 2.9.8(2) Control Struct `rm_zmod4xxx_ctrl_t`.

temperature

Temperature value (in °C) set to “`p_api_ctrl -> temperature`”

humidity

Humidity value (in %RH) set to “`p_api_ctrl -> humidity`”

Return Values

FSP_SUCCESS	Successfully started.
FSP_ERR_ASSERTION	Null pointer passed as a parameter.
FSP_ERR_NOT_OPEN	Module is not open.

Properties

Prototyped in `rm_zmod4xxx.h`

Description

In OAQ 2nd Gen operation, an additional temperature and humidity measurement is recommended, and the algorithm has an auto-compensation included.

This function sets environmental relative humidity (in %RH) and temperature (in °C) values for OAQ 2nd Gen calculation.

This function should be called before `RM_ZMOD4XXX_Oaq2ndGenDataCalculate()` is called for calculation.

The detail information is described in “5.5 Environmental Temperature and Humidity” of ZMOD4510 Datasheet.

Special Notes

None

10.17 RM_ZMOD4XXX_DeviceErrorCheck()

This function checks for device errors such as unexpected errors. This function should be called before Read() and DataCalculate().

Format

```
fsp_err_t RM_ZMOD4XXX_DeviceErrorCheck (rm_zmod4xxx_ctrl_t * const p_api_ctrl);
```

Parameters

p_api_ctrl

Pointer to control structure

The members of this structure are shown in 2.9.8(2) Control Struct rm_zmod4xxx_ctrl_t.

Return Values

FSP_SUCCESS	Successfully data decoded.
FSP_ERR_ASSERTION	Null pointer, or one or more configuration options is invalid.
FSP_ERR_NOT_OPEN	Module is not open.
FSP_ERR_TIMEOUT	Communication is timeout.
FSP_ERR_ABORTED	Communication is aborted.

Properties

Prototyped in rm_zmod4xxx.h

Description

This function reads device error status of ZMOD4410 sensor from sensor register. This function returns either measurement success or 100ms timeout. This function is valid for IAQ 2nd Gen, Rel IAQ, and PBAQ.

Special Notes

None

10.18 zmod4xxx_user_xxx_callback()

This is a callback function registered with Smart Configurator by user.

The default name of callback function for I2C is zmod4xxx_user_i2c_callback0, zmod4xxx_user_i2c_callback1.

The default name of callback function for IRQ is zmod4xxx_user_irq_callback0, zmod4xxx_user_irq_callback1.

Format

```
void zmod4xxx_user_i2c_callback0(rm_zmod4xxx_callback_args_t * p_args)
void zmod4xxx_user_i2c_callback1(rm_zmod4xxx_callback_args_t * p_args)
void zmod4xxx_user_irq_callback0(rm_zmod4xxx_callback_args_t * p_args)
void zmod4xxx_user_irq_callback1(rm_zmod4xxx_callback_args_t * p_args)
```

Parameters

p_args

```
/** ZMOD4XXX sensor API callback parameter definition */
typedef struct st_rm_zmod4xxx_callback_args
{
    void const          * p_context;
    rm_zmod4xxx_event_t event;
} rm_zmod4xxx_callback_args_t;
```

Return Values

None

Properties

Prototyped in rm_zmod4xxx_instance.c

Description

None

Special Notes

None

10.19 Usage Example of ZMOD4XXX SIS Module

Refer to a sample code included in Application Note "RA Family, RX Family, RL78 Family ZMOD4xxx Sample Software Manual (R01AN5899)".

11. COMMS API Functions

11.1 RM_COMMS_I2C_Open()

This function opens and configures the COMMS SIS module.

Format

```
fsp_err_t RM_COMMS_I2C_Open (
    rm_comms_ctrl_t      * const p_ctrl,
    rm_comms_cfg_t const * const p_cfg
)
```

Parameters

p_ctrl

Pointer to control structure

The members of this structure are shown in 2.9.9(2) Control Struct `rm_comms_ctrl_t`.

p_cfg

Pointer to configuration structure

The members of this structure are shown in 2.9.9(1) Configuration Struct `rm_comms_cfg_t`.

Return Values

FSP_SUCCESS	Communications Middle module successfully configured.
FSP_ERR_ASSERTION	Null pointer, or one or more configuration options is invalid.
FSP_ERR_ALREADY_OPEN	Module is already open. This module can only be opened once.
FSP_ERR_COMMS_BUS_NOT_OPEN	I2C driver is not open.

Properties

Prototyped in `rm_comms_i2c.h`

Description

This function opens and configures the COMMS SIS module.

This function copies the contents in “`p_cfg`” structure to the member “`p_ctrl->p_cfg`” in “`p_cfg`” structure.

This function does configurations by setting the members of “`p_ctrl`” structure as following:

- Sets bus configuration
- Sets lower-level driver configuration
- Sets callback and context
- Sets an open flag.

Special Notes

None

11.2 RM_COMMS_I2C_Close()

This function disables specified COMMS SIS module.

Format

```
fsp_err_t RM_COMMS_I2C_Close (rm_comms_ctrl_t * const p_ctrl)
```

Parameters

p_ctrl

Pointer to control structure

The members of this structure are shown in 2.9.9(2) Control Struct rm_comms_ctrl_t.

Return Values

FSP_SUCCESS	Communications Middle module successfully configured.
FSP_ERR_ASSERTION	Null pointer, or one or more configuration options is invalid.
FSP_ERR_NOT_OPEN	Module is not open.

Properties

Prototyped in rm_comms_i2c.h

Description

This function clears current device on bus and open flag.

Special Notes

None

11.3 RM_COMMS_I2C_Read()

This function performs a read from I2C device.

Format

```
fsp_err_t RM_COMMS_I2C_Read (
    rm_comms_ctrl_t * const p_ctrl,
    uint8_t * const p_dest,
    uint32_t const bytes
)
```

Parameters

p_ctrl

Pointer to control structure

The members of this structure are shown in 2.9.9(2) Control Struct `rm_comms_ctrl_t`.

p_dest

Pointer to the buffer to store read data

bytes

Number of bytes to read

Return Values

FSP_SUCCESS	Communications Middle module successfully configured.
FSP_ERR_ASSERTION	Null pointer, or one or more configuration options is invalid.
FSP_ERR_NOT_OPEN	Module is not open.
FSP_ERR_IN_USE	Bus is busy.

Properties

Prototyped in `rm_comms_i2c.h`

Description

This function calls internal function “`rm_comms_i2c_bus_read()`” to start read operation from I2C bus which is IICA bus or SAU bus depending on the device (sensor) connection.

The internal function “`rm_comms_i2c_bus_read()`” does bus re-configuration according to contents in “`p_ctrl`”. Then it calls “`R_Config_IICA0_MasterReceive()`” API when the device (sensor) is connected to IICA bus, calls “`R_Config_IIC00_MasterReceive()`” API when the device (sensor) is connected to SAU bus.

The receive pattern of “`R_Config_IICA0_MasterReceive()`” and “`R_Config_IIC00_MasterReceive()`” is set as master reception. In this pattern, the master (RL78 MCU) receives data from the slave.

Please refer to following documents for detail of “`R_Config_IICA0_MasterReceive()`” API and “`R_Config_IIC00_MasterReceive()`” API:

- Smart Configurator User’s Manual: RL78 API Reference (R20UT4852)

Special Notes

None

11.4 RM_COMMS_I2C_Write()

This function performs a write from the I2C device.

Format

```
fsp_err_t RM_COMMS_I2C_Write (
    rm_comms_ctrl_t * const p_ctrl,
    uint8_t * const p_src,
    uint32_t const bytes
)
```

Parameters

p_ctrl

Pointer to control structure

The members of this structure are shown in 2.9.9(2) Control Struct `rm_comms_ctrl_t`.

p_src

Pointer to the buffer to store writing data

bytes

Number of bytes to write

Return Values

FSP_SUCCESS	Communications Middle module successfully configured.
FSP_ERR_ASSERTION	Null pointer, or one or more configuration options is invalid.
FSP_ERR_NOT_OPEN	Module is not open.
FSP_ERR_IN_USE	Bus is busy.

Properties

Prototyped in `rm_comms_i2c.h`

Description

This function calls internal function “`rm_comms_i2c_bus_write()`” to start write operation to I2C bus which is IICA bus or SAU bus depending on device (sensor) connection.

The internal function “`rm_comms_i2c_bus_write()`” does bus re-configuration according to contents in “`p_ctrl`”. Then it calls “`R_Config_IICA0_MasterSend()`” API when the device (sensor) is connected to IICA bus, calls “`R_Config_IIC00_MasterSend()`” API when the device (sensor) is connected to SAU bus.

Please refer to following documents for detail of “`R_Config_IICA0_MasterSend()`” API and “`R_Config_IIC00_MasterSend()`” API:

- Smart Configurator User’s Manual: RL78 API Reference (R20UT4852)

Special Notes

None

11.5 RM_COMMS_I2C_WriteRead()

This function performs a write to, then a read from the I2C device.

Format

```
fsp_err_t RM_COMMS_I2C_WriteRead (
    rm_comms_ctrl_t          * const p_ctrl,
    rm_comms_write_read_params_t  const write_read_params
)
```

Parameters

p_ctrl

Pointer to control structure

The members of this structure are shown in 2.9.9(2) Control Struct `rm_comms_ctrl_t`.

write_read_params

Parameters structure for writeRead API

*/** Struct to pack params for writeRead */*

```
typedef struct st_rm_comms_write_read_params
```

```
{
    uint8_t      * p_src;           ///< pointer to buffer for storing write data
    uint8_t      * p_dest;        ///< pointer to buffer for storing read data
    uint8_t      src_bytes;       ///< number of write data
    uint8_t      dest_bytes;      ///< number of read data
} rm_comms_write_read_params_t;
```

Return Values

FSP_SUCCESS	Communications Middle module successfully configured.
FSP_ERR_ASSERTION	Null pointer, or one or more configuration options is invalid.
FSP_ERR_NOT_OPEN	Module is not open.
FSP_ERR_IN_USE	Bus is busy.

Properties

Prototyped in `rm_comms_i2c.h`

Description

This function calls internal function “`rm_comms_i2c_bus_write_read()`” to start writing to I2C bus, then reading from I2C bus with re-start. The I2C bus is IICA bus or SAU bus depending on device (sensor) connection.

The internal function “`rm_comms_i2c_bus_write_read()`” does bus re-configuration according to contents in “`p_ctrl`”. Then it calls “`R_Config_IICA0_MasterSend()`” API when the device (sensor) is connected to IICA bus, calls “`R_Config_IIC00_MasterSend()`” API when the device (sensor) is connected to SAU bus.

After, in interrupt processing, it calls “`R_Config_IICA0_MasterReceive()`” or “`R_Config_IIC00_MasterReceive()`”.

In this pattern, the master transmits data to the slave. After the transmission completes, a restart condition is generated, and the master receives data from the slave.

Special Notes

None

Revision History

Rev.	Date	Description	
		Page	Summary
1.00	December 9, 2021	-	First Release
1.10	March 20, 2022	15, 16 18 20	Supports the IAQ 2 nd Gen. (Ultra-Low Power) Supports multiple devices on the same bus. Updates the structure of instance control.
1.20	April 27, 2022	-	Add OB1203 sensor
1.30	June 30, 2020	-	Add FS3000 sensor, FS1015 sensor and HS400x sensor
1.40	August 31, 2022	-	Added descriptions of ZMOD4450 to ZMOD4XXX SIS modules
1.41	March 3, 2023	-	Deleted R_ZMOD4XXX_SoftwareDelay Updated test environments
1.50	June 28, 2023	-	Added RM_ZMOD4XXX_RellaqDataCalculate(), RM_ZMOD4XXX_PbaqDataCalculate(), and RM_ZMOD4XXX_DeviceErrorCheck() Updated Usage Example of ZMOD4XXX SIS Module
1.60	Aug 26, 2024	-	Added description of RRH46410 SIS modules Fixed misprint

General Precautions in the Handling of Microprocessing Unit and Microcontroller Unit Products

The following usage notes are applicable to all Microprocessing unit and Microcontroller unit products from Renesas. For detailed usage notes on the products covered by this document, refer to the relevant sections of the document as well as any technical updates that have been issued for the products.

1. Precaution against Electrostatic Discharge (ESD)

A strong electrical field, when exposed to a CMOS device, can cause destruction of the gate oxide and ultimately degrade the device operation. Steps must be taken to stop the generation of static electricity as much as possible, and quickly dissipate it when it occurs. Environmental control must be adequate. When it is dry, a humidifier should be used. This is recommended to avoid using insulators that can easily build up static electricity.

Semiconductor devices must be stored and transported in an anti-static container, static shielding bag or conductive material. All test and measurement tools including work benches and floors must be grounded. The operator must also be grounded using a wrist strap. Semiconductor devices must not be touched with bare hands. Similar precautions must be taken for printed circuit boards with mounted semiconductor devices.

2. Processing at power-on

The state of the product is undefined at the time when power is supplied. The states of internal circuits in the LSI are indeterminate and the states of register settings and pins are undefined at the time when power is supplied. In a finished product where the reset signal is applied to the external reset pin, the states of pins are not guaranteed from the time when power is supplied until the reset process is completed. In a similar way, the states of pins in a product that is reset by an on-chip power-on reset function are not guaranteed from the time when power is supplied until the power reaches the level at which resetting is specified.

3. Input of signal during power-off state

Do not input signals or an I/O pull-up power supply while the device is powered off. The current injection that results from input of such a signal or I/O pull-up power supply may cause malfunction and the abnormal current that passes in the device at this time may cause degradation of internal elements. Follow the guideline for input signal during power-off state as described in your product documentation.

4. Handling of unused pins

Handle unused pins in accordance with the directions given under handling of unused pins in the manual. The input pins of CMOS products are generally in the high-impedance state. In operation with an unused pin in the open-circuit state, extra electromagnetic noise is induced in the vicinity of the LSI, an associated shoot-through current flows internally, and malfunctions occur due to the false recognition of the pin state as an input signal become possible.

5. Clock signals

After applying a reset, only release the reset line after the operating clock signal becomes stable. When switching the clock signal during program execution, wait until the target clock signal is stabilized. When the clock signal is generated with an external resonator or from an external oscillator during a reset, ensure that the reset line is only released after full stabilization of the clock signal. Additionally, when switching to a clock signal produced with an external resonator or by an external oscillator while program execution is in progress, wait until the target clock signal is stable.

6. Voltage application waveform at input pin

Waveform distortion due to input noise or a reflected wave may cause malfunction. If the input of the CMOS device stays in the area between V_{IL} (Max.) and V_{IH} (Min.) due to noise, for example, the device may malfunction. Take care to prevent chattering noise from entering the device when the input level is fixed, and also in the transition period when the input level passes through the area between V_{IL} (Max.) and V_{IH} (Min.).

7. Prohibition of access to reserved addresses

Access to reserved addresses is prohibited. The reserved addresses are provided for possible future expansion of functions. Do not access these addresses as the correct operation of the LSI is not guaranteed.

8. Differences between products

Before changing from one product to another, for example to a product with a different part number, confirm that the change will not lead to problems. The characteristics of a microprocessing unit or microcontroller unit products in the same group but having a different part number might differ in terms of internal memory capacity, layout pattern, and other factors, which can affect the ranges of electrical characteristics, such as characteristic values, operating margins, immunity to noise, and amount of radiated noise. When changing to a product with a different part number, implement a system-evaluation test for the given product.

Notice

1. Descriptions of circuits, software and other related information in this document are provided only to illustrate the operation of semiconductor products and application examples. You are fully responsible for the incorporation or any other use of the circuits, software, and information in the design of your product or system. Renesas Electronics disclaims any and all liability for any losses and damages incurred by you or third parties arising from the use of these circuits, software, or information.
2. Renesas Electronics hereby expressly disclaims any warranties against and liability for infringement or any other claims involving patents, copyrights, or other intellectual property rights of third parties, by or arising from the use of Renesas Electronics products or technical information described in this document, including but not limited to, the product data, drawings, charts, programs, algorithms, and application examples.
3. No license, express, implied or otherwise, is granted hereby under any patents, copyrights or other intellectual property rights of Renesas Electronics or others.
4. You shall be responsible for determining what licenses are required from any third parties, and obtaining such licenses for the lawful import, export, manufacture, sales, utilization, distribution or other disposal of any products incorporating Renesas Electronics products, if required.
5. You shall not alter, modify, copy, or reverse engineer any Renesas Electronics product, whether in whole or in part. Renesas Electronics disclaims any and all liability for any losses or damages incurred by you or third parties arising from such alteration, modification, copying or reverse engineering.
6. Renesas Electronics products are classified according to the following two quality grades: "Standard" and "High Quality". The intended applications for each Renesas Electronics product depends on the product's quality grade, as indicated below.

"Standard": Computers; office equipment; communications equipment; test and measurement equipment; audio and visual equipment; home electronic appliances; machine tools; personal electronic equipment; industrial robots; etc.

"High Quality": Transportation equipment (automobiles, trains, ships, etc.); traffic control (traffic lights); large-scale communication equipment; key financial terminal systems; safety control equipment; etc.

Unless expressly designated as a high reliability product or a product for harsh environments in a Renesas Electronics data sheet or other Renesas Electronics document, Renesas Electronics products are not intended or authorized for use in products or systems that may pose a direct threat to human life or bodily injury (artificial life support devices or systems; surgical implantations; etc.), or may cause serious property damage (space system; undersea repeaters; nuclear power control systems; aircraft control systems; key plant systems; military equipment; etc.). Renesas Electronics disclaims any and all liability for any damages or losses incurred by you or any third parties arising from the use of any Renesas Electronics product that is inconsistent with any Renesas Electronics data sheet, user's manual or other Renesas Electronics document.
7. No semiconductor product is absolutely secure. Notwithstanding any security measures or features that may be implemented in Renesas Electronics hardware or software products, Renesas Electronics shall have absolutely no liability arising out of any vulnerability or security breach, including but not limited to any unauthorized access to or use of a Renesas Electronics product or a system that uses a Renesas Electronics product. RENESAS ELECTRONICS DOES NOT WARRANT OR GUARANTEE THAT RENESAS ELECTRONICS PRODUCTS, OR ANY SYSTEMS CREATED USING RENESAS ELECTRONICS PRODUCTS WILL BE INVULNERABLE OR FREE FROM CORRUPTION, ATTACK, VIRUSES, INTERFERENCE, HACKING, DATA LOSS OR THEFT, OR OTHER SECURITY INTRUSION ("Vulnerability Issues"). RENESAS ELECTRONICS DISCLAIMS ANY AND ALL RESPONSIBILITY OR LIABILITY ARISING FROM OR RELATED TO ANY VULNERABILITY ISSUES. FURTHERMORE, TO THE EXTENT PERMITTED BY APPLICABLE LAW, RENESAS ELECTRONICS DISCLAIMS ANY AND ALL WARRANTIES, EXPRESS OR IMPLIED, WITH RESPECT TO THIS DOCUMENT AND ANY RELATED OR ACCOMPANYING SOFTWARE OR HARDWARE, INCLUDING BUT NOT LIMITED TO THE IMPLIED WARRANTIES OF MERCHANTABILITY, OR FITNESS FOR A PARTICULAR PURPOSE.
8. When using Renesas Electronics products, refer to the latest product information (data sheets, user's manuals, application notes, "General Notes for Handling and Using Semiconductor Devices" in the reliability handbook, etc.), and ensure that usage conditions are within the ranges specified by Renesas Electronics with respect to maximum ratings, operating power supply voltage range, heat dissipation characteristics, installation, etc. Renesas Electronics disclaims any and all liability for any malfunctions, failure or accident arising out of the use of Renesas Electronics products outside of such specified ranges.
9. Although Renesas Electronics endeavors to improve the quality and reliability of Renesas Electronics products, semiconductor products have specific characteristics, such as the occurrence of failure at a certain rate and malfunctions under certain use conditions. Unless designated as a high reliability product or a product for harsh environments in a Renesas Electronics data sheet or other Renesas Electronics document, Renesas Electronics products are not subject to radiation resistance design. You are responsible for implementing safety measures to guard against the possibility of bodily injury, injury or damage caused by fire, and/or danger to the public in the event of a failure or malfunction of Renesas Electronics products, such as safety design for hardware and software, including but not limited to redundancy, fire control and malfunction prevention, appropriate treatment for aging degradation or any other appropriate measures. Because the evaluation of microcomputer software alone is very difficult and impractical, you are responsible for evaluating the safety of the final products or systems manufactured by you.
10. Please contact a Renesas Electronics sales office for details as to environmental matters such as the environmental compatibility of each Renesas Electronics product. You are responsible for carefully and sufficiently investigating applicable laws and regulations that regulate the inclusion or use of controlled substances, including without limitation, the EU RoHS Directive, and using Renesas Electronics products in compliance with all these applicable laws and regulations. Renesas Electronics disclaims any and all liability for damages or losses occurring as a result of your noncompliance with applicable laws and regulations.
11. Renesas Electronics products and technologies shall not be used for or incorporated into any products or systems whose manufacture, use, or sale is prohibited under any applicable domestic or foreign laws or regulations. You shall comply with any applicable export control laws and regulations promulgated and administered by the governments of any countries asserting jurisdiction over the parties or transactions.
12. It is the responsibility of the buyer or distributor of Renesas Electronics products, or any other party who distributes, disposes of, or otherwise sells or transfers the product to a third party, to notify such third party in advance of the contents and conditions set forth in this document.
13. This document shall not be reprinted, reproduced or duplicated in any form, in whole or in part, without prior written consent of Renesas Electronics.
14. Please contact a Renesas Electronics sales office if you have any questions regarding the information contained in this document or Renesas Electronics products.

(Note1) "Renesas Electronics" as used in this document means Renesas Electronics Corporation and also includes its directly or indirectly controlled subsidiaries.

(Note2) "Renesas Electronics product(s)" means any product developed or manufactured by or for Renesas Electronics.

(Rev.5.0-1 October 2020)

Corporate Headquarters

TOYOSU FORESIA, 3-2-24 Toyosu,
Koto-ku, Tokyo 135-0061, Japan
www.renesas.com

Trademarks

Renesas and the Renesas logo are trademarks of Renesas Electronics Corporation. All trademarks and registered trademarks are the property of their respective owners.

Contact information

For further information on a product, technology, the most up-to-date version of a document, or your nearest sales office, please visit:
www.renesas.com/contact/.