

RTKA215300DE0000BU

The RTKA215300DE0000BU evaluation board (EVB) is a platform for evaluating the functionality and performance of the RAA215300 PMIC. There is access to regulator switching voltages, inductor currents, input currents, control loops, and more. The user can change many operating characteristics using an I<sup>2</sup>C interface.

**Specifications**

Requiring only the addition of inductors and capacitors, RAA215300 integrates all semiconductors and control circuitry to create a complete power solution for systems that use Renesas RZ/G2L microprocessors. The EVB can easily be configured to meet the requirements of many other applications.

**Features**

- A complete power supply system
- Access to all RAA215300 features
- Facility to adjust RAA215300 settings
- Flexibility to create many different power systems
- Connectivity to the whole power system
- Access for monitoring and test
- Access for design modification

**Evaluation Board Contents**

- EVB PCB assembly
- Mini USB I<sup>2</sup>C dongle with USB cable (ISLUSBMINIEVAL1Z)

CONFIDENTIAL

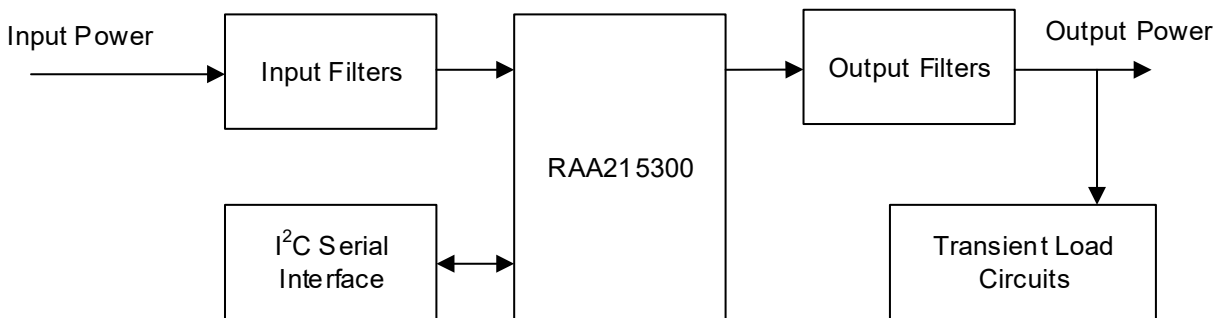

Figure 1. EVB Block Diagram

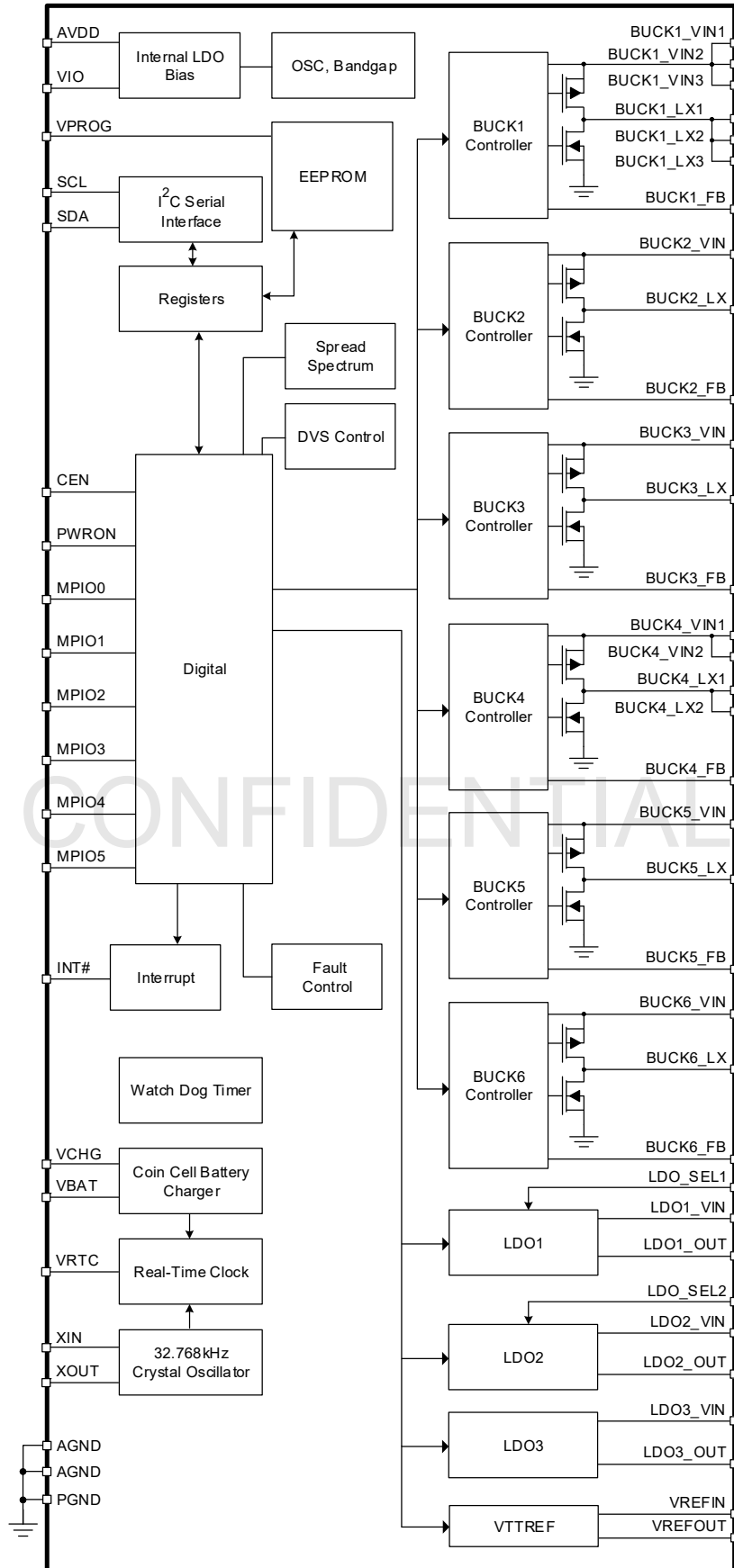

Figure 2. PMIC Block Diagram

## Contents

<b>1. Reference Material</b> .....	<b>4</b>
<b>2. Functional Description</b> .....	<b>4</b>
2.1 Overview .....	4
2.2 Operating Characteristics .....	5
2.2.1 Operating Limits .....	5
2.2.2 Default Operation .....	5
2.3 Setup and Configuration .....	6
2.3.1 Signal List and Access .....	6
2.3.2 Recommended Equipment .....	7
2.3.3 Initial State of Jumpers and Switches .....	7
2.3.4 Evaluation Software and GUI .....	8
2.3.5 Operating Procedure .....	8
2.3.6 Transient Load Circuits .....	12
<b>3. Board Design</b> .....	<b>15</b>
3.1 Layout Guidelines .....	16
3.2 Schematic Diagram .....	17
3.3 Bill of Materials .....	22
3.4 Board Layout .....	22
<b>4. Ordering Information</b> .....	<b>25</b>
<b>5. Revision History</b> .....	<b>25</b>

CONFIDENTIAL

## 1. Reference Material

For reference material, including the datasheet and evaluation software, visit the [RAA215300](#) product page on the Renesas website.

## 2. Functional Description

### 2.1 Overview

- Operating input voltage range: 2.7V to 5.5V
- Six synchronous buck regulators (5A, 3.5A, 1.5A, 1.5A,  $\pm 1$ A, 0.6A), with settable output voltage
- Three LDOs (300mA, 300mA, 50mA), with bypass mode and settable output voltage
- Integral EEPROM for system settings
- Programmable settings and configuration using an I<sup>2</sup>C interface
- I<sup>2</sup>C serial interface (up to 1MHz, with SCL and SDA pull-up resistors on dongle changed to 1k $\Omega$ )
- Onboard transient load circuits
- Internal MOSFETs
- Internally compensated control loops
- Power sequencing control
- Dedicated VTTREF for DDR memory
- Auto PFM/PWM, FPWM
- Selectable switching frequency
- Ultrasonic switching mode
- Spread spectrum switching mode
- Phase synchronization
- Sleep Mode
- Dynamic voltage scaling
- 32kHz crystal oscillator, RTC, charger for battery or supercapacitor

The EVB has a dongle to facilitate an I<sup>2</sup>C interface, which is used to adjust PMIC settings and communicate status. The I<sup>2</sup>C interface can be controlled by a dedicated Renesas proprietary Graphical User Interface (GUI), which requires a host computer.

The EVB includes switches and jumpers to emulate the signal interface (some of which are configurable MPIO) with a microprocessor-based system.

The PMIC can be connected to the onboard I<sup>2</sup>C interface dongle or to onboard pull-up and pull-down switches. For each signal, there is a straight 3-way header on the PCB. The middle pin is connected to the PMIC; one outer pin is connected to the dongle; the other outer pin is connected to a switch. A jumper connects the middle pin to either of the two outer pins and thereby selects the source of the signal. The switch position selects pull-up or pull-down.

## 2.2 Operating Characteristics

### 2.2.1 Operating Limits

The EVB can operate across the full ranges for voltage, current, and temperature described in the datasheet. Each regulator can be loaded to its full electrical rating but PMIC thermal ratings must be respected, so the combined load on all regulators is limited by PMIC dissipation, PCB design, and thermal environment.

### 2.2.2 Default Operation

As delivered, capacitors, inductors, and PMIC settings of the EVB have been selected primarily to demonstrate the performance required by an RZ/G2L microprocessor system with a 5V input. Brief output specifications are shown in [Table 1](#). However, all settings described in the Register Map Detail section of the datasheet can be changed using the I<sup>2</sup>C interface, so other power systems can be created. The input voltage must be greater than each output voltage. No damage is caused by experimenting with settings, but it would require significant knowledge of the PMIC to optimize a power system.

**Table 1. EVB Output Power Specification**

Regulator	Output voltage (V)	Output current (A)
BUCK1	1.1	5
BUCK2	1.2	1.5
BUCK3	1.8	1.5
BUCK4	3.3	3.5
BUCK5	1.2	0.6
BUCK6	0.6	+/-1
LDO1	3.3	0.3
LDO2	3.3	0.3
LDO3	2.5	0.05

## 2.3 Setup and Configuration

### 2.3.1 Signal List and Access

The signal list, switch identification, and jumper identification are shown in [Table 2](#)

**Table 2. Signal Interface List**

Signal Name	Switch Identifier	Jumper Identifier	Description
CEN	SW_CEN	JP_CEN	Chip enable.
PWRON	SW_PWRON	JP_PWRON	Regulator output enable.
VPULLUP	Not applicable	JP_VPULLUP	Select pull-up voltage for digital signals.
VPROG	SW_VPROG	Not applicable	 See warning in <a href="#">Power Supplies</a> . 21V to 23V power supply, only required when programming the EEPROM.
LDO_SEL1	SW_LDOSEL1	JP_LDOSEL1	Enables LDO1 output voltage to be changed during active state.
LDO_SEL2	SW_LDOSEL2	JP_LDOSEL2	Enables LDO2 output voltage to be changed during active state.
INT#		JP_INT#	Interrupt output, fault alarm.
MPIOx	SW_MPIOx	JP_MPIOx	x represents numbers 0 to 5. See the datasheet for functions.
BUCKx_FB		JP_RFBx	x represents numbers 1 to 6. The jumper can be used to open the feedback loop to enable gain measurement, or to enable remote sensing if the load is some distance from the EVB.
VRTC		JP_VRTC	Connects extra capacitance to RTC power supply.
VREFIN		JP_VREFIN	Connects buck2 output to VREFIN.
VCHG		JP_VCHG	Connects VCHG to VIN.
VBAT		JP_VBAT	Connects VBAT output to optional supercapacitor.
SDA_HV		JP_SDA	Connects I <sup>2</sup> C serial data line to the dongle.
SCL_HV		JP_SCL	Connects I <sup>2</sup> C serial clock line to the dongle.
+IN1		JP_+IN1	Redundant. Leave open.
+IN2		JP_+IN2	Redundant. Leave open.
-SUPPLY		JP_-SUPPLY	Configures transient load circuit.
Not applicable		JP_IO2	Configures transient load circuit.
Not applicable		JP_IOP	Configures transient load circuit.
Not applicable		JP_ION	Configures transient load circuit.

### 2.3.2 Recommended Equipment

- Bench power supply: 0 to 5.5V; 0 to 10A
- Digital storage oscilloscope (DSO): 4 channels; 100MHz bandwidth
- Multiple loads: adjustable electronic loads and/or resistive loads
- Multiple voltmeters and ammeters
- Signal generator (to drive the transient load circuits)
- Multiple cables with 4mm banana plugs for connection to the EVB
- Soldering iron

### 2.3.3 Initial State of Jumpers and Switches

- See Figure 3. Set all the switch positions as shown by red arrows.
- Set the jumpers as shown by red rectangles. Do not place any jumpers not shown.
- Connect the interface board to the computer with the USB cable.

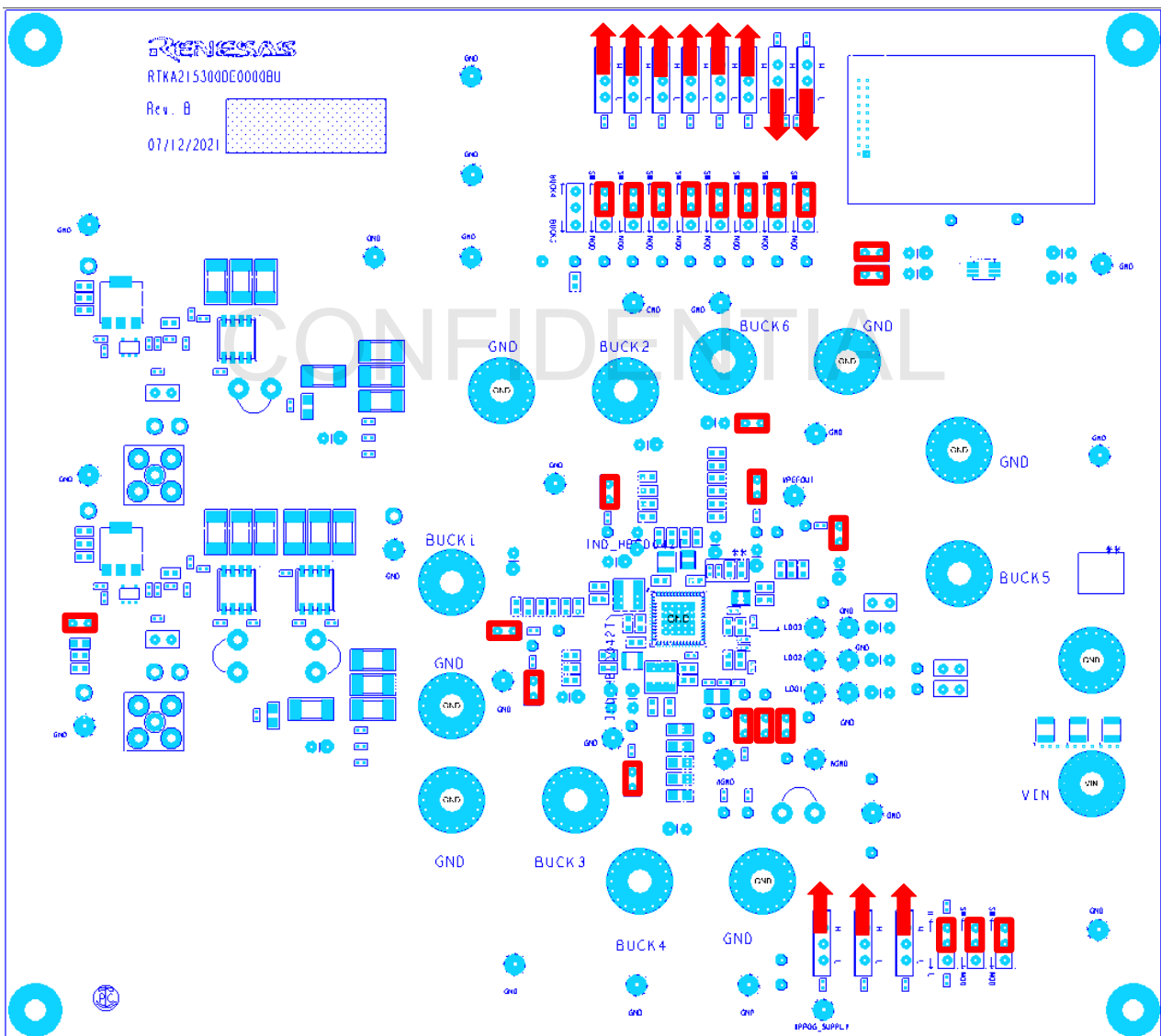

Figure 3. Default State of Switches and Jumpers

### 2.3.4 Evaluation Software and GUI

The EVB operates without running the RAA215300 evaluation software. For enhanced access and adjustability, the RAA215300 evaluation software and its user guide are available for download from the [RAA215300](#) product page.

1. Save the software file and install the software by double clicking on the file name and following the on-screen instructions.
2. Attach the USB I<sup>2</sup>C interface dongle to the computer using the supplied USB cable.
3. Run the RAA215300 evaluation software.

The GUI provides read and write access to the registers. The GUI is organized into sections for each regulator, fault management, MPIO, global configuration, and RTC. Each section provides values and simple descriptions of settings. Drop-down lists show the setting options and facilitate changes to those settings.

### 2.3.5 Operating Procedure

The following operating procedure does not require the RAA215300 evaluation software.

#### 2.3.5.1 Power Supplies



**WARNING!** Do not hot-swap: Connecting or disconnecting a device to or from a powered-up circuit can cause damage to the device. All power supplies used for operating the device must be powered down and their outputs discharged before adding or removing a device to or from a circuit, including but not limited to: a test socket, a test harness, or a test jig.

Fast connection or fast disconnection of the power supply to VPROG\_SUPPLY can damage the EVB.

The external, current limited power supply must be increased from 0V to between 21V and 23V in no less than 1ms.

The external, current limited power supply must be decreased from between 21V and 23V to 0V in no less than 1ms.

The VPROG switch on the EVB must not be closed while the external power supply is connected and at a voltage greater than 0V.

See [Figure 4](#).

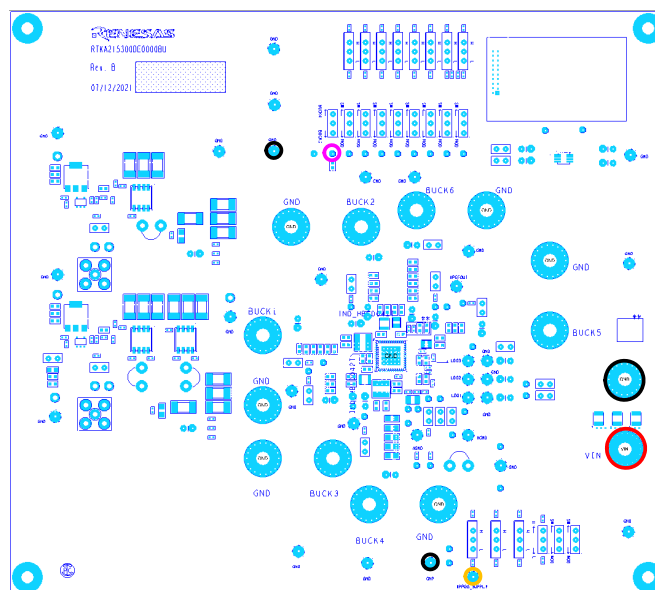

Figure 4. Power Supply Connections



1. Connect a power supply to VIN (red) and GND (black) 4mm banana sockets, with the voltage set to 5.0V (OFF).
2. Connect a power supply to VPULLUP yellow post (magenta), and GND post (black), with the voltage set to 1.8V (OFF).
3. Only if writing to EEPROM, apply a power supply to the VPROG\_SUPPLY post (circled in orange) and GND post (black), with the power supply off or set to 0V. Leave open if not used.
4. As an initial precaution, set current limits on the power supplies. For example:
  - VIN: 500mA
  - VPULLUP: 100mA
  - VPROG\_SUPPLY: 100mA
5. Apply the power supplies in any sequence.

**2.3.5.2 Power Up Procedure**

1. Switch CEN on (see the green arrow in Figure 5).

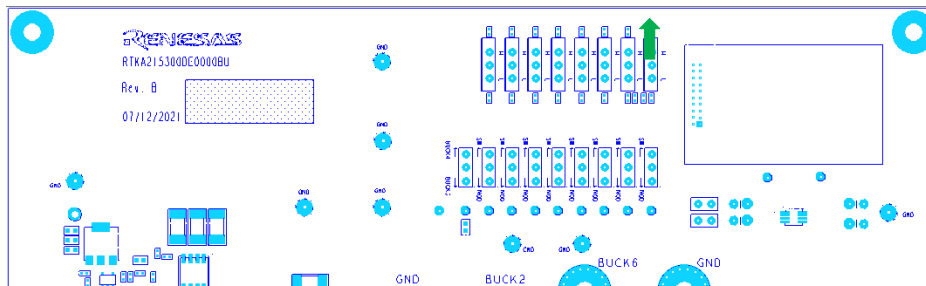

Figure 5. CEN Switch

2. Switch PWRON on (see the orange arrow in Figure 6) to enable the regulators. Regulator output voltages are established in the sequence set in the relevant registers.

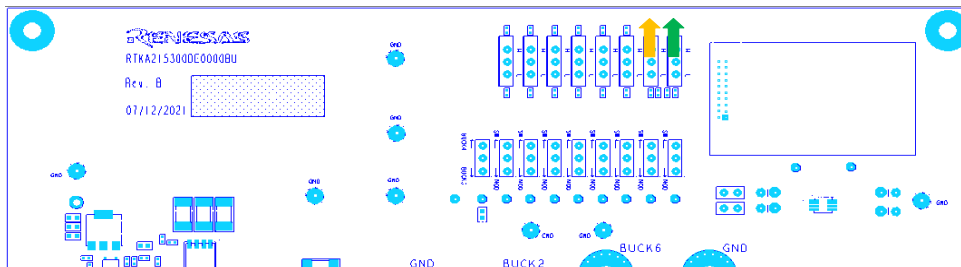
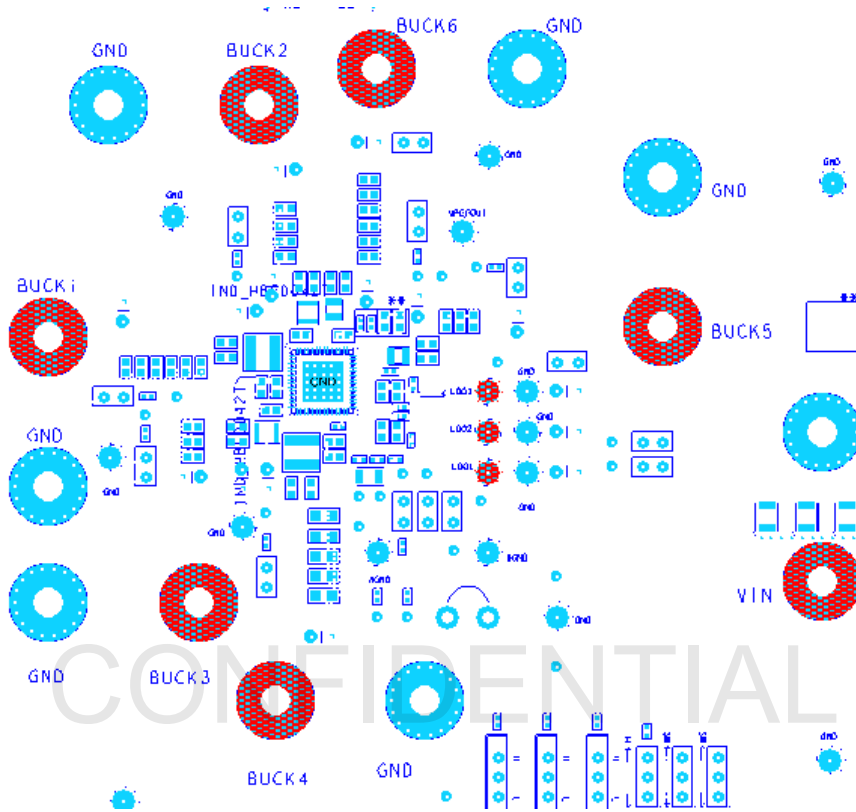

Figure 6. PWRON Switch

**2.3.5.3 Loading the Regulators**

1. Before applying load to the regulator outputs, increase the current limit on the input (VIN) supply to a level that supports VIN voltage when loads are applied.
2. Connect loads to the buck regulator outputs at the 4mm banana sockets shown in Figure 7. The ground of each output is the black socket adjacent to its respective red socket. The sockets include screw-down connections that can be used for connecting electronic load remote sensing.



**Figure 7. Regulator Load Connection Points**

3. Connect loads to the LDO regulator outputs at the pins shown in Figure 8.

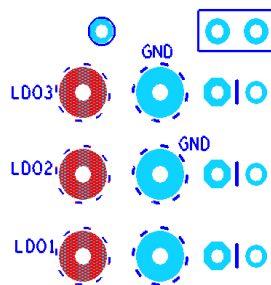

**Figure 8. LDO Regulator Load Connection Points**

2.3.5.4 Monitoring Regulator Output Voltages

- Figure 9 shows locations on the PCB where the buck regulator output voltages can be measured accurately. For each buck regulator, there is a pair of pads with holes to which wires, pins, or connectors can be soldered, or an oscilloscope probe can be connected. The larger of each pair of pads is the positive; the smaller pad is ground.

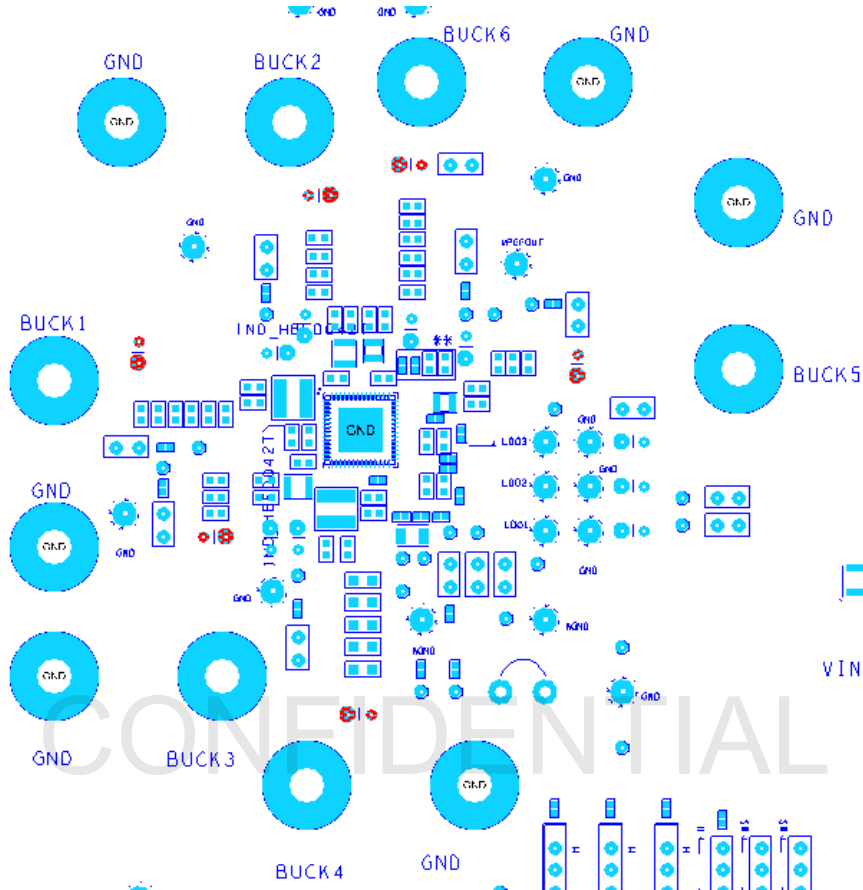

Figure 9. Locations for Measurement of Buck Regulator Output Voltages

- Figure 10 shows locations on the PCB where the LDO regulator output voltages can be measured accurately. For each LDO regulator, there is a pair of pads with holes to which wires, pins, or connectors can be soldered, or an oscilloscope probe can be connected. The larger of each pair of pads is the positive; the smaller pad is ground.

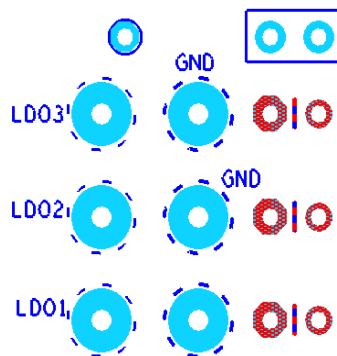

Figure 10. Locations for Measurement of LDO Regulator Output Voltages

## 2.3.6 Transient Load Circuits

### 2.3.6.1 Overview

There are two separate transient load circuits on the EVB. The load located in the green box in [Figure 11](#) can both draw current from regulator outputs and provide current to regulator outputs. This load is called LOAD1 in the following text. The load located in the purple box can only draw current from regulator outputs. This load is called LOAD2.

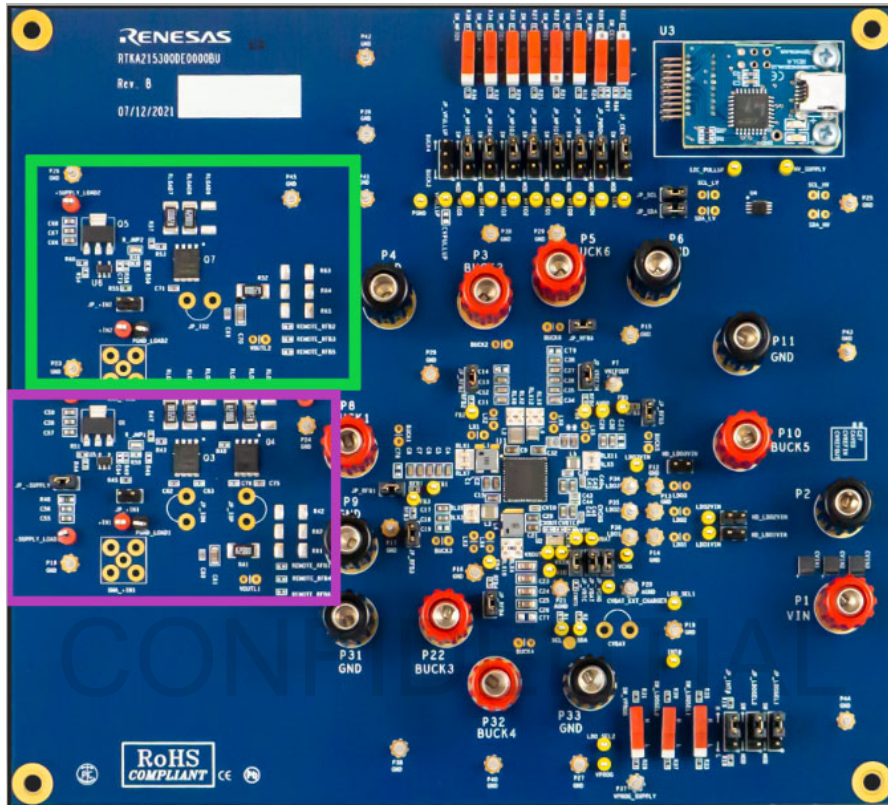

Figure 11. Location of Transient Load Circuits

By populating vacant resistor positions with links (copper wire is suitable):

- Buck1, Buck4, and Buck6 can be connected to LOAD1.
- Buck2, Buck3, and Buck5 can be connected to LOAD2.
- LOAD1 is only to be used to provide current when it is connected to Buck6 in VTT mode.
- The transient load circuits can be configured to shape the current to suit many different applications.

The default configuration has resistors fitted in series with the sources and the drains of the load FETs, Q3 and Q4 (LOAD1) and Q7 (LOAD2). Typically, the resistors are too low in value to limit the load current amplitude to the required level. The load current amplitude and slew rate can be controlled by driving the FET in its ohmic region, but it is highly sensitive to the gate voltage, derived from the input signal amplitude. There is not a defined or consistent relationship so carefully adjust the input signal and monitor the current.

Capacitors C70 (LOAD1) or C61 (LOAD2) provide the initial FET current (at both rising and falling edges). The capacitor values can be adjusted to shape the load current edges applied to the regulators. JP\_I0N, JP\_I0P, and JP\_I02 are intended to simplify connection of a wire loop and current probe. However, the current in JP\_I0N, JP\_I0P, or JP\_I02 includes the capacitor current so it is not the same as the load applied to the regulator output. Therefore, if C61 and/or C70 are fitted, measure the load current in R41 (LOAD1) or R52 (LOAD2). Alternatively, measure the load current in the resistor or link that is in series with each regulator output and connects to either R41 or R52.

If the previous procedure does not produce the required transient load currents, complete the following alternative procedure.

- Set the input signal amplitude to about 5V (-5V to drive Q4 on). This turns the FETs on fully and their resistances are relatively low. (Make the input signal positive with respect to VEXT to turn Q4 off.)
- Short (replace with a link) the resistors in series with the sources of the FETs.
- Remove C61 and C70.
- Change R41 and R52 to values that set the load current amplitude. Adjust VEXT to control the current provided to buck6.
- Adjust the resistors in series with the FET gates (R40, R43, and R53) to achieve the required rise and fall times.
- Measure the current in JP\_ION, JP\_IOP, or JP\_IO2.

### 2.3.6.2 Configuration of LOAD1

Table 3 shows how to configure LOAD1 to either draw current from a regulator output or provide current to Buck6.

**Table 3. LOAD1 Configuration**

Component	To Draw Current from the Regulator	To Provide Current to the Regulator
R40	Open	Link
JP_IOP	Open	Link
JP_ION	Link	Open
R43	Link	Open
R48	Link	Open
JP_-SUPPLY	Link	Open
-Supply_Load1	Open	Connect to negative supply
+Supply_Load1	Connect to positive supply	Connect to positive supply
VEXT	Open	Connect to positive supply

Figure 12 shows the locations of the points used for configuration.

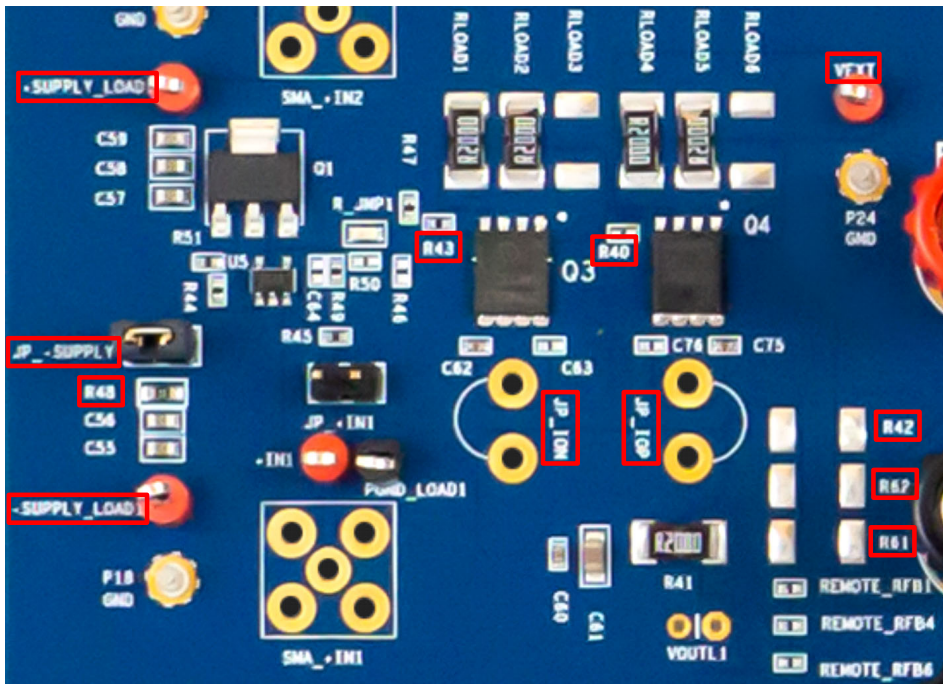

Figure 12. LOAD1 Configuration

### 2.3.6.3 Connection of LOAD1 to Buck Regulators

1. To connect Buck1 to LOAD1: link R42; open R61 and R62.
2. To connect Buck4 to LOAD1: link R61; open R42 and R62.
3. To connect Buck6 to LOAD1: link R62; open R42 and R61.

### 2.3.6.4 Connection of LOAD2 to Buck Regulators

1. To connect Buck2 to LOAD2: link R63; open R64 and R65.
2. To connect Buck3 to LOAD2: link R64; open R63 and R65.
3. To connect Buck5 to LOAD2: link R65; open R63 and R64.

#### 2.3.6.4.1 Setting Transient Load Current

If the transient load is required to start or finish at a non-zero level, apply a steady-state load (at that non-zero level) to the regulator output, preventing the steady-state power being dissipated in the transient load resistors. For example, if transient load of 0.2A to 1.0A is required, connect a 0.2A load to the regulator output and set the transient to be 0 to 0.8A.

*Caution:* High duty cycle and large currents might overheat the load.

*Caution:* It might not be possible to achieve large, fast transient loads without overshoot.

#### 2.3.6.4.2 Setting LOAD1 to Draw Current

1. Configure LOAD1 to draw current, as shown in [Table 3](#).
2. Connect a +10V power supply to +SUPPLY\_LOAD1.
3. Connect the ground of the +10V power supply to P18, P23, and P26.
4. Connect a signal generator to +IN1.
5. Apply a positive voltage pulse to +IN1 and adjust its amplitude and slew rate to achieve the desired transient current. *Recommendation:* Start with amplitude less than 2V and increase in steps of less than 0.1V.



### 2.3.6.4.3 Setting LOAD1 to Provide Current

1. Configure LOAD1 to provide current, as shown in [Table 3](#).
2. Connect a +4V power supply to +SUPPLY\_LOAD1.
3. Connect a -10V power supply to -SUPPLY\_LOAD1.
4. Connect a positive power supply to VEXT and set it a little higher than the regulator output voltage.  
*Note:* Use the voltage at VEXT to control current amplitude.
5. Connect the grounds of the power supplies to P18, P23, and P26.
6. Connect a signal generator to +IN1.
7. Apply a negative voltage pulse to +IN1 and adjust its amplitude and slew rate, in conjunction with VEXT, to achieve the required transient current. For example, with RLOAD4 and RLOAD5 shorted, with R41 = 0.2Ω, and with output voltage set to 0.6V, set VEXT to about 0.8V to achieve 1A.

### 2.3.6.4.4 Setting LOAD2 to Draw Current

1. Connect a +10V power supply to +SUPPLY\_LOAD2.
2. Connect the ground of the +10V power supply to P18, P23, and P26.
3. Connect a signal generator to +IN2.
4. Apply a positive voltage pulse to +IN and adjust its amplitude and slew rate to achieve the required transient current.

## 3. Board Design

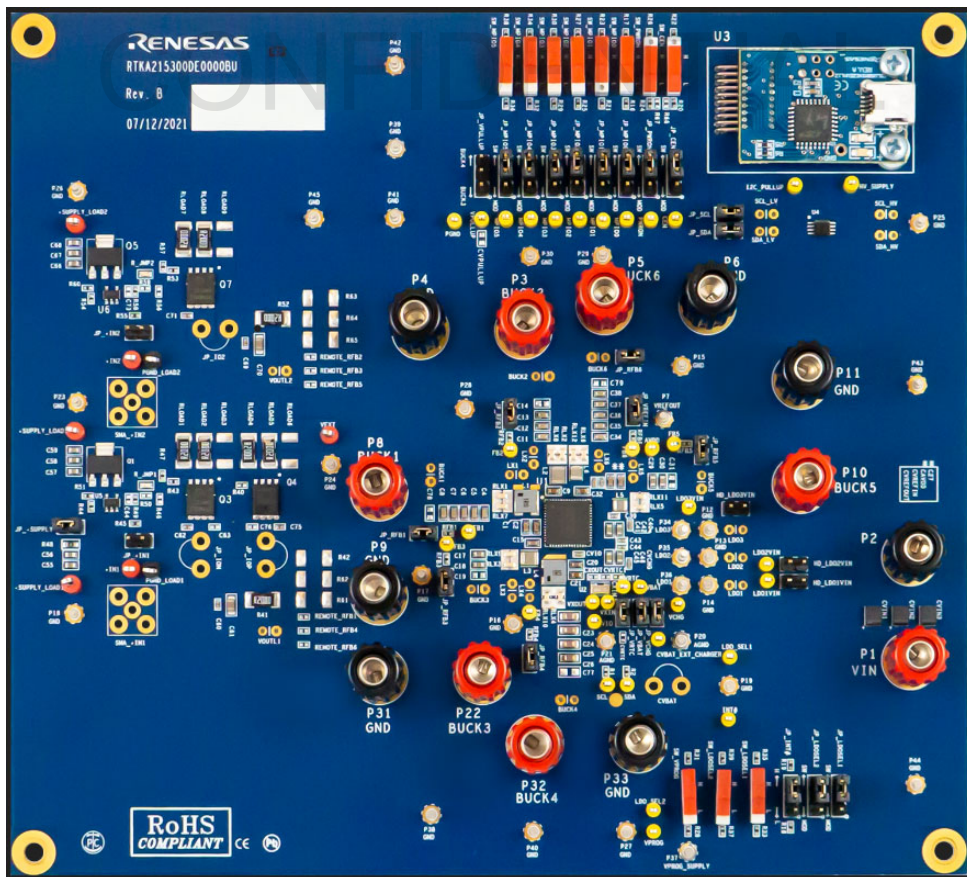

Figure 13. RTKA215300DE0000BU Evaluation Board (Top)

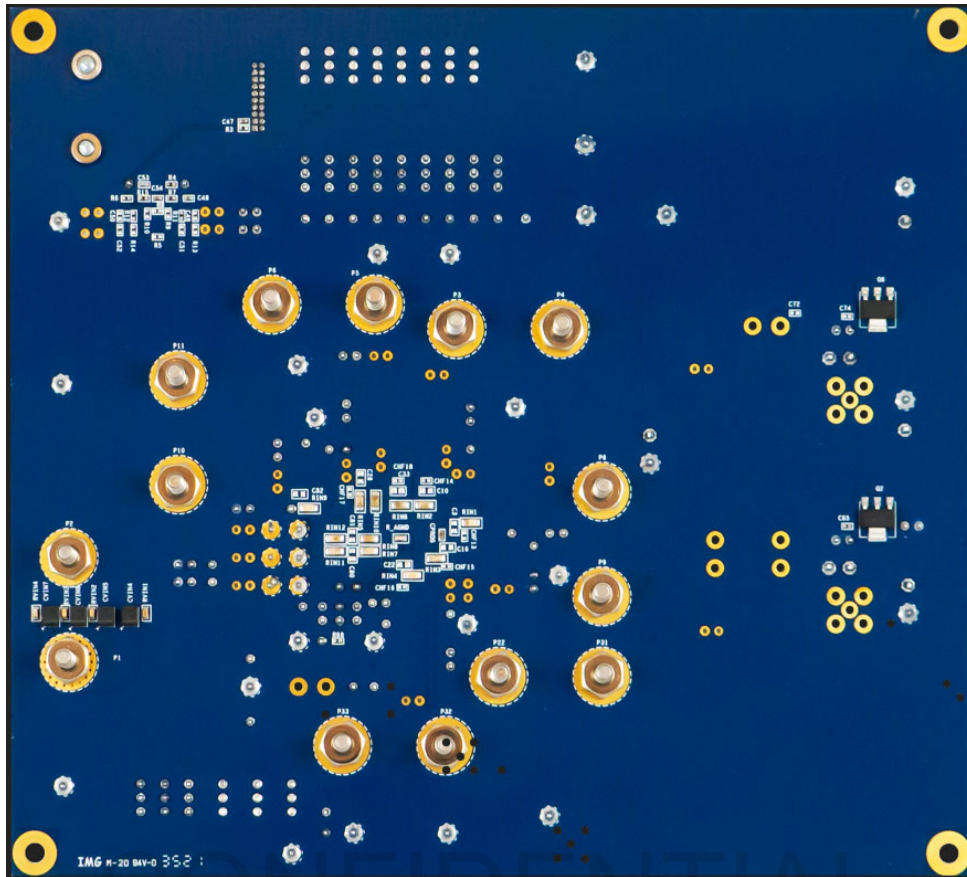

Figure 14. RTKA215300DE0000BU Evaluation Board (Bottom)

### 3.1 Layout Guidelines

For layout guidelines, see the *RAA215300 Datasheet* and the *RZ/G2L MPU Evaluation Board Manual* [RTK9744L23S01000BE](#).



### 3.2 Schematic Diagram

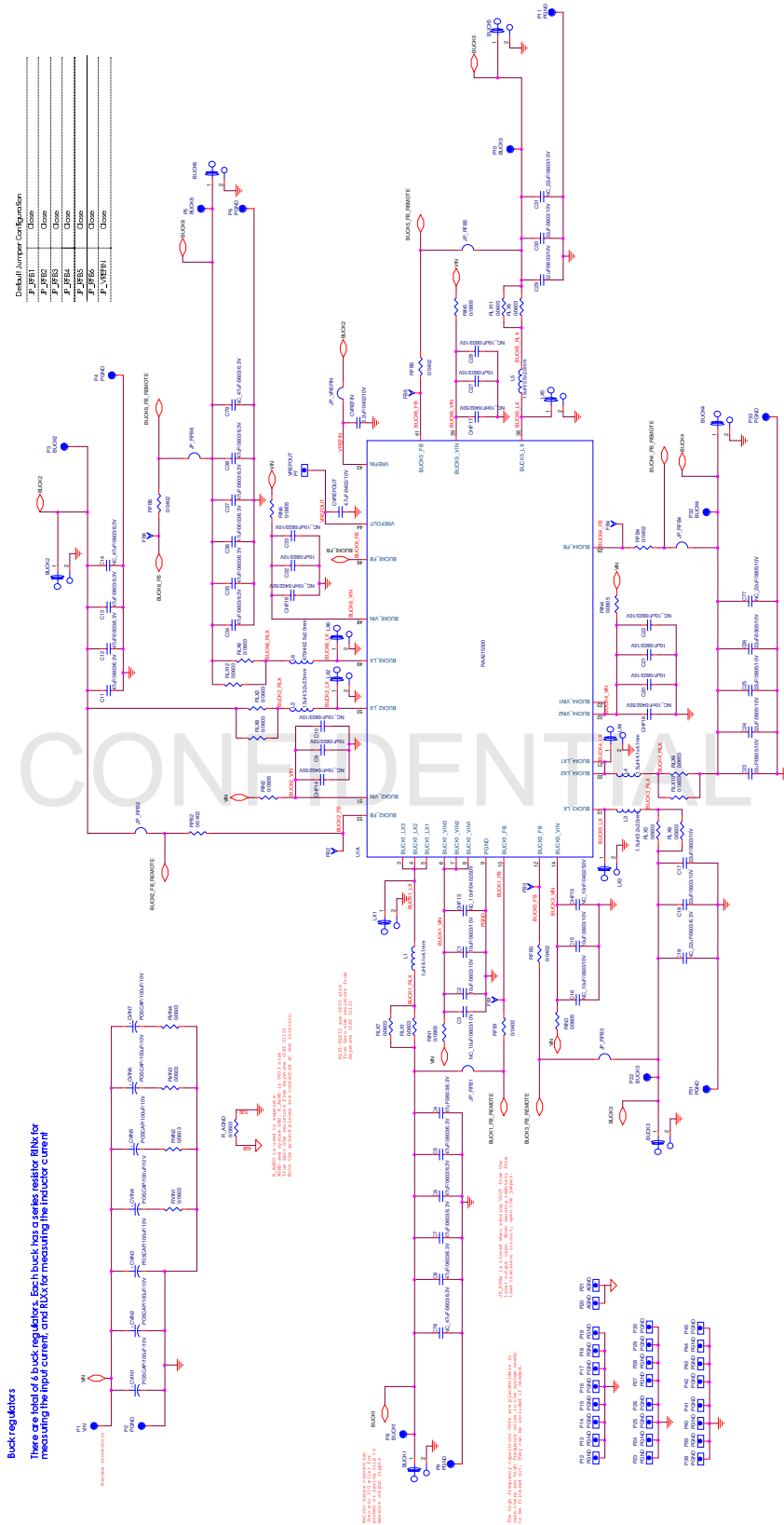
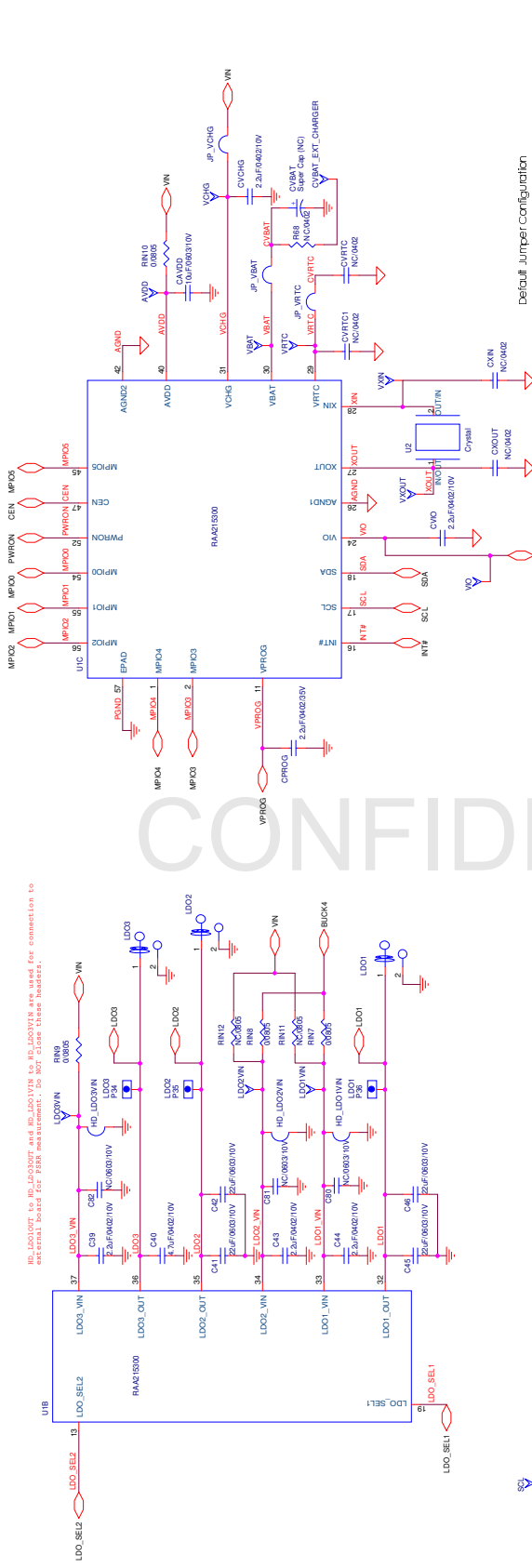

Figure 15. RTKA215300DE000BU EVB Schematic Sheet 1

LDOs, RTC, Coin Cell Battery Charger and USB connector



Default Jumper Configuration

JP_SCL	Close
JP_SDA	Close
JP_VRTC	Open
JP_VBAT	Close
JP_VCHG	Close

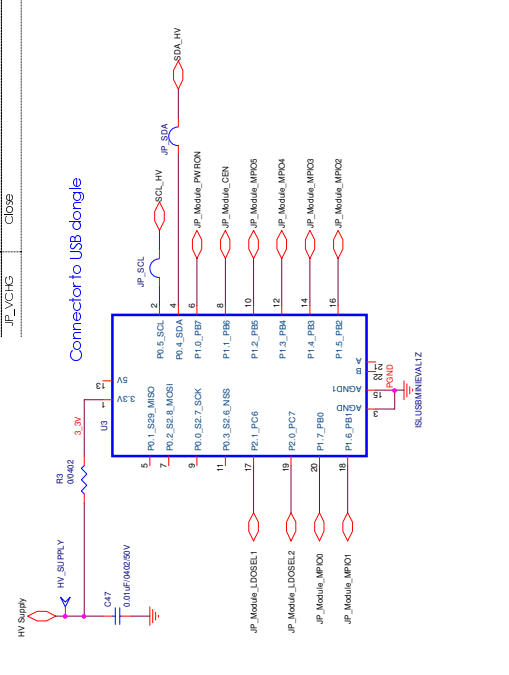

I2C Level Shifter (convert the 3.3V supply from USB dongle to a lower supply voltage)

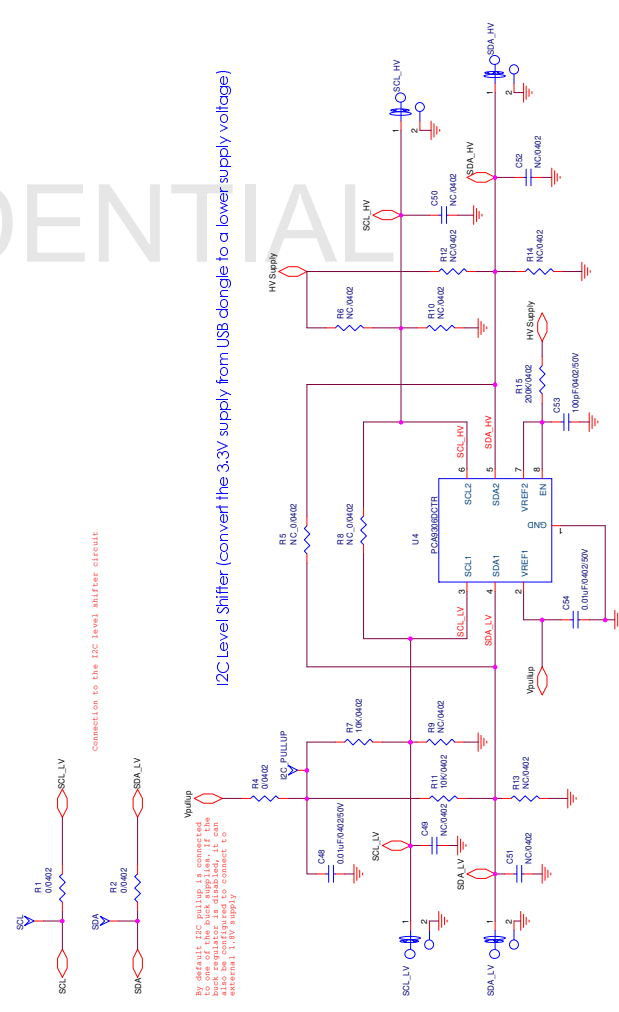

Figure 16. RTKA215300DE000BU EVB Schematic Sheet 2



For more information about load transient circuit, review Evaluation Board Manual

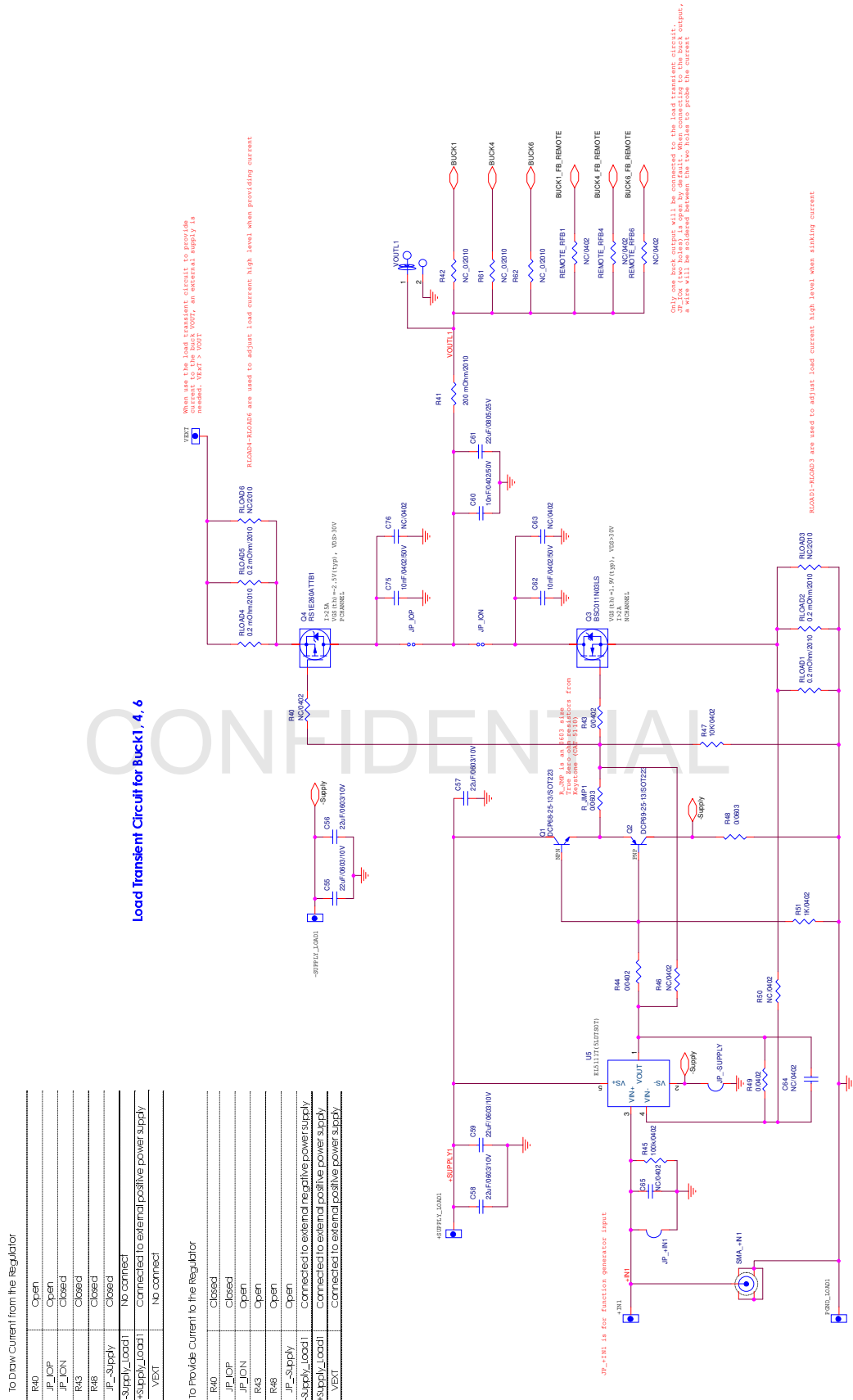

Figure 18. RTKA215300DE000BU EVB Schematic Sheet 4

For more information about load transient circuit, review Evaluation Board Manual

Load Transient Circuit for Buck2, 3, 5

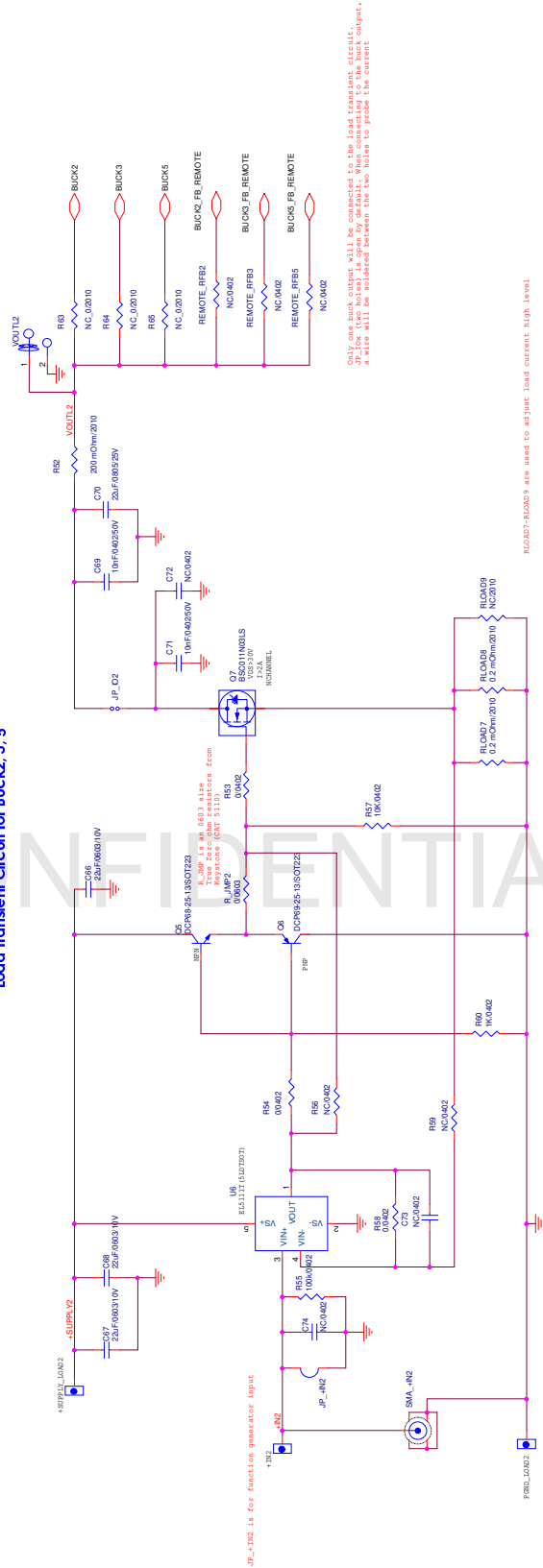

Figure 19. RTKA215300DE000BU EVB Schematic Sheet 5

### 3.3 Bill of Materials

The RTKA215300DE0000BU BOM is available in the design files on the [RTKA215300DE0000BU](#) page.

### 3.4 Board Layout

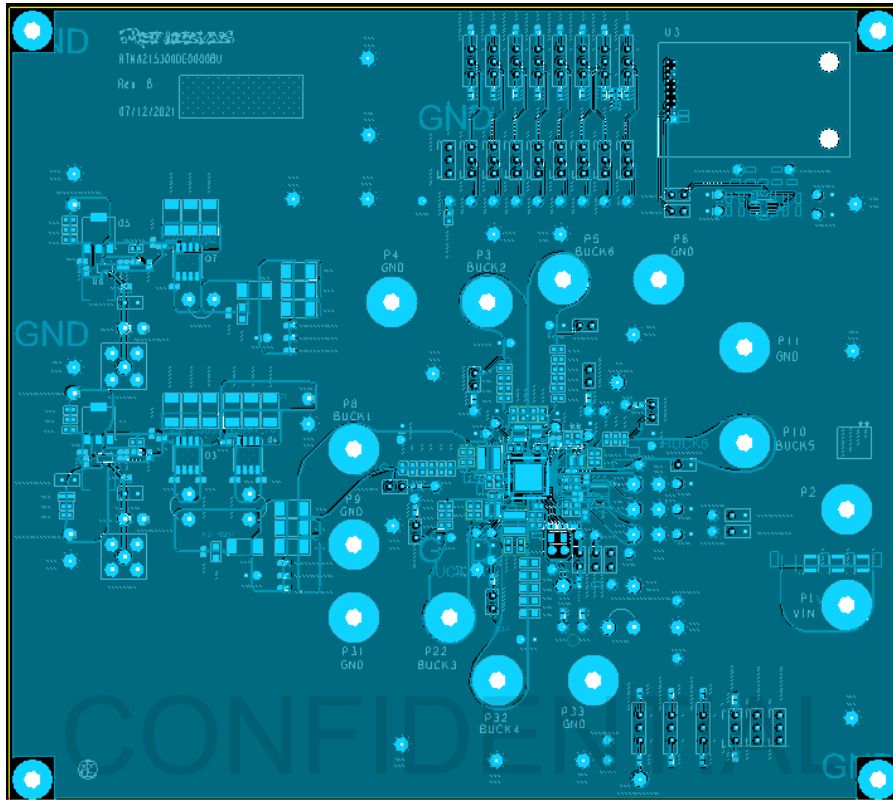

Figure 20. Top Layer Copper

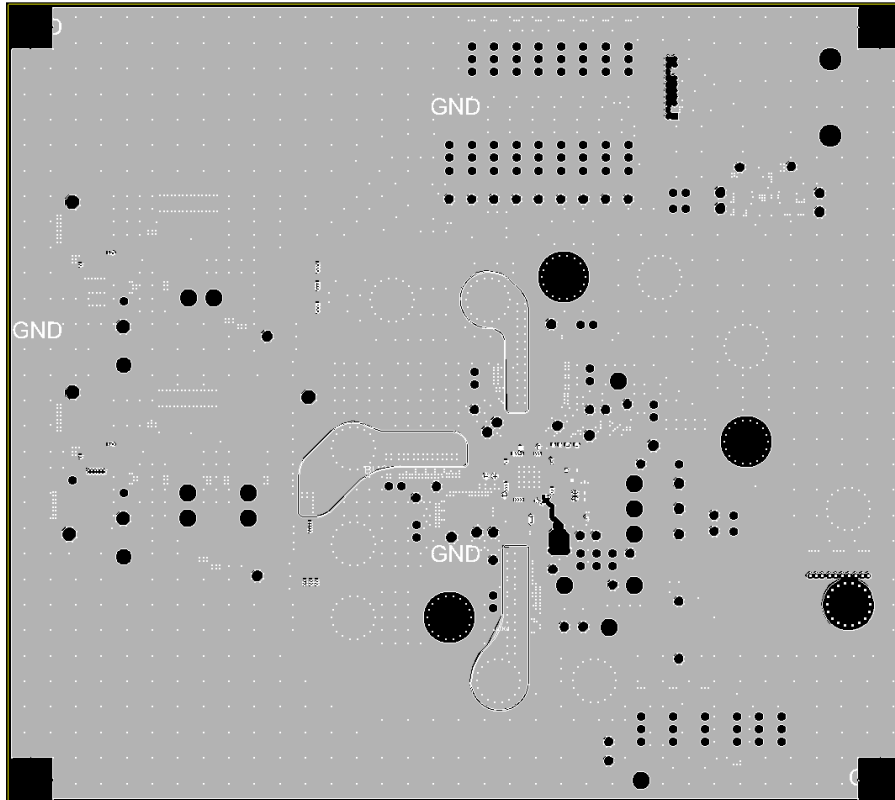

Figure 21. Layer 2 Copper

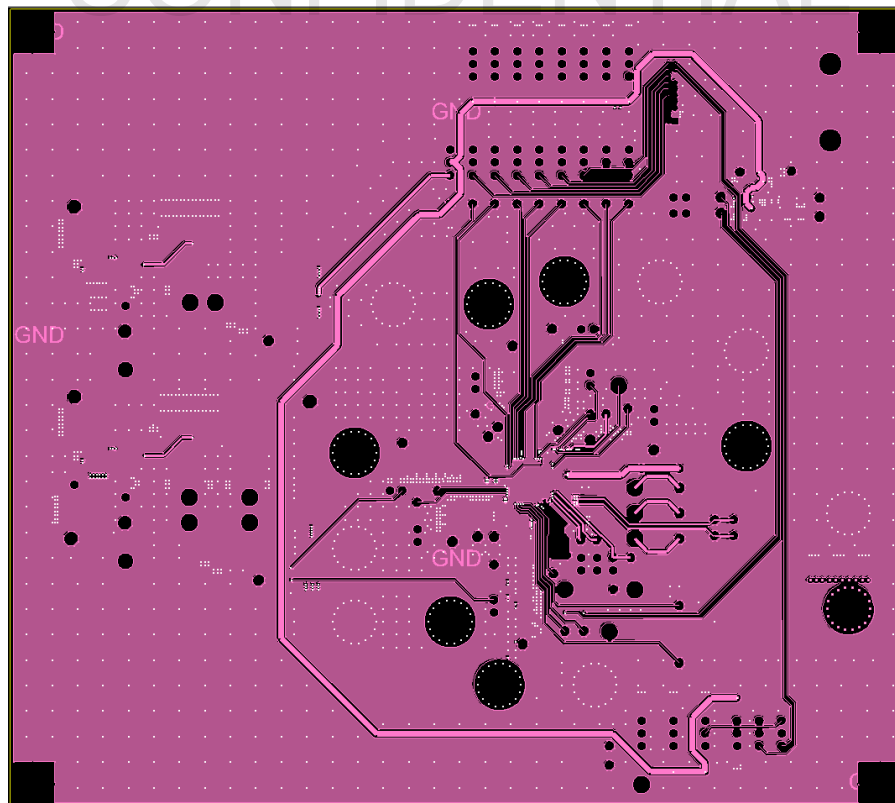

Figure 22. Layer 3 Copper

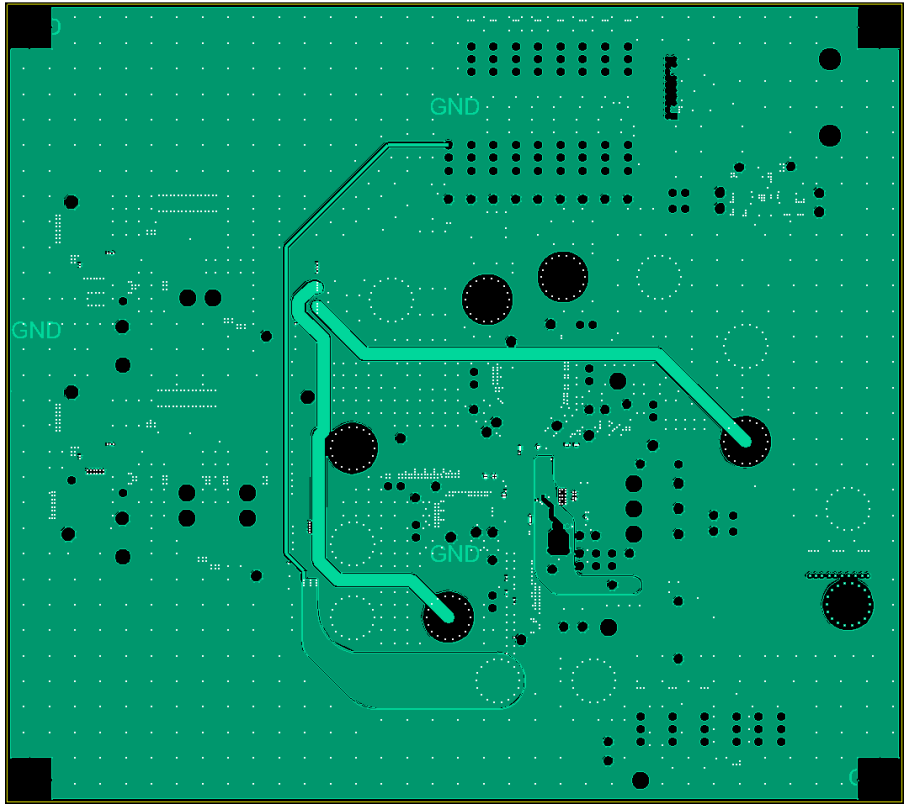

Figure 23. Layer 4 Copper

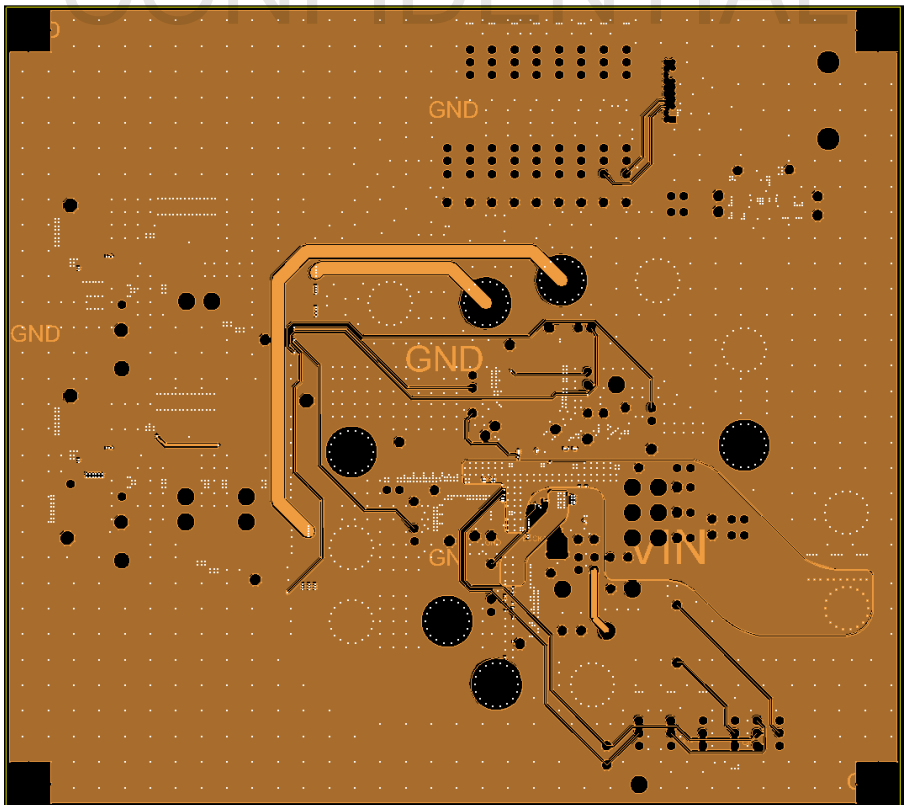

Figure 24. Layer 5 Copper



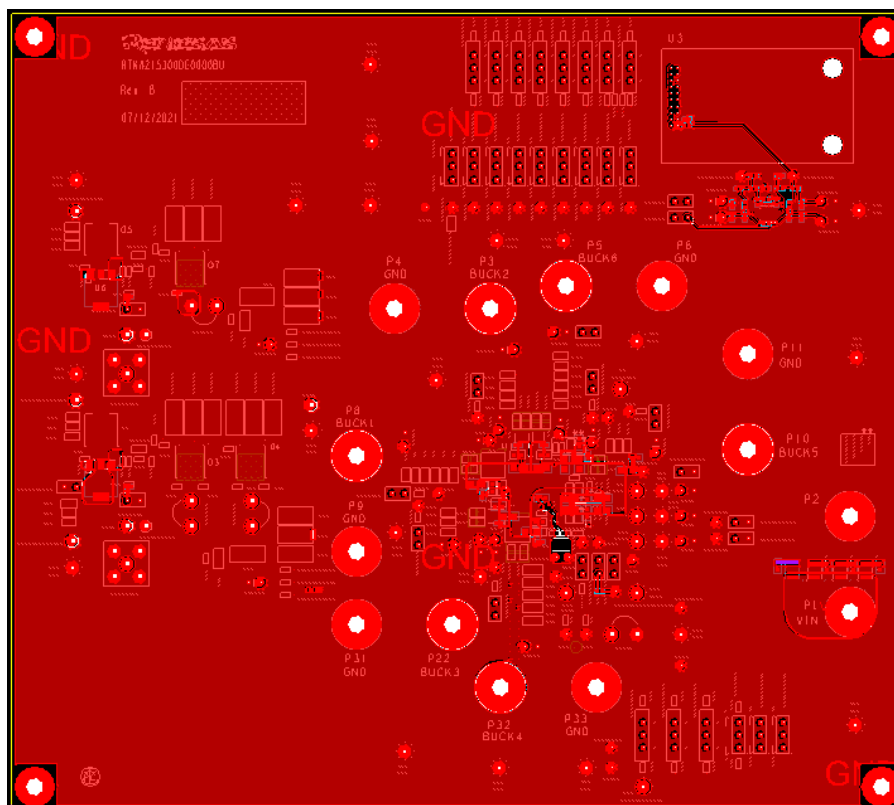

Figure 25. Bottom Layer Copper

## 4. Ordering Information

Part Number	Description
RTKA215300DE0000BU	Evaluation board for RAA215300A2GNP#HA0

## 5. Revision History

Revision	Date	Description
1.02	Dec 19, 2022	Updated Table 2. Updated Power Supplies section. Updated schematics.
1.01	Aug 10, 2022	Updated schematics.
1.00	Jun 30, 2022	Initial release

## IMPORTANT NOTICE AND DISCLAIMER

RENESAS ELECTRONICS CORPORATION AND ITS SUBSIDIARIES (“RENESAS”) PROVIDES TECHNICAL SPECIFICATIONS AND RELIABILITY DATA (INCLUDING DATASHEETS), DESIGN RESOURCES (INCLUDING REFERENCE DESIGNS), APPLICATION OR OTHER DESIGN ADVICE, WEB TOOLS, SAFETY INFORMATION, AND OTHER RESOURCES “AS IS” AND WITH ALL FAULTS, AND DISCLAIMS ALL WARRANTIES, EXPRESS OR IMPLIED, INCLUDING, WITHOUT LIMITATION, ANY IMPLIED WARRANTIES OF MERCHANTABILITY, FITNESS FOR A PARTICULAR PURPOSE, OR NON-INFRINGEMENT OF THIRD PARTY INTELLECTUAL PROPERTY RIGHTS.

These resources are intended for developers skilled in the art designing with Renesas products. You are solely responsible for (1) selecting the appropriate products for your application, (2) designing, validating, and testing your application, and (3) ensuring your application meets applicable standards, and any other safety, security, or other requirements. These resources are subject to change without notice. Renesas grants you permission to use these resources only for development of an application that uses Renesas products. Other reproduction or use of these resources is strictly prohibited. No license is granted to any other Renesas intellectual property or to any third party intellectual property. Renesas disclaims responsibility for, and you will fully indemnify Renesas and its representatives against, any claims, damages, costs, losses, or liabilities arising out of your use of these resources. Renesas' products are provided only subject to Renesas' Terms and Conditions of Sale or other applicable terms agreed to in writing. No use of any Renesas resources expands or otherwise alters any applicable warranties or warranty disclaimers for these products.

(Rev.1.0 Mar 2020)

### Corporate Headquarters

TOYOSU FORESIA, 3-2-24 Toyosu,  
Koto-ku, Tokyo 135-0061, Japan  
[www.renesas.com](http://www.renesas.com)

### Contact Information

For further information on a product, technology, the most up-to-date version of a document, or your nearest sales office, please visit:  
[www.renesas.com/contact/](http://www.renesas.com/contact/)

### Trademarks

Renesas and the Renesas logo are trademarks of Renesas Electronics Corporation. All trademarks and registered trademarks are the property of their respective owners.