

ISL43485

3.3V, Low Power, 30Mbps, RS-485/RS-422 Transceiver

FN6071  
Rev.2.00  
Sep 19, 2018

The Renesas [ISL43485](#) is a high speed BiCMOS 3.3V powered, single transceiver that meets both the RS-485 and RS-422 standards for balanced communication. Unlike some competitive devices, this transceiver is specified for 10% tolerance supplies (3V to 3.6V).

Data rates up to 30Mbps are achievable by using this transceiver, which features higher slew rates.

Logic inputs (for example, DI and DE) accept signals in excess of 5.5V, making them compatible with 5V logic families.

The receiver (Rx) inputs feature a “fail-safe if open” design, which ensures a logic high output if Rx inputs are floating. The ISL43485 presents a “single unit load” to the RS-485 bus, which allows up to 32 transceivers on the network.

The driver (Tx) outputs are short-circuit protected, even for voltages exceeding the power supply voltage. Additionally, on-chip thermal shutdown circuitry disables the Tx outputs to prevent damage if power dissipation becomes excessive.

**Related Literature**

For a full list of related documents, visit our website:

- [ISL43485](#) product page

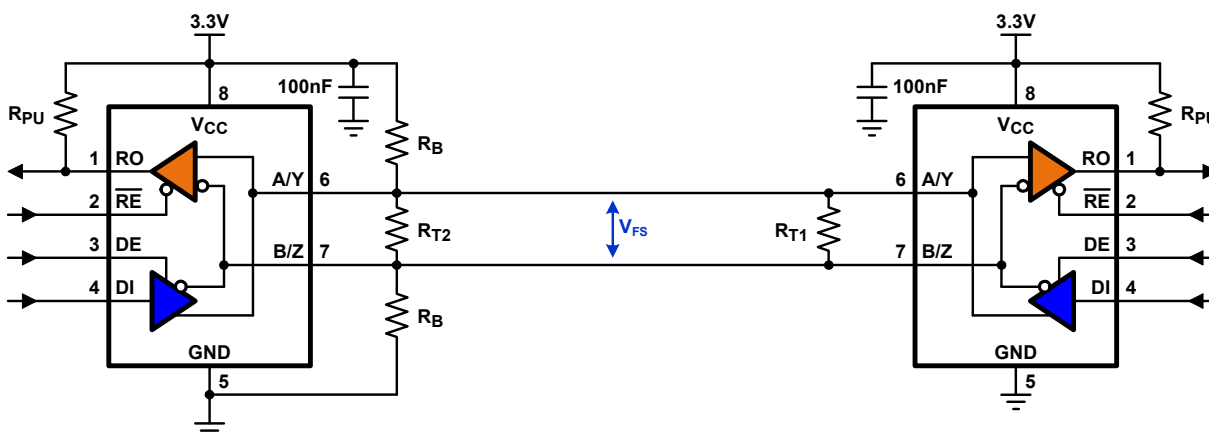
**Features**

- High data rate. . . . . up to 30Mbps
- Operates from a single +3.3V supply (10% tolerance)
- Interoperable with 5V logic
- Single unit load allows up to 32 devices on the bus
- Low current shutdown mode . . . . . 15nA
- -7V to +12V common-mode input voltage range
- Three state Rx and Tx outputs
- 10ns propagation delay, 1ns skew
- Half duplex pinout
- Current limiting and thermal shutdown for driver overload protection
- Pb-free available (RoHS compliant)

**Applications**

- SCSI “Fast 20” drivers and receivers
- Factory automation
- Data loggers
- Security networks
- Building environmental control systems
- Industrial/process control networks
- Level translators

**Typical Operating Circuit**



To calculate the resistor values, refer to [TB509](#).

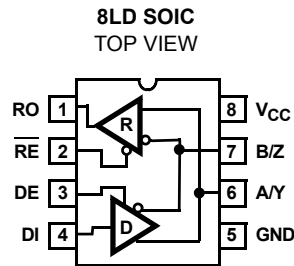
## Ordering Information

PART NUMBER (Notes 2, 3)	PART MARKING	TEMP. RANGE (°C)	TAPE AND REEL (UNITS) (Note 1)	PACKAGE (RoHS Compliant)	PKG. DWG. #
ISL43485IBZ	43485IBZ	-40 to +85	-	8 Ld SOIC	M8.15
ISL43485IBZ-T	43485IBZ	-40 to +85	2.5k	8 Ld SOIC	M8.15

### NOTES:

- Refer to [TB347](#) for details about reel specifications.
- Pb-free products employ special Pb-free material sets; molding compounds/die attach materials and 100% matte tin plate termination finish, which are RoHS compliant and compatible with both SnPb and Pb-free soldering operations. Pb-free products are MSL classified at Pb-free peak reflow temperatures that meet or exceed the Pb-free requirements of IPC/JEDEC J STD-020.
- For Moisture Sensitivity Level (MSL), see the [ISL43485](#) product information page. For more information about MSL, see [TB363](#).

## Pinout



## Pin Descriptions

PIN	FUNCTION
RO	Receiver output: RO is high if $A > B$ by at least 0.2V; RO is low if $A < B$ by 0.2V or more; RO is high if A and B are unconnected (floating).
$\overline{RE}$	Receiver output enable. RO is enabled when $\overline{RE}$ is low; RO is high impedance when $\overline{RE}$ is high.
DE	Driver output enable. The driver outputs, Y and Z, are enabled by bringing DE high. They are high impedance when DE is low.
DI	Driver input. A low on DI forces output Y low and output Z high. Similarly, a high on DI forces output Y high and output Z low.
GND	Ground connection.
A/Y	Noninverting receiver input and noninverting driver output. Pin is an input if DE = 0; pin is an output if DE = 1.
B/Z	Inverting receiver input and inverting driver output. Pin is an input if DE = 0; pin is an output if DE = 1.
V <sub>CC</sub>	System power supply input (3V to 3.6V).

## Truth Tables

TRANSMITTING				
INPUTS			OUTPUTS	
$\overline{RE}$	DE	DI	Z	Y
X	1	1	0	1
X	1	0	1	0
0	0	X	High-Z	High-Z
1	0	X	High-Z *	High-Z *

NOTE: \*Shutdown Mode

RECEIVING			
INPUTS			OUTPUT
$\overline{RE}$	DE	A-B	RO
0	0	$\geq +0.2V$	1
0	0	$\leq -0.2V$	0
0	0	Inputs Open	1
1	0	X	High-Z *
1	1	X	High-Z

NOTE: \*Shutdown Mode

**Absolute Maximum Ratings**

V <sub>CC</sub> to Ground	7V
Input Voltages	
DI, DE, RE	-0.5V to +7V
Input/Output Voltages	
A/Y, B/Z	-8V to +12.5V
RO	-0.5V to (V <sub>CC</sub> + 0.5V)
Short-Circuit Duration	
Y, Z	Continuous

**Thermal Information**

Thermal Resistance (Typical, <a href="#">Note 4</a> )	θ <sub>JA</sub> (°C/W)
8 Ld SOIC Package	170
Maximum Junction Temperature (Plastic Package)	+150°C
Maximum Storage Temperature Range	-65°C to +150°C
Maximum Lead Temperature (Soldering 10s) (Lead Tips Only)	+300°C

**Operating Conditions**

Temperature Range	-40°C to +85°C
-------------------	----------------

**CAUTION:** Do not operate at or near the maximum ratings listed for extended periods of time. Exposure to such conditions can adversely impact product reliability and result in failures not covered by warranty.

**NOTE:**

4. θ<sub>JA</sub> is measured with the component mounted on a low-effective thermal conductivity test board in free air. See [TB379](#) for details.

**Electrical Specifications** Test Conditions: V<sub>CC</sub> = 3V to 3.6V; unless otherwise specified. Typicals are at V<sub>CC</sub> = 3.3V, T<sub>A</sub> = +25°C, [Note 5](#)

PARAMETER	SYMBOL	TEST CONDITIONS	TEMP (°C)	MIN	TYP	MAX	UNIT	
<b>DC CHARACTERISTICS</b>								
Driver Differential V <sub>OUT</sub> (no load)	V <sub>OD1</sub>		Full	-	-	V <sub>CC</sub>	V	
Driver Differential V <sub>OUT</sub> (with load)	V <sub>OD2</sub>	R <sub>L</sub> = 100Ω (RS-422) ( <a href="#">Figure 1A</a> )	Full	2	2.7	-	V	
		R <sub>L</sub> = 54Ω (RS-485) ( <a href="#">Figure 1A</a> )	Full	1.5	2.3	V <sub>CC</sub>	V	
		R <sub>L</sub> = 60Ω, -7V ≤ V <sub>CM</sub> ≤ 12V ( <a href="#">Figure 1B</a> )	Full	1.5	2.6	-	V	
Change in Magnitude of Driver Differential V <sub>OUT</sub> for Complementary Output States	ΔV <sub>OD</sub>	R <sub>L</sub> = 54Ω or 100Ω ( <a href="#">Figure 1A</a> )	Full	-	0.01	0.2	V	
Driver Common-Mode V <sub>OUT</sub>	V <sub>OC</sub>	R <sub>L</sub> = 54Ω or 100Ω ( <a href="#">Figure 1A</a> )	Full	-	1.8	3	V	
Change in Magnitude of Driver Common-Mode V <sub>OUT</sub> for Complementary Output States	ΔV <sub>OC</sub>	R <sub>L</sub> = 54Ω or 100Ω ( <a href="#">Figure 1A</a> )	Full	-	0.01	0.2	V	
Logic Input High Voltage	V <sub>IH</sub>	DE, DI, RE	Full	2	-	-	V	
Logic Input Low Voltage	V <sub>IL</sub>	DE, DI, RE	Full	-	-	0.8	V	
Logic Input Current	I <sub>IN1</sub>	DE, DI	Full	-2	-	2	μA	
		RE	Full	-25	-	25	μA	
Input Current (A/Y, B/Z)	I <sub>IN2</sub>	DE = 0V, V <sub>CC</sub> = 0V or 3.6V	V <sub>IN</sub> = 12V	Full	-	0.6	1	mA
			V <sub>IN</sub> = -7V	Full	-	-0.3	-0.8	mA
Receiver Differential Threshold Voltage	V <sub>TH</sub>	-7V ≤ V <sub>CM</sub> ≤ 12V	Full	-0.2	-	0.2	V	
Receiver Input Hysteresis	ΔV <sub>TH</sub>	V <sub>CM</sub> = 0V	+25	-	50	-	mV	
Receiver Output High Voltage	V <sub>OH</sub>	I <sub>O</sub> = -4mA, V <sub>ID</sub> = 200mV	Full	V <sub>CC</sub> - 0.4	-	-	V	
Receiver Output Low Voltage	V <sub>OL</sub>	I <sub>O</sub> = -4mA, V <sub>ID</sub> = 200mV	Full	-	-	0.4	V	

**Electrical Specifications** Test Conditions:  $V_{CC} = 3V$  to  $3.6V$ ; unless otherwise specified. Typical values are at  $V_{CC} = 3.3V$ ,  $T_A = +25^\circ C$ , [Note 5](#) (Continued)

PARAMETER	SYMBOL	TEST CONDITIONS	TEMP (°C)	MIN	TYP	MAX	UNIT	
Three-State (high impedance) Receiver Output Current	$I_{OZR}$	$0.4V \leq V_O \leq 2.4V$	Full	-1	-	1	$\mu A$	
Receiver Input Resistance	$R_{IN}$	$-7V \leq V_{CM} \leq 12V$	Full	12	19	-	$k\Omega$	
No-Load Supply Current (Note 3)	$I_{CC}$	$DI = 0V$ or $V_{CC}$	$\overline{DE} = V_{CC}$ , $RE = 0V$ or $V_{CC}$	Full	-	0.75	1.2	$mA$
			$DE = 0V$ , $RE = 0V$	Full	-	0.65	1	$mA$
Shutdown Supply Current	$I_{SHDN}$	$DE = 0V$ , $\overline{RE} = V_{CC}$ , $DI = 0V$ or $V_{CC}$	Full	-	15	100	$nA$	
Driver Short-Circuit Current, $V_O =$ High or Low	$I_{OSD1}$	$DE = V_{CC}$ , $-7V \leq V_Y$ or $V_Z \leq 12V$ ( <a href="#">Note 7</a> )	Full	-	-	250	$mA$	
Receiver Short-Circuit Current	$I_{OSR}$	$0V \leq V_O \leq V_{CC}$	Full	8	-	60	$mA$	
<b>DRIVER SWITCHING CHARACTERISTICS</b>								
Maximum Data Rate	$f_{MAX}$	( <a href="#">Figure 2A</a> )	Full	30	50	-	Mbps	
Driver Differential Output Delay	$t_{DD}$	$R_{DIFF} = 60\Omega$ , $C_L = 15pF$ ( <a href="#">Figure 2A</a> )	Full	3	10	25	ns	
Driver Differential Rise or Fall Time	$t_R$ , $t_F$	$R_{DIFF} = 60\Omega$ , $C_L = 15pF$ ( <a href="#">Figure 2A</a> )	Full	3	6	12	ns	
Driver Input to Output Delay	$t_{PLH}$ , $t_{PHL}$	$R_L = 27\Omega$ , $C_L = 15pF$ ( <a href="#">Figure 2C</a> )	Full	6	10	22	ns	
Driver Output Skew	$t_{SKEW}$	$R_L = 27\Omega$ , $C_L = 15pF$ ( <a href="#">Figure 2C</a> )	Full	-	1	5	ns	
Driver Enable to Output High	$t_{ZH}$	$R_L = 110\Omega$ , $C_L = 50pF$ , $SW = GND$ ( <a href="#">Figure 3</a> ), ( <a href="#">Note 8</a> )	Full	-	45	90	ns	
Driver Enable to Output Low	$t_{ZL}$	$R_L = 110\Omega$ , $C_L = 50pF$ , $SW = V_{CC}$ ( <a href="#">Figure 3</a> ), ( <a href="#">Note 8</a> )	Full	-	45	90	ns	
Driver Disable from Output High	$t_{HZ}$	$R_L = 110\Omega$ , $C_L = 50pF$ , $SW = GND$ ( <a href="#">Figure 3</a> )	Full	-	60	90	ns	
Driver Disable from Output Low	$t_{LZ}$	$R_L = 110\Omega$ , $C_L = 50pF$ , $SW = V_{CC}$ ( <a href="#">Figure 3</a> )	Full	-	70	100	ns	
Driver Enable from Shutdown to Output High	$t_{ZH(SHDN)}$	$R_L = 110\Omega$ , $C_L = 50pF$ , $SW = GND$ ( <a href="#">Figure 3</a> ), ( <a href="#">Notes 10, 11</a> )	Full	-	115	150	ns	
Driver Enable from Shutdown to Output Low	$t_{ZL(SHDN)}$	$R_L = 110\Omega$ , $C_L = 50pF$ , $SW = V_{CC}$ ( <a href="#">Figure 3</a> ), ( <a href="#">Notes 10, 11</a> )	Full	-	115	150	ns	
<b>RECEIVER SWITCHING CHARACTERISTICS</b>								
Maximum Data Rate	$f_{MAX}$	$V_{ID} \geq 1.5V$ with $t_r/t_f = 10ns$ , $RO$ $t_H$ & $t_L \geq 60\%$ $t_{UI}$ ( <a href="#">Figure 4</a> )	Full	27	35	-	Mbps	
Receiver Input to Output Delay	$t_{PLH}$ , $t_{PHL}$	( <a href="#">Figure 4</a> )	Full	25	45	80	ns	
Receiver Skew $ t_{PLH} - t_{PHL} $	$t_{SKD}$	( <a href="#">Figure 4</a> )	Full	-	2	12	ns	
Receiver Enable to Output High	$t_{ZH}$	$R_L = 1k\Omega$ , $C_L = 15pF$ , $SW = GND$ ( <a href="#">Figure 5</a> ), ( <a href="#">Note 9</a> )	Full	-	11	25	ns	
Receiver Enable to Output Low	$t_{ZL}$	$R_L = 1k\Omega$ , $C_L = 15pF$ , $SW = V_{CC}$ ( <a href="#">Figure 5</a> ), ( <a href="#">Note 9</a> )	Full	-	11	25	ns	
Receiver Disable from Output High	$t_{HZ}$	$R_L = 1k\Omega$ , $C_L = 15pF$ , $SW = GND$ ( <a href="#">Figure 5</a> )	Full	-	7	20	ns	

**Electrical Specifications** Test Conditions:  $V_{CC} = 3V$  to  $3.6V$ ; unless otherwise specified. Typical values are at  $V_{CC} = 3.3V$ ,  $T_A = +25^\circ C$ , [Note 5 \(Continued\)](#)

PARAMETER	SYMBOL	TEST CONDITIONS	TEMP (°C)	MIN	TYP	MAX	UNIT
Receiver Disable from Output Low	$t_{LZ}$	$R_L = 1k\Omega$ , $C_L = 15pF$ , $SW = V_{CC}$ ( <a href="#">Figure 5</a> )	Full	-	7	20	ns
Time to Shutdown	$t_{SHDN}$	( <a href="#">Note 10</a> )	Full	80	190	300	ns
Receiver Enable from Shutdown to Output High	$t_{ZH(SHDN)}$	$R_L = 1k\Omega$ , $C_L = 15pF$ , $SW = GND$ ( <a href="#">Figure 5</a> ), ( <a href="#">Notes 10, 12</a> )	Full	-	240	400	ns
Receiver Enable from Shutdown to Output Low	$t_{ZL(SHDN)}$	$R_L = 1k\Omega$ , $C_L = 15pF$ , $SW = V_{CC}$ ( <a href="#">Figure 5</a> ), ( <a href="#">Notes 10, 12</a> )	Full	-	240	400	ns

## NOTES:

- All currents into device pins are positive; all currents out of device pins are negative. All voltages are referenced to device ground unless otherwise specified.
- Supply current specification is valid for loaded drivers when  $DE = 0V$ .
- Applies to peak current. See "[Typical Performance Curves](#)" on [page 9](#) for more information.
- When testing this parameter, keep  $\overline{RE} = 0$  to prevent the device from entering SHDN.
- When testing this parameter, the  $\overline{RE}$  signal high time must be short enough (typically  $<100ns$ ) to prevent the device from entering SHDN.
- The ISL43485 is put into shutdown by bringing  $\overline{RE}$  high and  $DE$  low. If the inputs are in this state for less than  $80ns$ , the parts are ensured not to enter shutdown. If the inputs are in this state for at least  $300ns$ , the parts are ensured to have entered shutdown. See "[Low Power Shutdown Mode](#)" on [page 8](#).
- Keep  $\overline{RE} = V_{CC}$ , and set the  $DE$  signal low time  $>300ns$  to ensure that the device enters SHDN.
- Set the  $\overline{RE}$  signal high time  $>300ns$  to ensure that the device enters SHDN.

### Test Circuits and Waveforms

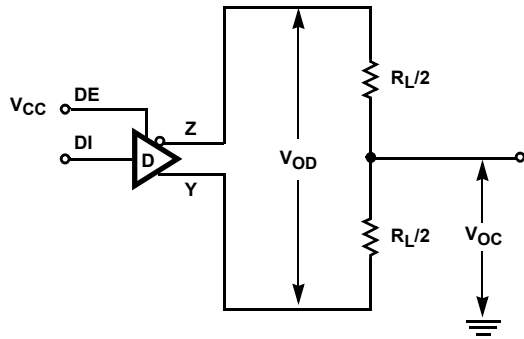
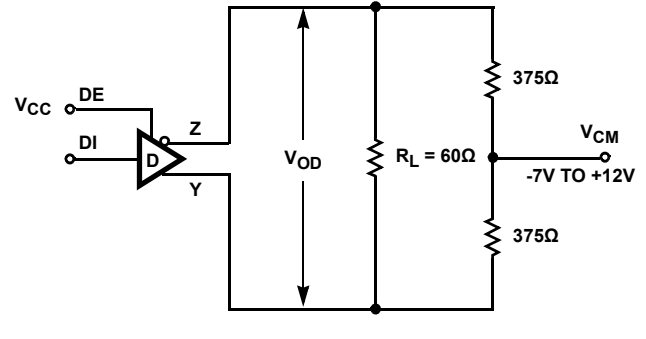
FIGURE 1A.  $V_{OD}$  AND  $V_{OC}$ FIGURE 1B.  $V_{OD}$  WITH COMMON MODE LOAD

FIGURE 1. DC DRIVER TEST CIRCUITS

**Test Circuits and Waveforms** (Continued)

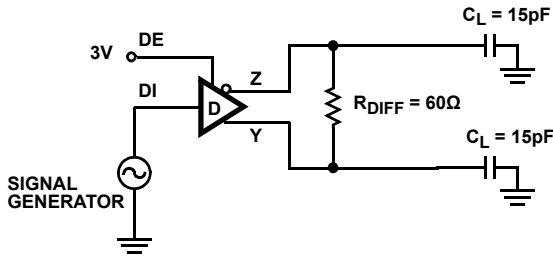


FIGURE 2A. DIFFERENTIAL TEST CIRCUIT

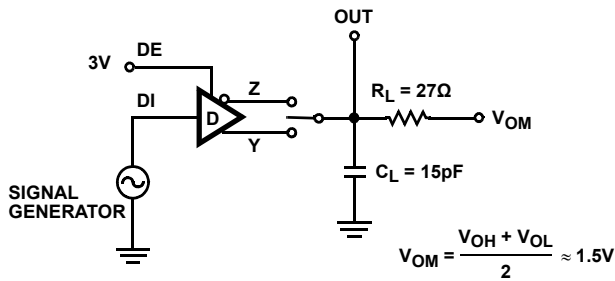


FIGURE 2C. SINGLE ENDED TEST CIRCUIT

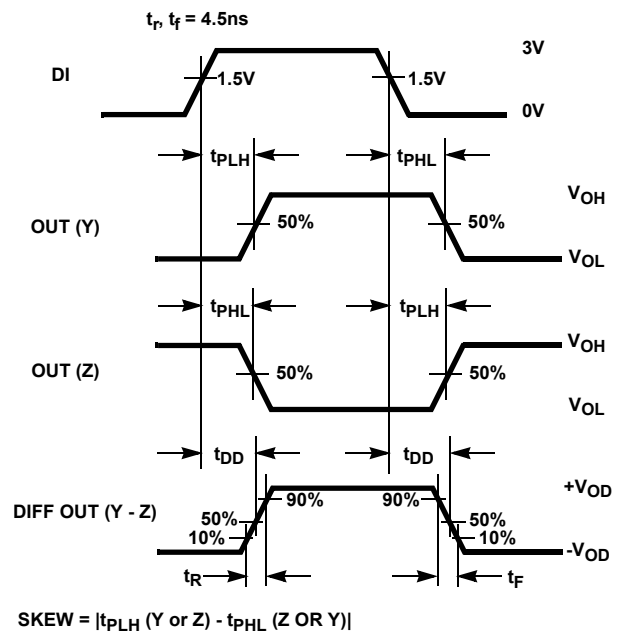
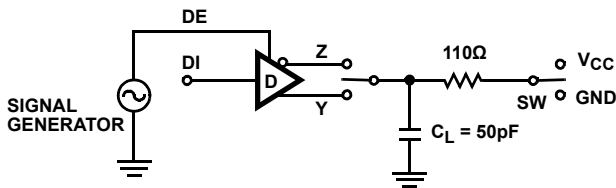


FIGURE 2B. MEASUREMENT POINTS

FIGURE 2. DRIVER DATA RATE, PROPAGATION DELAY AND DIFFERENTIAL TRANSITION TIMES



PARAMETER	OUTPUT	RE	DI	SW
t <sub>HZ</sub>	Y/Z	X	1/0	GND
t <sub>LZ</sub>	Y/Z	X	0/1	V <sub>CC</sub>
t <sub>ZH</sub>	Y/Z	0 (Note 8)	1/0	GND
t <sub>ZL</sub>	Y/Z	0 (Note 8)	0/1	V <sub>CC</sub>
t <sub>ZH(SHDN)</sub>	Y/Z	1 (Note 11)	1/0	GND
t <sub>ZL(SHDN)</sub>	Y/Z	1 (Note 11)	0/1	V <sub>CC</sub>

FIGURE 3A. TEST CIRCUIT

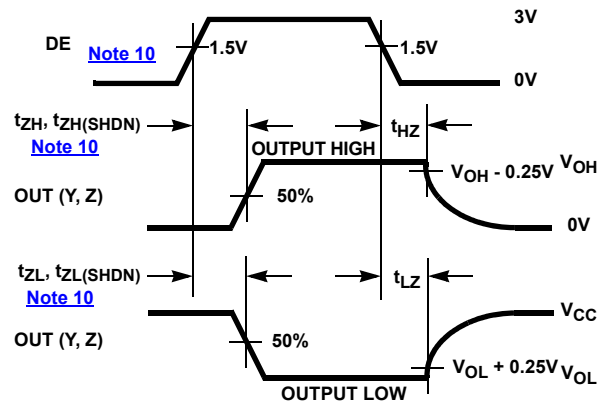


FIGURE 3B. MEASUREMENT POINTS

FIGURE 3. DRIVER ENABLE AND DISABLE TIMES

## Test Circuits and Waveforms (Continued)

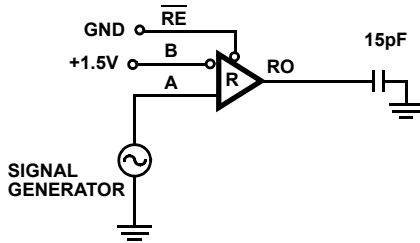


FIGURE 4A. TEST CIRCUIT

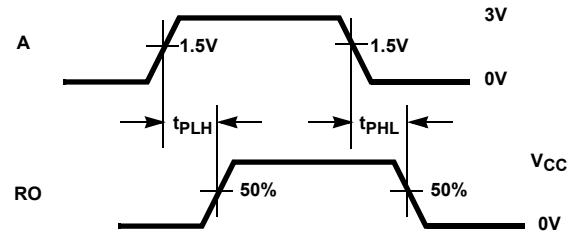


FIGURE 4B. MEASUREMENT POINTS

FIGURE 4. RECEIVER DATA RATE AND PROPAGATION DELAY

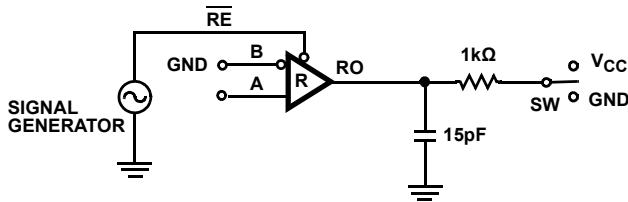


FIGURE 5A. TEST CIRCUIT

PARAMETER	DE	A	SW
$t_{HZ}$	0	+1.5V	GND
$t_{LZ}$	0	-1.5V	$V_{CC}$
$t_{ZH}$ (Note 9)	0	+1.5V	GND
$t_{ZL}$ (Note 9)	0	-1.5V	$V_{CC}$
$t_{ZH(SHDN)}$ (Note 12)	0	+1.5V	GND
$t_{ZL(SHDN)}$ (Note 12)	0	-1.5V	$V_{CC}$

FIGURE 5. RECEIVER ENABLE AND DISABLE TIMES

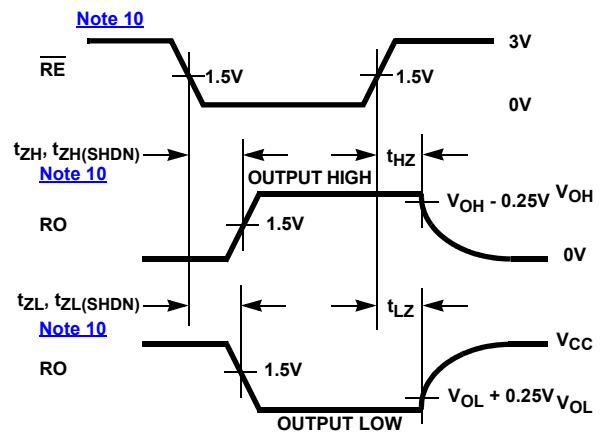


FIGURE 5B. MEASUREMENT POINTS

### Application Information

RS-485 and RS-422 are differential (balanced) data transmission standards for use in long haul or noisy environments. RS-422 is a subset of RS-485, so RS-485 transceivers are also RS-422 compliant. RS-422 is a point-to-multipoint (multidrop) standard, which allows only one driver and up to 10 receivers on each bus assuming one unit load devices. RS-485 is a true multipoint standard, which allows up to 32 one unit load devices (any combination of drivers and receivers) on each bus. To allow for multipoint operation, the RS-485 specification requires that drivers must handle bus contention without sustaining any damage.

An important advantage of RS-485 is the extended Common-Mode Range (CMR), which specifies that the driver outputs and receiver inputs withstand signals that range from +12V to -7V. RS-422 and RS-485 are intended for runs as long as 4000ft, so the wide CMR is necessary to handle ground potential differences and voltages induced in the cable by external fields.

### Receiver Features

This device uses a differential input receiver for maximum noise immunity and common-mode rejection. Input sensitivity is  $\pm 200\text{mV}$ , as required by the RS422 and RS-485 specifications.

Receiver input impedance surpasses the RS-422 specification of  $4\text{k}\Omega$  and meets the RS-485 "Unit Load" requirement of  $12\text{k}\Omega$  minimum.

Receiver inputs function with common-mode voltages as great as +9V/-7V outside the power supplies (such as +12V and -7V), making them ideal for long networks in which induced voltages are a realistic concern.

All the receivers include a "fail-safe if open" function that ensures a high level receiver output if the receiver inputs are unconnected (floating).

The receiver easily meets the data rate supported by the driver, and the receiver output is tri-statable through the active low  $\overline{\text{RE}}$  input.

### Driver Features

The RS-485, RS-422 driver is a differential output device that delivers at least 1.5V across a 54Ω load (RS-485), and at least 2V across a 100Ω load (RS-422) even with  $V_{CC} = 3V$ . The driver features low propagation delay skew to maximize bit width and to minimize EMI, and it is tri-statable using the active high DE input.

Outputs of the ISL43485 driver are not slew rate limited, so faster output transition times allow data rates of at least 30Mbps.

### Data Rate, Cables, and Terminations

Twisted pair cable is the cable of choice for RS-485, RS-422 networks. Twisted pair cables pick up noise and other electromagnetically induced voltages as common-mode signals, which are effectively rejected by the differential receivers in this IC.

RS-485, RS-422 are intended for network lengths up to 4000ft, but the maximum system data rate decreases as the transmission length increases. Devices operating at 30Mbps are often limited to lengths of less than 100ft. [Figure 6 on page 9](#) details the ISL43485's 30Mbps performance driving 200ft of "CAT5" cable terminated in 120Ω at both ends. Note that the differential signal delivered to the receiver at the end of the cable (A-B) still exceeds the 1.5V peak. Longer cable lengths are possible by reducing the data rate, as shown in [Figure 7 on page 9](#) for a data rate of 20Mbps.

To minimize reflections, proper termination is imperative when using this 30Mbps device. In point-to-point or point-to-multipoint (single driver on bus) networks, terminate the main cable in its characteristic impedance (typically 120Ω) at the end farthest from the driver. In multi-receiver applications, keep stubs connecting receivers to the main cable as short as possible. In multipoint (multi-driver) systems, terminate the main cable in its characteristic impedance at both ends. Keep stubs connecting a transceiver to the main cable as short as possible.

### Built-In Driver Overload Protection

As stated previously, the RS-485 specification requires that drivers survive worst case bus contentions undamaged. The ISL43485 meets this requirement through the driver output short-circuit current limits, and on-chip thermal shutdown circuitry.

The driver output stages incorporate short-circuit current limiting circuitry which ensures that the output current never exceeds the RS-485 specification, even at the common-mode voltage range extremes. Additionally, it uses a foldback circuit which reduces the short-circuit current, and thus the power dissipation, whenever the contending voltage exceeds either supply.

In the event of a major short-circuit condition, this device's thermal shutdown feature disables the drivers whenever the die temperature becomes excessive. This eliminates the power dissipation, allowing the die to cool. The drivers automatically reenables after the die temperature drops about 15°. If the contention persists, the thermal shutdown/reenable cycle repeats until the fault is cleared. Receivers stay operational during thermal shutdown.

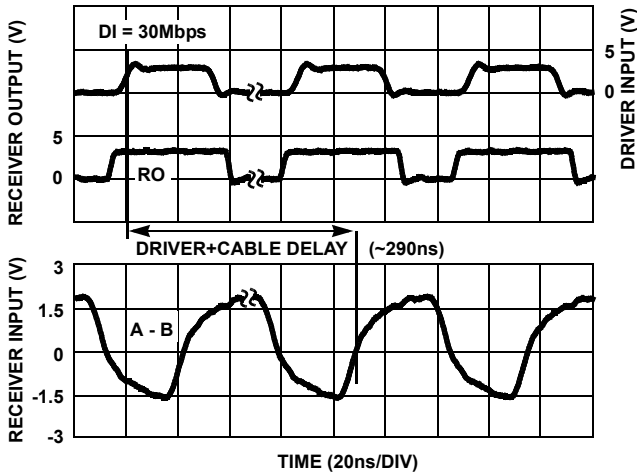
### Low Power Shutdown Mode

This BiCMOS transceiver uses a fraction of the power required by its bipolar counterparts. However, the ISL43485 includes a shutdown feature that reduces the already low quiescent  $I_{CC}$  to a 15nA trickle. They enter shutdown whenever the receiver and driver are **simultaneously** disabled ( $\overline{RE} = V_{CC}$  and  $DE = GND$ ) for a period of at least 300ns. Disabling both the driver and the receiver for less than 80ns ensures that shutdown is not entered.

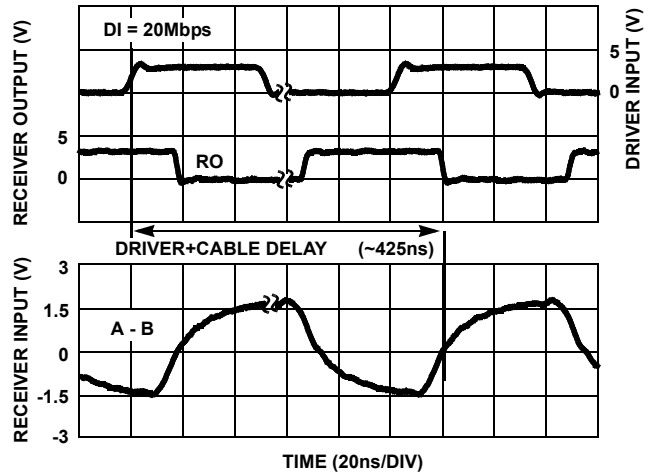
Note that receiver and driver enable times increase when these devices enable from shutdown. Refer to [Notes 8 through 12 on page 5](#) at the end of the Electrical Specification table for more information.



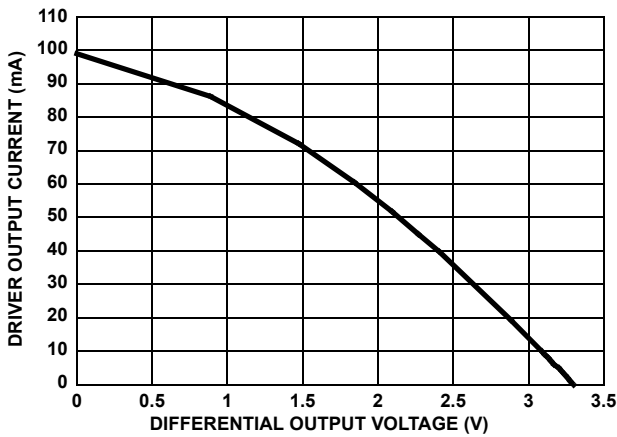
**Typical Performance Curves**  $V_{CC} = 3.3V$ ,  $T_A = +25^{\circ}C$ ; unless otherwise specified



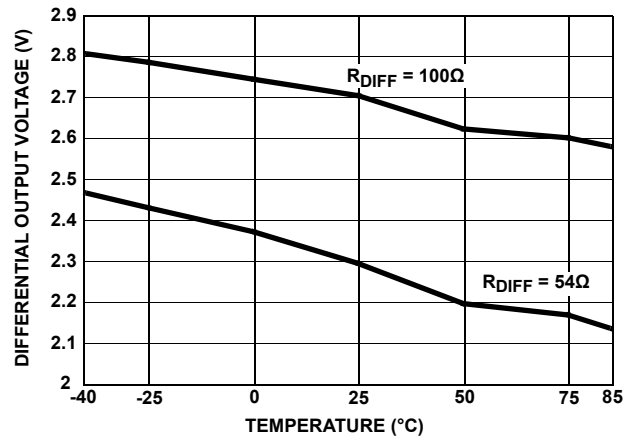
**FIGURE 6. DRIVER AND RECEIVER WAVEFORMS DRIVING 200 FEET OF CAT5 CABLE (DOUBLE TERMINATED WITH 120Ω)**



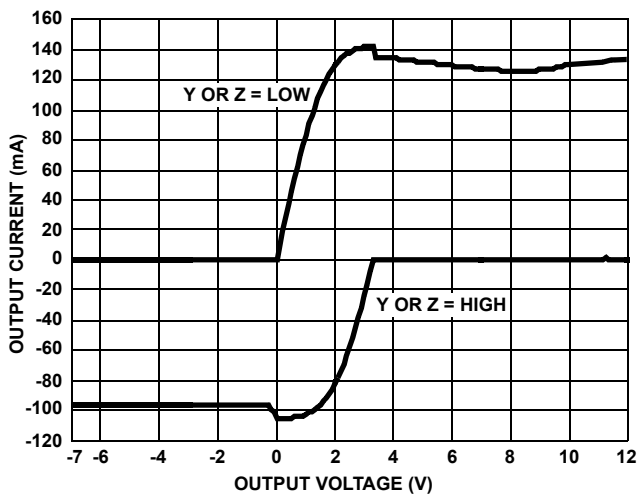
**FIGURE 7. DRIVER AND RECEIVER WAVEFORMS DRIVING 300 FEET OF CAT5 CABLE (DOUBLE TERMINATED WITH 120Ω)**



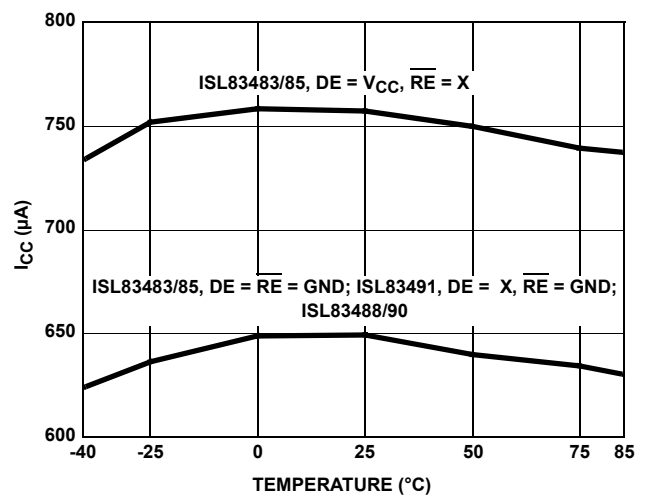
**FIGURE 8. DRIVER OUTPUT CURRENT vs DIFFERENTIAL OUTPUT VOLTAGE**



**FIGURE 9. DRIVER DIFFERENTIAL OUTPUT VOLTAGE vs TEMPERATURE**



**FIGURE 10. DRIVER OUTPUT CURRENT vs SHORT CIRCUIT VOLTAGE**



**FIGURE 11. SUPPLY CURRENT vs TEMPERATURE**

**Typical Performance Curves**  $V_{CC} = 3.3V, T_A = +25^{\circ}C$ ; unless otherwise specified (Continued)

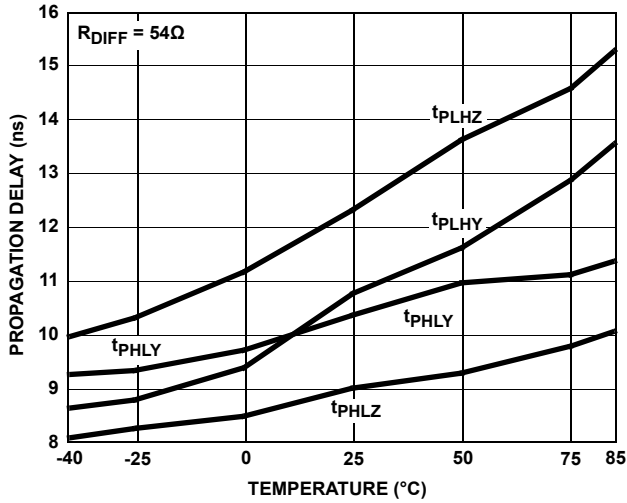


FIGURE 12. DRIVER PROPAGATION DELAY vs TEMPERATURE

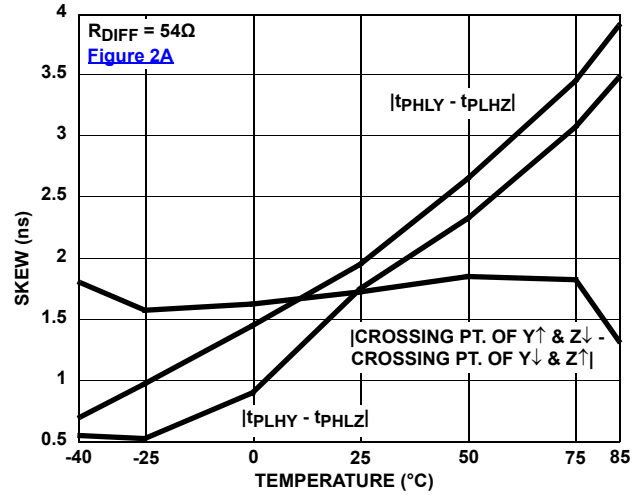


FIGURE 13. DRIVER SKEW vs TEMPERATURE

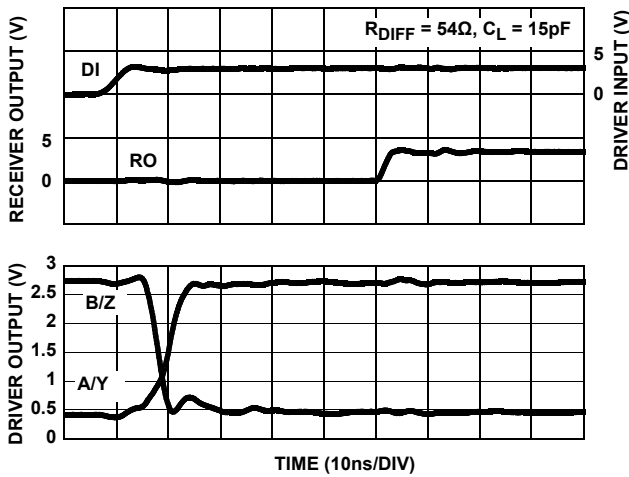


FIGURE 14. DRIVER AND RECEIVER WAVEFORMS, LOW TO HIGH

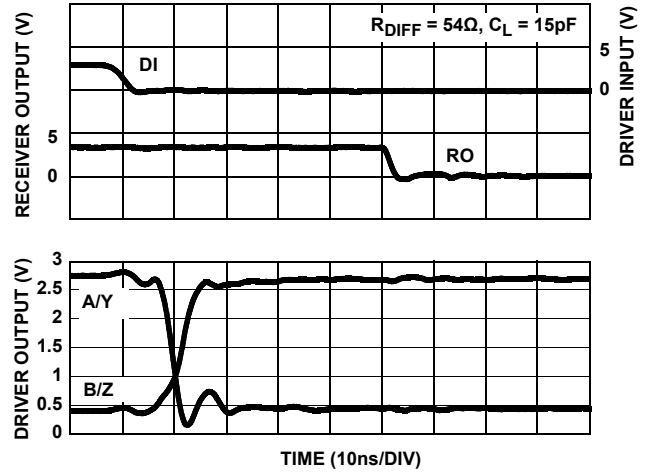


FIGURE 15. DRIVER AND RECEIVER WAVEFORMS, HIGH TO LOW

**Die Characteristics**

SUBSTRATE POTENTIAL (POWERED UP):

GND

TRANSISTOR COUNT:

528

PROCESS:

Si Gate BiCMOS

**Revision History** The revision history provided is for informational purposes only and is believed to be accurate, but not warranted. Please visit our website to make sure you have the latest revision.

DATE	REVISION	CHANGE
Sep 19, 2018	FN6071.2	<p>Added Related Literature section. Updated Typical Application drawing and moved to page 1. Updated Ordering Information table by removing retired parts, adding Notes 1 and 3, adding Part Marking column, and adding Tape and Reel column. Moved Pinouts next to Pin Descriptions. Added Revision History and updated disclaimer. Updated POD M8.15 to latest revision changes are as follows: -Remove "u" symbol from drawing (overlaps the "a" on Side View). -Updated to new POD format by removing table and moving dimensions onto drawing and adding land pattern. -Changed the following in Typical Recommended Land Pattern: 2.41(0.095) to 2.20(0.087) 0.76 (0.030) to 0.60(0.023) 0.200 to 5.20(0.205) -Changed Note 1 "1982" to "1994"</p>

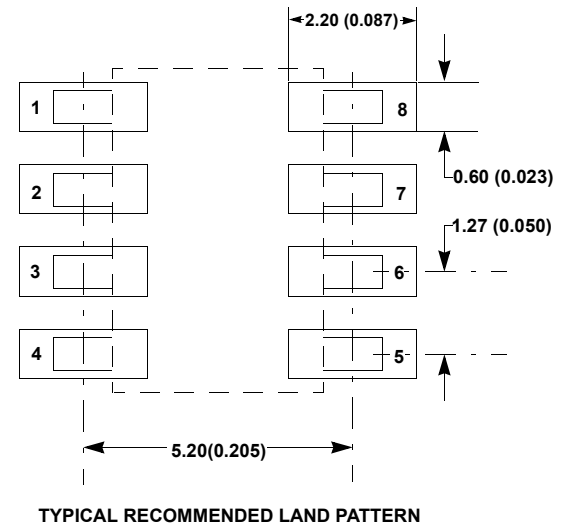
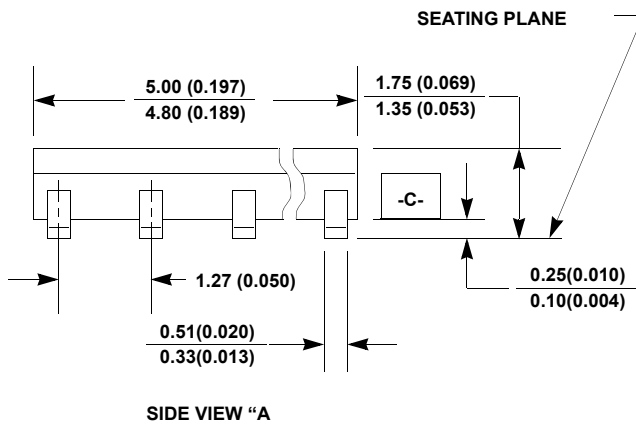
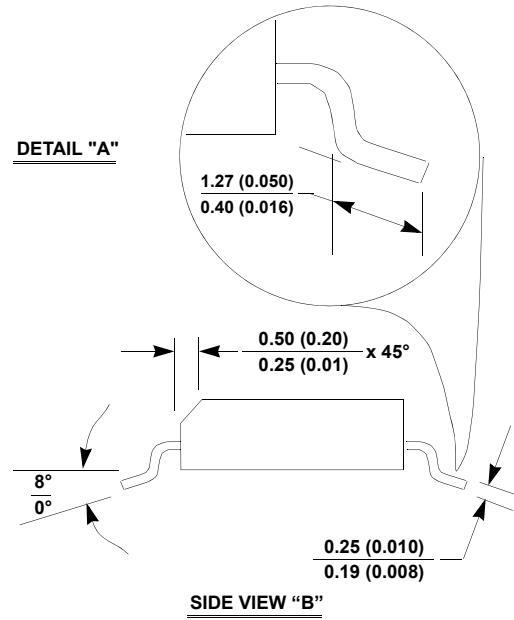
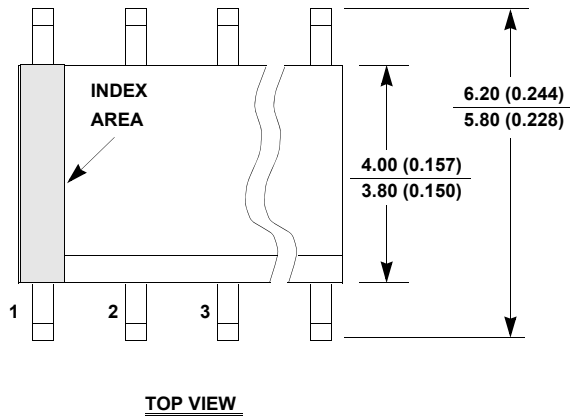
**Package Outline Drawing**

**M8.15**

**8 LEAD NARROW BODY SMALL OUTLINE PLASTIC PACKAGE**

Rev 4, 1/12

For the most recent package outline drawing, see [M8.15](#).



**NOTES:**

1. Dimensioning and tolerancing per ANSI Y14.5M-1994.
2. Package length does not include mold flash, protrusions or gate burrs. Mold flash, protrusion and gate burrs shall not exceed 0.15mm (0.006 inch) per side.
3. Package width does not include interlead flash or protrusions. Interlead flash and protrusions shall not exceed 0.25mm (0.010 inch) per side.
4. The chamfer on the body is optional. If it is not present, a visual index feature must be located within the crosshatched area.
5. Terminal numbers are shown for reference only.
6. The lead width as measured 0.36mm (0.014 inch) or greater above the seating plane, shall not exceed a maximum value of 0.61mm (0.024 inch).
7. Controlling dimension: MILLIMETER. Converted inch dimensions are not necessarily exact.
8. This outline conforms to JEDEC publication MS-012-AA ISSUE C.

## Notice

1. Descriptions of circuits, software and other related information in this document are provided only to illustrate the operation of semiconductor products and application examples. You are fully responsible for the incorporation or any other use of the circuits, software, and information in the design of your product or system. Renesas Electronics disclaims any and all liability for any losses and damages incurred by you or third parties arising from the use of these circuits, software, or information.
2. Renesas Electronics hereby expressly disclaims any warranties against and liability for infringement or any other claims involving patents, copyrights, or other intellectual property rights of third parties, by or arising from the use of Renesas Electronics products or technical information described in this document, including but not limited to, the product data, drawings, charts, programs, algorithms, and application examples.
3. No license, express, implied or otherwise, is granted hereby under any patents, copyrights or other intellectual property rights of Renesas Electronics or others.
4. You shall not alter, modify, copy, or reverse engineer any Renesas Electronics product, whether in whole or in part. Renesas Electronics disclaims any and all liability for any losses or damages incurred by you or third parties arising from such alteration, modification, copying or reverse engineering.
5. Renesas Electronics products are classified according to the following two quality grades: "Standard" and "High Quality". The intended applications for each Renesas Electronics product depends on the product's quality grade, as indicated below.  
"Standard": Computers; office equipment; communications equipment; test and measurement equipment; audio and visual equipment; home electronic appliances; machine tools; personal electronic equipment; industrial robots; etc.  
"High Quality": Transportation equipment (automobiles, trains, ships, etc.); traffic control (traffic lights); large-scale communication equipment; key financial terminal systems; safety control equipment; etc.  
Unless expressly designated as a high reliability product or a product for harsh environments in a Renesas Electronics data sheet or other Renesas Electronics document, Renesas Electronics products are not intended or authorized for use in products or systems that may pose a direct threat to human life or bodily injury (artificial life support devices or systems; surgical implantations; etc.), or may cause serious property damage (space system; undersea repeaters; nuclear power control systems; aircraft control systems; key plant systems; military equipment; etc.). Renesas Electronics disclaims any and all liability for any damages or losses incurred by you or any third parties arising from the use of any Renesas Electronics product that is inconsistent with any Renesas Electronics data sheet, user's manual or other Renesas Electronics document.
6. When using Renesas Electronics products, refer to the latest product information (data sheets, user's manuals, application notes, "General Notes for Handling and Using Semiconductor Devices" in the reliability handbook, etc.), and ensure that usage conditions are within the ranges specified by Renesas Electronics with respect to maximum ratings, operating power supply voltage range, heat dissipation characteristics, installation, etc. Renesas Electronics disclaims any and all liability for any malfunctions, failure or accident arising out of the use of Renesas Electronics products outside of such specified ranges.
7. Although Renesas Electronics endeavors to improve the quality and reliability of Renesas Electronics products, semiconductor products have specific characteristics, such as the occurrence of failure at a certain rate and malfunctions under certain use conditions. Unless designated as a high reliability product or a product for harsh environments in a Renesas Electronics data sheet or other Renesas Electronics document, Renesas Electronics products are not subject to radiation resistance design. You are responsible for implementing safety measures to guard against the possibility of bodily injury, injury or damage caused by fire, and/or danger to the public in the event of a failure or malfunction of Renesas Electronics products, such as safety design for hardware and software, including but not limited to redundancy, fire control and malfunction prevention, appropriate treatment for aging degradation or any other appropriate measures. Because the evaluation of microcomputer software alone is very difficult and impractical, you are responsible for evaluating the safety of the final products or systems manufactured by you.
8. Please contact a Renesas Electronics sales office for details as to environmental matters such as the environmental compatibility of each Renesas Electronics product. You are responsible for carefully and sufficiently investigating applicable laws and regulations that regulate the inclusion or use of controlled substances, including without limitation, the EU RoHS Directive, and using Renesas Electronics products in compliance with all these applicable laws and regulations. Renesas Electronics disclaims any and all liability for damages or losses occurring as a result of your noncompliance with applicable laws and regulations.
9. Renesas Electronics products and technologies shall not be used for or incorporated into any products or systems whose manufacture, use, or sale is prohibited under any applicable domestic or foreign laws or regulations. You shall comply with any applicable export control laws and regulations promulgated and administered by the governments of any countries asserting jurisdiction over the parties or transactions.
10. It is the responsibility of the buyer or distributor of Renesas Electronics products, or any other party who distributes, disposes of, or otherwise sells or transfers the product to a third party, to notify such third party in advance of the contents and conditions set forth in this document.
11. This document shall not be reprinted, reproduced or duplicated in any form, in whole or in part, without prior written consent of Renesas Electronics.
12. Please contact a Renesas Electronics sales office if you have any questions regarding the information contained in this document or Renesas Electronics products.

(Note 1) "Renesas Electronics" as used in this document means Renesas Electronics Corporation and also includes its directly or indirectly controlled subsidiaries.

(Note 2) "Renesas Electronics product(s)" means any product developed or manufactured by or for Renesas Electronics.

(Rev.4.0-1 November 2017)



### SALES OFFICES

Renesas Electronics Corporation

<http://www.renesas.com>

Refer to "<http://www.renesas.com>" for the latest and detailed information.

#### Renesas Electronics Corporation

TOYOSU FORESIA, 3-2-24 Toyosu, Koto-ku, Tokyo 135-0061, Japan

#### Renesas Electronics America Inc.

1001 Murphy Ranch Road, Milpitas, CA 95035, U.S.A.  
Tel: +1-408-432-8888, Fax: +1-408-434-5351

#### Renesas Electronics Canada Limited

9251 Yonge Street, Suite 8309 Richmond Hill, Ontario Canada L4C 9T3  
Tel: +1-905-237-2004

#### Renesas Electronics Europe Limited

Dukes Meadow, Millboard Road, Bourne End, Buckinghamshire, SL8 5FH, U.K  
Tel: +44-1628-651-700

#### Renesas Electronics Europe GmbH

Arcadiastrasse 10, 40472 Düsseldorf, Germany  
Tel: +49-211-6503-0, Fax: +49-211-6503-1327

#### Renesas Electronics (China) Co., Ltd.

Room 1709 Quantum Plaza, No.27 ZhichunLu, Haidian District, Beijing, 100191 P. R. China  
Tel: +86-10-8235-1155, Fax: +86-10-8235-7679

#### Renesas Electronics (Shanghai) Co., Ltd.

Unit 301, Tower A, Central Towers, 555 Langao Road, Putuo District, Shanghai, 200333 P. R. China  
Tel: +86-21-2226-0888, Fax: +86-21-2226-0999

#### Renesas Electronics Hong Kong Limited

Unit 1601-1611, 16/F., Tower 2, Grand Century Place, 193 Prince Edward Road West, Mongkok, Kowloon, Hong Kong  
Tel: +852-2265-6688, Fax: +852 2886-9022

#### Renesas Electronics Taiwan Co., Ltd.

13F, No. 363, Fu Shing North Road, Taipei 10543, Taiwan  
Tel: +886-2-8175-9600, Fax: +886 2-8175-9670

#### Renesas Electronics Singapore Pte. Ltd.

80 Bendemeer Road, Unit #06-02 Hyflux Innovation Centre, Singapore 339949  
Tel: +65-6213-0200, Fax: +65-6213-0300

#### Renesas Electronics Malaysia Sdn.Bhd.

Unit 1207, Block B, Menara Amcorp, Amcorp Trade Centre, No. 18, Jin Persiaran Barat, 46050 Petaling Jaya, Selangor Darul Ehsan, Malaysia  
Tel: +60-3-7955-9390, Fax: +60-3-7955-9510

#### Renesas Electronics India Pvt. Ltd.

No.777C, 100 Feet Road, HAL 2nd Stage, Indiranagar, Bangalore 560 038, India  
Tel: +91-80-67208700, Fax: +91-80-67208777

#### Renesas Electronics Korea Co., Ltd.

17F, KAMCO Yangjae Tower, 262, Gangnam-daero, Gangnam-gu, Seoul, 06265 Korea  
Tel: +82-2-558-3737, Fax: +82-2-558-5338