

White Paper

How to Reconfigure a Buck Converter for Multiple Outputs

Introduction

Power supply circuits come in the form of voltage step-up (boost) or the more common step-down (buck) DC/DC converter. Many of today's applications require multiple voltage rails to drive a variety of ICs. These rails can be inverting or non-inverting, with or without isolation. While designers typically use multiple buck converters with single filter inductors, they add cost, footprint and height. A simpler alternative is to use a single buck converter with coupled inductors or transformers configured in isolated converter topologies. Designers can use the buck converter for inverting or non-inverting voltage rails, and they can configure it for use as an inverting buck-boost converter. Coupled inductors or transformers can also be used with a buck-boost converter to generate multiple inverting or non-inverting outputs with voltage step up/down function.

This white paper will highlight various isolated/non-isolated DC/DC converter topologies and demonstrate how they can be implemented using a single synchronous buck converter. We'll also look at other topologies and show how they are suitable for various applications.

1. Isolated buck
 - a. +/- step-down output
 - b. +/+ step-down output
 - c. +/+/- step-down output
2. Inverting buck-boost (step-up and step-down) output
3. Isolated +/- buck-boost output

A Look at Three DC/DC Converter Topologies

The beauty of generating various converter topologies based on a single buck converter is that an opto-coupler and its related circuitry are not required. This provides the benefit of a smaller footprint, lower component count, reduced complexity and cost savings. Besides generating multiple outputs, the buck converter is configurable to operate as an inverting buck-boost converter, essentially providing a voltage step-up function. In addition, designers can create an isolated buck-boost converter using a similar concept.

1. Isolated Buck Topology

A. +/- Step-down Output: Circuit Operation

An inverting and non-inverting step-down output can be generated with an isolated buck topology. Figure 1 shows how it delivers a +/- output rail to any application that requires a positive and a negative supply.

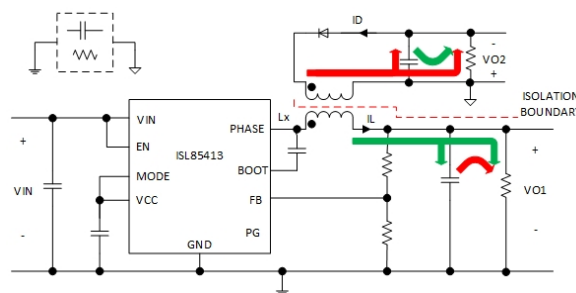

Figure 1. Synchronous buck regulator uses isolated buck topology to generate \pm Vout rail

With reference to Figure 1, the primary and secondary outputs are given by the following equations, assuming the leakage inductance of the coupled inductor or transformer and the DC resistance of the windings is negligible:

$$V_{O1} = D \times V_{IN} \quad [1]$$

$$V_{O2} = -(N \times V_{O1} - V_{diode}) \quad [2]$$

where V_{IN} is the input voltage, V_{O1} and V_{O2} are the primary and secondary outputs, respectively, D is the duty cycle, N is the turns ratio of the transformer, and V_{diode} is the forward voltage drop across the diode.

During the cycle when the high side switch is on (current flow indicated by the green arrow in Figure 1), the primary current ramps up and stores the energy in the magnetizing inductance of the transformer and the primary output capacitor. The diode on the secondary side is reverse biased and the load current on the secondary side is supplied by the output capacitor.

During the cycle when the low side switch is on (current flow indicated by the red arrow in Figure 1), the primary current ramps down and releases the stored energy in the magnetizing inductance of the transformer, and the load current on the primary side is supplied by the output capacitor. The diode on the secondary side is forward biased and the current flows from the transformer to supply current to the load, and charges up the secondary output capacitor. At steady state, the voltage at the secondary output is proportionally inverted compared to the voltage at the primary output, assuming the diode voltage drop, transformer winding resistance, and leakage inductances are negligible. Figure 2 shows the operating waveforms for the ISL85413DEMO3Z +/- output isolated buck demo board.

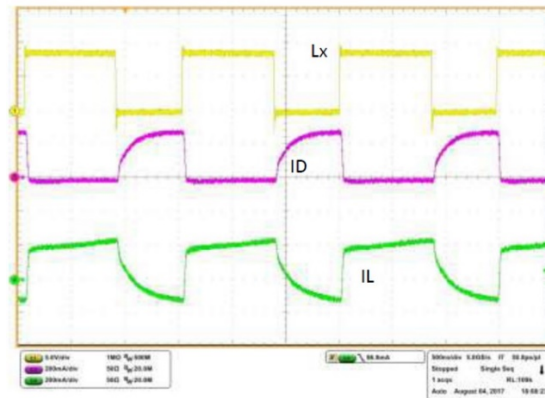

Figure 2. Operating waveforms for ISL85413DEMO3Z at $V_{IN}=9V$, $V_{O1}=V_{O2}=5V$, $I_{O1}=I_{O2}=100mA$

B. +/- step-down output

Employing the same concept of generating secondary outputs using a coupled inductor or transformer, the secondary side can be configured differently to generate positive or negative secondary voltages. To generate a positive secondary output, the polarities of the transformer/coupled inductor as well as the secondary side diode are reversed. Figure 3 shows an isolated buck topology to generate a dual +VOUT rail.

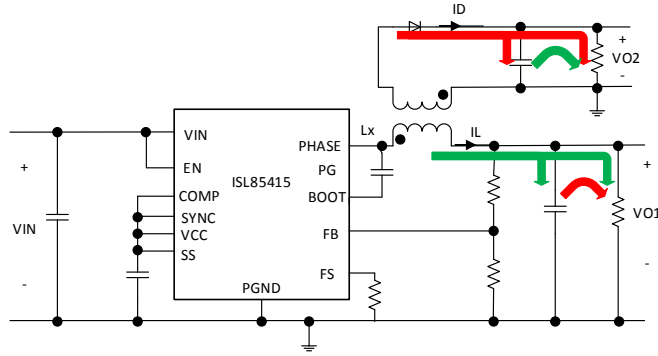

Figure 3. Isolated buck topology to generate a dual + VOUT rail (ISL85415DEMO2Z)

C. +/- step-down output

Figure 4 shows an isolated buck topology to generate three outputs (dual +VOUT and single -VOUT rail). The +/-/- isolated buck demo board ISL854102DEMO2Z can be used to demonstrate this topology. For a multiple outputs configuration, the total current of the various outputs reflected to the primary side must be accounted for to make sure the IC is able to handle the resultant current.

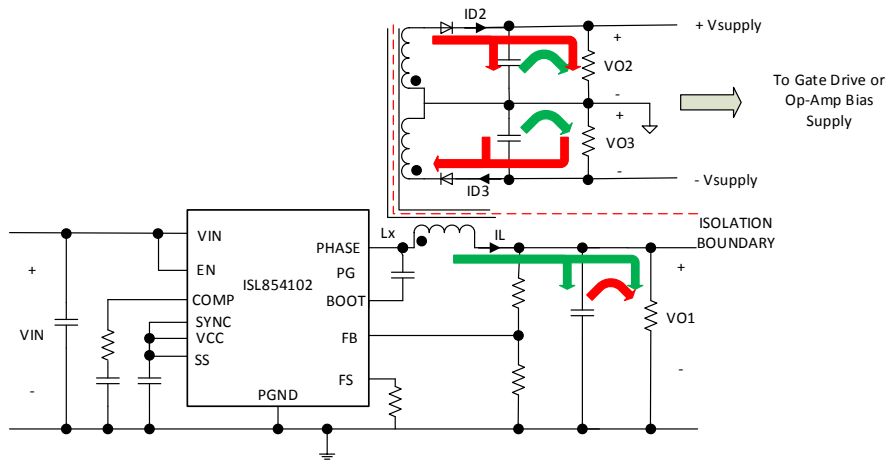

Figure 4. Isolated buck topology to generate three outputs, dual +VOUT and single -VOUT rail, (ISL854102DEMO2Z).

The equations for the above circuit are as given below:

$$V_{O1} = D \times V_{IN} \quad [3]$$

$$V_{O2} = N_1 \times V_{O1} - V_{diode} \quad [4]$$

$$V_{O3} = -(N_2 \times V_{O1} - V_{diode}) \quad [5]$$

$$\Delta i = \frac{(V_{IN} - V_{O1})}{L} \times DT_s \quad [6]$$

$$I_{DS_pk} = I_{OUT1} + \frac{\Delta i}{2} + \frac{I_{OUT2}}{N_2} + \frac{I_{OUT3}}{N_3} \quad [7]$$

Where V_{O1} is the primary output and V_{O2} and V_{O3} are the positive and negative secondary outputs, respectively, D is the duty cycle, N_1 and N_2 are the turns ratio of the transformer for V_{O2} and V_{O3} , respectively. V_{diode} is the forward voltage drop across the diode. I_{OUT1} , I_{OUT2} and I_{OUT3} are the output current drawn from V_{O1} , V_{O2} and V_{O3} , respectively, I_{DS_pk} is the peak current through the top switch and Δi is the triangular portion of the primary inductor ripple current.

2. Inverting buck-boost (step-up and step-down) Topology

An inverting buck-boost converter can be derived from the synchronous buck converter by connecting its GND terminal as the negative output of the buck-boost converter and the VOUT terminal of the buck converter as the GND of the buck-boost converter. Figure 5 shows the circuit diagram of configuring the ISL85415 buck switcher as an inverting buck-boost converter.

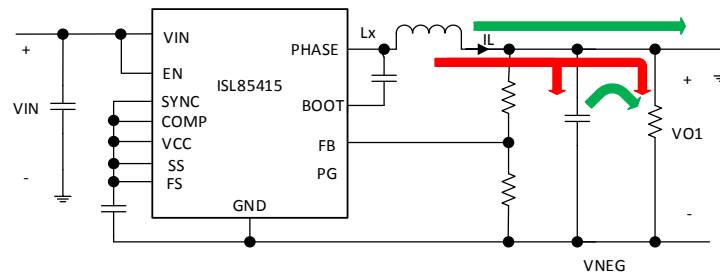

Figure 5. Configuring the ISL85415 buck converter into an inverting buck-boost converter

The equation for output voltage and output current are as follows:

$$V_{O1} = -\frac{D}{(1-D)} \times V_{IN} \quad [8]$$

$$I_{OUT} = -(1-D)I_L \quad [9]$$

where V_{IN} is the input voltage, V_{O1} is the output voltage, D is the duty cycle, I_{OUT} is the output current, and I_L is the inductor current.

During the cycle when the high side switch is on (current flow indicated by the green arrow in Figure 5), the inductor current ramps up and stores energy in the inductor and the output capacitor provides current to the load. During the cycle when the low side switch is on (current flow indicated by the red arrow in Figure 5), the inductor current ramps down and provides current to the load as well as charges the output capacitor. Operating waveforms for the ISL85415EVAL2Z inverting buck-boost board are shown in Figure 6.

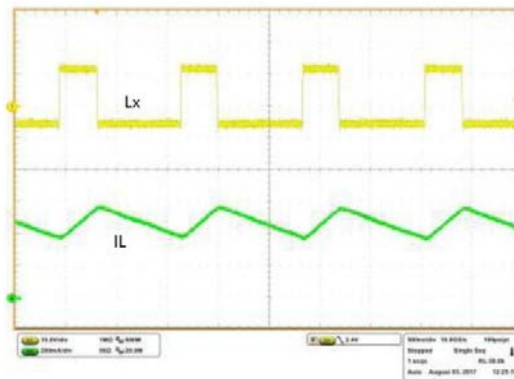

Figure 6. Operating waveforms for ISL85415EVAL2Z at $V_{IN}=12V$, $V_O=-5V$, $I_O=-300mA$

3. Isolated buck-boost Topology: +/- output

A \pm step up/down output voltage can be realized using the isolated buck-boost topology. The filter inductor can be replaced with a transformer (or coupled inductor) to obtain a positive secondary output. Figure 7 shows an isolated buck-boost topology to generate a \pm step up/down V_{OUT} rail. Figure 8 shows the operating waveforms for ISL854102DEMO3Z isolated buck-boost regulator board.

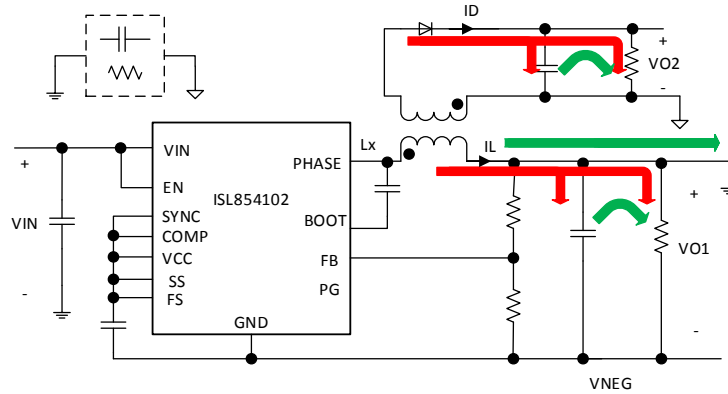

Figure 7. Isolated buck-boost topology to generate a \pm V_{OUT} rail.

The voltage and current equations for the above circuit are given below:

$$V_{O2} = \frac{-D \times N}{(1-D)} \times V_{IN} - V_{diode} \quad [10]$$

$$I_{DS, pk} = \frac{I_{OUT1} + I_{OUT2}/N}{1-D} + \frac{\Delta i}{2} \quad [11]$$

where V_{IN} is the input voltage, V_{O2} is the secondary output voltage, V_{diode} is the forward voltage drop across the diode, D is the duty cycle, N is the turns ratio of the transformer, $I_{DS, pk}$ is the peak current through the top switch, Δi is the triangular portion of the primary inductor ripple current, and I_{OUT1} and I_{OUT2} are the output current drawn from V_{O1} and V_{O2} , respectively.

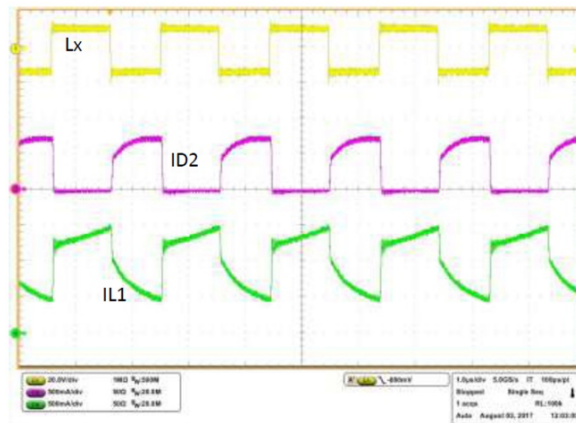

Figure 8. Operating waveforms for ISL854102DEMO3Z at $V_{IN}=24V$, $V_{O1}=V_{O2}=5V$, $I_{O1}=500mA$, $I_{O2}=500mA$.

Other Possible Isolated Buck Converter Configurations

Stacked Positive Output

In Figure 3, we demonstrated a dual positive output topology. To generate a voltage doubler, or two different positive voltages, the negative terminal of the secondary output can be connected to the positive primary output as illustrated in Figure 9.

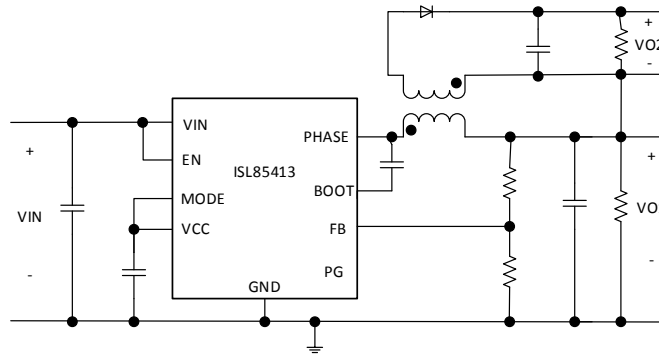

Figure 9. Stacked positive output converter topology

Dual regulated and single unregulated positive output

A low dropout (LDO) regulator can be used to generate a dual regulated output. Figure 10 shows the configuration for generating a dual regulated and a single unregulated positive output. In this configuration, the output from the secondary side is regulated by connecting the secondary output to the feedback via a resistor divider. The primary output is regulated using an LDO.

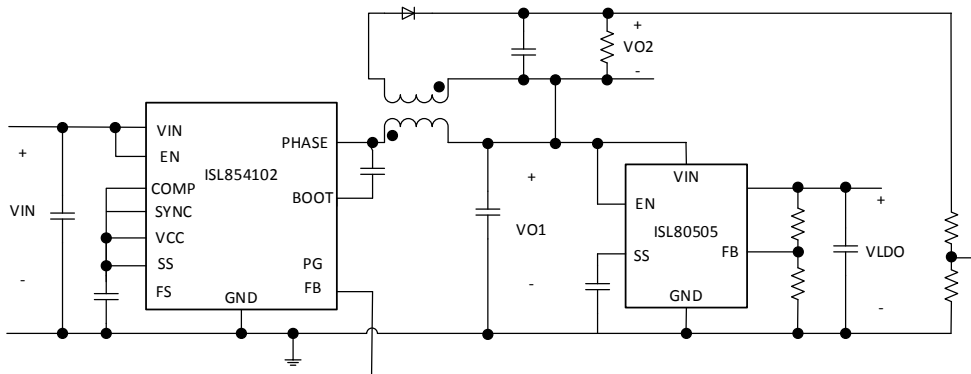

Figure 10. Dual regulated output using additional LDO

Applications for Isolated Topologies or Other Buck Converter Configurations

Galvanic isolation and multiple output applications are common in various power electronics applications, such as telecommunications, industrial programmable logic controllers (PLCs), industrial factory automation, isolated communication interfaces (i.e. RS-485, RS-232), bias supplies for gate drives, sensors, op amps, motor drive applications and any application that requires positive and negative rails. This section highlights several applications, and explains how to employ the various topologies.

1. Amplifier Power Supply

Dual supply amplifiers are more common due to their higher efficiency and requirement to produce the replica of the input waveform without incurring DC losses. Figure 11A shows an audio amplifier with $\pm 12V$ rail, and Figure 11B shows an operational amplifier (op amp) with $\pm 5V$ rail.

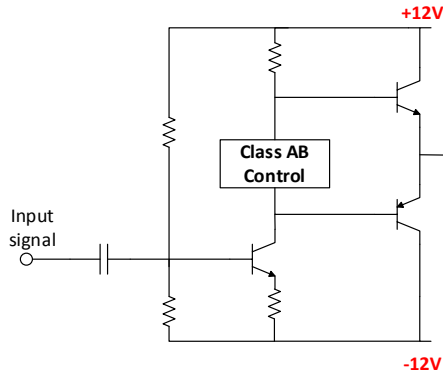

Figure 11A: Audio amplifier with $\pm 12V$ rail

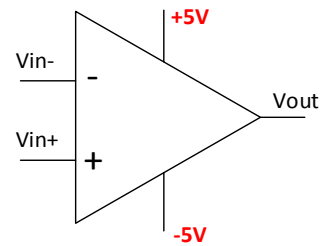

Figure 11B: Op amp with $\pm 5V$ rail

The input voltage is considered when selecting the appropriate topology for these applications. For instance to power an audio amplifier operating on $\pm 12V$ rails, if the input power rail is 24V, an isolated buck topology is selected. If a 12V battery is used, an inverting buck-boost topology can be used to generate the negative rail. If a 5V USB, 12V battery or green energy powered system is used, an isolated buck-boost topology should be used. Figure 12 illustrates using the various topologies to supply power to an audio amplifier.

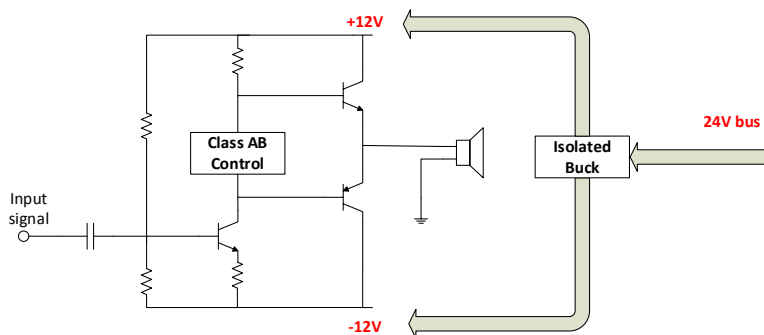

Figure 12A. Using an isolated buck topology for input supply of 24V

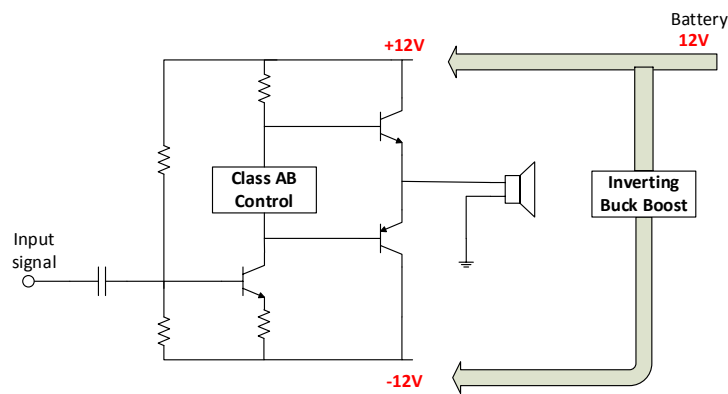

Figure 12B. Using inverting buck-boost to generate negative rail when input supply is a 12V battery

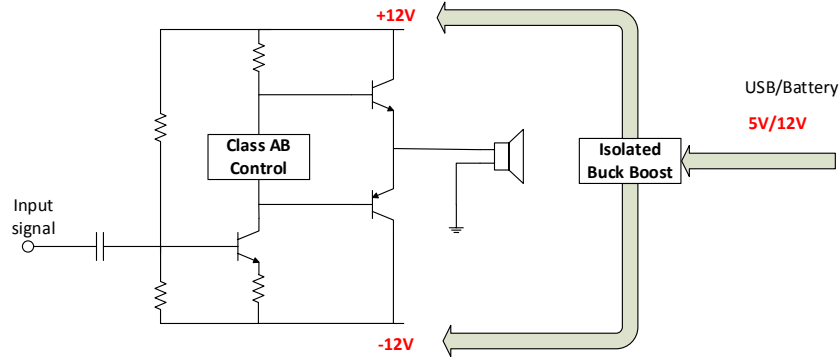

Figure 12C. Using an isolated buck-boost topology when input supply is 5V USB or 12V battery

Similarly, for some of the following applications, which require both a positive and negative rail, the three topologies shown in Figures 12A, 12B and 12C can be used depending on the input rail.

2. IGBT Gate Drive Bias

Isolated gate drivers are typically used for high power inverter applications, including UPS systems, motor control, high intensity discharge (HID) lamp ballast and induction heating. Other applications include variable speed AC and DC drives, industrial/solar inverters and servo drives. Figure 13 shows an illustration of a three-phase inverter with IGBT gate drive bias using isolated buck.

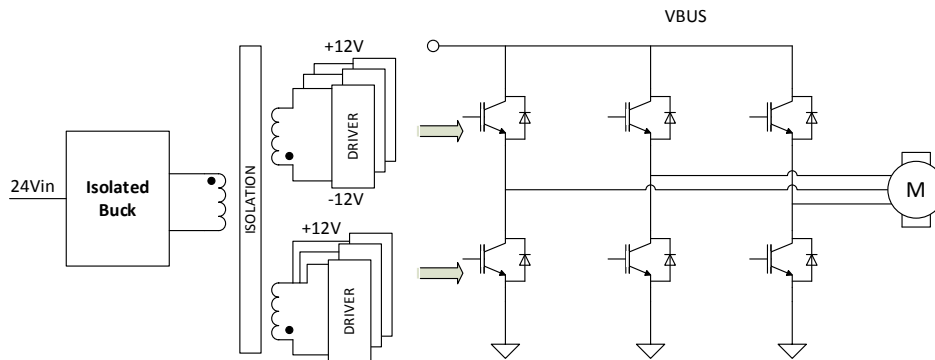

Figure 13. Three-phase inverter with isolated IGBT gate drive bias using isolated buck

3. Line Drivers, Receiver/Translator/Buffer using Various Interface Standards

Various interface standards are used in today's telecommunication and data communication systems. Examples include emitter-coupled logic (ECL), common mode logic (CML), low-voltage differential signaling (LVDS), which are used in graphics display interfaces, and mobile/server chipsets for communication, consumer, and mobile applications. Devices like fanout buffers, clock drivers and receivers often require both inverting and non-inverting supply rails.

Line drivers are electronic amplifier circuits designed to drive a load, such as a transmission line. Differential signaling circuits are often used as they are more resistant to noise, are more capable of more reliably carrying high bit rate signals, and hence they require a non-inverting and inverting power rail.

Figure 14 shows the block diagram of a LVDS/PECL driver to CML receiver Interface.

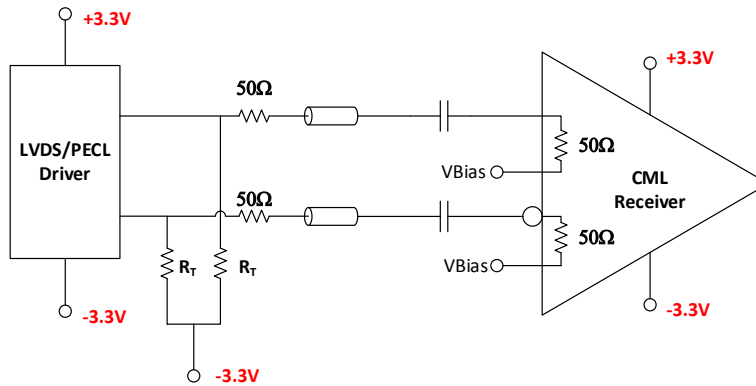

Figure 14. LVDS/PECL driver to CML receiver interface block diagram

4. Industrial Automation System

Programmable logic controllers (PLCs) are often used in industrial automation systems for controlling the manufacturing process. PLC comprises several hardware system components, which require different power supply rails. Figure 15 shows the power supply tree to the various hardware blocks of a PLC.

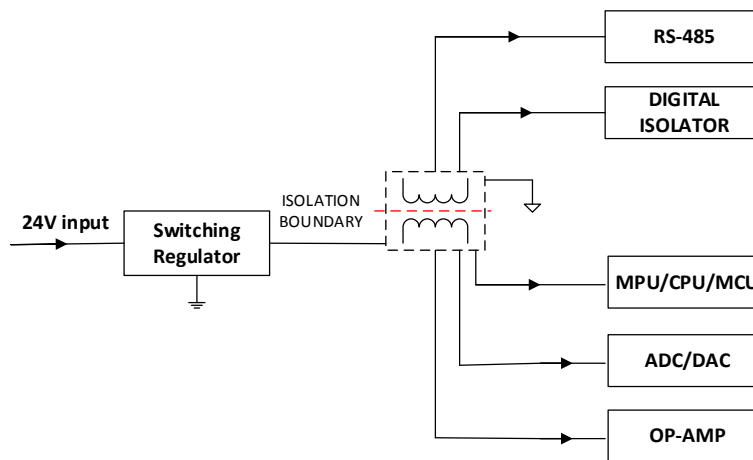

Figure 15. Power supply tree to the various hardware blocks of a PLC

Summary of Applications

As discussed in the previous sections, designers can select different topologies to provide the power supply rails for various applications, depending on the level of the input voltage rail. Table 1 summarizes the suitable topology for the various applications.

	isolated buck			inverting buck-boost	isolated buck-boost
Output voltage polarity	±	+, +	+, ±	-	±
Operational amplifier/ Audio amplifier	X			X	X
IGBT gate drive bias	X		X		X
Line drivers, receiver/translator/buffer	X				X
Industrial Automation System		X			

Table 1. Summary of suitable topology for various applications

Conclusion

In this paper, we have demonstrated how to use a synchronous buck converter to generate multiple outputs as well as inverting outputs through different circuit configurations. Suitable applications have also been suggested for the various topologies. Using a single synchronous buck converter in place of different types of converters simplifies power design for both novice and expert power-supply designers. It also reduces solution footprint, circuit complexity, as well as BOM cost and time to market.

Next Steps

- [Learn more about DC-DC converters](#)
- [Download the ISL85413 datasheet](#)
- [Download the ISL85415 datasheet](#)
- [Download the ISL854102 datasheet](#)

#

About Renesas Electronics Corporation

Renesas Electronics Corporation delivers trusted embedded design innovation with complete semiconductor solutions that enable billions of connected, intelligent devices to enhance the way people work and live—securely and safely. A global leader in microcontrollers, analog, power, and SoC products, Renesas provides the expertise, quality, and comprehensive solutions for a broad range of Automotive, Industrial, Home Electronics, Office Automation and Information Communication Technology applications to help shape a limitless future. Learn more at [renesas.com](https://www.renesas.com)

+1 408-432-8888 | © Renesas Electronics America. All rights reserved. Renesas (and design) are trademarks owned by Renesas Electronics Corporation or one of its subsidiaries. All other trademarks mentioned are the property of their respective owners.