

White Paper

How to Monitor Sensor Health with Instrumentation Amplifiers

Introduction

Many industrial and medical applications use instrumentation amplifiers (INAs) to condition small signals in the presence of large common-mode voltages and DC potentials. The three op amp INA architecture performs this function with the input stage providing a high input impedance while the output stage filters out the common mode voltage and delivers the differential voltage. High impedance coupled with high common-mode rejection is the key to many sensor and biometric applications including flow sensors, temperature sensors, weigh scales, electrocardiogram (ECG) and blood glucose meters.

This white paper discusses the basics of a three op amp INA and examines the advantages of zero-drift amplifiers, RFI input filters, monitoring sensor health and programmable gain amplifiers. We also review application examples for a sensor health monitor and an active shield guard drive.

Three Op Amp INA Basics

By their very nature, INAs are a good choice to condition small signals. Their high impedance coupled with high common-mode rejection is ideal for sensor applications. The high input impedance is achieved by using the non-inverting inputs of the input stage, without having to resort to any feedback tricks. The three op amp circuit strips off the common-mode voltage and amplifies the sensor signal with very little error. However, the input common mode voltage (V_{CM}) and the differential voltages (V_D) must be taken into account to avoid saturating the INA's input stage.

A saturated input stage could appear normal to the processing circuitry, yet have disastrous consequences. Providing maximum design margin by using amplifiers with rail-to-rail input and output (RRIO) configurations will help you avoid saturating the input stage. The following discussion gives the basic operation of the three op amp INA and illustrates how the amplifier handles both common mode and differential signals.

Figure 1 shows the block diagram of a three op amp INA. By design, the inputs are subdivided into a common-mode voltage, V_{CM} , and a differential voltage V_D . Where: V_{CM} is defined as the voltage common to both inputs and is the average of the sum of INA_+ and INA_- , V_D is defined as the net difference of INA_+ and INA_- (see Equation 1).

$$V_{CM} = \frac{(INA_+ + INA_-)}{2} \quad \text{and} \quad V_D = INA_+ - INA_- \quad \text{EQ.1}$$

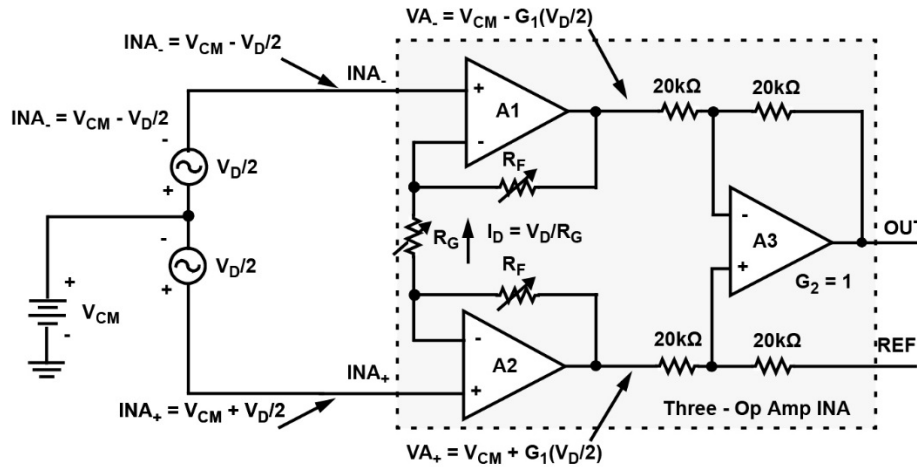

Figure 1. Block diagram of a three op amp INA with voltage nodes

The node voltages on the input pins of the INA (INA_+ , INA_-), as a result of applying a common mode voltage and differential voltage, are given in Equation 2.

$$INA_+ = V_{CM} + \frac{V_D}{2} \quad \text{and} \quad INA_- = V_{CM} - \frac{V_D}{2} \quad \text{EQ.2}$$

In the non-saturated mode, the op amp action of A1 and A2 applies the differential voltage across the gain setting resistor, R_G , generating a current I_D :

$$I_D = \frac{(INA_+ + INA_-)}{R_G} = \frac{V_D}{R_G} \quad \text{EQ.3}$$

The output voltages of A1 and A2 are therefore:

$$VA_+ = V_{CM} + \frac{V_D}{2} + I_D R_F \quad \text{and} \quad VA_- = V_{CM} - \frac{V_D}{2} - I_D R_F \quad \text{EQ.4}$$

Substituting EQ.3 into EQ.4 yields:

$$VA_+ = V_{CM} + \frac{V_D}{2} G_1 \quad \text{and} \quad VA_- = V_{CM} - \frac{V_D}{2} G_1 \quad \text{EQ.5}$$

where $G_1 = 1 + 2 \frac{R_F}{R_G}$

Equation 5 only shows the differential component $V_D/2$ amplified by the gain G_1 , while the common-mode voltage V_{CM} passes the input stage with unity gain and is subsequently cancelled out by the common mode rejection of amplifier A3. This action enables the INA to remove common mode signals from the desired differential signal, which is exactly the result you want. Frequently, the differential signal from various sensors is amplified 100 to 1000 times to get the sensitivity required from the measurement. Examples include precision weigh scales, medical instruments, Wheatstone bridges and thermopile sensors, to name a few.

Advantages of Zero-Drift Amplifiers

The input offset voltage of all amplifiers, regardless of process technology and architecture, will vary over temperature and time. Manufacturers specify input offset drift over temperature in terms of volts per degree Celsius. Traditional amplifiers will spec this limit several microvolts to tens of microvolts per degree Celsius. This offset drift can be problematic in high precision applications and cannot be calibrated out during initial manufacturing. In addition to drift over temperature, an amplifier's input offset voltage can drift over time and can create significant errors over the life of the product. For obvious reasons, this drift is not specified in the datasheets.

Zero-drift amplifiers inherently minimize both the drift over temperature and time by continually self-correcting the offset voltage. Some zero-drift amplifiers correct the offset as much as 10,000 times a second. Input offset voltage (VOS) is a critical parameter and a source of DC error encountered when using INAs to measure sensor signals. Zero-drift amplifiers, like the Intersil ISL2853x and ISL2863x, can deliver offset drift as low as 5nV/C.

Zero-drift amplifiers also eliminate 1/f noise, or flicker noise (see Figure 2). 1/f noise is a low frequency phenomenon caused by irregularities in the conduction path and noise due to the currents within the transistors. This makes zero-drift amplifiers ideal for low frequency input signals near DC, such as outputs from strain gauges, pressure sensors and thermocouples. Consider that the zero-drift amplifier's sample-and-hold function turns it into a sampled-data system, making it prone to aliasing and fold-back effects due to subtraction errors, which cause the wideband components to fold back into the baseband. However, at low frequencies, noise changes slowly, so the subtraction of the two consecutive noise samples results in true cancellation.

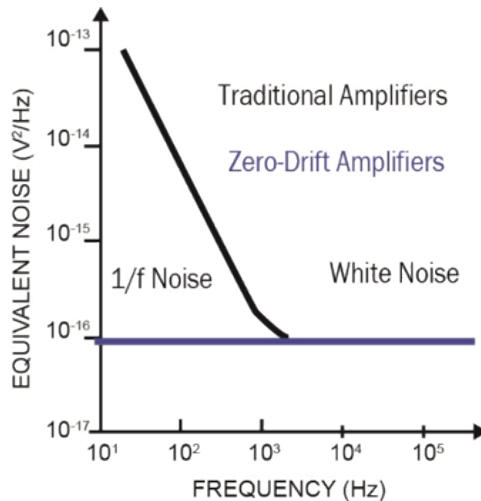

Figure 2. Noise density in semiconductors: 1/f noise to white noise

Importance of RFI Input Filters

The proliferation of wireless transceivers in portable applications has led to increased attention to an electronic circuit's ability to operate near high frequency radio transmitters such as Bluetooth. As a result, RF suppression is needed to ensure interference-free operation of the sensor.

In EMI sensitive applications, the high frequency RF signal can appear as a rectified DC offset at the output of precision amplifiers. Because the gain of the precision front end can be 100 or greater, it is critical not to

amplify any conducted or radiated noise that may be present at the amplifier inputs. An easy solution to this problem is to include RFI filters on the inputs of the INA, as shown in Figure 3.

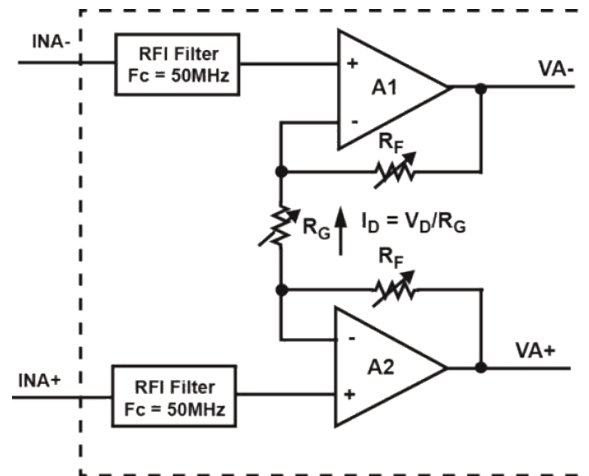

Figure 3. Input stage of an INA with RFI input filters

Monitoring of Sensor Health

The ability to monitor any changes to the sensor over time can help with the robustness and accuracy of the measurement system. Direct measurements across the sensor will more than likely corrupt the readings. A solution is to use the INA's input amplifiers as a high impedance buffer. The ISL2853x and ISL2863x instrumentation amplifiers give the user access to the output of the input amplifiers for just this purpose. VA+ is referenced to the non-inverting input of the difference amplifier while VA- is referenced to the inverting input. These buffered pins can be used for measuring the input common mode voltage for sensor feedback and health monitoring. By tying two resistors across VA+ and VA-, the buffered input common mode voltage is extracted at the midpoint of the resistors (see Figure 4). This voltage can be sent to an analog-to-digital converter (ADC) for sensor monitoring or feedback control, thus improving the sensor's precision and accuracy over time.

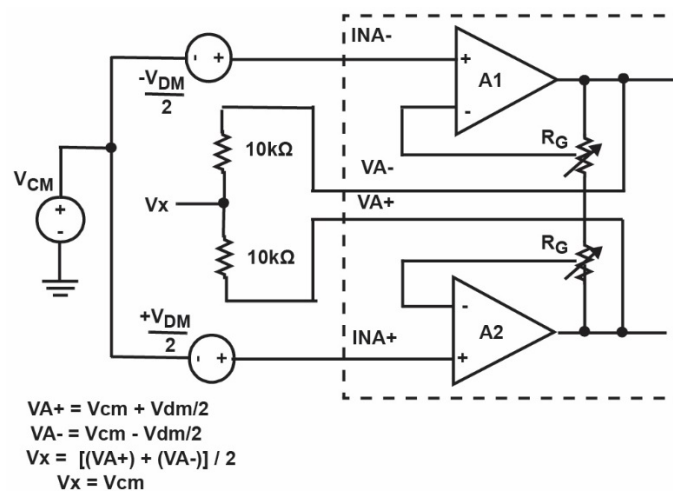

Figure 4. VA+ and VA- pins giving access to the output of the input gain stage

Advantages of a Programmable Gain Amplifier

It is widely accepted that you cannot build a precision differential amplifier using discrete parts and obtain good CMR performance or gain accuracy. This is due to the matching of the four external resistors used to configure the op amp into a differential amplifier. Further analysis shows that resistor tolerances can cause the CMR to range from as high as the limits of the op amp to as low as -24.17Db².

While integrated solutions improve on-chip resistor matching, there remains a problem with absolute matching to the external resistors used to set amplifier gain. This is because the tolerance between on-chip precision resistor values and external resistor values can vary by up to 30%. Another source of error is the difference in thermal performance between internal and external resistors; it is possible for the internal and external resistors to have opposite temperature coefficients.

A programmable gain amplifier (PGA) solves this problem by having all the resistors on board. The gain error for this type of amplifier (see Equation 6) can be less than 1%, while offering typical trim capabilities of the order of ±0.05% and ±0.4% maximum across temperature.

$$Gain_{ERROR} = \frac{(Gain_{expected} - Gain_{measured})}{Gain_{measured}} \quad \text{EQ.6}$$

Intersil's ISL2853x and ISL2863x family of PGAs offers both single ended (ISL2853x) and differential (ISL2863x) outputs with three different gain sets. Each gain set has nine different gain settings, as shown in Table 1. The gain sets were determined for specific applications in mind and are shown at the bottom of each column.

Table 1. Programmable Gain Values

PRODUCTS	ISL28533 ISL28633	ISL28534 ISL28634	ISL28535 ISL28635
GAINS	1	1	1
	2	2	100
	4	10	120
	5	50	150
	10	100	180
	20	200	200
	40	300	300
	50	500	500
	100	1000	1000
APPLICATIONS	MEDICAL PIEZO-ELECTRIC PRESSURE SENSOR FLUID SENSOR	SHUNT SENSE OPTICAL SENSORS STRAIN GAUGE THERMOCOUPLE	STRAIN GAUGE

Application Examples: Sensor Health Monitor and Active Shield Drive

Sensor Health Monitor

A bridge type sensor uses four matched resistive elements to create a balanced differential circuit. The bridge can be a combination of discrete resistors and resistive sensors for quarter-, half- and full-bridge applications. The bridge is driven by a low noise, high accuracy voltage reference on two legs. The other two

legs are the differential signal whose output voltage change is analogous to changes in the sensed environment.

In a bridge circuit, the differential signal's common mode voltage is the 'midpoint' potential voltage of the bridge excitation source. For example, in a single supply system using a +5V reference for excitation, the common mode voltage is +2.5V.

The concept of sensor health monitoring is to keep track of the bridge impedance within the data acquisition system. Changes in the environment, degradation over time or a faulty bridge resistive element will imbalance the bridge, causing measurement errors. Since the bridge differential output common mode voltage is half the excitation voltage, you can measure this common mode voltage to monitor the sensor's impedance health (see Figure 5). By periodically monitoring the common mode voltage of the bridge, you can get an indication of the sensor's health.

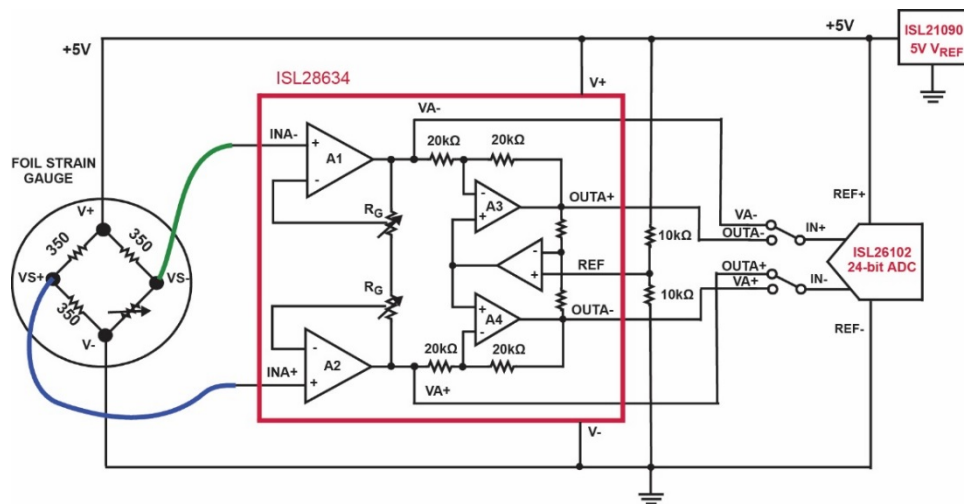

Figure 5. Sensor health monitor application schematic

Active Shield Guard Drive

Sensors that operate at far distances from the signal conditioning circuits are subject to noise environments that reduce the signal-to-noise ratio into an amplifier. Differential signaling and shielded cables are a few techniques used to reduce noise from sensitive signal lines. Reducing the noise that the instrumentation amplifier cannot reject (high frequency noise or common mode voltage levels beyond supply rail) improves measuring accuracy. Shielded cables offer excellent rejection of noise coupling into signal lines. However, cable impedance mismatch can result in a common mode error into the amplifier. Driving the cable shield to a low impedance potential reduces the impedance mismatch. The cable shield is usually tied to chassis ground as it makes an excellent low impedance point and is easily accessible. This works great for dual supply applications, but this may not always be the best potential voltage to tie the shield to for single supply amplifiers.

In certain data acquisition systems, the sensor signal amplifiers are powered with dual supplies ($\pm 2.5V$). Tying the shield to analog ground (0V) places the shield's common mode voltage right at the middle of the supply bias, which is where the amplifiers operate with the best CMR performance. With single supply amplifiers (5V) becoming a more popular choice for a sensor amplifier, tying the shield at 0V is now at the amplifier's lower power supply rail, which is typically a common mode voltage where the same CMR performance degrades. Tying the shield at common mode voltage of mid supply results in the operation of the amplifier with the best CMR performance.

An alternative solution for an improved shield guard drive is to use the VA+ and VA- pins of the ISL2853x and ISL2863x for sensing common mode and driving the shield to this voltage (see Figure 6). Using the VA+ and VA- pins generates a low impedance reference of the input common mode voltage. Driving the shield to the input common mode voltage reduces cable impedance mismatch and improves CMR performance in single supply sensor applications. For further buffering of the shield driver, the additional unused op amp on the ISL2853x products can be used, reducing the need for adding an external amplifier.

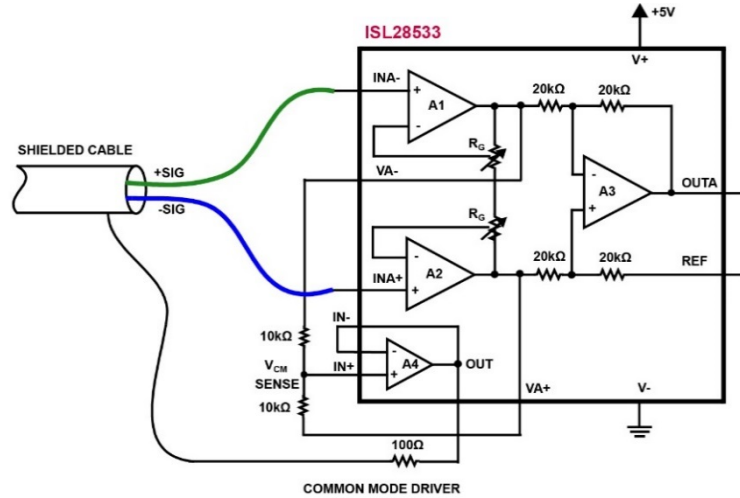

Figure 6. Active shield application schematic

Conclusion

Instrumentation amplifiers are the circuit of choice for many sensor applications. The choice of the proper amplifier is as vast as the different sensors being measured. Many advantages have been incorporated in the newer INAs on the market. As always, you'll want to choose between performance and price to select the right amplifier. If the application is for a high precision INA, then the ISL2853x and ISL2863x could be the ideal solution.

The ISL2853x/63x zero-drift amplifiers feature rail-to-rail input and output for maximum dynamic range. They also provide auto offset voltage correction and noise reduction, delivering very low offset voltage drift of $5\text{nV}/^\circ\text{C}$ and a low $1/f$ noise frequency corner down in the sub Hz range. The inputs have RFI input filters for EMI sensitive applications and they integrate precision matched resistors for the front gain stage and the differential second stage, providing very low gain error ($\pm 0.05\%$) and excellent CMR (138dB).

The ISL2853x/63x amplifiers' precision performance makes them ideal for analog sensor front end, instrumentation and data acquisition applications such as weigh scales, flow sensors and shunt current sensing that require very low noise and high dynamic range.

Next Steps

- [Learn more about the ISL2853x/63x](#)
- [Get the ISL2853x/63x PGIA datasheet](#)
- [Order the ISL2853x_63xEV2Z eval board](#)

###

About Renesas Electronics Corporation

Renesas Electronics Corporation delivers trusted embedded design innovation with complete semiconductor solutions that enable billions of connected, intelligent devices to enhance the way people work and live—securely and safely. A global leader in microcontrollers, analog, power, and SoC products, Renesas provides the expertise, quality, and comprehensive solutions for a broad range of Automotive, Industrial, Home Electronics, Office Automation and Information Communication Technology applications to help shape a limitless future. Learn more at [renesas.com](https://www.renesas.com)

+1 408-432-8888 | © Renesas Electronics America. All rights reserved. Renesas (and design) are trademarks owned by Renesas Electronics Corporation or one of its subsidiaries. All other trademarks mentioned are the property of their respective owners.