

White Paper

Achieving Satellite Mission Assurance with Rad Hard Multiplexers

Introduction

Analog multiplexers are a staple for most signal processing applications, especially satellite systems. Microprocessors have a limited number of input/output (I/O) channels and thus use a multiplexer's multiple switching inputs to sense voltage supplies and telemetry signals from a variety of sensors. As simple as they may seem in concept, there is a lot that goes on inside a multiplexer to make them reliable for space flight applications. Any integrated circuit (IC) aboard a satellite will be exposed to total ionizing dose (TID) and single-event effects (SEE). Both of these phenomena can have adverse effects on semiconductors, if not properly handled.

This article analyzes the effects of radiation on analog multiplexers by breaking down its three different sections—level shifters for the digital inputs, and decoder and switches for each I/O channel. We also examine how SEE can affect the behavior of an analog multiplexer, and present the options for overcoming the variety of radiation effects encountered during satellite missions.

Radiation Effects

The level shifter converts the logic-level voltages externally applied to the address pins/enable pin into the internal logic level voltages that drive the decoder, which in turn controls which switch to turn on (see Figure 1). If any of these sections are affected by radiation, the multiplexer's performance will be degraded. SEE and TID affect the multiplexer in very different ways, so let's look at SEE first. Single-event effects is a collective term for the various ways high-energy particles can interact with an IC.

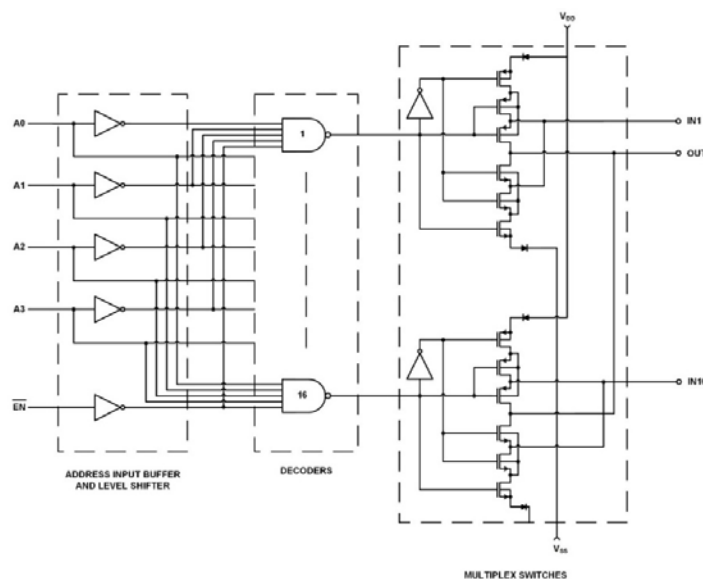

Figure 1. ISL71840SEH 16-channel multiplexer block diagram

SEE can be divided into destructive and nondestructive phenomena. Destructive effects include latch-up, burnout and MOS gate oxide rupture, which can lead to permanent damage, nonfunctional parts, and possible mission failure. Single-event latch-up (SEL) is usually reversed with a power cycle, but it may lead to immediate or latent damage. Single-event burnout is a form of SEL and causes permanent damage to the part. Nondestructive effects include bit flips and transients on the outputs of analog functions.

For logic devices, a logic state change due to a high-energy particle is called a single-event upset (SEU). A temporary glitch from which the multiplexer is able to recover with time is termed a single-event transient (SET). There are many more single-event effects but from an application standpoint, the phenomena described here are the primary concerns for analog multiplexers. Figure 2 shows an ISL71840SEH 16-channel multiplexer test plot of an SET for linear energy transfer (LET).

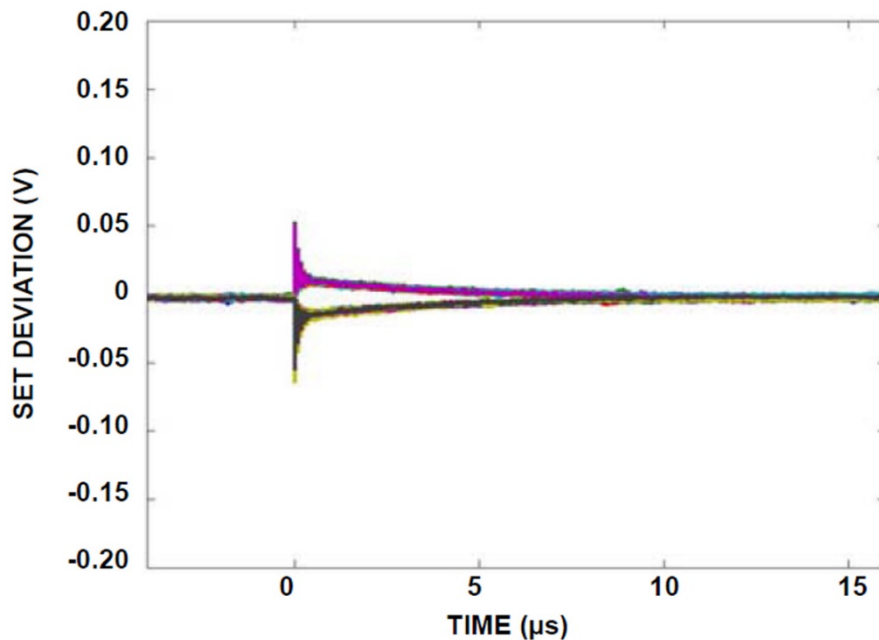

Figure 2: Composite plot of SET for LET = 43MeV•cm²/mg in test with ±10.8V supplies

Behavior of Multiplexers Exposed to Radiation

Now let's look at how each of these effects can affect the behavior of an analog multiplexer. If a high-energy particle were to strike the level shifter portion of the multiplexer, it could cause shoot-through current, which may lead to a single-event burnout (SEB) or single-event latch-up if it's not mitigated correctly during the IC design phase. A strike in the decoder section may cause a momentary change to the selected switch channel being monitored. For example, even when channel 5 is addressed, channel 6 might turn on for a brief moment before recovering to normal operation.

If a particle hits one of the off switches, a conduction path is created between two of the inputs for the duration of the transient. All of these scenarios are potentially bad, and one could argue that the last scenario is the worst. The first two scenarios only affect the multiplexer, while the last one could potentially damage the sensors attached to the inputs.

Total ionizing dose is a cumulative effect and takes more exposure time (relative to SEE) to affect an IC. On a basic level, TID affects CMOS devices by generating trapped charge in the part's oxide layers. When an ionizing particle or photon travels through the device, it generates electron-hole pairs along its path. Since

electrons have a very high oxide mobility, they are swept out of the oxide quickly by any applied electric fields. The hole mobility is much less, so a much greater proportion of holes get trapped leading to a net positive charge in the oxide layer. The trapped charge can alter the thresholds of CMOS devices. For example, the NMOS threshold voltage decreases and the PMOS threshold voltage increases. These threshold shifts can be devastating to an analog multiplexer.

Generally, the amount of threshold voltage movement relates to the thickness of the gate oxide, and devices with thicker gate oxides will shift more with radiation exposure. Herein lies the challenge in radiation hardening an analog multiplexer. A thicker gate oxide is needed for higher voltage multiplexers, but making the oxide thicker inherently makes it less tolerant to total ionizing dose. An analog multiplexer relies on digital control to select the right switch, so with prolonged TID exposure times, the threshold voltages can shift and cause the decoder to stop working, which effectively results in a nonfunctional part.

On the other side, if the thresholds on the switch devices shift, a selected channel may turn off. With multiplexers employing CMOS switches for full rail-to-rail operation, the PMOS switch could stop working due to threshold shift and lose the positive range of the common mode voltage swing. The NMOS threshold could also shift to the point that the multiplexer stays on all the time regardless of whether the decoder is selecting a particular channel to be active.

Safeguarding Satellites

Satellites typically cost hundreds of millions of dollars, and any repairs during orbital spaceflight are extremely difficult or not possible at all—there is no room for failure. Therefore, it is critically important to address the effects of TID and SEE in order to address the reliability concerns of the whole system. One of the most basic ways to address the potentially damaging effects of radiation is to use backup or redundant multiplexers that only come online if the primary multiplexer loses its functionality. The term for this form of redundant systems is cold sparing.

Another solution is to up-screen commercially available multiplexers for radiation hardened environments. This option has potential advantages from a time-to-market standpoint as the ICs are readily available and very cost effective. However, there are some drawbacks with this approach. Often times, it can be a gamble as to whether a part will successfully pass all of the qualification and radiation tests. And sometimes the availability of these parts can be a hurdle as commercial IC life cycles are much shorter than satellite lifetimes.

The next solution, which is often the most cost-effective, is to purchase analog multiplexers rated for operation in radiation environments. A couple examples include the ISL71840SEH 30V 16-channel multiplexer and the ISL71841SEH 30V 32-channel multiplexer. These ICs deliver SEL robustness in heavy ion environments. Both multiplexers provide a cold spare redundant capability, allowing the connection of 2-3 additional unpowered multiplexers to a common data input line. This is an especially important feature for mission-critical space flights lasting up to 20 years. If required, a redundant multiplexer is immediately activated.



Figure 3. Rad hard ISL71840SEH 16-channel multiplexer and ISL71841SEH 32-channel multiplexer

Conclusion

With analog multiplexers being an integral part of satellites and other high reliability applications with sensors and signal processing, it's important to consider the effects of TID and SEE because a nonfunctional or even parametrically degraded multiplexer can potentially cripple the operation of the entire satellite. To ensure no mission fails, having a cold spare redundant capability is mandatory for mission-critical, long duration space flights. If for any reason a multiplexer fails, a redundant multiplexer can be immediately activated.

Next Steps

- [Learn more about the ISL71840/41SEH](#)
- [Get the datasheet](#)
- [Download the test reports](#)
- [Watch a demo video](#)

###

About Renesas Electronics Corporation

Renesas Electronics Corporation delivers trusted embedded design innovation with complete semiconductor solutions that enable billions of connected, intelligent devices to enhance the way people work and live—securely and safely. A global leader in microcontrollers, analog, power, and SoC products, Renesas provides the expertise, quality, and comprehensive solutions for a broad range of Automotive, Industrial, Home Electronics, Office Automation and Information Communication Technology applications to help shape a limitless future. Learn more at [renesas.com](https://www.renesas.com)

+1 408-432-8888 | © Renesas Electronics America. All rights reserved. Renesas (and design) are trademarks owned by Renesas Electronics Corporation or one of its subsidiaries. All other trademarks mentioned are the property of their respective owners.