

To our customers,

Old Company Name in Catalogs and Other Documents

On April 1st, 2010, NEC Electronics Corporation merged with Renesas Technology Corporation, and Renesas Electronics Corporation took over all the business of both companies. Therefore, although the old company name remains in this document, it is a valid Renesas Electronics document. We appreciate your understanding.

Renesas Electronics website: <http://www.renesas.com>

April 1st, 2010
Renesas Electronics Corporation

Issued by: Renesas Electronics Corporation (<http://www.renesas.com>)

Send any inquiries to <http://www.renesas.com/inquiry>.

RENESAS TECHNICAL UPDATE

Nippon Bldg., 2-6-2, Ohte-machi, Chiyoda-ku, Tokyo 100-0004, Japan
Renesas Technology Corp.

Product Category	MPU/MCU		Document No.	TN-H8*-A417A/E	Rev.	1.00
Title	The addition of TNP-64B package to H8/38004 and H8/38002S Group		Information Category	Technical Notification		
Applicable Product	H8/38004 H8/38002S	Lot No.	Reference Document	H8/3802,H8/38004,H8/38002S,H8/38104 Group Hardware Manual (REJ09B0024-0600)		
		All				

We would like to inform you of addition of TNP-64B package to H8/38004 and H8/38002S Group.

Preface:

Hardware Manual (Referring to Preface, page v of I)

• Before Changes

Item	H8/3802 Group		H8/38004 Group		H8/38002S Group	H8/38104 Group	
	ZTAT	Mask ROM	Flash ROM	Mask ROM	Mask ROM	Flash ROM	Mask ROM
Package	FP-64A	FP-64A	FP-64A	FP-64A	FP-64A	FP-64A	FP-64A
	FP-64E	FP-64E	FP-64E	FP-64E	FP-64K	FP-64E	FP-64E
	DP-64S	DP-64S					
		die	die				
Operating temperature	Standard specifications: -20 to 75°C, WTR: -40 to 85°C						

• After Changes

Item	H8/3802 Group		H8/38004 Group		H8/38002S Group	H8/38104 Group	
	ZTAT	Mask ROM	Flash ROM	Mask ROM	Mask ROM	Flash ROM	Mask ROM
Package	FP-64A	FP-64A	FP-64A	FP-64A	FP-64A	FP-64A	FP-64A
	FP-64E	FP-64E	FP-64E	FP-64E	FP-64K	FP-64E	FP-64E
			TNP-64B	TNP-64B	TNP-64B		
	DP-64S	DP-64S					
	die	die					
Operating temperature	Standard specifications: -20 to 75°C, WTR: -40 to 85°C						

Compact package:

Hardware Manual (Referring to Section 1.1, Features, page 3)

• Before Changes

Package	Code	Body Size	Pin Pitch
QFP-64	FP-64A	14.0 x 14.0 mm	0.8mm
LQFP-64	FP-64E	10.0 x 10.0 mm	0.5mm
LQFP-64	FP-64K	10.0 x 10.0 mm	0.5mm
DP-64S	DP-64S	17.0 x 57.6 mm	1.0mm
Die	-	-	-

• After Changes

Package	Code	Body Size	Pin Pitch
QFP-64	FP-64A	14.0 x 14.0 mm	0.8mm
LQFP-64	FP-64E	10.0 x 10.0 mm	0.5mm
LQFP-64	FP-64K	10.0 x 10.0 mm	0.5mm
P-VQFN-64	TNP-64B	8.0 x 8.0 mm	0.4mm
DP-64S	DP-64S	17.0 x 57.6 mm	1.0mm
Die	-	-	-

Pin Arrangement:

Hardware Manual (Referring to Section 1.3, Pin Arrangement, page 7)

- Before Changes

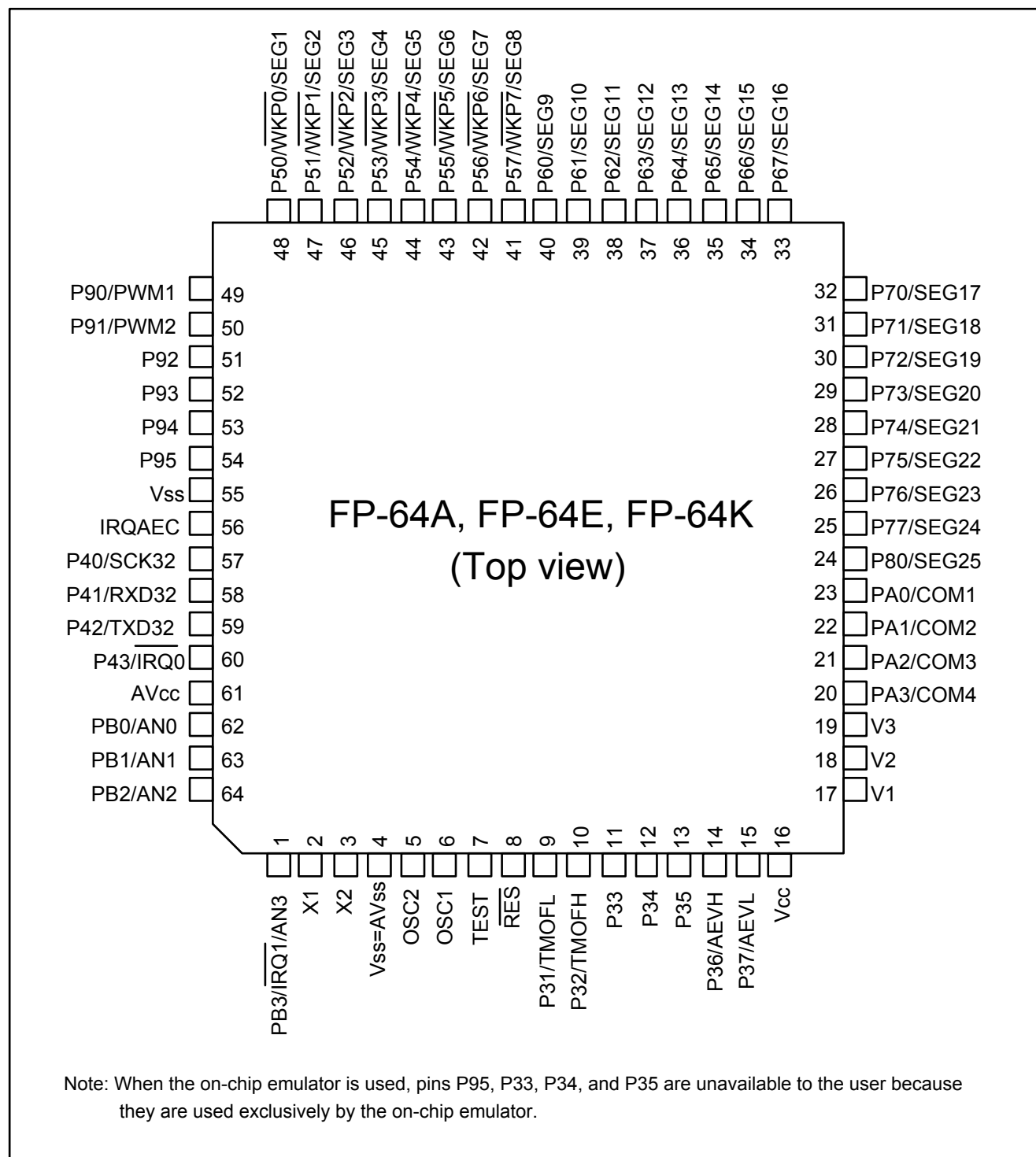

- After Changes

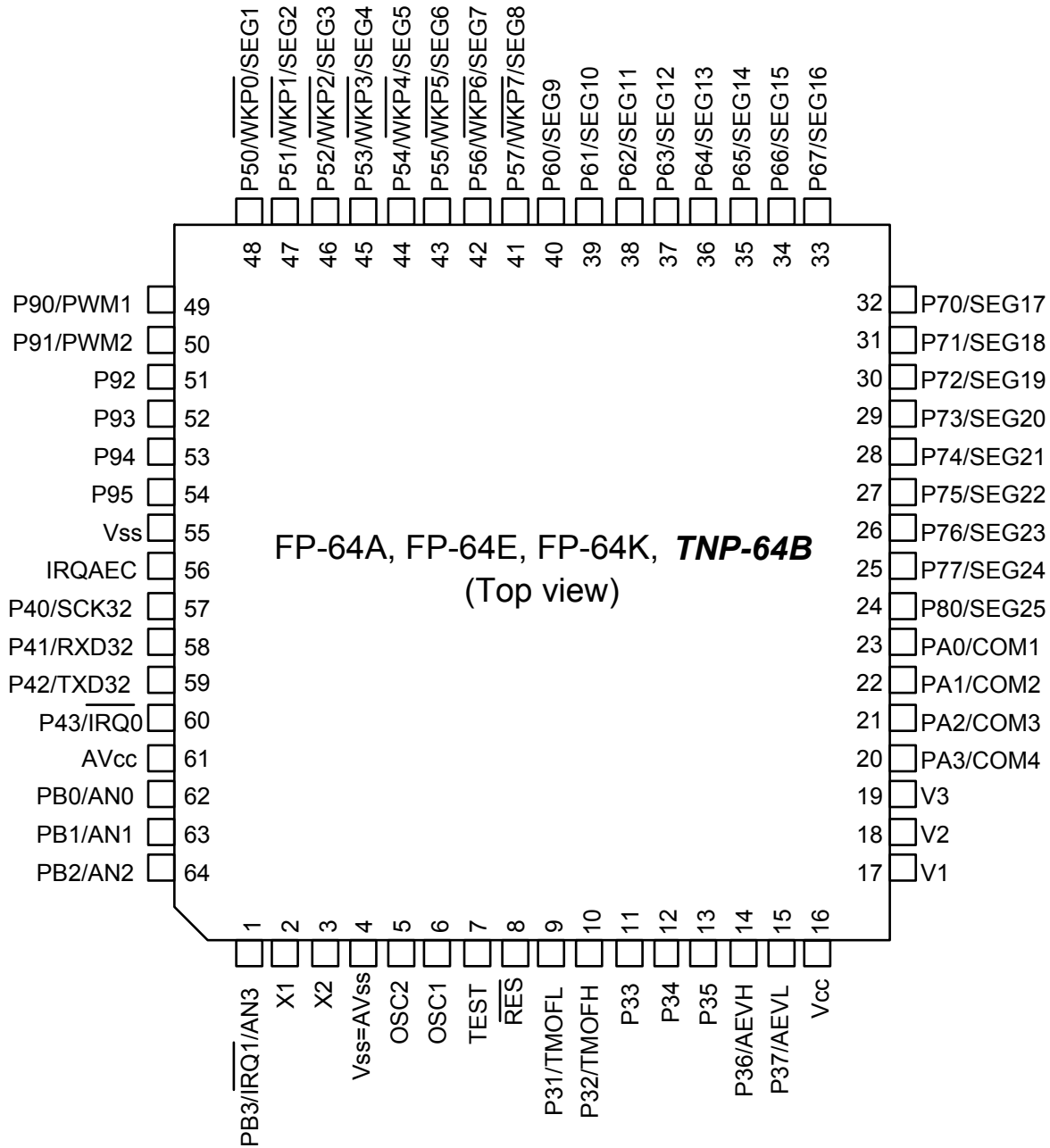

Note: When the on-chip emulator is used, pins P95, P33, P34, and P35 are unavailable to the user because they are used exclusively by the on-chip emulator.

Pin Functions:

Hardware Manual (Referring to Section 1.4, Pin Functions, page 19)

- Before Changes

Table 1.4 Pin Functions

Type	Symbol	Pin No.		Pad No. ^{*1*3}	Pad No. ^{*2}	I/O	Functions
		FP-64A, FP-64E, FP-64K	DP-64S				

- After Changes

Table 1.4 Pin Functions

Type	Symbol	Pin No.		Pad No. ^{*1*3}	Pad No. ^{*2}	I/O	Functions
		FP-64A, FP-64E, FP-64K, TNP-64B	DP-64S				

Socket Adapter Pin:

Hardware Manual (Referring to Section 6.10.1, Socket Adapter, Figure 6.12(1), page 162)

- Before Changes

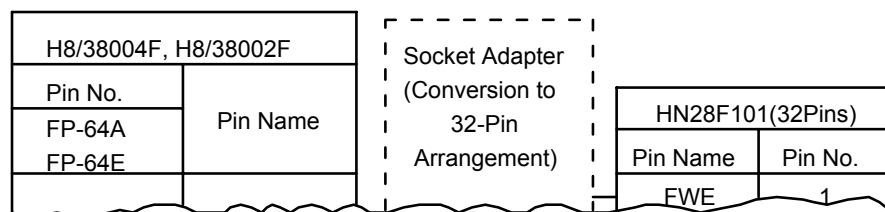

- After Changes

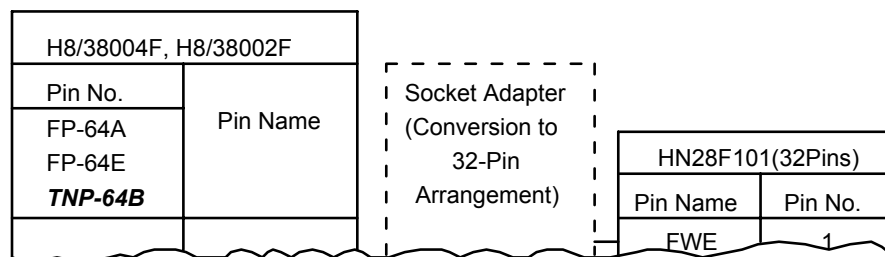

Product Code Lineup:

Hardware Manual (Referring to Appendix D, Product Code Lineup of H8/38004 Group, Table D.2, page 485)

• Before Changes

Product Type			Product Code	Model Marking	Package (Package Code)
H8/38004	Flash memory version	Regular product (2.7V)	HD64F38004H10	64F38004H10	64-pin QFP (FP-64A)
			HD64F38004FP10	F38004FP10	64-pin LQFP (FP-64E)
			HCD64F38004	-	Die
		Regular product (2.2V)	HD64F38004H4	64F38004H4	64-pin QFP (FP-64A)
			HD64F38004FP4	F38004FP4	64-pin LQFP (FP-64E)
			HCD64F38004C4	-	Die
	Product with wide-range temperature specifications (2.7V)	HD64F38004H10W	64F38004H10	64-pin QFP (FP-64A)	
		HD64F38004FP10W	F38004FP10	64-pin LQFP (FP-64E)	
	Mask ROM version	Regular product	HD64338004H	HD64338004H	64-pin QFP (FP-64A)
			HD64338004FP	38004(***)FP	64-pin LQFP (FP-64E)
			HCD64338004	-	Die
		Product with wide-range temperature specifications	HD64338004HW	HD64338004H	64-pin QFP (FP-64A)
HD64338004FPW			38004(***)FP	64-pin LQFP (FP-64E)	
H8/38003	Mask ROM version	Regular product	HD64338003H	HD64338003H	64-pin QFP (FP-64A)
			HD64338003FP	38003(***)FP	64-pin LQFP (FP-64E)
			HCD64338003	-	Die
		Product with wide-range temperature specifications	HD64338003HW	HD64338003H	64-pin QFP (FP-64A)
			HD64338003FPW	38003(***)FP	64-pin LQFP (FP-64E)
H8/38002	Flash memory version	Regular product (2.7V)	HD64F38002H10	64F38002H10	64-pin QFP (FP-64A)
			HD64F38002FP10	F38002FP10	64-pin LQFP (FP-64E)
			HCD64F38002	-	Die
		Regular product (2.2V)	HD64F38002H4	64F38002H4	64-pin QFP (FP-64A)
			HD64F38002FP4	F38002FP4	64-pin LQFP (FP-64E)
			HCD64F38002C4	-	Die
	Product with wide-range temperature specifications (2.7V)	HD64F38002H10W	64F38002H10	64-pin QFP (FP-64A)	
		HD64F38002FP10W	F38002FP10	64-pin LQFP (FP-64E)	
	Mask ROM version	Regular product	HD64338002H	HD64338002H	64-pin QFP (FP-64A)
			HD64338002FP	38002(***)FP	64-pin LQFP (FP-64E)
			HCD64338002	-	Die
		Product with wide-range temperature specifications	HD64338002HW	HD64338002H	64-pin QFP (FP-64A)
HD64338002FPW			38002(***)FP	64-pin LQFP (FP-64E)	
H8/38001	Mask ROM version	Regular product	HD64338001H	HD64338001H	64-pin QFP (FP-64A)
			HD64338001FP	38001(***)FP	64-pin LQFP (FP-64E)
			HCD64338001	-	Die
		Product with wide-range temperature specifications	HD64338001HW	HD64338001H	64-pin QFP (FP-64A)
			HD64338001FPW	38001(***)FP	64-pin LQFP (FP-64E)
H8/38000	Mask ROM version	Regular product	HD64338000H	HD64338000H	64-pin QFP (FP-64A)
			HD64338000FP	38000(***)FP	64-pin LQFP (FP-64E)
			HCD64338000	-	Die
		Product with wide-range temperature specifications	HD64338000HW	HD64338000H	64-pin QFP (FP-64A)
			HD64338000FPW	38000(***)FP	64-pin LQFP (FP-64E)

Legend:
(**): ROM code

• After Changes

Product Type			Product Code	Model Marking	Package (Package Code)	
H8/38004	Flash memory version	Regular product (2.7V)	HD64F38004H10	64F38004H10	64-pin QFP (FP-64A)	
			HD64F38004FP10	F38004FP10	64-pin LQFP (FP-64E)	
			HD64F38004FT10	F38004FT10	64-pin QFP (TNP-64B)	
			HCD64F38004	-	Die	
		Regular product (2.2V)	HD64F38004H4	64F38004H4	64-pin QFP (FP-64A)	
			HD64F38004FP4	F38004FP4	64-pin LQFP (FP-64E)	
			HD64F38004FT4	F38004FT4	64-pin QFP (TNP-64B)	
			HCD64F38004C4	-	Die	
		Product with wide-range temperature specifications (2.7V)	HD64F38004H10W	64F38004H10	64-pin QFP (FP-64A)	
	HD64F38004FP10W		F38004FP10	64-pin LQFP (FP-64E)		
	HD64F38004FT10W		F38004FT10	64-pin QFP (TNP-64B)		
	Mask ROM version	Regular product	HD64338004H	HD64338004H	64-pin QFP (FP-64A)	
			HD64338004FP	38004(***)FP	64-pin LQFP (FP-64E)	
			HD64338004FT	38004(***)FT	64-pin QFP (TNP-64B)	
			HCD64338004	-	Die	
Product with wide-range temperature specifications		HD64338004HW	HD64338004H	64-pin QFP (FP-64A)		
		HD64338004FPW	38004(***)FP	64-pin LQFP (FP-64E)		
		HD64338004FTW	38004(***)FT	64-pin QFP (TNP-64B)		
H8/38003		Mask ROM version	Regular product	HD64338003H	HD64338003H	64-pin QFP (FP-64A)
				HD64338003FP	38003(***)FP	64-pin LQFP (FP-64E)
	HD64338003FT			38003(***)FT	64-pin QFP (TNP-64B)	
			HCD64338003	-	Die	
	Product with wide-range temperature specifications		HD64338003HW	HD64338003H	64-pin QFP (FP-64A)	
			HD64338003FPW	38003(***)FP	64-pin LQFP (FP-64E)	
		HD64338003FTW	38003(***)FT	64-pin QFP (TNP-64B)		
	H8/38002	Flash memory version	Regular product (2.7V)	HD64F38002H10	64F38002H10	64-pin QFP (FP-64A)
				HD64F38002FP10	F38002FP10	64-pin LQFP (FP-64E)
HD64F38002FT10				F38002FT10	64-pin QFP (TNP-64B)	
			HCD64F38002	-	Die	
Regular product (2.2V)			HD64F38002H4	64F38002H4	64-pin QFP (FP-64A)	
			HD64F38002FP4	F38002FP4	64-pin LQFP (FP-64E)	
			HD64F38002FT4	F38002FT4	64-pin QFP (TNP-64B)	
			HCD64F38002C4	-	Die	
Product with wide-range temperature specifications (2.7V)			HD64F38002H10W	64F38002H10	64-pin QFP (FP-64A)	
		HD64F38002FP10W	F38002FP10	64-pin LQFP (FP-64E)		
		HD64F38002FT10W	F38002FT10	64-pin QFP (TNP-64B)		
Mask ROM version		Regular product	HD64338002H	HD64338002H	64-pin QFP (FP-64A)	
			HD64338002FP	38002(***)FP	64-pin LQFP (FP-64E)	
			HD64338002FT	38002(***)FT	64-pin QFP (TNP-64B)	
			HCD64338002	-	Die	
	Product with wide-range temperature specifications	HD64338002HW	HD64338002H	64-pin QFP (FP-64A)		
		HD64338002FPW	38002(***)FP	64-pin LQFP (FP-64E)		
HD64338002FTW		38002(***)FT	64-pin QFP (TNP-64B)			
H8/38001	Mask ROM version	Regular product	HD64338001H	HD64338001H	64-pin QFP (FP-64A)	
			HD64338001FP	38001(***)FP	64-pin LQFP (FP-64E)	
			HCD64338001	-	Die	
		Product with wide-range temperature specifications	HD64338001HW	HD64338001H	64-pin QFP (FP-64A)	
			HD64338001FPW	38001(***)FP	64-pin LQFP (FP-64E)	
H8/38000	Mask ROM version	Regular product	HD64338000H	HD64338000H	64-pin QFP (FP-64A)	
			HD64338000FP	38000(***)FP	64-pin LQFP (FP-64E)	
			HCD64338000	-	Die	
		Product with wide-range temperature specifications	HD64338000HW	HD64338000H	64-pin QFP (FP-64A)	
			HD64338000FPW	38000(***)FP	64-pin LQFP (FP-64E)	

Legend:
(***) : ROM code

Hardware Manual (Referring to Appendix D, Product Code Lineup of H8/38002S Group, Table D.3, page 487)

• Before Changes

Product Type			Product Code	Model Marking	Package (Package Code)
H8/38002S	Mask ROM version	Regular product	HD64338002SH	38002(***)H	64-pin QFP (FP-64A)
			HD64338002SFZ	38002(***)	64-pin LQFP (FP-64K)
	Product with wide-range temperature specifications		HD64338002SHW	38002(***)H	64-pin QFP (FP-64A)
			HD64338002SFZW	38002(***)	64-pin LQFP (FP-64K)
H8/38001S	Mask ROM version	Regular product	HD64338001SH	38001(***)H	64-pin QFP (FP-64A)
			HD64338001SFZ	38001(***)	64-pin LQFP (FP-64K)
	Product with wide-range temperature specifications		HD64338001SHW	38001(***)H	64-pin QFP (FP-64A)
			HD64338001SFZW	38001(***)	64-pin LQFP (FP-64K)
H8/38000S	Mask ROM version	Regular product	HD64338000SH	38000(***)H	64-pin QFP (FP-64A)
			HD64338000SFZ	38000(***)	64-pin LQFP (FP-64K)
	Product with wide-range temperature specifications		HD64338000SHW	38000(***)H	64-pin QFP (FP-64A)
			HD64338000SFZW	38000(***)	64-pin LQFP (FP-64K)

Legend:

(**): ROM code

• After Changes

Product Type			Product Code	Model Marking	Package (Package Code)
H8/38002S	Mask ROM version	Regular product	HD64338002SH	38002(***)H	64-pin QFP (FP-64A)
			HD64338002SFZ	38002(***)	64-pin LQFP (FP-64K)
	Product with wide-range temperature specifications		HD64338002SFT	38002(***)FT	64-pin QFP (TNP-64B)
			HD64338002SHW	38002(***)H	64-pin QFP (FP-64A)
			HD64338002SFZW	38002(***)	64-pin LQFP (FP-64K)
			HD64338002SFTW	38002(***)FT	64-pin QFP (TNP-64B)
H8/38001S	Mask ROM version	Regular product	HD64338001SH	38001(***)H	64-pin QFP (FP-64A)
			HD64338001SFZ	38001(***)	64-pin LQFP (FP-64K)
	Product with wide-range temperature specifications		HD64338001SFT	38001(***)FT	64-pin QFP (TNP-64B)
			HD64338001SHW	38001(***)H	64-pin QFP (FP-64A)
			HD64338001SFZW	38001(***)	64-pin LQFP (FP-64K)
			HD64338001SFTW	38001(***)FT	64-pin QFP (TNP-64B)
H8/38000S	Mask ROM version	Regular product	HD64338000SH	38000(***)H	64-pin QFP (FP-64A)
			HD64338000SFZ	38000(***)	64-pin LQFP (FP-64K)
	Product with wide-range temperature specifications		HD64338000SFT	38000(***)FT	64-pin QFP (TNP-64B)
			HD64338000SHW	38000(***)H	64-pin QFP (FP-64A)
			HD64338000SFZW	38000(***)	64-pin LQFP (FP-64K)
			HD64338000SFTW	38000(***)FT	64-pin QFP (TNP-64B)

Legend:

(**): ROM code

Package Dimensions:

Hardware Manual (Referring to Appendix E, Package Dimensions, page 490)

JEITA Package Code	RENESAS Code	Previous Code	MASS[Typ.]
P-VQFN64-8x8-0.40	PVQN0064LB-A	TNP-64B/TNP-64BV	0.12g

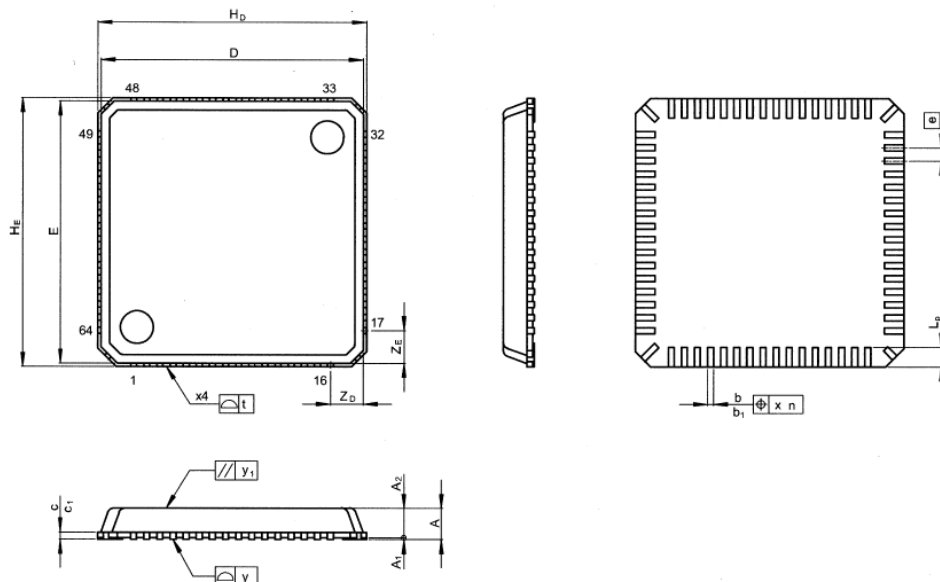

Reference Symbol	Dimension in Millimeters		
	Min	Nom	Max
D	—	8.0	—
E	—	8.0	—
A ₂	—	0.89	—
A	—	—	0.95
A ₁	0.005	0.02	0.04
b	0.13	0.18	0.23
b ₁	—	0.16	—
⌀	—	0.4	—
L _p	0.50	0.60	0.70
x	—	—	0.05
y	—	—	0.05
y ₁	—	—	0.2
t	—	—	0.2
H _D	—	8.2	—
H _E	—	8.2	—
Z _D	—	1.0	—
Z _E	—	1.0	—
c	0.17	0.22	0.25
c ₁	—	0.20	—