

Brief Description

The ZLED7002 toggle (side-step) dual-channel LED driver is one of our ZLED family of LED control ICs. It operates in the lower DC voltage supply range of 2.7V to 5.5V. This unique LED driver is capable of controlling a MAIN channel and a SUB channel. Typically, only one of the two channels is active and the ZLED7002 toggles between the channels automatically in response to the voltage supply level and the related voltage at the UV (under-voltage protection) pin. A high-to-low transition of the power supply causes the output current to switch from the MAIN channel to the SUB channel if the UV pin voltage (V_{UV-PIN}) is below the ZLED7002's under-voltage threshold (V_{UVTHRS} =1.17V, typical). A low-to-high transition switches the output current from the SUB channel to the MAIN channel if the UV pin voltage is 80mV (typical) above the under-voltage threshold.

The MAIN channel is a configurable constant current source driving the MAIN LED string with a maximum current draw of 250mA. The MAIN LED channel current is set by an external resistor (R3) connected to the Iset pin. Alternately, the SUB channel is activated when the ZLED7002's SUB pin is pulled to ground. Its current is determined by the forward voltage of the SUB LED and external components. The SUB channel can drive up to 100mA current through the LED channel when active.

The ZLED7002 enables voltage-level indicator applications and low-power battery-driven lighting applications that require switching to a lower-current LED channel when the supply is low, which extends the lighting life-time. Because the dropout voltage (V_{DP}) is minimal (as low as 0.1V when the MAIN channel output current is ~200mA), the ZLED7002 is optimal for battery-powered applications. Capable of operating efficiently with DC voltage supplies ranging from 2.7V to 5.5V, it is ideal for small portable lighting applications.

The ZLED7002 can also reduce bill-of-material costs because very few external components are required for most applications, making it an optimal fit for small devices for which lighting lifetime is critical. Only four resistors, a diode, and a capacitor are needed for a typical basic application.

Features

- Automatic MAIN channel short-circuit protection switches the output current to the SUB channel if the MAIN LED is shorted
- Under-voltage power supply detection
- Over-temperature protection

Benefits

- Extends lighting life-time by switching to a lower-current LED channel when the supply is low
- 80mV (typical) hysteresis prevents unintended switching activation due to power supply ripple
- Ultra low quiescent current: 250µA typical
- Very few external components needed for operation

Available Support

- Evaluation Kit

Physical Characteristics

- Voltage supply: 2.7V to 5.5V DC
- Operating temperature: -25°C to 85°C
- Small SOP8 package

ZLED7002 Typical Application Circuit

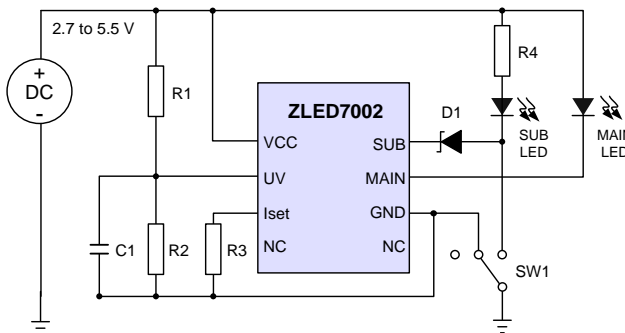

SOP8 Package Dimensions and Pin Assignments

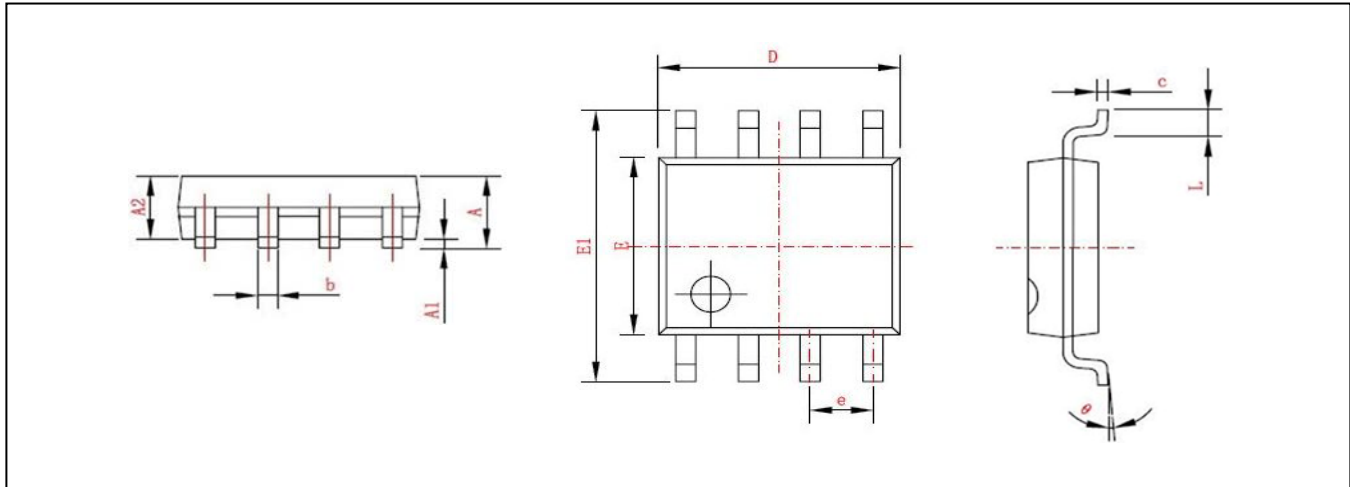

Symbol	Dimension (mm, except θ)	
	Min	Max
A	1.350	1.750
A1	0.100	0.250
A2	1.450 Typical	
b	0.350	0.490
c	0.178	0.250
D	4.800	5.000
E	3.800	4.000
E1	5.800	6.240
e	1.270 Typical	
L	0.400	1.270
θ	0°	8°

Typical Applications

- ❖ Battery-driven LED lighting including
 - Helmet lighting
 - Bicycle lighting
 - Miner lamps
 - Pocket lights
- ❖ Voltage-level indicators
- ❖ General purpose low-voltage industrial and consumer LED applications

Ordering Information

Product Sales Code	Description	Package
ZLED7002ZI1R	ZLED7002 – Toggle (Side-Step) Dual-Channel LED Driver	SOP8 (Tape & Reel)
ZLED7002KIT-E1	ZLED7002 Evaluation Kit	Kit

IMPORTANT NOTICE AND DISCLAIMER

RENESAS ELECTRONICS CORPORATION AND ITS SUBSIDIARIES (“RENESAS”) PROVIDES TECHNICAL SPECIFICATIONS AND RELIABILITY DATA (INCLUDING DATASHEETS), DESIGN RESOURCES (INCLUDING REFERENCE DESIGNS), APPLICATION OR OTHER DESIGN ADVICE, WEB TOOLS, SAFETY INFORMATION, AND OTHER RESOURCES “AS IS” AND WITH ALL FAULTS, AND DISCLAIMS ALL WARRANTIES, EXPRESS OR IMPLIED, INCLUDING, WITHOUT LIMITATION, ANY IMPLIED WARRANTIES OF MERCHANTABILITY, FITNESS FOR A PARTICULAR PURPOSE, OR NON-INFRINGEMENT OF THIRD-PARTY INTELLECTUAL PROPERTY RIGHTS.

These resources are intended for developers who are designing with Renesas products. You are solely responsible for (1) selecting the appropriate products for your application, (2) designing, validating, and testing your application, and (3) ensuring your application meets applicable standards, and any other safety, security, or other requirements. These resources are subject to change without notice. Renesas grants you permission to use these resources only to develop an application that uses Renesas products. Other reproduction or use of these resources is strictly prohibited. No license is granted to any other Renesas intellectual property or to any third-party intellectual property. Renesas disclaims responsibility for, and you will fully indemnify Renesas and its representatives against, any claims, damages, costs, losses, or liabilities arising from your use of these resources. Renesas' products are provided only subject to Renesas' Terms and Conditions of Sale or other applicable terms agreed to in writing. No use of any Renesas resources expands or otherwise alters any applicable warranties or warranty disclaimers for these products.

(Disclaimer Rev.1.01 Jan 2024)

Corporate Headquarters

TOYOSU FORESIA, 3-2-24 Toyosu,
Koto-ku, Tokyo 135-0061, Japan
www.renesas.com

Trademarks

Renesas and the Renesas logo are trademarks of Renesas Electronics Corporation. All trademarks and registered trademarks are the property of their respective owners.

Contact Information

For further information on a product, technology, the most up-to-date version of a document, or your nearest sales office, please visit www.renesas.com/contact-us/.