

ISL95813

Single-Phase Core Controller for VR12.6

FN8449
Rev 2.00
January 29, 2015

The ISL95813 single-phase controller provides a fully compliant VR12.6 power supply solution for Intel™ microprocessors. It provides a tightly regulated output voltage that is programmed through a high speed serial bus interface with the CPU. This interface also allows the CPU to acquire real-time information from the voltage regulator (VR), which includes load current and VR temperature.

Based on Intersil's Robust Ripple Regulator R3™ Technology, the PWM modulator provides faster transient response and settling time when compared against traditional modulation schemes. Its variable frequency topology also allows for natural period stretching Discontinuous Conduction Mode (DCM) for increased efficiency and power savings in light load situations.

The ISL95813 has several other key features that include: DCR current sensing with single NTC thermal compensation; discrete resistor current sensing; differential remote voltage feedback; and user-programmable boot voltage, I_{MAX}, T_{MAX}, voltage transition slew rate and switching frequency.

Related Literature

[AN1846](#) Designer's Guide to the ISL95813 Evaluation Board

Features

- Full VR12.6 specification compliance
- Wide input voltage range: 4.6V to 25V
- R3™ control architecture delivers excellent transient response and power state mode transitions
- Current monitor (IMON) with temperature compensation
- VRHOT# indicator for CPU protection
- Digitally selectable switching frequency:
 - 425kHz, 550kHz, 700kHz with ECO and PRO options
- Enhanced light-load efficiency discontinuous conduction mode operation
- Ultra small 20 Ld 3mmx4mm QFN package
- Enable and power-good monitor

Applications

- Notebook computers
- Tablets, ultrabooks and AIO

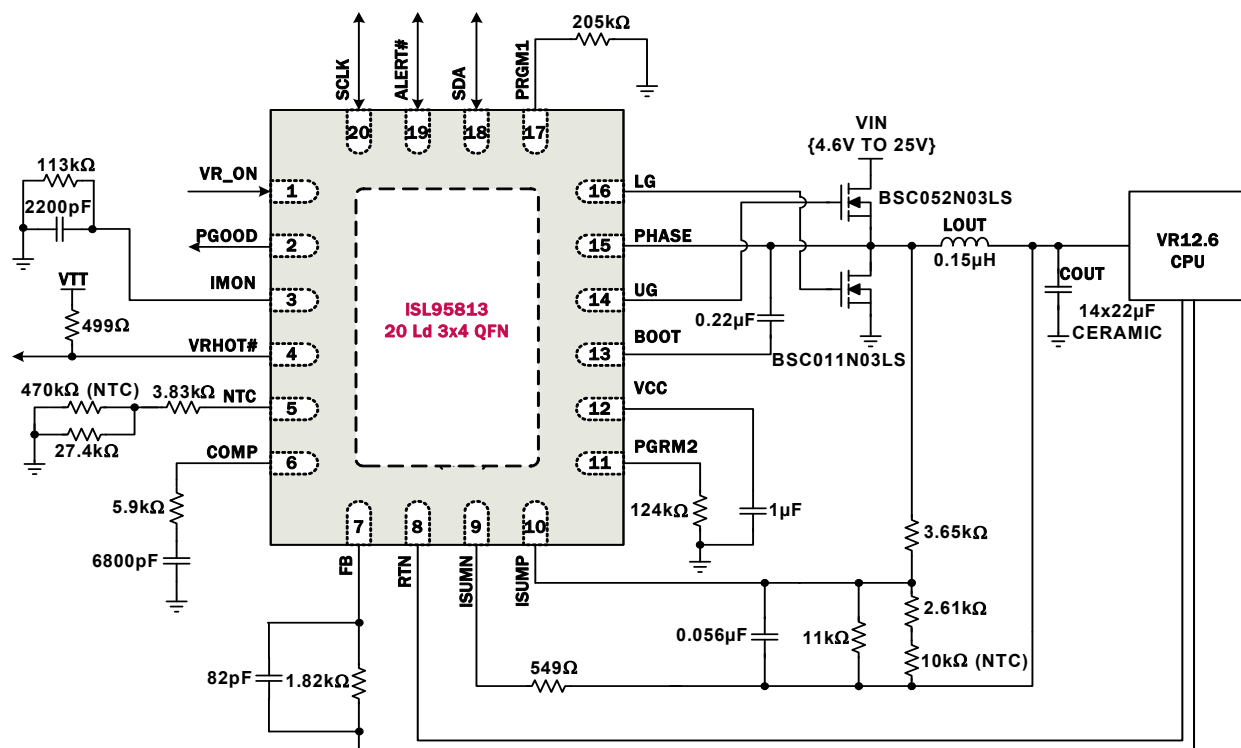

FIGURE 1. TYPICAL 40AMAX, 12.6, APPLICATION DIAGRAM

© Copyright Intersil Americas LLC 2013-2015. All Rights Reserved.
All trademarks and registered trademarks are the property of their respective owners.

For additional products, see www.intersil.com/en/products.html

Intersil products are manufactured, assembled and tested utilizing ISO9001 quality systems as noted in the quality certifications found at www.intersil.com/en/support/qualandreliability.html

Intersil products are sold by description only. Intersil may modify the circuit design and/or specifications of products at any time without notice, provided that such modification does not, in Intersil's sole judgment, affect the form, fit or function of the product. Accordingly, the reader is cautioned to verify that datasheets are current before placing orders. Information furnished by Intersil is believed to be accurate and reliable. However, no responsibility is assumed by Intersil or its subsidiaries for its use; nor for any infringements of patents or other rights of third parties which may result from its use. No license is granted by implication or otherwise under any patent or patent rights of Intersil or its subsidiaries.

For information regarding Intersil Corporation and its products, see www.intersil.com