

**Description**

The F6503 is an 8-channel transmitter (TX) silicon IC designed using a SiGe BiCMOS process for CDL phased array applications. The core IC has 360° 6-bit phase control coupled with 35dB 6-bit gain control on each channel to achieve fine beam steering and gain compensation between radiating channels. The device has a 25dB nominal gain and 13dBm OP1dB. The core chip achieves an RMS phase error of 3° and an RMS gain error of 0.4dB over the frequency of operation. The typical total power consumption is 1.4W (175mW per channel) at OP1dB.

**Competitive Advantage**

- High integration
- Orthogonality of phase and amplitude control
- Advanced Serial Peripheral Interface (SPI) with 4 state memory
- Superior channel-to-channel isolation
- Minimal footprint

**Typical Applications**

- CDL Terminals
- Aerospace and Maritime
- Beam Steering
- Point-to-Point (Line-of-Sight) Communications

**Features**

- 14GHz to 16GHz operation
- 8 radiation channels
- 6-bit phase control
- 6-bit gain control
- 50ns typical gain settling time
- 20ns typical phase settling time
- 3° typical RMS phase error
- 0.4dB typical RMS gain error
- 35dB gain attenuation range
- 5-bit IC address
- Integrated proportional-to-absolute temperature (PTAT) sensor with external biasing
- -40°C to +95°C internal temperature sensor
- Programmable 4-state on-chip memory
- Supply voltage: +2.1V to +2.5V
- -40°C to +95°C ambient operating temperature range
- 27°C typical ambient operating temperature
- 3.8mm x 4.6mm, 62-BGA package

**Block Diagram**

**Figure 1. Block Diagram**

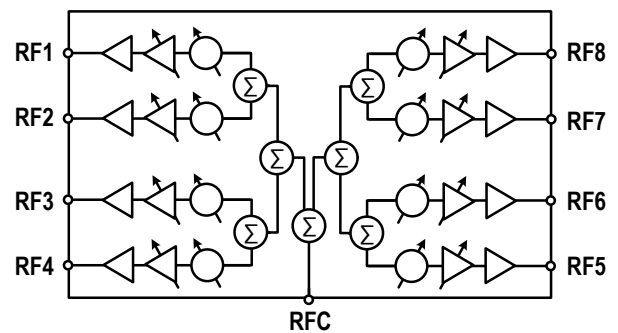

## Ordering Information

Orderable Part Number	Package	MSL Rating	Carrier Type	Temperature
F6503AVGK	3.8mm x 4.6mm 62-BGA	MSL 3	Tray	-40° to +95°C
F6503AVGK8	3.8mm x 4.6mm 62-BGA	MSL 3	Reel	-40° to +95°C
F6503EVB	Evaluation Board			
F6503EVS	F6503 Evaluation Kit System, including Evaluation Board, 2x THRU Reference Fixture, FT2232H Mini-Module Microcontroller, Digital Cable, Power Cable, and USB-to-Mini Cable			

Advanced

## IMPORTANT NOTICE AND DISCLAIMER

RENESAS ELECTRONICS CORPORATION AND ITS SUBSIDIARIES (“RENESAS”) PROVIDES TECHNICAL SPECIFICATIONS AND RELIABILITY DATA (INCLUDING DATASHEETS), DESIGN RESOURCES (INCLUDING REFERENCE DESIGNS), APPLICATION OR OTHER DESIGN ADVICE, WEB TOOLS, SAFETY INFORMATION, AND OTHER RESOURCES “AS IS” AND WITH ALL FAULTS, AND DISCLAIMS ALL WARRANTIES, EXPRESS OR IMPLIED, INCLUDING, WITHOUT LIMITATION, ANY IMPLIED WARRANTIES OF MERCHANTABILITY, FITNESS FOR A PARTICULAR PURPOSE, OR NON-INFRINGEMENT OF THIRD PARTY INTELLECTUAL PROPERTY RIGHTS.

These resources are intended for developers skilled in the art designing with Renesas products. You are solely responsible for (1) selecting the appropriate products for your application, (2) designing, validating, and testing your application, and (3) ensuring your application meets applicable standards, and any other safety, security, or other requirements. These resources are subject to change without notice. Renesas grants you permission to use these resources only for development of an application that uses Renesas products. Other reproduction or use of these resources is strictly prohibited. No license is granted to any other Renesas intellectual property or to any third party intellectual property. Renesas disclaims responsibility for, and you will fully indemnify Renesas and its representatives against, any claims, damages, costs, losses, or liabilities arising out of your use of these resources. Renesas' products are provided only subject to Renesas' Terms and Conditions of Sale or other applicable terms agreed to in writing. No use of any Renesas resources expands or otherwise alters any applicable warranties or warranty disclaimers for these products.

(Rev.1.0 Mar 2020)

### Corporate Headquarters

TOYOSU FORESIA, 3-2-24 Toyosu,  
Koto-ku, Tokyo 135-0061, Japan  
[www.renesas.com](http://www.renesas.com)

### Contact Information

For further information on a product, technology, the most up-to-date version of a document, or your nearest sales office, please visit:  
[www.renesas.com/contact/](http://www.renesas.com/contact/)

### Trademarks

Renesas and the Renesas logo are trademarks of Renesas Electronics Corporation. All trademarks and registered trademarks are the property of their respective owners.