

Tsi382A (BGA) Evaluation Board Schematics

TABLE OF CONTENTS

Sheet 1 -	Table of Contents
Sheet 2 -	Block Diagram
Sheet 3 -	Tsi382A PCIe/Miscellaneous
Sheet 4 -	PCIe Connectors
Sheet 5 -	Tsi382A PCI Interface
Sheet 6 -	PCI Slot 0 (R/A Top)
Sheet 7 -	PCI Slot 1 (Vertical)
Sheet 8 -	PCI Slot 3 (Vertical)
Sheet 9 -	PCI Slot 2 (Vertical)
Sheet 10 -	Clock Distribution
Sheet 11 -	Power Sources
Sheet 12 -	Tsi382A Power/Regulators
Sheet 13 -	PCI Regulators
Sheet 14 -	Test Devices
Sheet 15 -	Test Devices Cont'd



TITLE :			
TABLE OF CONTENTS			
SIZE	DRAWING NUMBER :	Version:	DESIGNER :
C	60E204A_SC001_01	1.0	PHILIP LAUZON
LAST MODIFIED DATE :			SHEET OF
9-24-2007_9:40			1 15

BLOCK DIAGRAM

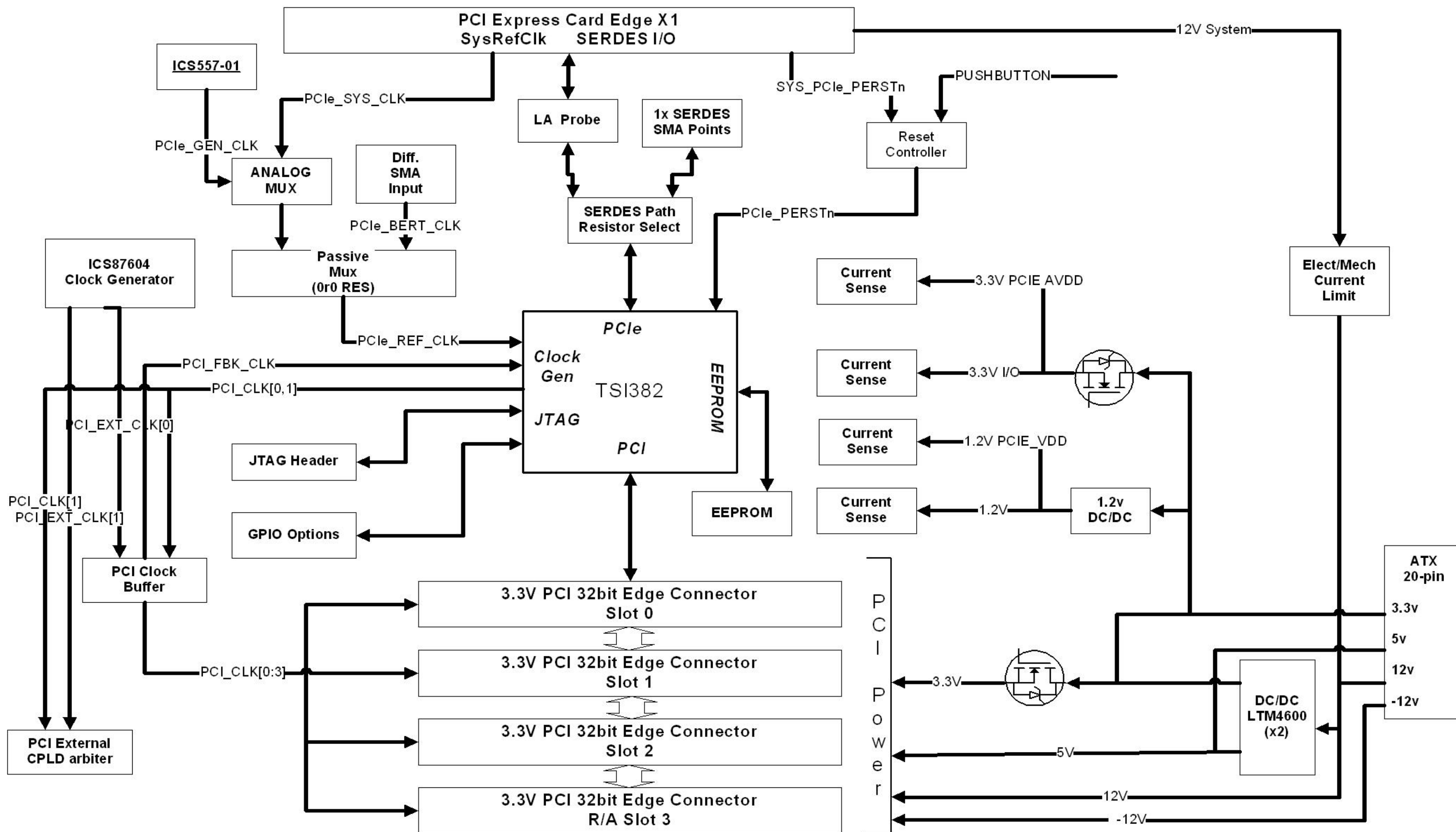

TUNDRA

TITLE : **BLOCK DIAGRAM**

SIZE	DRAWING NUMBER :	Version:	DESIGNER :
C	60E204A_SC001_01	1.0	PHILIP LAUZON
LAST MODIFIED DATE :			SHEET
1-9-2008_14:55			2 OF 15

TSI382A PCIE/MISCELLANEOUS

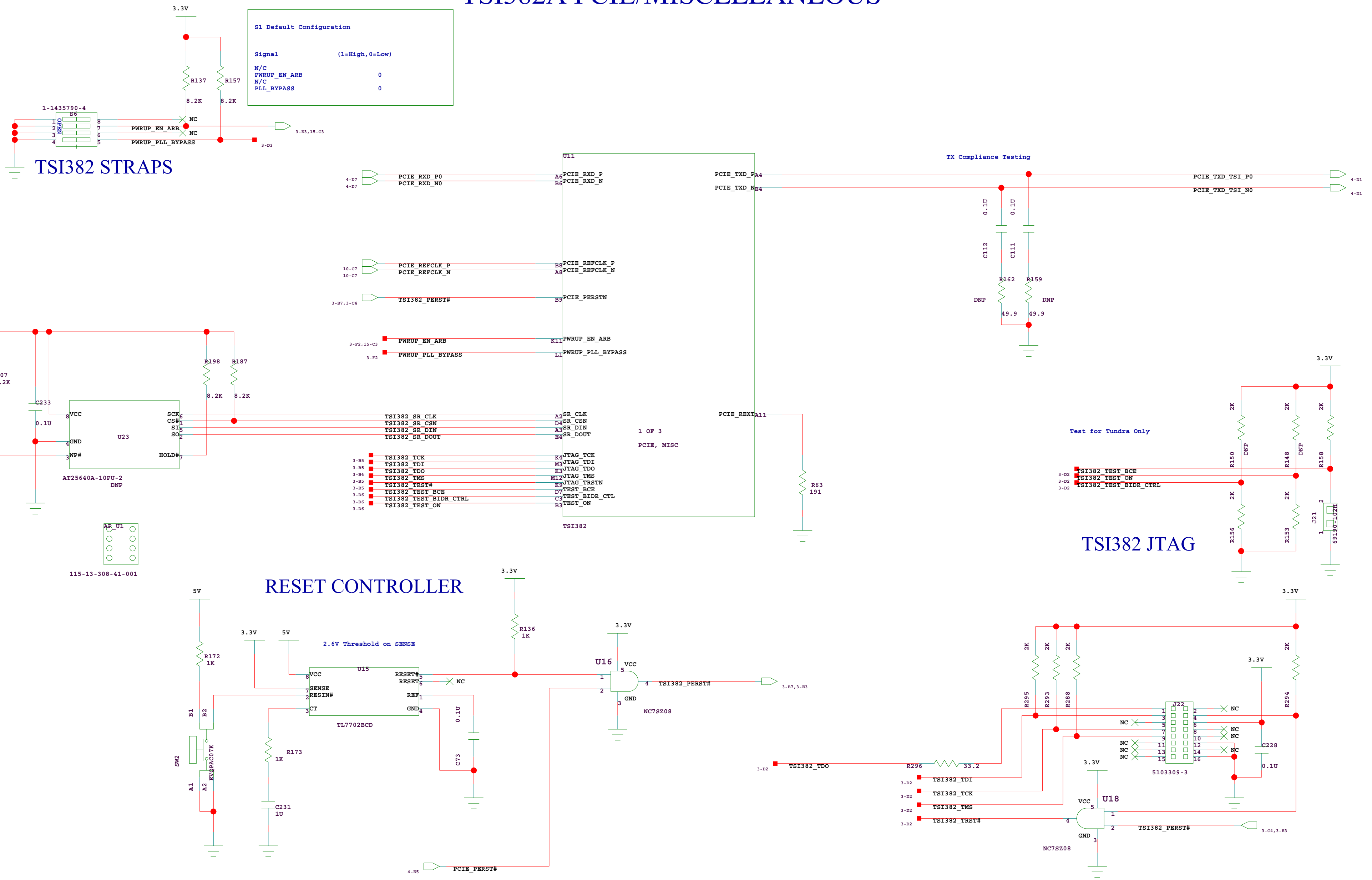

S1 Default Configuration

Signal	(1=High,0=Low)
N/C	0
PWRUP_EN_ARB	0
N/C	0
PLL_BYPASS	0

TUNDRA

TITLE :
TSI382A PCIE/MISC

SIZE C	DRAWING NUMBER : 60E204A0_SC001_01	Version: 1.0	DESIGNER : PHILIP LAUZON
------------------	---------------------------------------	-----------------	-----------------------------

LAST MODIFIED DATE :
9-24-2007_9:40

SHEET **3** OF **15**

PCIE CONNECTORS

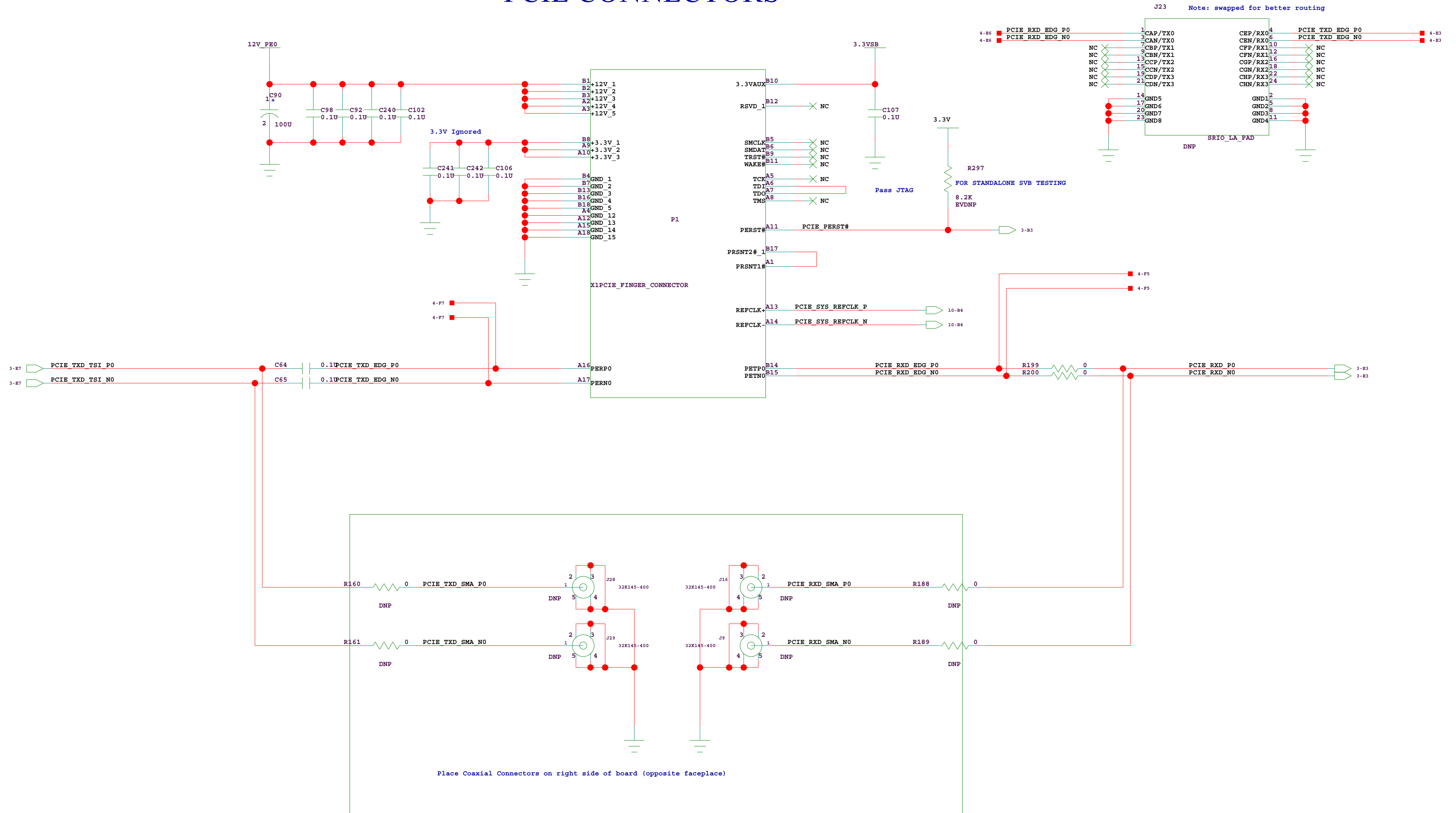

TITLE :			
PCIE CONNECTORS			
SIZE	DRAWING NUMBER :	Version:	DESIGNER :
C	60E204A_SCO01_01	1.0	PHILIP LAUZON
LAST MODIFIED DATE :			SHEET
1-9-2008_14:18			4 OF 15

TSI382A PCI INTERFACE

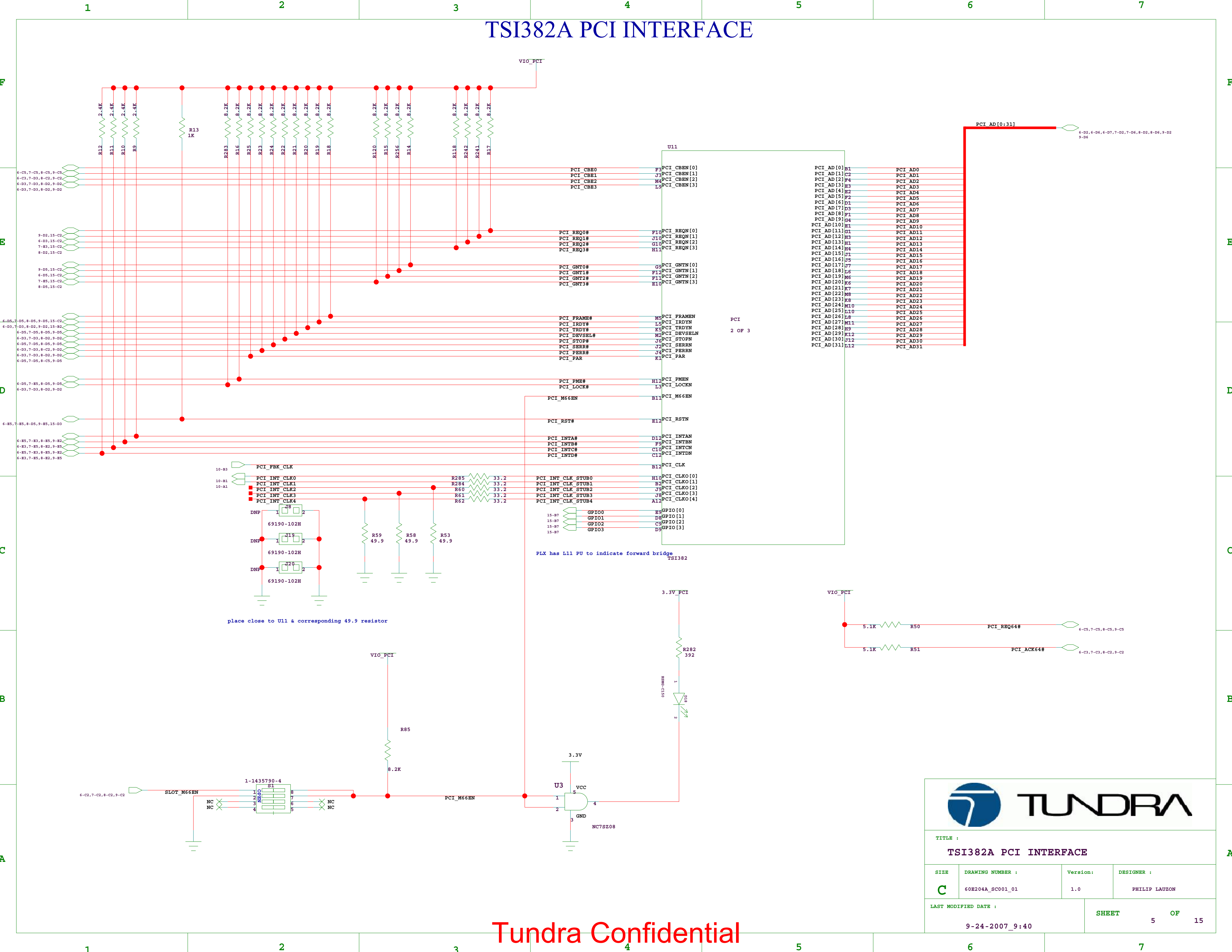

2 OF 3

PLX has L11 PU to indicate forward bridge TSI382

place close to U11 & corresponding 49.9 resistor

TUNDRA

TITLE :
TSI382A PCI INTERFACE

SIZE C	DRAWING NUMBER : 60E204A_SC001_01	Version: 1.0	DESIGNER : PHILIP LAUZON
-----------	--------------------------------------	-----------------	-----------------------------

LAST MODIFIED DATE :
9-24-2007_9:40

SHEET 5 OF 15

PCI SLOT 0 (R/A)

IDSEL AD16
 - Required Interrupt Routing
 SLOT : BRIDGE
 INTA -> INTA
 INTB -> INTB
 INTC -> INTC
 INTD -> INTD
 - PCI Clock PCI_CLK0
 - PCI Arbitration PCI_GNT#1/PCI_REQ#1

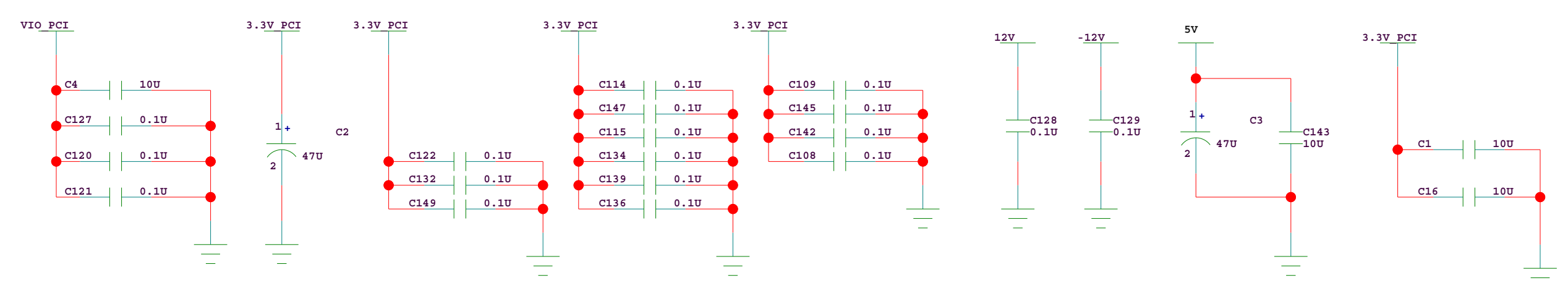
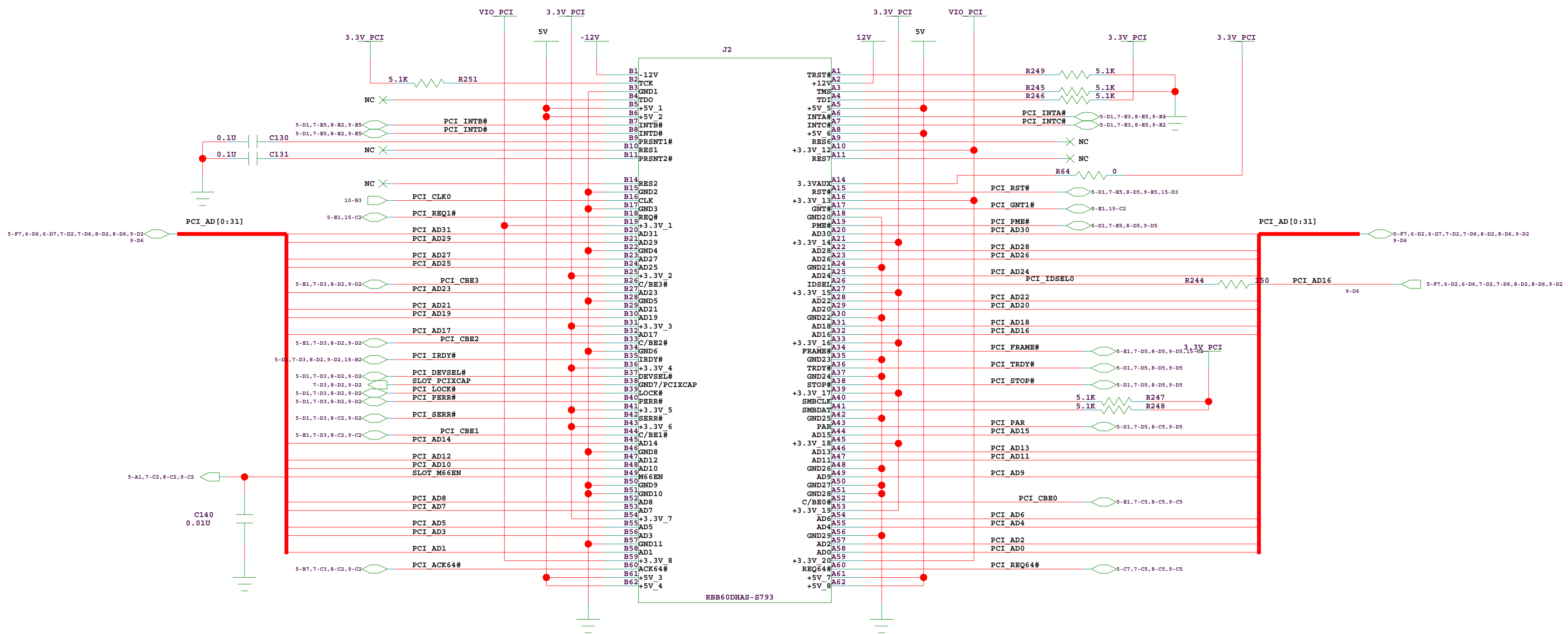



TITLE :
PCI SLOT 0

SIZE C	DRAWING NUMBER : 60E204A_SC001_01	Version: 1.0	DESIGNER : PHILIP LAUZON
LAST MODIFIED DATE : 9-24-2007_9:40		SHEET 6 OF 15	

PCI SLOT 1 (Vertical)

IDSEL AD17
 - Required Interrupt Routing
 SLOT : BRIDGE
 INTA -> INTB
 INTB -> INTC
 INTC -> INTD
 INTD -> INTA

 - PCI Clock PCI_CLK1

 - PCI Arbitration PCI_GNT#2/PCI_REQ#2



Tundra Confidential

TUNDRA
 TITLE :
PCI SLOT 1
 SIZE: C DRAWING NUMBER : 60E204A_SCO01_01 Version: 1.0 DESIGNER : PHILIP LAUZON
 LAST MODIFIED DATE : 9-24-2007_9:40 SHEET 7 OF 15

PCI SLOT 3 (Vertical)

IDSEL AD18
 - Required Interrupt Routing
 SLOT : BRIDGE
 INTA -> INTC
 INTB -> INTD
 INTC -> INTA
 INTD -> INTB

 - PCI Clock PCI_CLK2

 - PCI Arbitration PCI_GNT#3/PCI_REQ#3

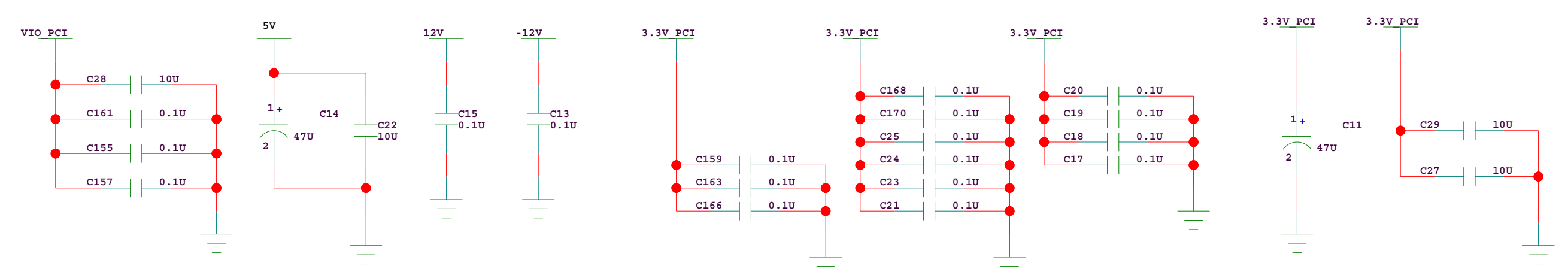
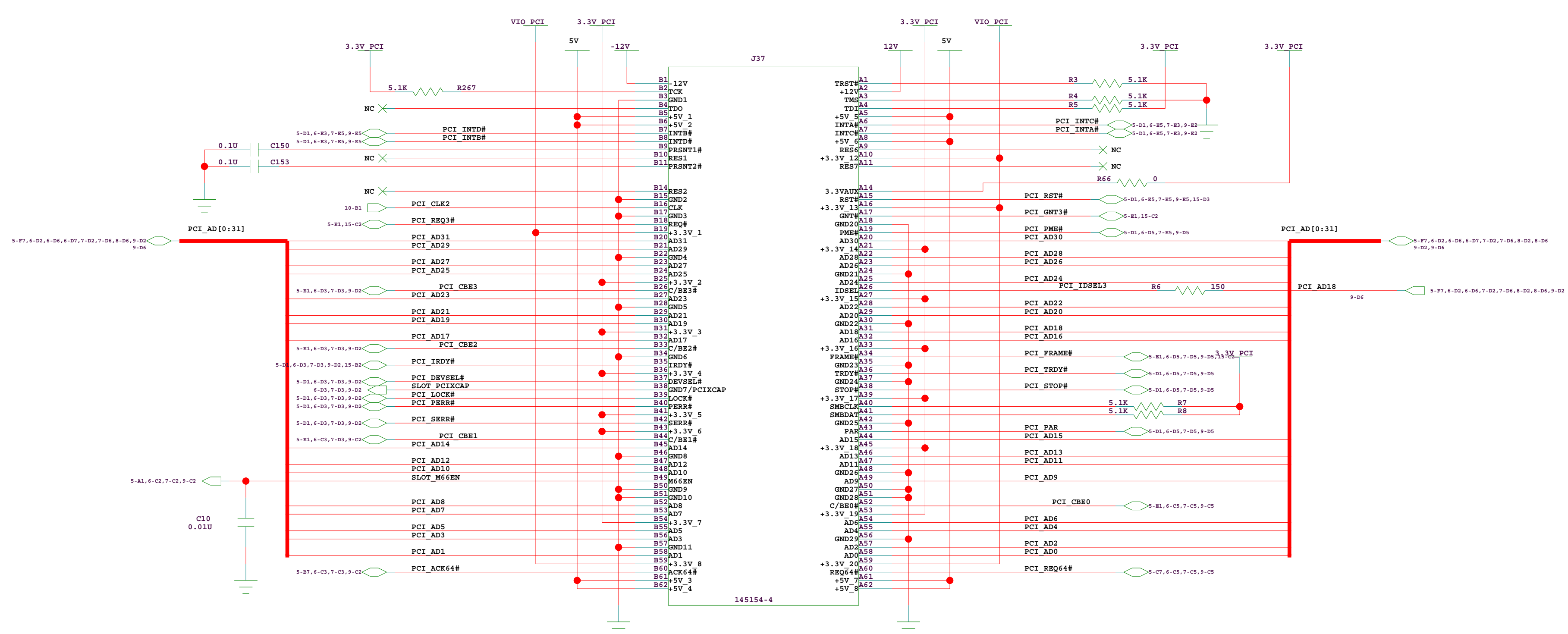



TITLE : PCI SLOT 3			
SIZE C	DRAWING NUMBER : 60E204A_SCO01_01	Version: 1.0	DESIGNER : PHILIP LAUZON
LAST MODIFIED DATE : 9-24-2007_9:40		SHEET 8 OF 15	

PCI SLOT 2 (Vertical)

IDSEL AD19
 - Required Interrupt Routing
 SLOT : BRIDGE
 INTA -> INTD
 INTB -> INTA
 INTC -> INTB
 INTD -> INTC
 - PCI Clock PCI_CLK3
 - PCI Arbitration PCI_GNT#0/PCI_REQ#0

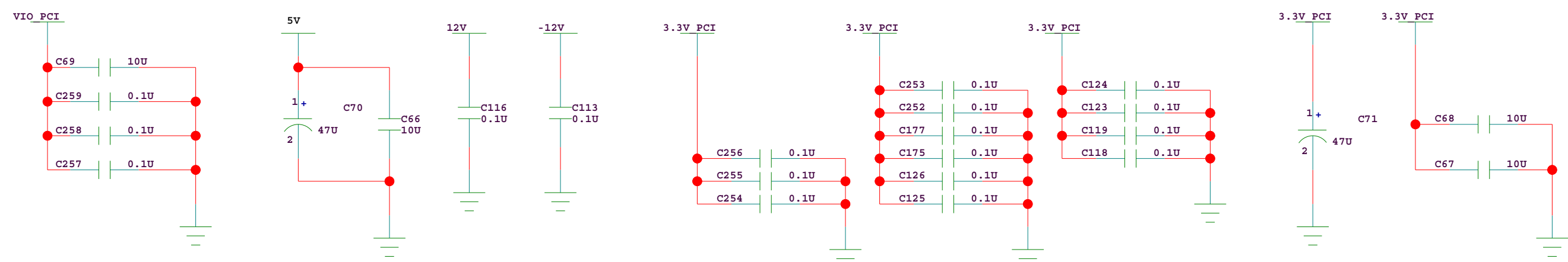
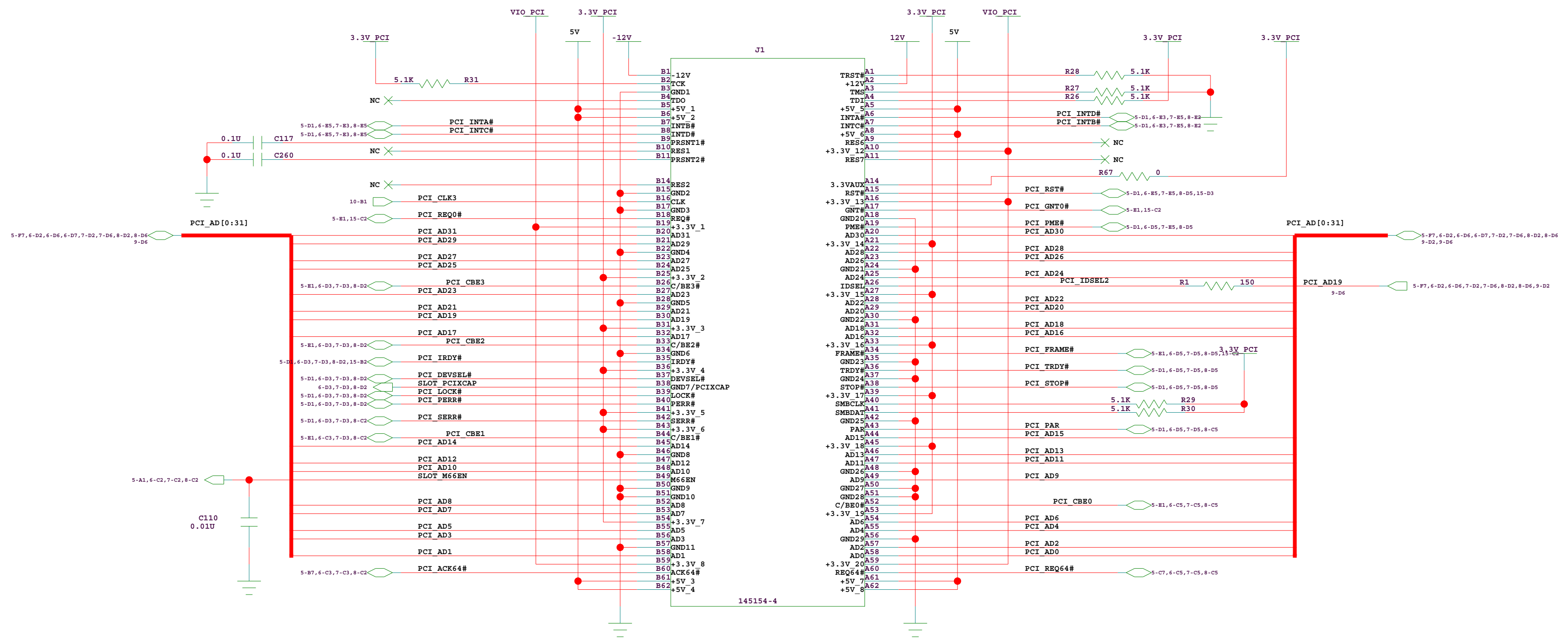

TITLE :
PCI SLOT 2

SIZE	DRAWING NUMBER :	Version:	DESIGNER :
C	60E204A_SC001_01	1.0	PHILIP LAUZON

LAST MODIFIED DATE : 9-24-2007_9:40
 SHEET 9 OF 15

CLOCK DISTRIBUTION

PCI EXTERNAL CLOCK

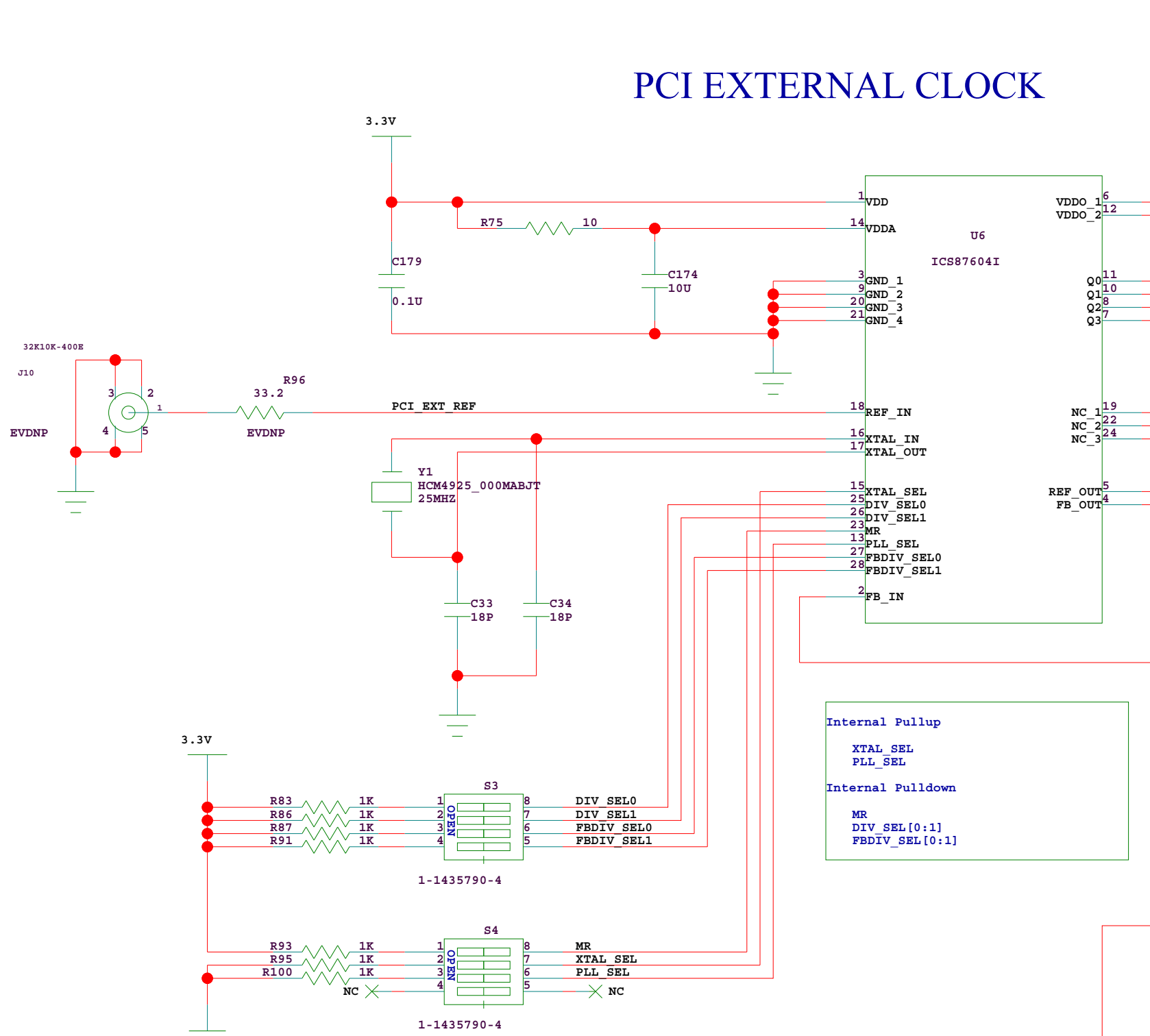

PCIe LOCAL CLOCKGEN

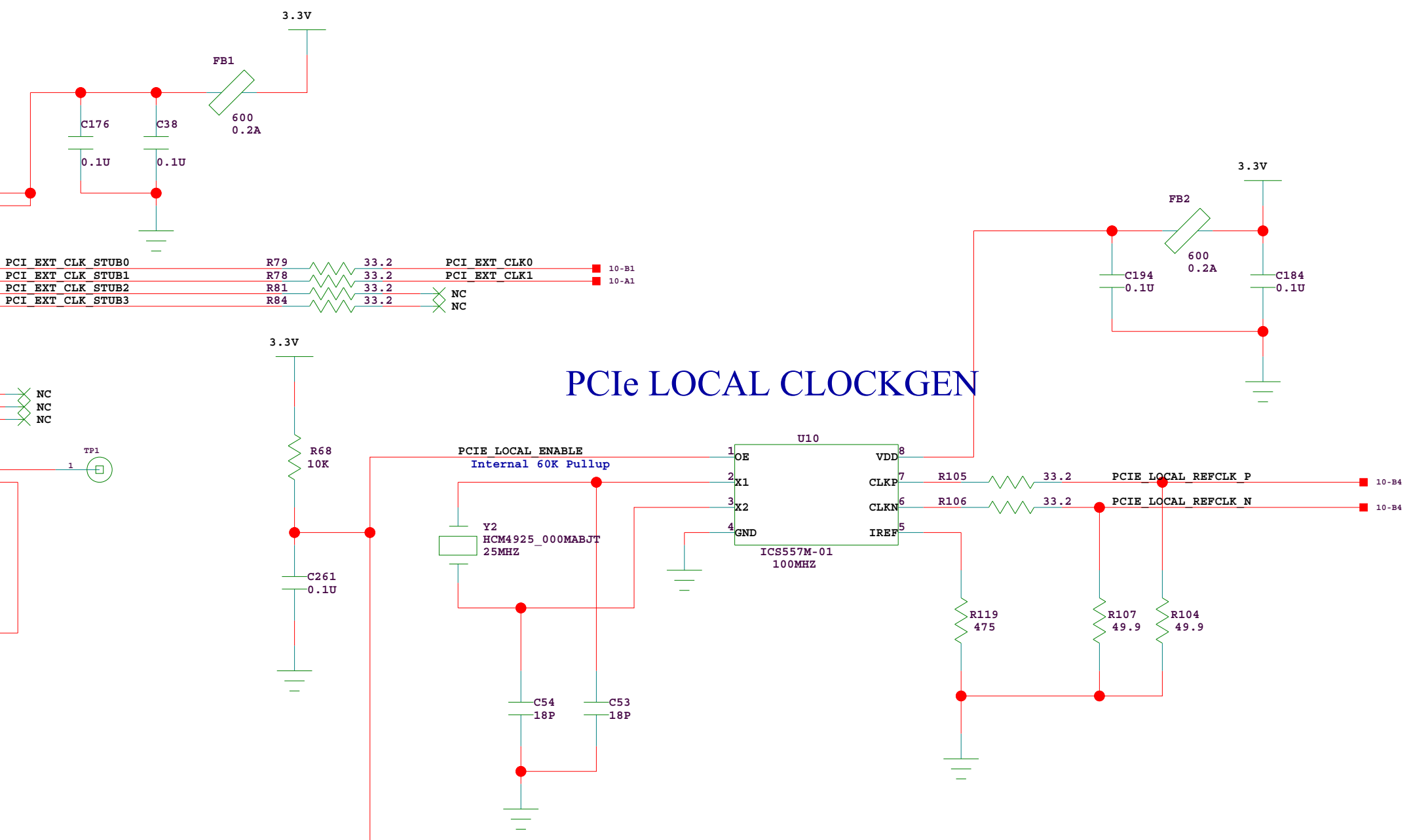

SYS/LOCAL PCIe CLOCK MULTIPLEXER

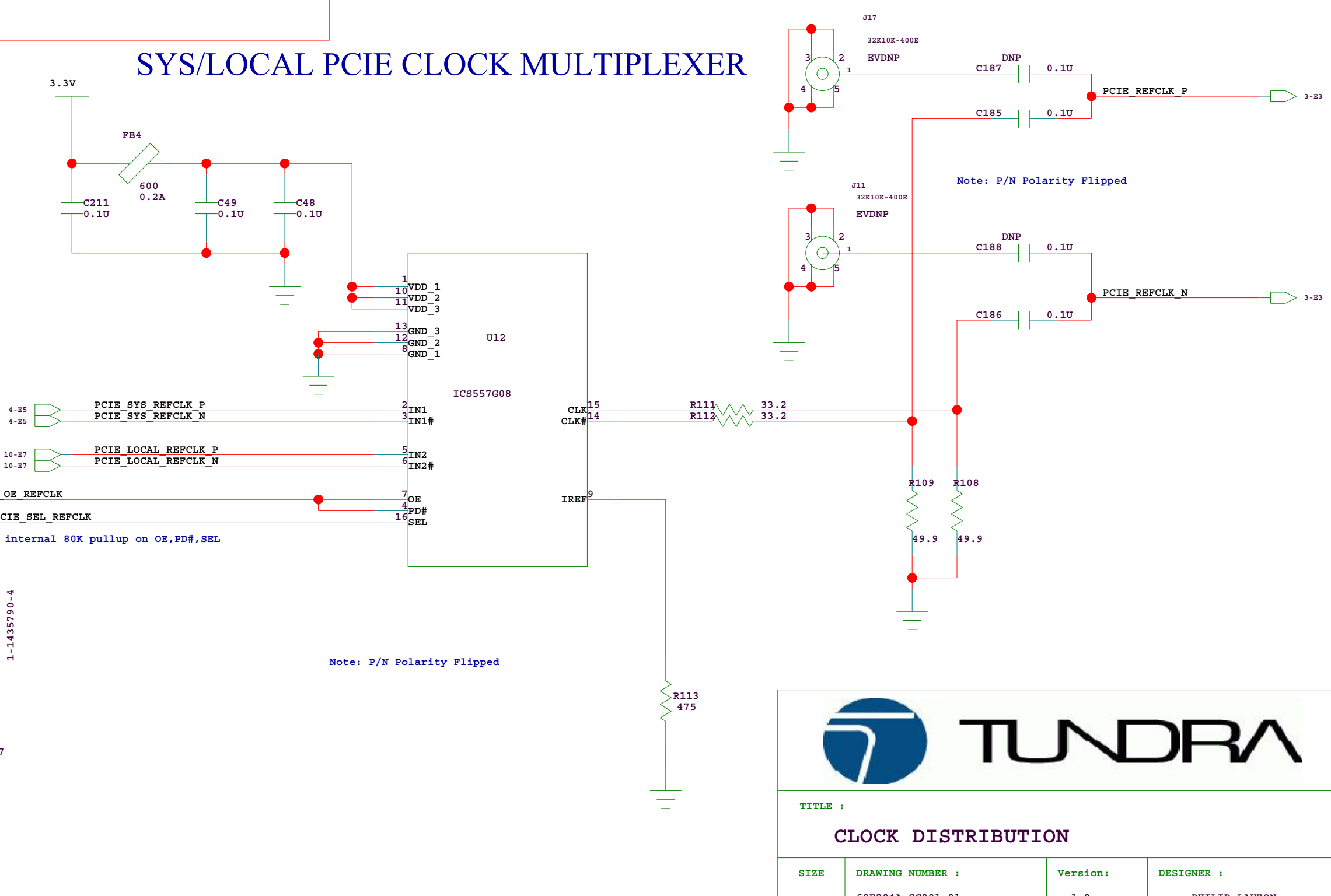

Frequency Select (ICS87604I)

FBDIV_SEL[0:1]	DIV_SEL[0:1]	OUTPUT
0:0	0:0	100Mhz
0:0	1:0	50Mhz
0:0	1:1	25Mhz
0:1	0:0	133Mhz
0:1	1:0	66Mhz
0:1	1:1	33Mhz

Place resistors near CY2305

TUNDRA

TITLE :
CLOCK DISTRIBUTION

SIZE C	DRAWING NUMBER : 60E204A_SC001_01	Version: 1.0	DESIGNER : PHILIP LAUZON
LAST MODIFIED DATE : 9-24-2007_9:44		SHEET 10 OF 15	

TSI382A POWER/REGULATORS

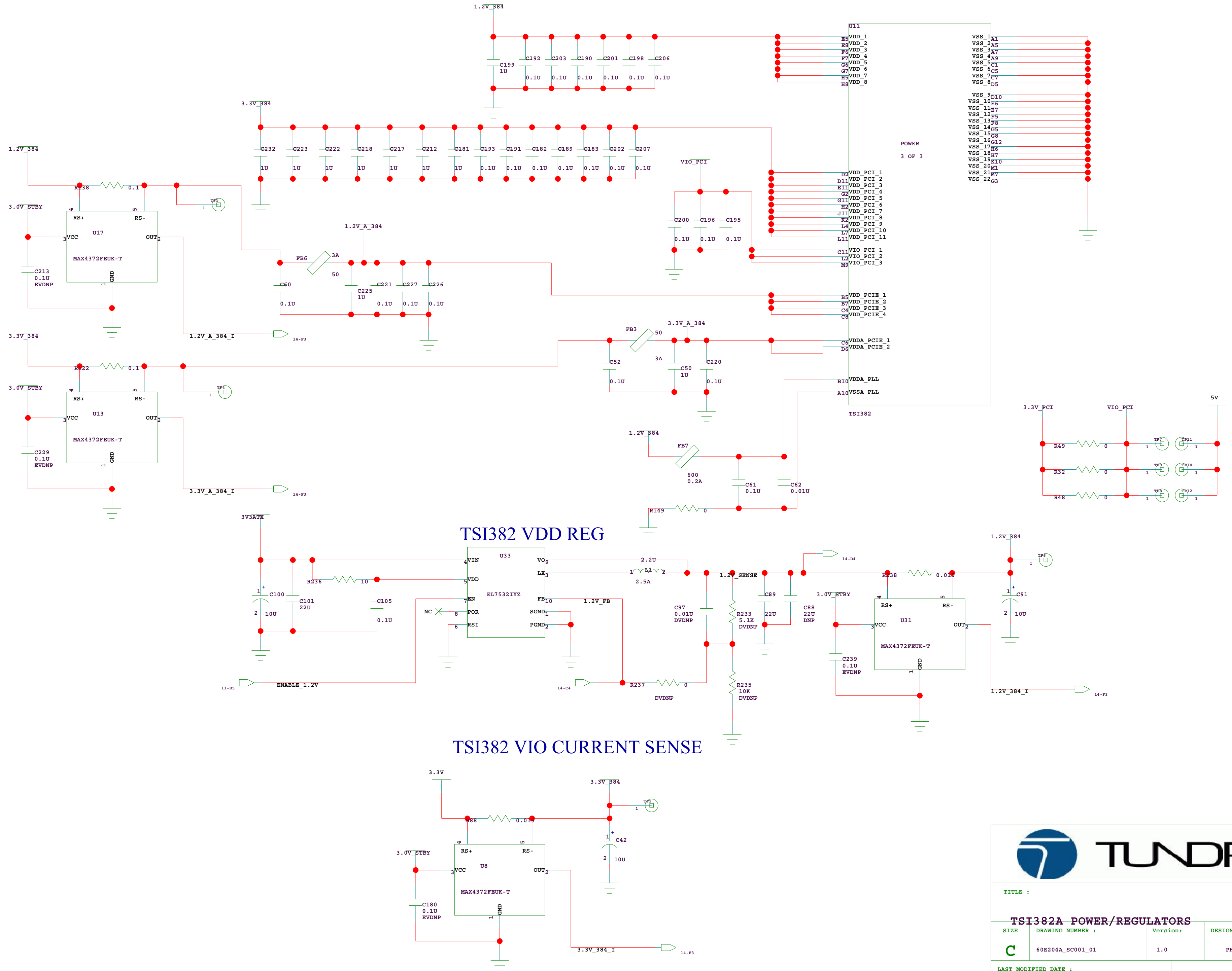

TITLE :			
TSI382A POWER/REGULATORS			
SIZE	DRAWING NUMBER :	Version:	DESIGNER :
C	60E204A_SC001_01	1.0	PHILIP LAUZON
LAST MODIFIED DATE :			SHEET
9-24-2007_9:40			12 OF 15

PCI POWER REGULATORS

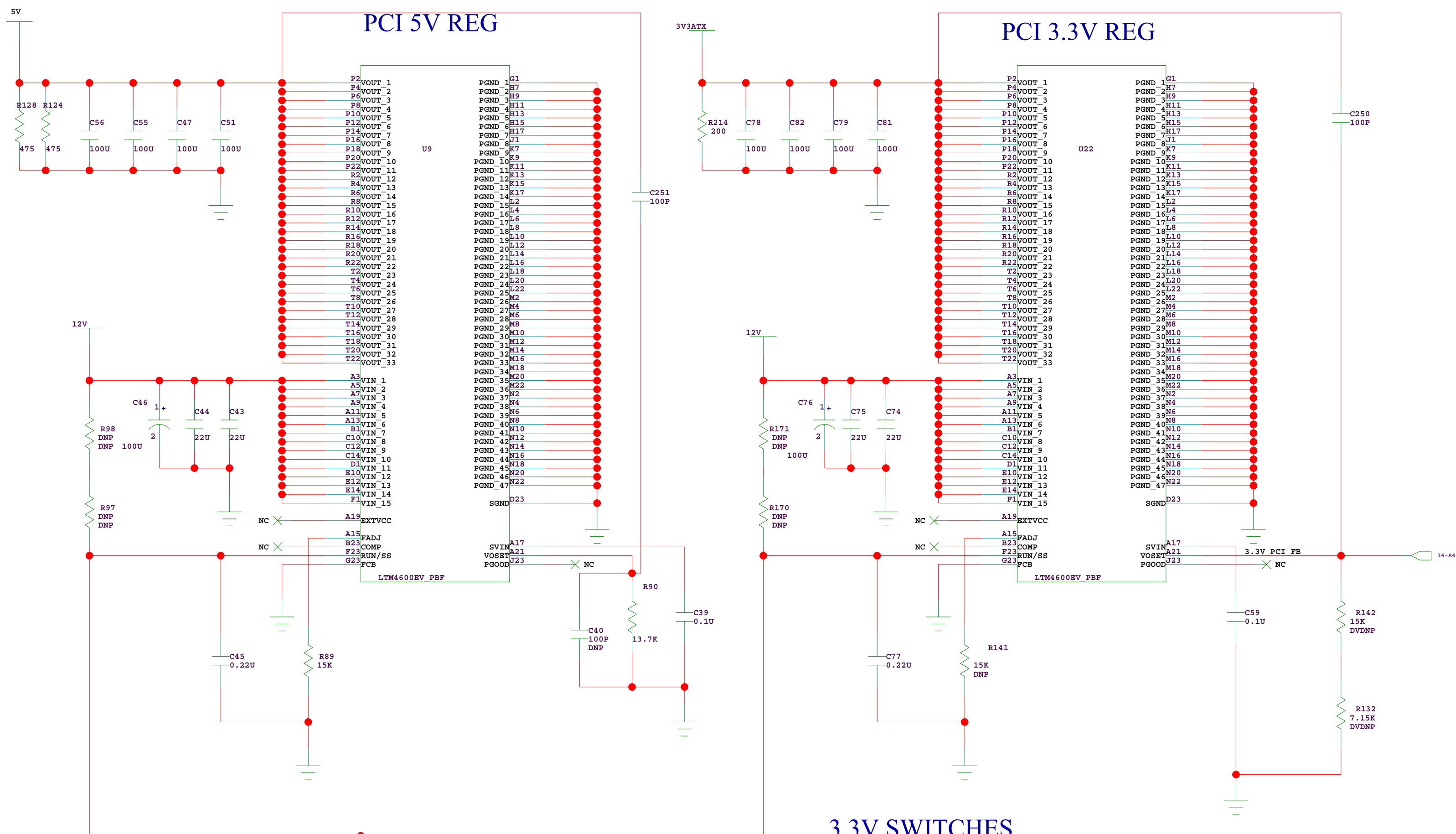

3.3V SWITCHES

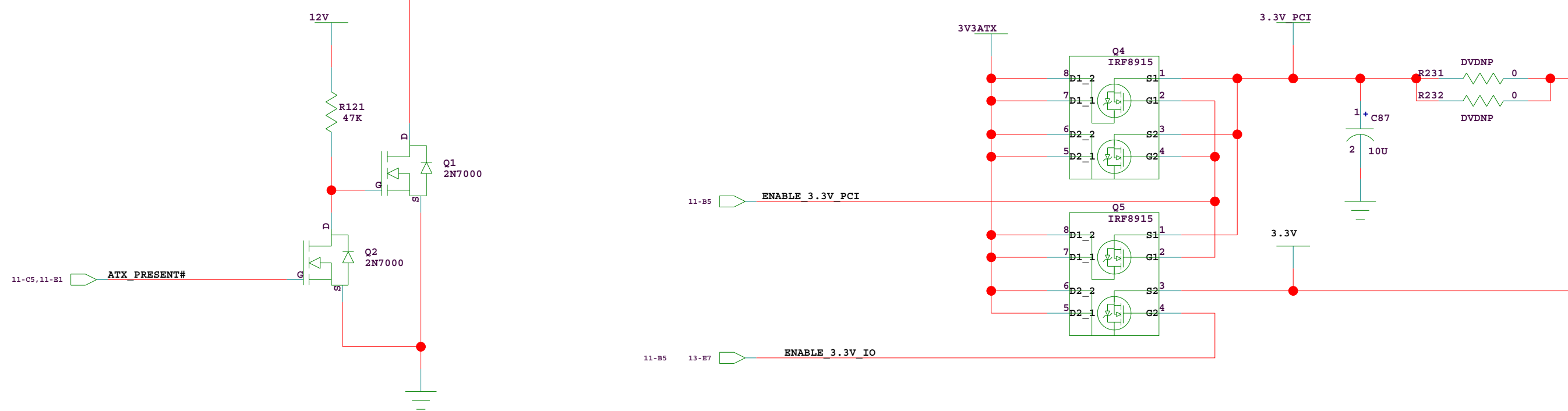

TITLE : PCI POWER REGULATORS			
SIZE C	DRAWING NUMBER : 60E204A_SC001_01	Version: 1.0	DESIGNER : PHILIP LAUZON
LAST MODIFIED DATE : 9-24-2007_9:40		SHEET 13 OF 15	

TEST DEVICES

TSI382 V/I ADC

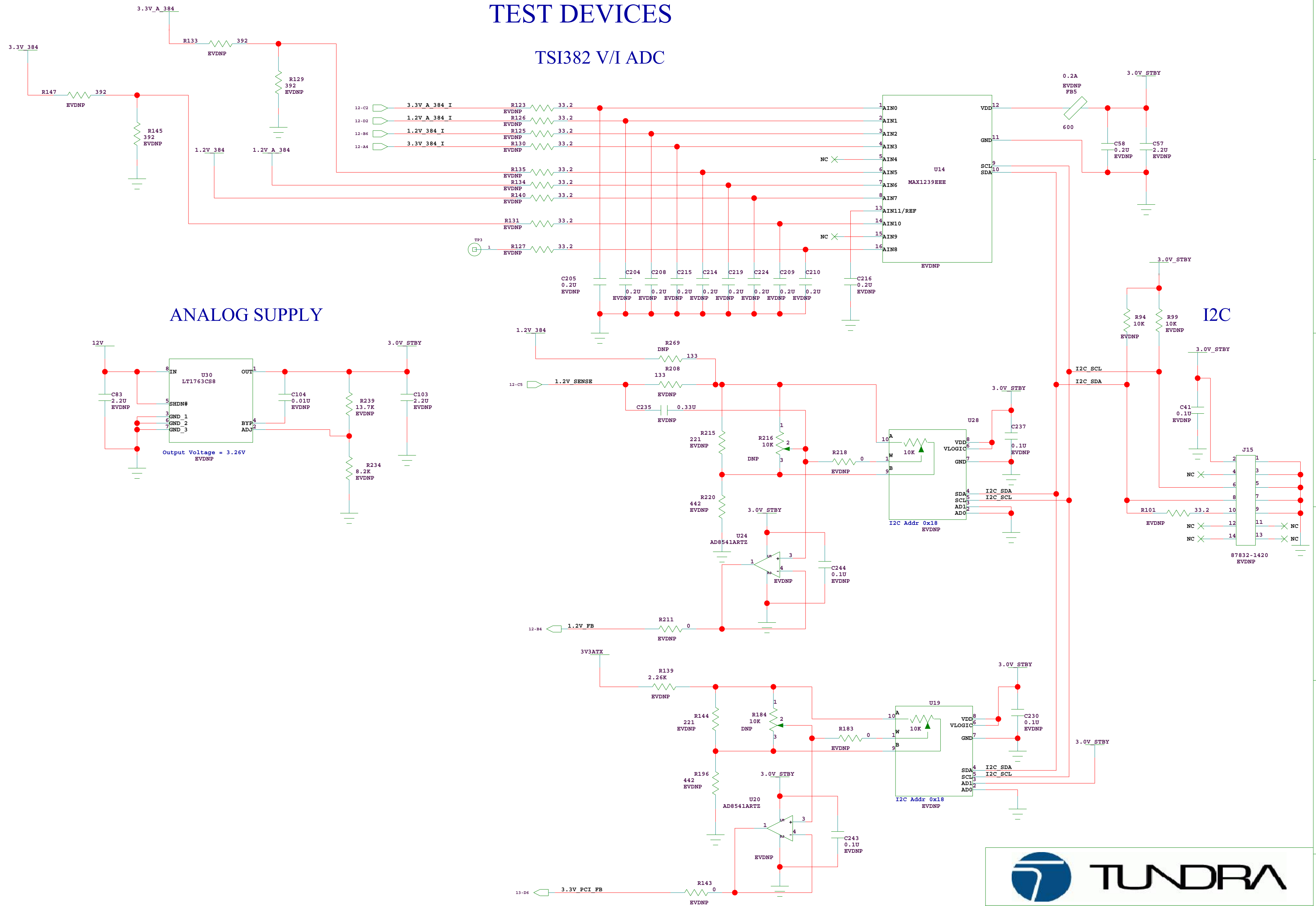

TITLE :			
TEST DEVICES			
SIZE	DRAWING NUMBER :	Version:	DESIGNER :
C	60E204A_SCO01_01	1.0	PHILIP LAUZON
LAST MODIFIED DATE :			SHEET
10-3-2007_16:33			14 OF 15

TEST DEVICES CONT'D

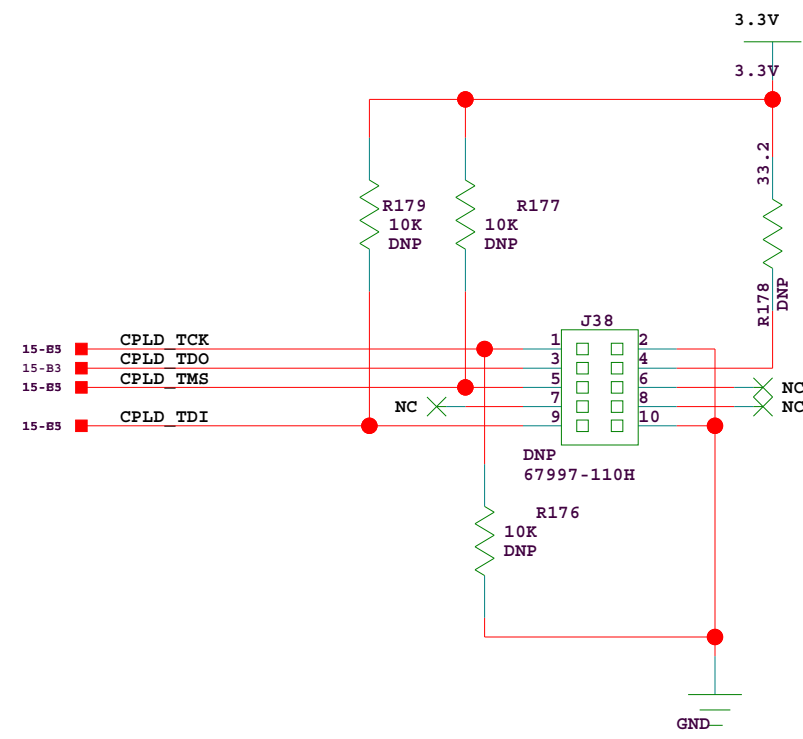

PCIARBITER/GPIO CONTROL

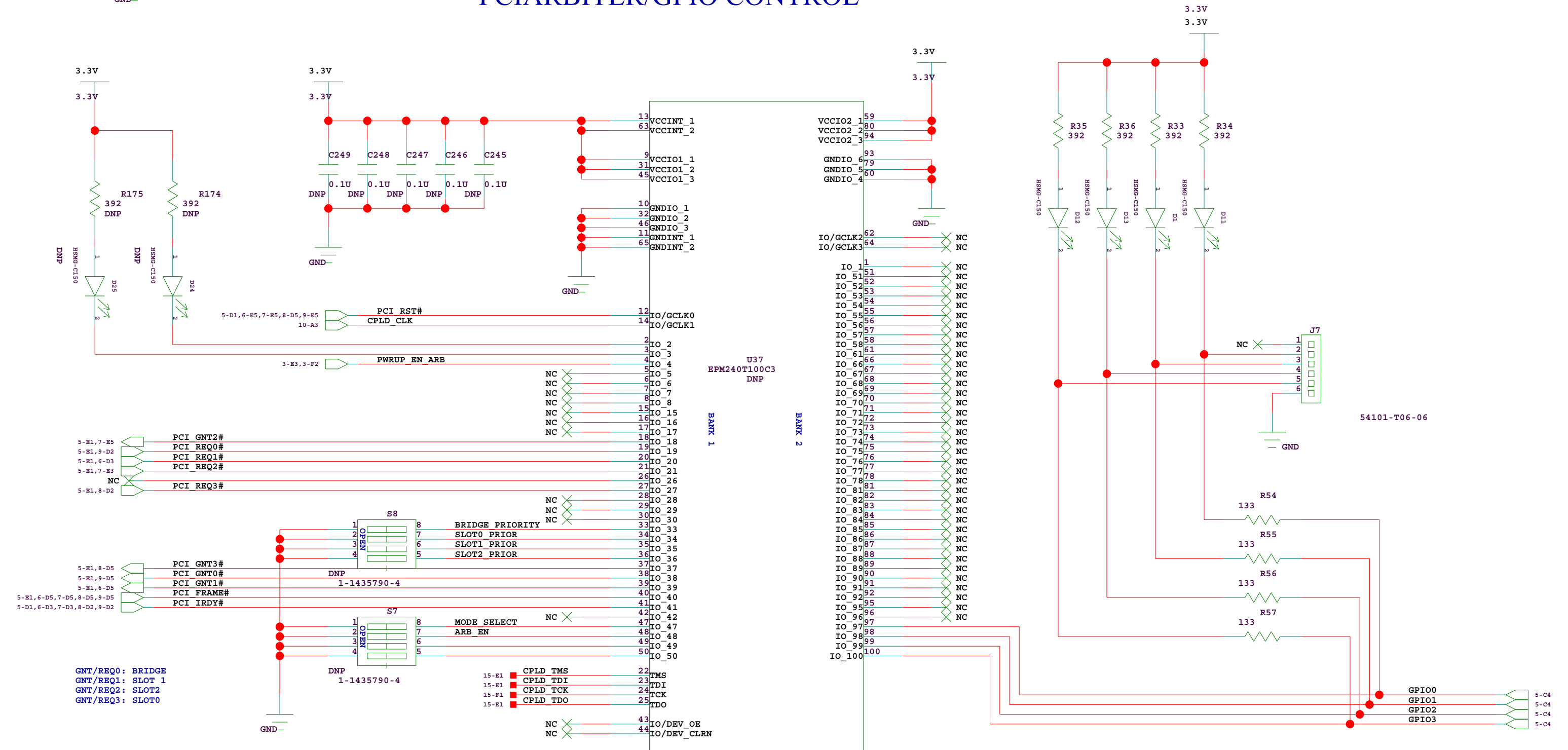

TITLE :			
TEST DEVICES CONT'D			
SIZE	DRAWING NUMBER :	Version:	DESIGNER :
C	60E204A_SCO01_01	1.0	PHILIP LAUZON
LAST MODIFIED DATE :		SHEET	
9-24-2007_9:40		15 OF 15	