

Only 4 thermal vias needed.

9ZML1232

Place at pin.

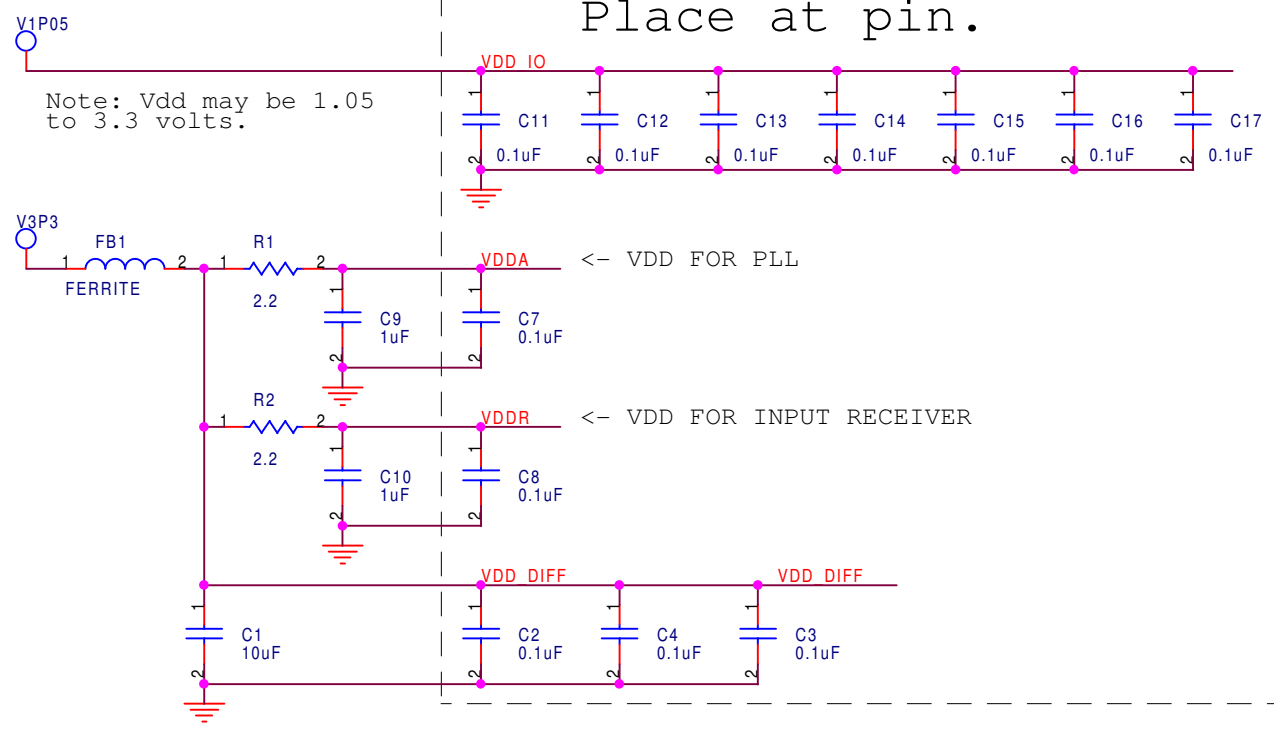

Note: Vdd may be 1.05 to 3.3 volts.

Tri-Level		
SMB_A1	SMB_A0	Add
0	0	D8
0	M	DA
0	1	DE
M	0	C2
M	M	C4
M	1	C6
1	0	CA
1	M	CC
1	1	CE

HiBW	BypM	LoBW#	MODE
Low			PLL Lo BW
Mid			Bypass
High			PLL Hi BW

Revision history	
Rev	Change
0.1	First publication

NOTE: FERRITE BEADS =

Manufacture	Part Number	Z@100MHz	PkgSz	DC res.	Current (Ma)
muRata	BLM21A601R	600	0805	0.30	600
TDK	MMZ2012S601A	600	0805	0.30	600
STEWART	HZ0805E601R	600	0805	0.30	600
AssocCmpTch	CBG0805-600-50	600	0805	0.30	600

Impedance dependent resistor values

Resistor	Zdiff = 100 ohm	Zdiff = 85 ohm
Series	33 5%	27 5%

Integrated Device Technology
6024 Silver Creek Valley Road
San Jose, CA

Title		9ZML1232 Power Filter	
Size	Document Number	Rev	0.1
Date:	Tuesday, March 19, 2013	Sheet	1 of 1