

Technical Data of Ceramic Resonator

MURATA Part No.: CSTLS4M00G56-B0

Applied to R5F21256SNFP(High)



TOYAMA MURATA MANUFACTURING CO., LTD.

Product Engineering Service Section VI

Piezoelectric Components Department I

Piezoelectric Components Division

Device Business Unit

Approved by	Checked by	Issued by	Issued Date	Data No.
 K.Maruno	 R.Miyamae	 T.Morita	Nov 22, 2005	TCD-05-1672

Contents

1.	Test Circuit	1
2.	Temperature Characteristics of Oscillating Frequency, Oscillating Voltage	2
3.	Rise Time, Oscillating Frequency, Oscillating Voltage vs Vcc Characteristics	3

Note : Rise Time

"Rise time" is defined as the time when oscillation voltage reaches 90% of full voltage swing after Vdd(Vset) is supplied.

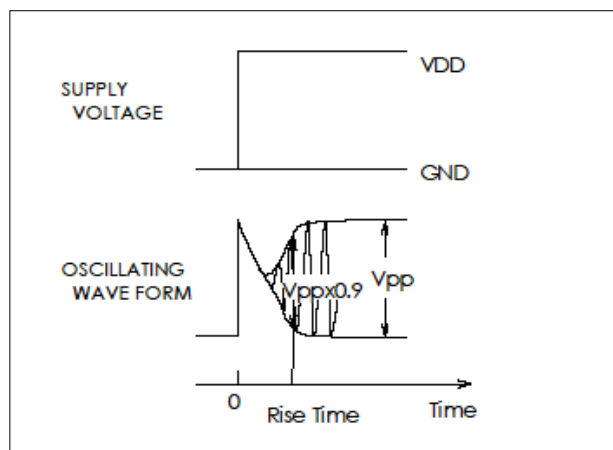

In the case that rising time of Vdd(Vset) is slow comparing to resonator's rise time due to the bypass capacitor, resonator's rise time is also slow because it depends on rising time of Vdd(Vset).

Also, in the case that the time supplying voltage to the oscillator circuit takes a certain time by reset time etc after Vdd(Vset) is applied, resonator's rise time is also slow.

In these case, we will describe "Unable to measure" in rise time data, because we can not measure resonator's rise time correctly.

Test Circuit

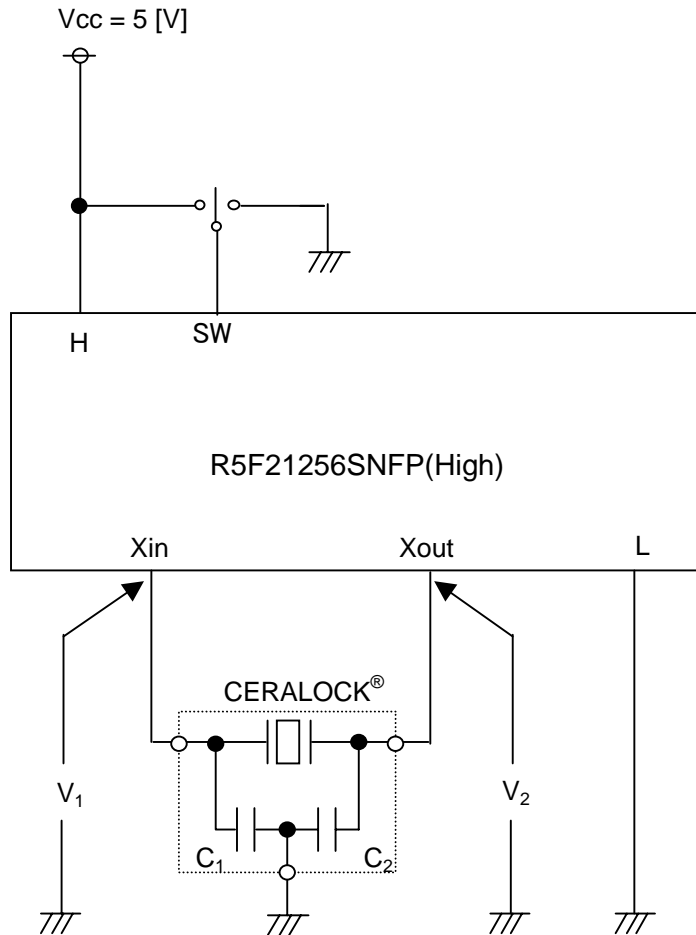

SEL	RESET 8pin	P1_7/TRAIO/ $\overline{\text{INT1}}$ 21pin	P4_5/ $\overline{\text{INT0}}$ 27pin
SW	L→H	H	H→L

Xin : 11
 Xout: 9
 H : 5, 12
 L : 10

Recommended Value

CERALOCK[®] : CSTLS4M00G56-B0

Vcc = 2.6 to 5.5 [V]

C1 = 47 [pF] (Typ.)

C2 = 47 [pF] (Typ.)

Ta = -40 to 85 [°C]

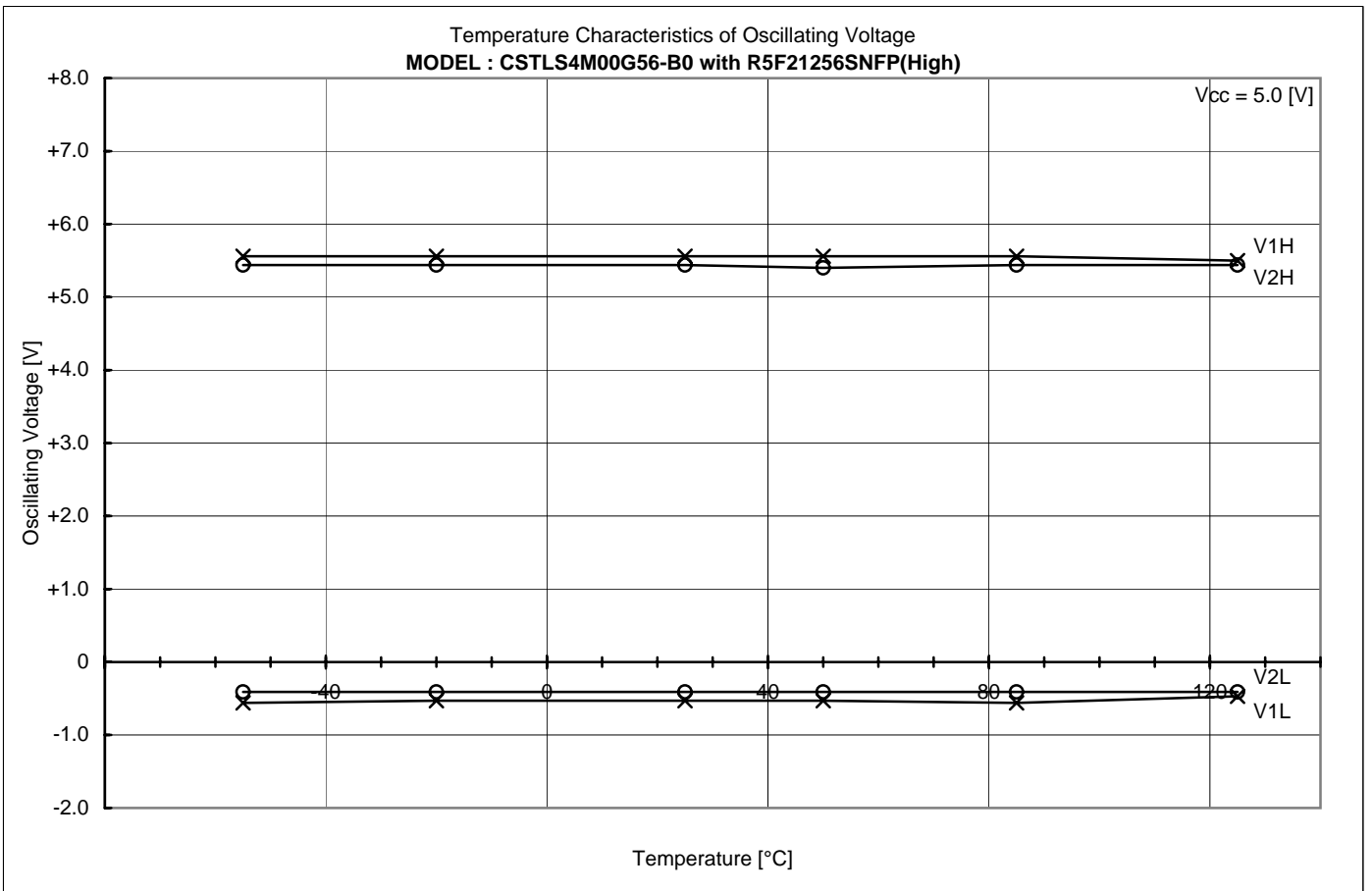
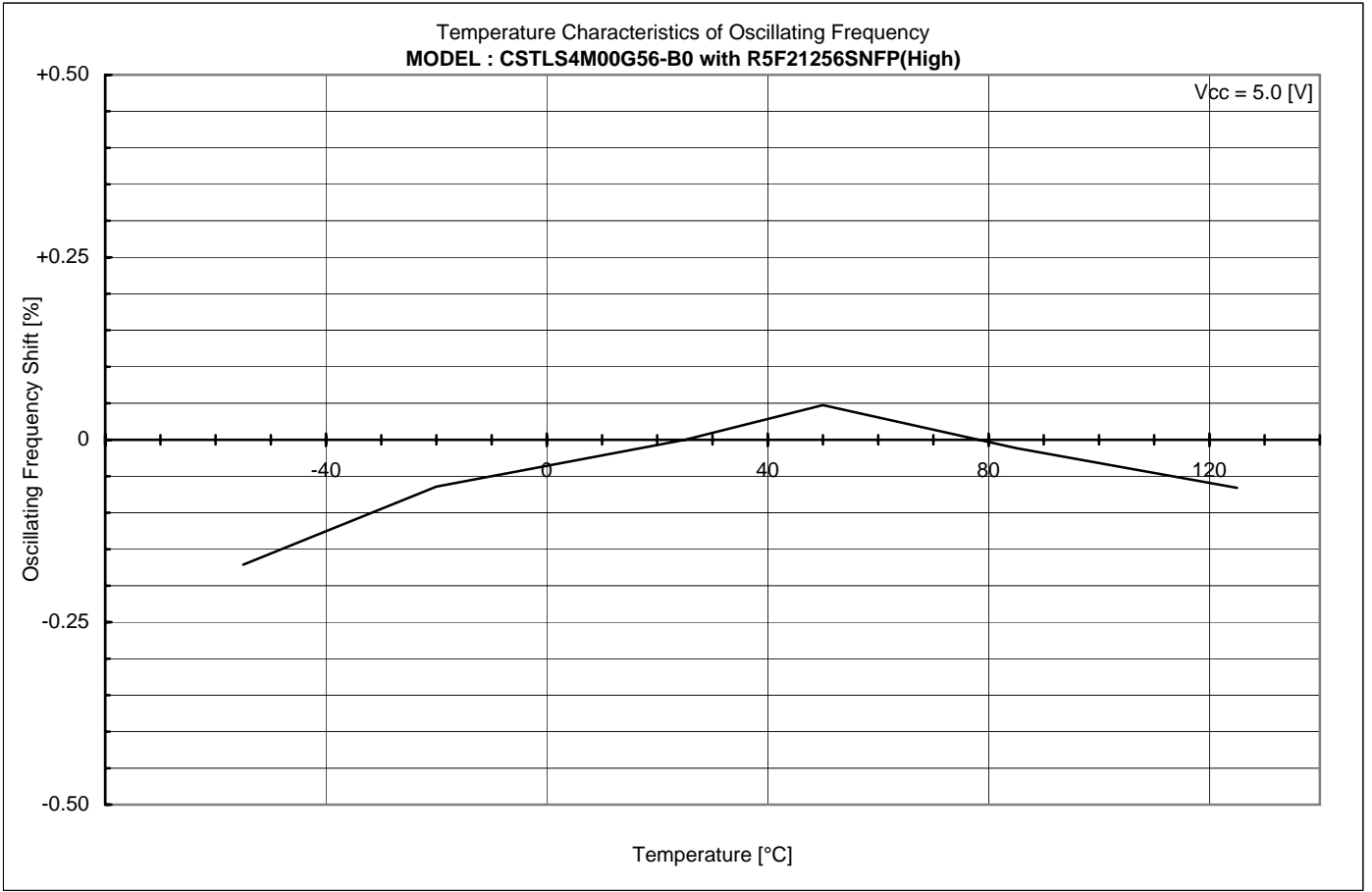

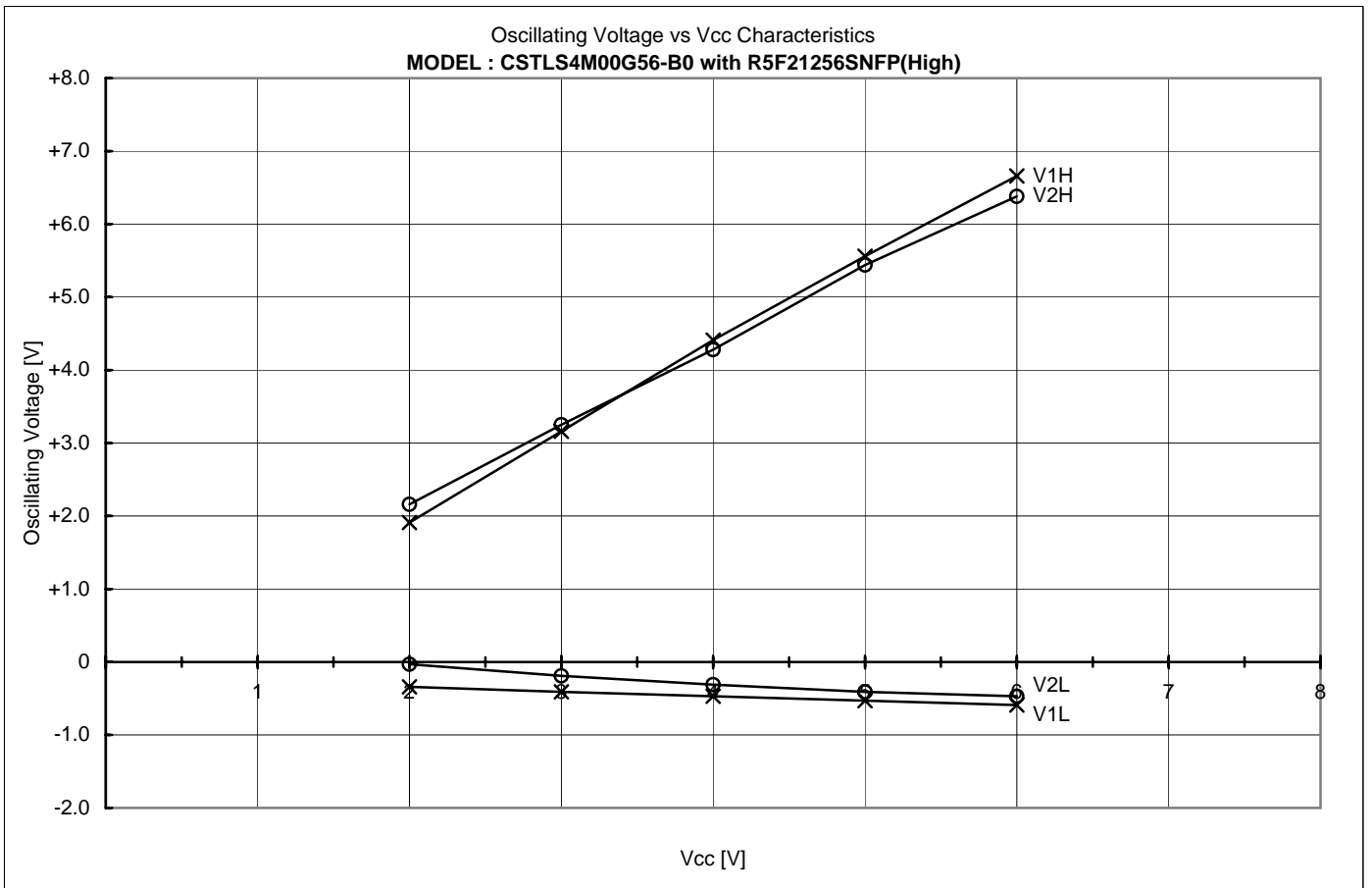
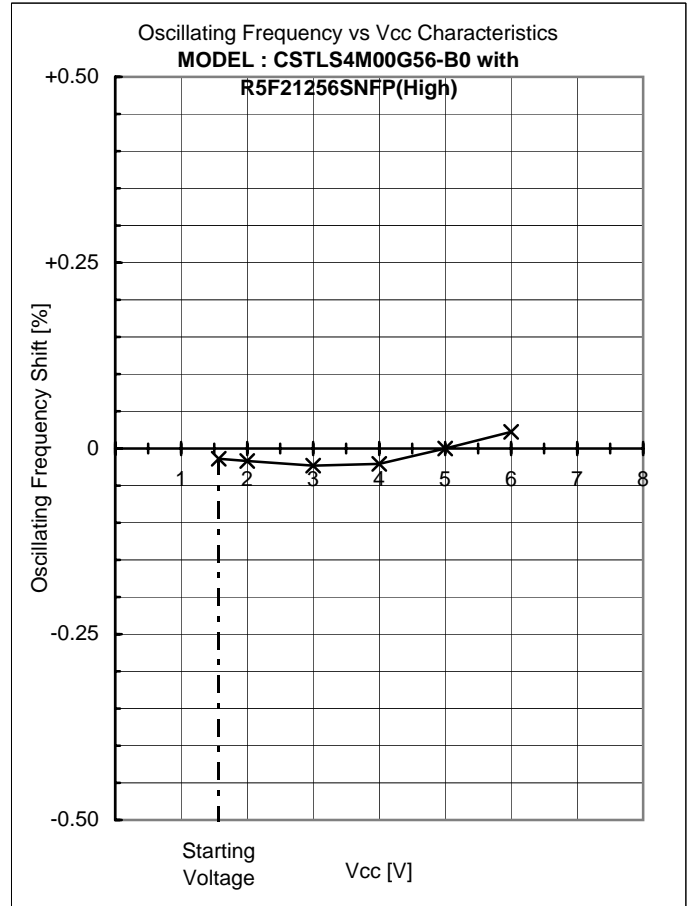
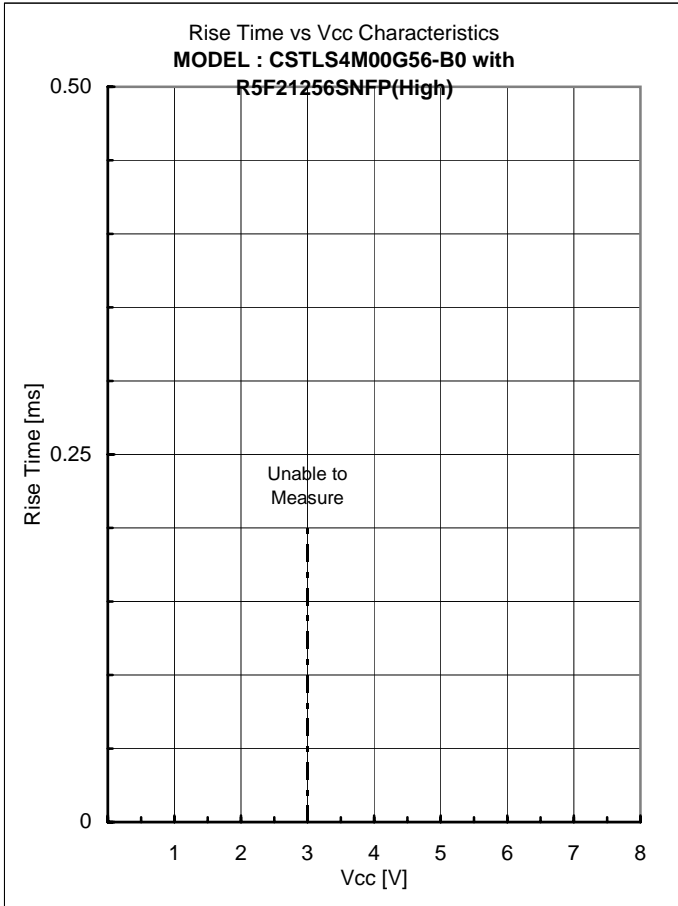

Appendixes

4. Comparison Table

4

Comparison Table

IC : No	V1H [V]	V1L [V]	V1p-p [V]	V2H [V]	V2L [V]	V2p-p [V]	Fosc [kHz]	Trise [ms]	Vstart [V]
WS	5.56	-0.53	6.09	5.44	-0.41	5.85	4012.039	Unable to	1.57
LL	5.53	-0.47	6.00	5.41	-0.44	5.85	4012.125	Measure	1.42
LH	5.53	-0.53	6.06	5.44	-0.38	5.82	4011.579		1.54
HH	5.59	-0.50	6.09	5.44	-0.44	5.88	4011.944		1.56
HL	5.59	-0.47	6.06	5.38	-0.44	5.82	4012.100		1.56

Ref.

Performance described page 2 to 3 were measured with IC No. WS

Frequency Correlation Data

Sample No.	R5F21256SNFP(High) Fosc [kHz]	TC74HCU04 Fosc [kHz]	Shift [%]
1	4013.469	4008.732	0.1182
2	4014.201	4008.863	0.1332
3	4014.969	4010.204	0.1188
4	4014.097	4009.199	0.1222
5	4011.749	4006.966	0.1194
- X	4013.697	4008.793	0.1223

muRata Standard Circuit

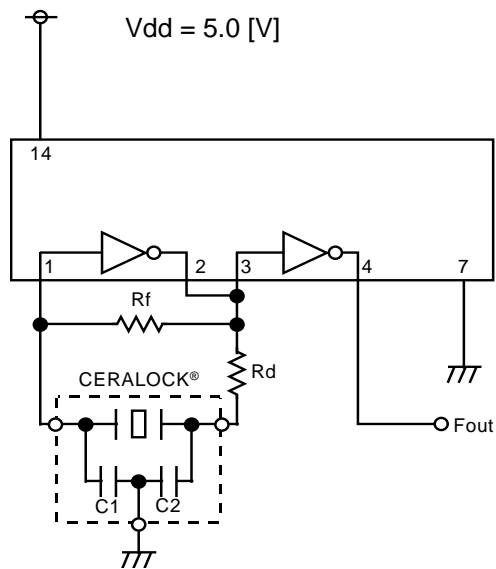

CERALOCK® : CSTLS4M00G56-B0

C1 = 47 [pF]

C2 = 47 [pF]

Rf = 1 [Mohm]

Rd = 680 [ohm]