

# SAWN VERSION DRAWING

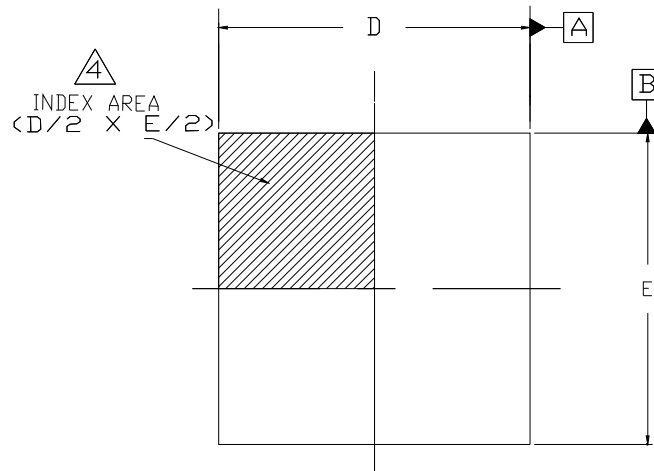

TOP VIEW

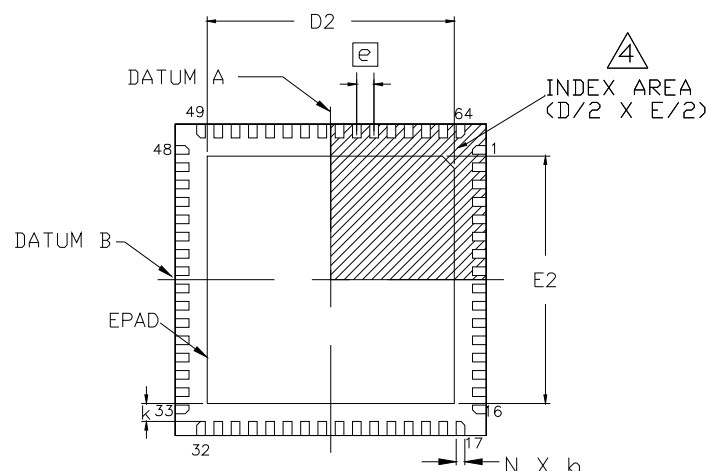

BOTTOM VIEW

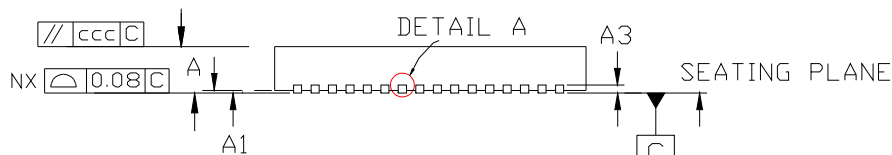

SIDE VIEW

DETAIL A

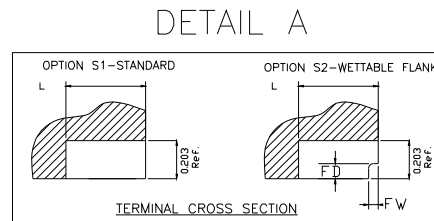

DETAIL A

Table 1: Dimensions of wettable flank

Symbol	Unit (mm)	
	MIN	MAX
FD	0.100	-
FW	0.001	0.075

**NOTES:**

1. ALL DIMENSIONING AND TOLERANCING CONFORM TO ASME Y14.5M-1994
2. ALL DIMENSIONS ARE IN MILLIMETERS.
3. N IS THE TOTAL NUMBER OF TERMINALS.
4. PIN1 INDEX ID IS INDICATED WITH EITHER EXPOSED PAD CORENER, CHAMFER OR HALF CIRCLE CUT NEAR THE EXPOSED PAD

DATE CREATED	REVISIONS		
	REV	DESCRIPTION	AUTHOR
01/12/05	00	INITIAL RELEASE	PKP
08/18/06	01	CHANGE D2 AND E2 TO FOLLOW JEDEC GUIDELINE	TU VU
09/03/08	02	ADD OPTION 2	R.TOR
01/07/09	03	ADD PUNCH VERSION PAGE 3	R.TOR
04/14/09	04	PAGE 1, OPTION 2 PAGE 3	R.TOR
05/20/09	05	ADD OPTION3 PAGE 1, OPTION2 PAGE 3	R.TOR
07/11/13	06	COR DIM L OPTION1 ADD OPTION 4 EPAD MOVE DIMENSION OPTION 1,2,3 TO PAGE 2 ADD LAND PATTERN	KS
05/20/14	07	INITIAL RELEASE	CK LEE
10/29/15	08	INITIAL RELEASE	J HUA
05/05/17	09	-ADD WETTABLE FLANK PACKAGE -UPDATE PAD EXTENDED LENGTH TO 150UM ON PAGE 3 AND 5 -UPDATE A3 TO 0.203REF -ADD DETAIL OPTION TO EPAD OPTION TABLE ON PAGE 3 AND 5 -ADD EPAD CHAMFER ON PAGE 1 AND 4	CM YEY
09/01/20	10	ADD EPAD OPTION	CM YEY
01/14/21	11	ADD EPAD OPTION	JH
06/17/21	12	ADD EPAD OPTION	JH
07/30/21	13	UPD. DIMENSIONS OF WETTABLE FLANK	JHTAN

NOTE: REFER TO DCP FOR OFFICIAL RELEASE DATE

TOLERANCES UNLESS SPECIFIED  
DECIMAL  
X± .1  
XX± .05  
XXX± .030  
ANGULAR  
±1°

6024 SILVER CREEK VALLEY ROAD. SAN JOSE, CA 95138  
PHONE: (408) 284-8200  
FAX: (408) 284-3572

TITLE: NLG64 Package Outline Drawing  
9.0 x 9.0 X 0.9 mm. Body  
0.50mm. Pitch VQFPN

SIZE	DRAWING No.	REV
C	PSC-4147	13



## SAWN VERSION DIMENSION

SYMBOL	COMMON DIMENSIONS		
	MIN.	NOM.	MAX.
A1	0.00	0.02	0.05
A3	0.203 REF.		
X	b/2	-	-
b	0.18	0.25	0.30
A	0.80	0.90	1.00
D	9.00 BSC		
E	9.00 BSC		
e	0.50 BSC		
L	0.30	0.40	0.50
N	64		
ND		16	
NE		16	
TOLERANCES OF FORM & POSITION			
bbb	0.10		
ccc	0.10		
ddd	0.05		

### EPAD OPTION

SYMBOL	P1(EPC1)			P2(EPC2)			P3(EPC3)			P4(EPC4)			P5(EPC5)			P6(EPC10)		
	MIN.	NOM.	MAX.	MIN.	NOM.	MAX.	MIN.	NOM.	MAX.	MIN.	NOM.	MAX.	MIN.	NOM.	MAX.	MIN.	NOM.	MAX.
D2	7.00	7.15	7.25	6.00	6.15	6.25	7.50	7.60	7.70	4.20	4.30	4.40	5.90	6.00	6.10	7.60	7.70	7.80
E2	7.00	7.15	7.25	6.00	6.15	6.25	7.50	7.60	7.70	4.20	4.30	4.40	5.90	6.00	6.10	7.60	7.70	7.80
k	0.525 REF.			1.025 REF.			0.30 REF.			1.95 REF.			1.10 REF.			0.25 REF.		
DETAIL A	S1			S1			S1			S1			S1			S1		

SYMBOL	P7(EPC11)			P8(EPC12)		
	MIN.	NOM.	MAX.	MIN.	NOM.	MAX.
D2	5.10	5.20	5.30	5.00	5.10	5.20
E2	5.10	5.20	5.30	5.00	5.10	5.20
k	1.50 REF.			1.55 REF.		
DETAIL A	S1			S1		

SYMBOL	S2(EPC9)(WETTABLE FLANK)		
	MIN.	NOM.	MAX.
D2	7.60	7.70	7.80
E2	7.60	7.70	7.80
k	0.25 REF.		
DETAIL A	S2		

TOLERANCES  
UNLESS SPECIFIED  
DECIMAL  
X± .1  
XX± .05  
XXX± .030  
ANGULAR  
±1°

**RENESAS**

6024 SILVER CREEK  
VALLEY ROAD, SAN JOSE,  
CA 95138  
PHONE: (408) 284-8200  
FAX: (408) 284-3572

TITLE: NLG64 Package Outline Drawing  
9.0 x 9.0 X 0.9 mm. Body  
0.50mm. Pitch VFQFPN

SIZE	DRAWING No.	REV
C	PSC-4147	13

DO NOT SCALE DRAWING

SHEET 2 OF 5

# SAWN VERSION RECOMMENDED LAND PATTERN

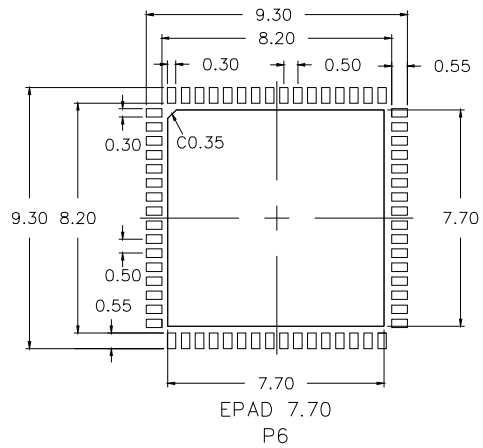
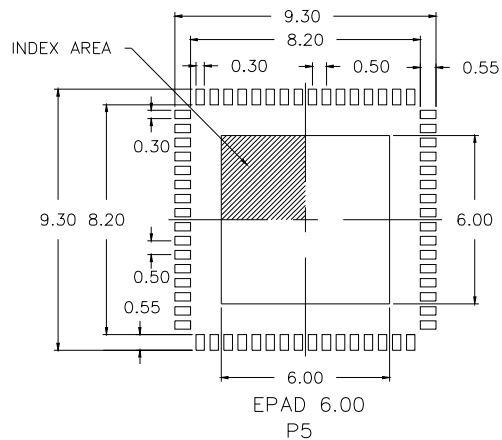
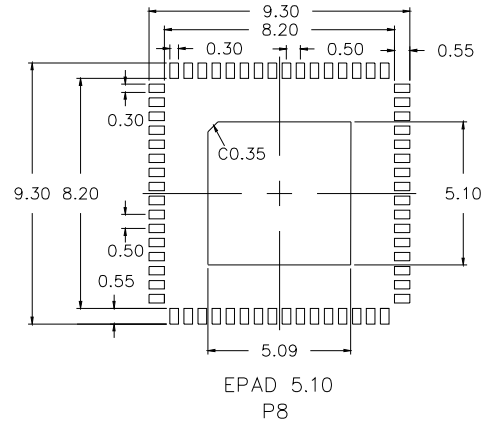
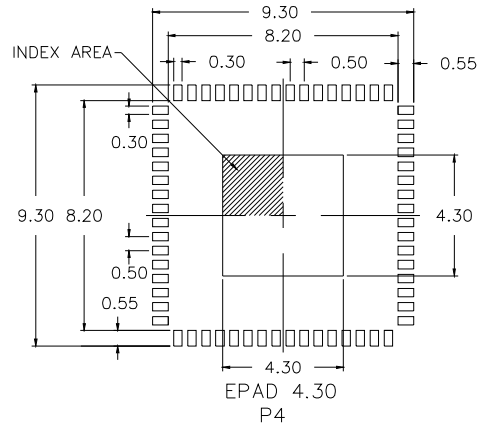
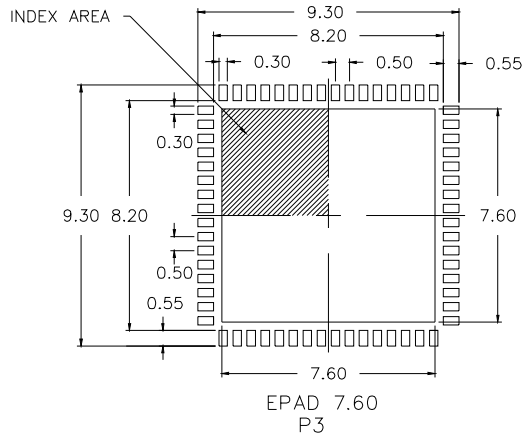
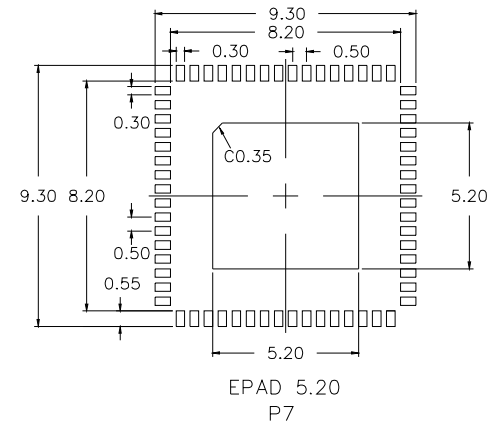
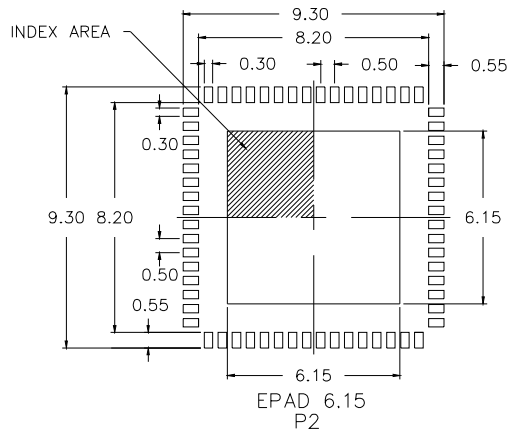
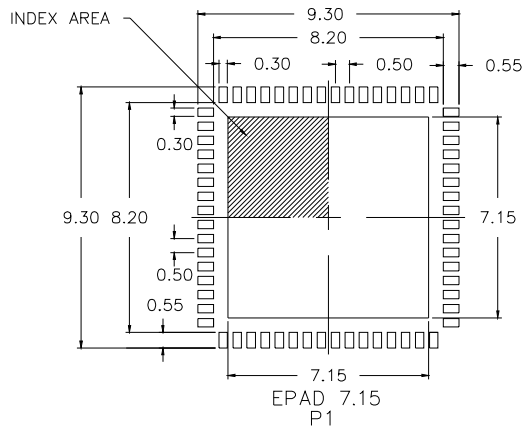

TOLERANCES  
UNLESS SPECIFIED  
DECIMAL  
X± .1  
XX± .05  
XXX± .030  
ANGULAR  
±1°

**RENESAS**

6024 SILVER CREEK  
VALLEY ROAD, SAN JOSE,  
CA 95138  
PHONE: (408) 284-8200  
FAX: (408) 284-3572

TITLE: NLG64 Package Outline Drawing  
9.0 x 9.0 X 0.9 mm. Body  
0.50mm. Pitch VFQFPN

SIZE <b>C</b>	DRAWING No. PSC-4147	REV 13
------------------	-------------------------	-----------

DO NOT SCALE DRAWING

SHEET 3 OF 5

# PUNCH VERSION DRAWING AND DIMENSION

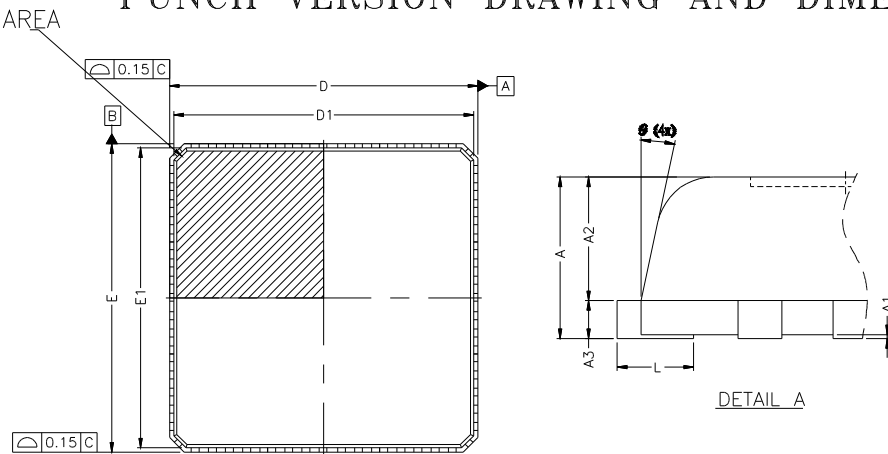

TOP VIEW

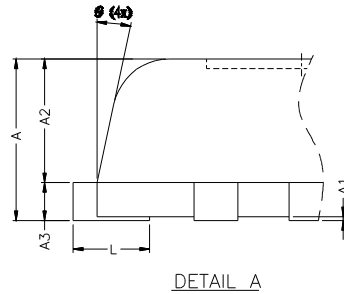

DETAIL A

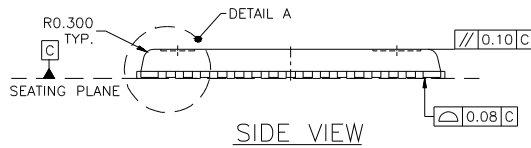

SIDE VIEW

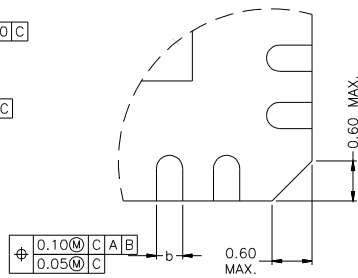

DETAIL B

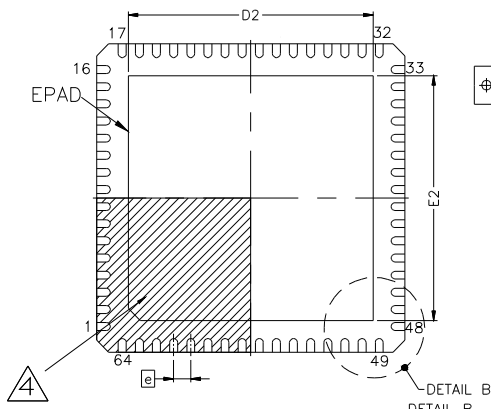

BOTTOM VIEW

SYMBOL	COMMON DIMENSIONS		
	MIN.	NOM.	MAX.
A	0.80	0.85	1.00
A1	0.00	0.02	0.05
A2	-	0.65	1.00
A3	-	0.20	-
b	0.18	0.25	0.30
D	9.00 BSC		
D1	8.75 BSC		
E	9.00 BSC		
E1	8.75 BSC		
e	0.50 BSC		
L	0.30	0.40	0.50
θ	0°	-	14°

## EPAD OPTION

SYMBOL	D1(EPC6)			D2(EPC7)			D3(EPC8)		
	MIN.	NOM.	MAX.	MIN.	NOM.	MAX.	MIN.	NOM.	MAX.
D2	7.00	7.15	7.25	6.00	6.15	6.25	5.90	6.00	6.10
E2	7.00	7.15	7.25	6.00	6.15	6.25	5.90	6.00	6.10
k	0.525 REF.			1.025 REF.			1.100 REF.		
DETAIL A	S1			S1			S1		

## NOTES:

1. ALL DIMENSIONING ARE IN MM, ANGLES IN DEGREES.
2. TOP DOWN VIEW AS VIEWED ON PCB.
3. LAND PATTERN IN BLUE NSMD PATTERN ASSUMED
4. LAND PATTERN RECOMMENDATION PER IPC-7315B LP CALCULATOR.

## NOTES:

1. REFER TO JEDEC STD: MO-220.
2. DIMENSION "b" APPLIES TO METALIZED TERMINAL AND IS MEASURED BETWEEN 0.15mm AND 0.30mm FROM THE TERMINAL TIP. IF THE TERMINAL HAS OPTIONAL RADIUS ON THE OTHER END OF THE TERMINAL, THE DIMENSION B SHOULD NOT BE MEASURED IN THAT RADIUS AREA.

TOLERANCES  
UNLESS SPECIFIED  
DECIMAL  
X± .1  
XX± .05  
XXX± .030  
ANGULAR  
±1°

**RENESAS**

6024 SILVER CREEK  
VALLEY ROAD, SAN JOSE,  
CA 95138  
PHONE: (408) 284-8200  
FAX: (408) 284-3572

TITLE: NLG64 Package Outline Drawing  
9.0 x 9.0 X 0.9 mm. Body  
0.50mm. Pitch VQFPN

SIZE <b>C</b>	DRAWING No. PSC-4147	REV 13
------------------	-------------------------	-----------

DO NOT SCALE DRAWING

SHEET 4 OF 5

# PUNCH VERSION RECOMMENDED

## LAND PATTERN

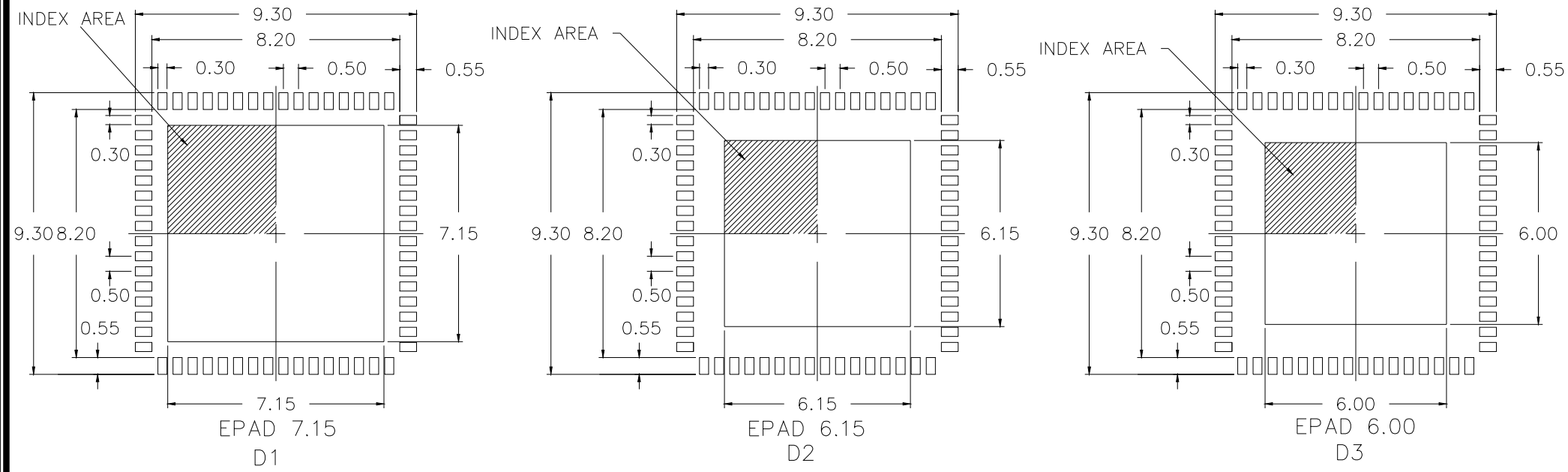

**NOTES:**

1. ALL DIMENSIONING ARE IN MM, ANGLES IN DEGREES.
2. TOP DOWN VIEW AS VIEWED ON PCB.
3. LAND PATTERN IN BLUE NSMD PATTERN ASSUMED
4. LAND PATTERN RECOMMENDATION PER IPC-7315B LP CALCULATOR.

TOLERANCES UNLESS SPECIFIED DECIMAL X± .1 XX± .05 XXX± .030 ANGULAR ±1°	6024 SILVER CREEK VALLEY ROAD, SAN JOSE, CA 95138 PHONE: (408) 284-8200 FAX: (408) 284-3572	
	<b>RENESAS</b>	
TITLE: NLG64 Package Outline Drawing 9.0 x 9.0 X 0.9 mm. Body 0.50mm. Pitch VFQFPN		
SIZE <b>C</b>	DRAWING No. PSC-4147	REV 13
DO NOT SCALE DRAWING		SHEET 5 OF 5