

REVISIONS			
REV	DESCRIPTION	DATE	APPROVED
00	INITIAL RELEASE	5/17/16	JH

INDEX AREA
(D2/2 x E/2)

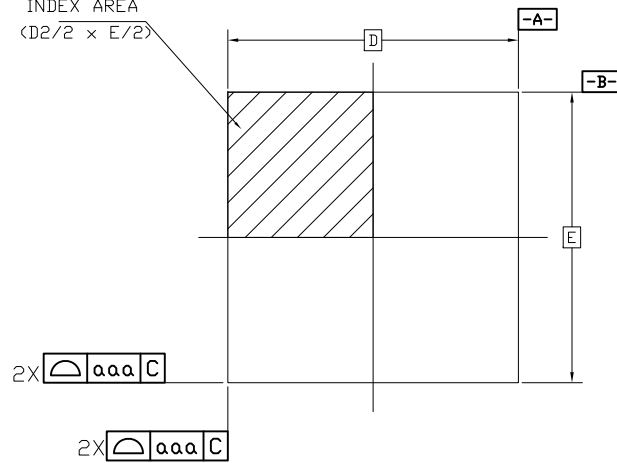

TOP VIEW

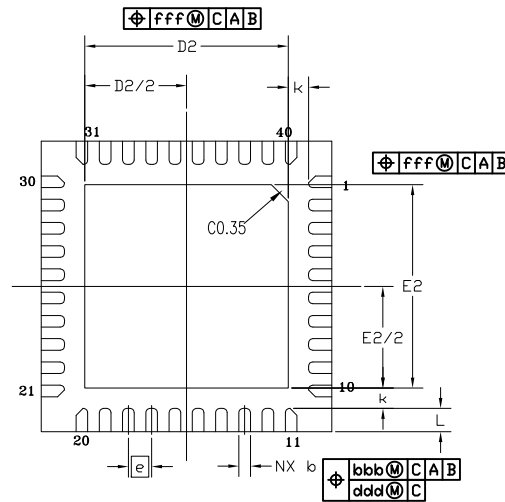

BOTTOM VIEW

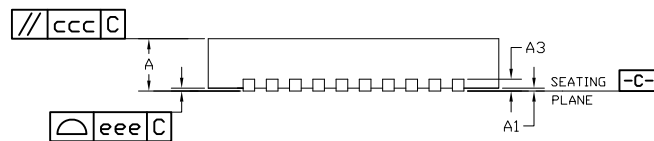

SIDE VIEW

SYMBOL	DIMENSION		
	MIN	NOM	MAX
b	0.15	0.20	0.25
D	5.00 BSC		
E	5.00 BSC		
D2	3.40	3.50	3.60
E2	3.40	3.50	3.60
L	0.30	0.40	0.50
e	0.40 BSC		
N	40		
ND	10 (note 3)		
NE	10 (note 3)		
A	0.80	0.90	1.00
A1	0.00	0.02	0.05
A3	0.2 REF		
k	0.35 REF		
aaa	0.10		
bbb	0.07		
ccc	0.10		
ddd	0.05		
eee	0.08		
fff	0.10		

NOTES:

1. ALL DIMENSIONING AND TOLERANCING CONFORM TO ANSI Y14.5M-1982
2. ALL DIMENSIONS ARE IN MILLIMETERS.
3. ND AND NE REFER TO THE NUMBER OF TERMINALS ON EACH D AND E SIDE RESPECTIVELY.

TOLERANCES UNLESS SPECIFIED		 www.IDT.com	6024 SILVER CREEK VALLEY ROAD, SAN JOSE, CA 95138 PHONE: (408) 284-8200 FAX: (408) 284-3572	
DECIMAL	ANGULAR		TITL/NDG40 PACKAGE OUTLINE 5.0 x 5.0 mm BODY, EPAD 3.50mm SQ. 0.40 mm PITCH QFN	
X ± .1	± 1°	APPROVALS	DATE	REV
XX ± .05			05/31/10	00
XXX ± .030		CHECKED		
		SIZE	DRAWING No.	
		C	PSC-4292-02	
DO NOT SCALE DRAWING			SHEET 1 OF 2	

REVISIONS			
REV	DESCRIPTION	DATE	APPROVED
00	INITIAL RELEASE	5/17/16	JH

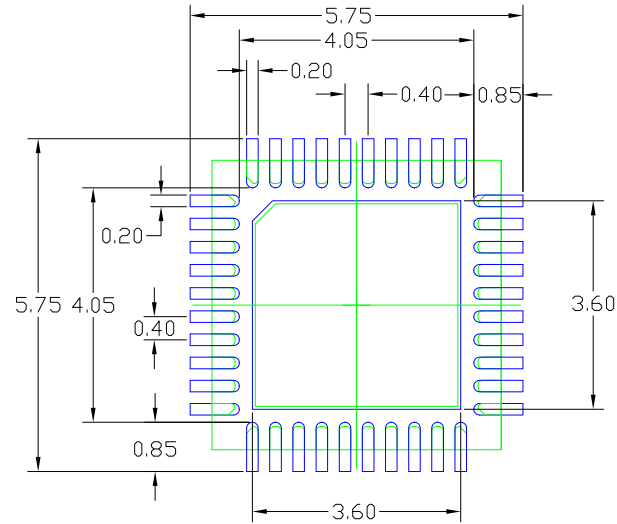

RECOMMENDED LAND PATTERN

NOTES:

1. ALL DIMENSIONS ARE IN mm. ANGLES IN DEGREES.
2. TOP DOWN VIEW AS VIEWED ON PCB.
3. COMPONENT OUTLINE SHOWS FOR REFERENCE IN GREEN.
4. LAND PATTERN IN BLUE. NSMD PATTERN ASSUMED.
5. LAND PATTERN RECOMMENDATION PER IPC-7351B GENERIC REQUIREMENT FOR SURFACE MOUNT DESIGN AND LAND PATTERN.

TOLERANCES UNLESS SPECIFIED		 www.IDT.com		6024 SILVER CREEK VALLEY ROAD, SAN JOSE, CA 95138	
DECIMAL	ANGULAR			PHONE: (408) 284-8200	
X±.1	±1°	FAX: (408) 284-3572			
XX±.05		APPROVALS			
XXX±.030		DATE	TITLE		
		DRAWN <i>mar</i>	5.0 x 5.0 mm BODY, EPAD 3.50mm SQ.		
		CHECKED	0.40 mm PITCH QFN		
			SIZE	DRAWING No.	REV
			C	PSC-4292-02	00
DO NOT SCALE DRAWING					SHEET 2 OF 2