

REVISIONS			
DATE	REV	DESCRIPTION	AUTHOR
11/14/08	00	INITIAL RELEASE	RC
11/28/12	01	ADD EPAD OPTION	RC
12/5/13	02	COMBINE POD & LAND PATTERN	J.HUA
7/14/14	03	Change Dimension aaa	J.HUA
3/1/19	04	Add Wettable Flank Option	J.HUA
9/19/19	05	Add Wettable Flank S2	J.HUA

NOTE: REFER TO DCP FOR OFFICIAL RELEASE DATE

EPAD OPTION

Symbol	P1			P2		
	MIN	NOM	MAX	MIN	NOM	MAX
E2	0.95	1.10	1.25	1.55	1.65	1.75
D2	0.95	1.10	1.25	1.55	1.65	1.75

Symbol	S1 (FUSED LEAD)			S2		
	MIN	NOM	MAX	MIN	NOM	MAX
E2	1.55	1.65	1.75	1.55	1.65	1.75
D2	1.55	1.65	1.75	1.55	1.65	1.75
R	0.075	---	0.175	0.075	---	0.175
S	0.001	---	0.09	0.001	---	0.09

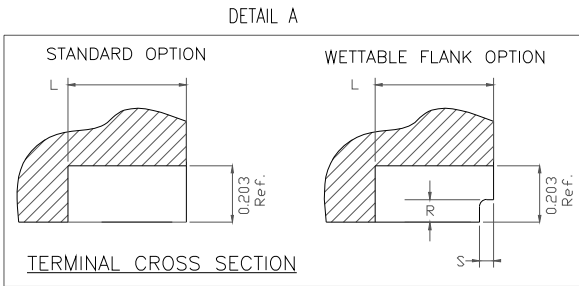

COMMON DIMENSION

Symbol	DIMENSION		
	Min	Nom	Max
A	0.80	0.90	1.00
A1	0	0.02	0.05
A3	0.20 Ref		
b	0.17	0.20	0.25
e	0.40 BASIC		
N	20		
ND	5		
NE	5		
D	3.00 BASIC		
E	3.00 BASIC		
D2	SEE EPAD OPTION		
E2	SEE EPAD OPTION		
L	0.30	0.40	0.50

NOTE :

1. ALL DIMENSIONS ARE IN mm. ANGLES IN DEGREES.
2. COPLANARITY APPLIES TO THE EXPOSED PAD AS WELL AS THE TERMINALS. COPLANARITY SHALL NOT EXCEED 0.05 mm.
3. WARPAGE SHALL NOT EXCEED 0.05 mm.
4. PACKAGE LENGTH / PACKAGE WIDTH ARE CONSIDERED AS SPECIAL CHARACTERISTIC. (S)
5. REFER JEDEC MO-220.

TOLERANCES UNLESS SPECIFIED DECIMAL ANGULAR X± ±1° XX± XXX±	 www.IDT.com	6024 Silver Creek Valley Road San Jose CA 95138 PHONE: (408) 284-8200 FAX: (408) 284-8591	
		TITLE NDC20 Package Outline Drawing 3.0 x 3.0 mm Body 0.40mm Pitch VFQFPN	
SIZE	DRAWING No.	REV	
C	PSC-4179	05	
DO NOT SCALE DRAWING		SHEET 1 OF 2	

REVISIONS			
DATE	REV	DESCRIPTION	AUTHOR
11/14/08	00	INITIAL RELEASE	RC
11/28/12	01	ADD EPAD OPTION	RC
12/5/13	02	COMBINE POD & LAND PATTERN	J.HUA
7/14/14	03	Change Dimension aaa	J.HUA
3/1/19	04	Add Wettable Flank Option	J.HUA
9/19/19	05	Add Wettable Flank S2	J.HUA

NOTE: REFER TO DCP FOR OFFICIAL RELEASE DATE

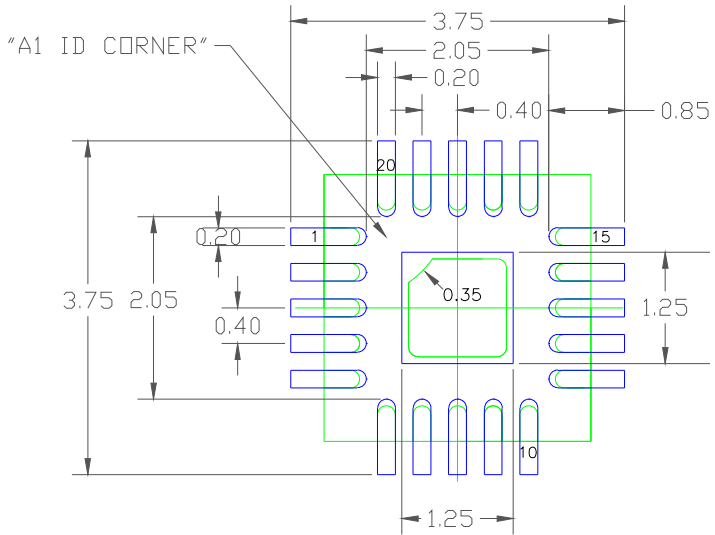

P1
EPAD 1.1 mm SQ

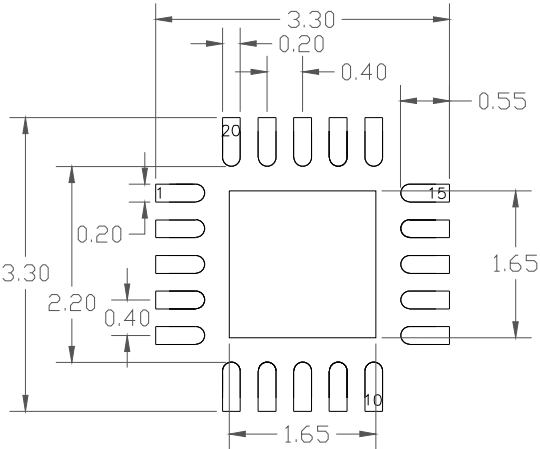

P2 & S1
EPAD 1.65 mm SQ

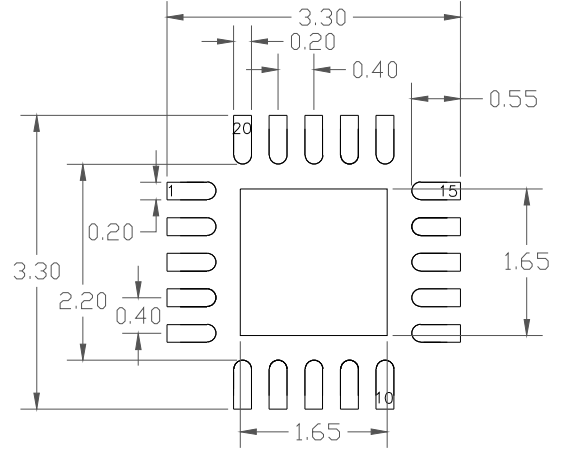

S2
EPAD 1.65 mm SQ

RECOMMENDED LAND PATTERN DIMENSION

NOTES:

1. ALL DIMENSION ARE IN MM. ANGLES IN DEGREES.
2. TOP DOWN VIEW. AS VIEWED ON PCB.
3. COMPONENT OUTLINE SHOW FOR REFERENCE IN GREEN.
4. LAND PATTERN IN BLUE. NSMD PATTERN ASSUMED.
5. LAND PATTERN RECOMMENDATION PER IPC-7351B GENERIC REQUIREMENT FOR SURFACE MOUNT DESIGN AND LAND PATTERN.

TOLERANCES UNLESS SPECIFIED DECIMAL ANGULAR X± ±1° XX± XXX±		6024 Silver Creek Valley Road San Jose CA 95138 PHONE: (408) 284-8200 FAX: (408) 284-8591	
		www.IDT.com	
TITLE NDG20 Package Outline Drawing 3.0 x 3.0 mm Body 0.40mm Pitch VFQFPN			
SIZE C	DRAWING No. PSC-4179	REV 05	
DO NOT SCALE DRAWING			SHEET 2 OF 2