

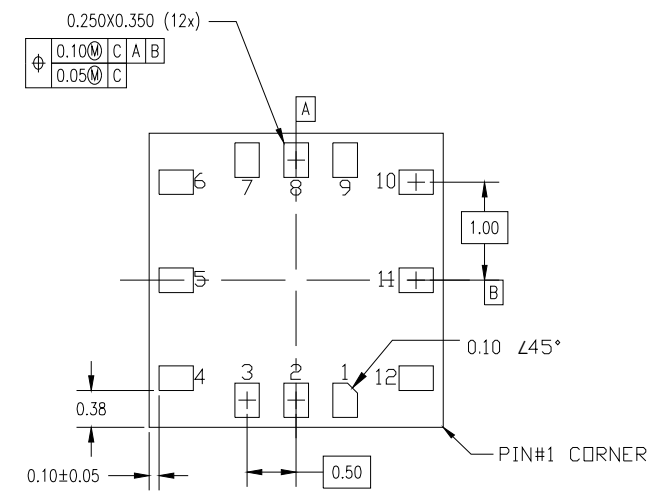

DATE		REVISIONS	
CREATED	REV	DESCRIPTION	AUTHOR
3/6/17	00	INITIAL RELEASE	JH
9/12/19	01	Add Dimeter Dimension on Gal Inlet Hole	JH
12/17/19	02	Add Dimension location on Gal Inlet	JH

NOTE: REFER TO DCP FOR OFFICIAL RELEASE DATE

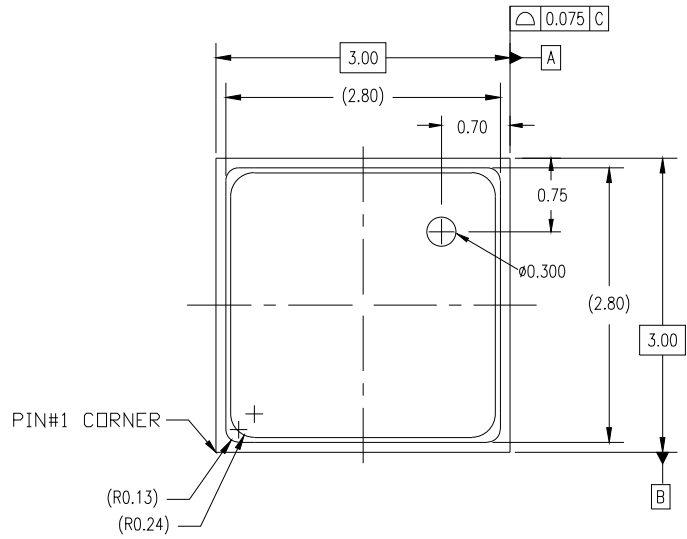

- NOTES:
1. ALL DIMENSIONING AND TOLERANCING CONFORM TO ANSI Y14.5M-1982
 2. ALL DIMENSION ARE IN MILLIMETERS.

TOLERANCES UNLESS SPECIFIED		 6024 Silver Creek Valley Road San Jose, CA 95138 PHONE: (408) 284-8200 FAX: (408) 284-8591	
DECIMAL	ANGULAR	www.IDT.com	
XX±	±	TITLE LGG12 PACKAGE OUTLINE 3.0 x 3.0 mm BODY, LGA	
XXX±		SIZE C	REV 02
XXXX±		DRAWING No. PSC-4685	
DO NOT SCALE DRAWING		SHEET 1 OF 2	

DATE	REVISIONS		
CREATED	REV	DESCRIPTION	AUTHOR
3/6/17	00	INITIAL RELEASE	JH
9/12/19	01	Add Dimeter Dimension on Gal Inlet Hole	JH
12/17/19	02	Add Dimension location on Gal Inlet	JH

NOTE: REFER TO DCP FOR OFFICIAL RELEASE DATE

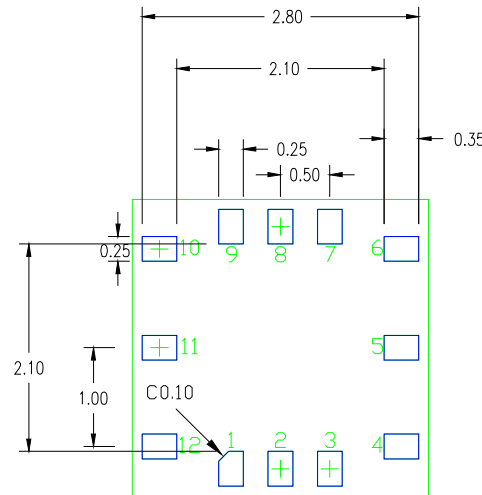

RECOMMENDED LAND PATTERN DIMENSION

NOTES:

1. ALL DIMENSION ARE IN MM. ANGLES IN DEGREES.
2. TOP DOWN VIEW. AS VIEWED ON PCB.
3. COMPONENT OUTLINE SHOW FOR REFERENCE IN GREEN.
4. LAND PATTERN IN BLUE. NSMD PATTERN ASSUMED.
5. LAND PATTERN RECOMMENDATION PER IPC-7351B GENERIC REQUIREMENT FOR SURFACE MOUNT DESIGN AND LAND PATTERN.

TOLERANCES UNLESS SPECIFIED		 6024 Silver Creek Valley Road San Jose, CA 95138 PHONE: (408) 284-8200 FAX: (408) 284-8591	
DECIMAL	ANGULAR	www.IDT.com	
XX±	±	TITLE LGG12 PACKAGE OUTLINE 3.0 x 3.0 mm BODY, LGA	
XXX±		SIZE	REV
XXXX±		C	02
		DRAWING No. PSC-4685	
		DO NOT SCALE DRAWING	
		SHEET 2 OF 2	