

REVISIONS				
DCN	REV	DESCRIPTION	DATE	APPROVED
61511	00	INITIAL RELEASE	09/20/98	

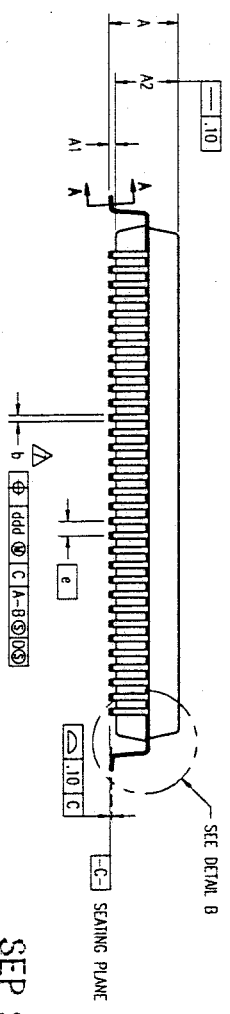
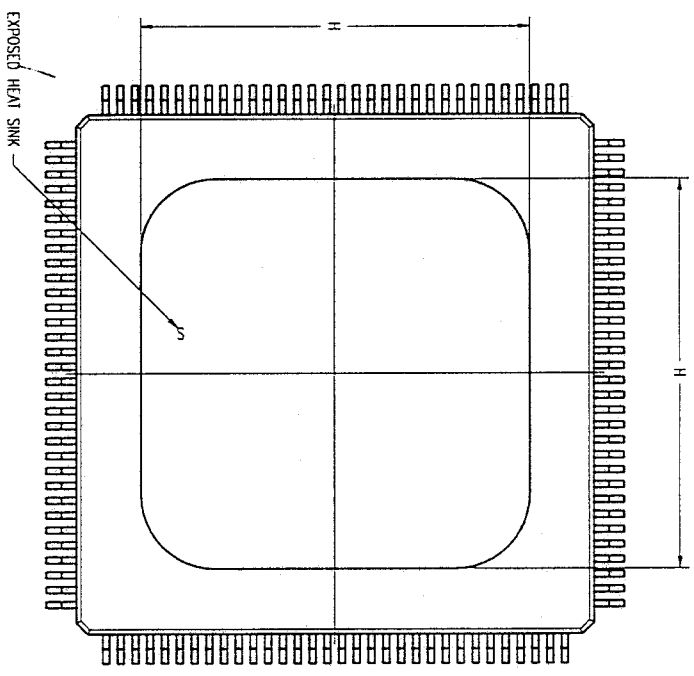
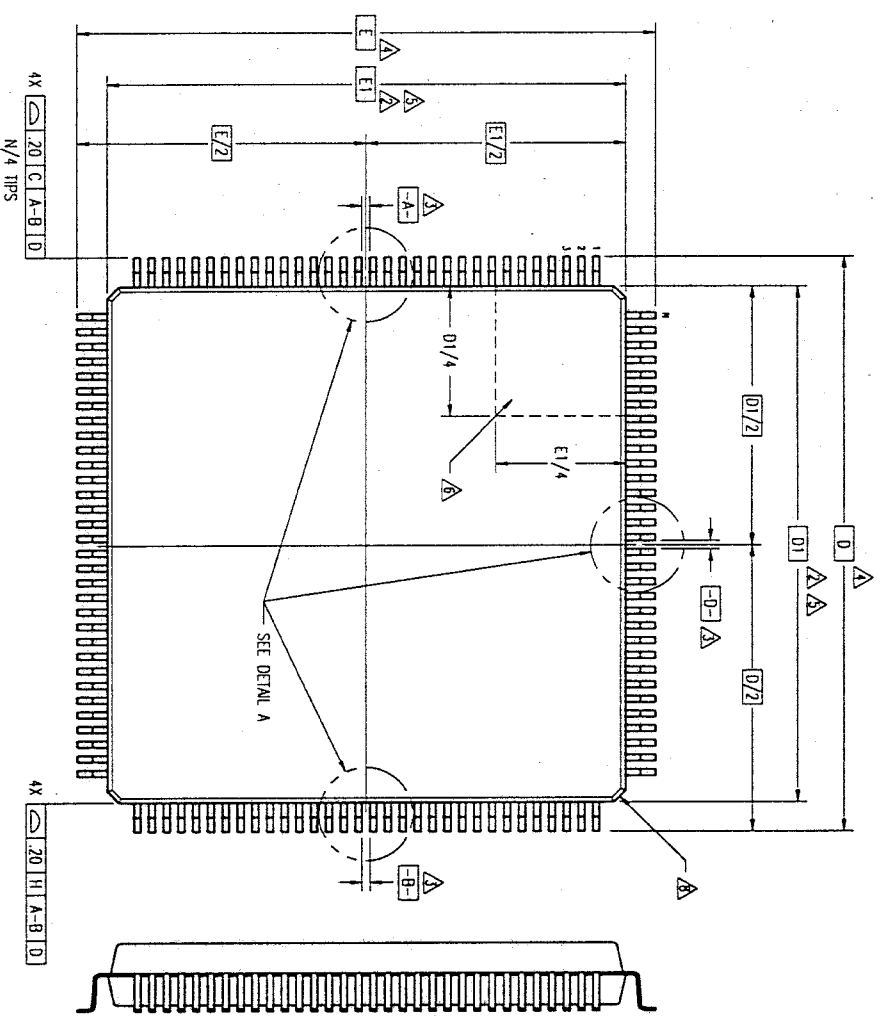

SEP 30 1998

TOLERANCES UNLESS SPECIFIED			Integrated Device Technology, Inc. 2975 Stoner Way, Santa Clara, CA 95054 PHONE: (408) 777-0118 FAX: (408) 492-8874 TWX: 910-338-2070	
DECIMAL	ANGULAR		APPROVALS DRAWN: 37U DATE: 10/20/98 CHECKED:	TITLE DZ PACKAGE OUTLINE 28.0 X 28.0 X 3.4 mm PQFP 1.60/25 MIN FORM
SIZE	DRAWING NO.	REV		
C	PSC-4070	00		
DO NOT SCALE DRAWING			SHEET 1 OF 3	

REVISIONS				
DCN	REV	DESCRIPTION	DATE	APPROVED
61511	00	INITIAL RELEASE	09/20/98	

EVEN LEAD SIDES ODD LEAD SIDES

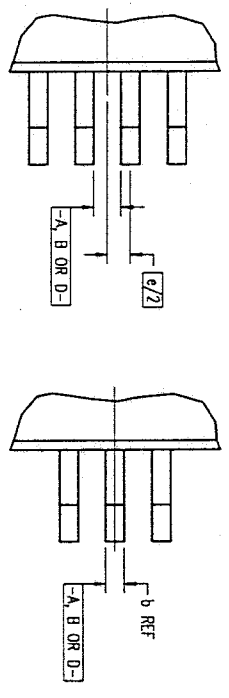

DETAIL A

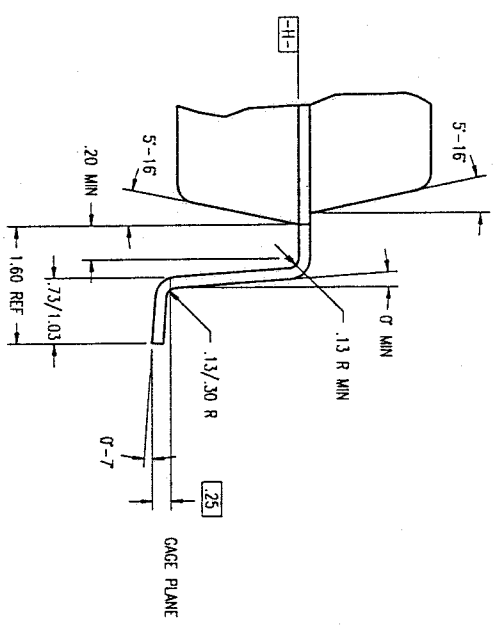

DETAIL B

SEP 30 1998

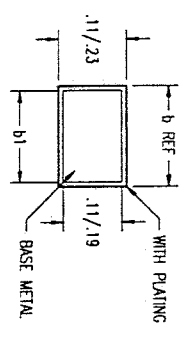

SECTION A-A

TOLERANCES UNLESS SPECIFIED			Integrated Device Technology, Inc. 2875 Steiner Way, Santa Clara, CA 95054 Phone: (408) 727-6116 Fax: (408) 482-6674 TWX: 910-338-2070
DECIMAL	ANGULAR		
±	±		
APPROVALS	DATE	TITLE	REV
XXXXX	09/20/98	DZ PACKAGE OUTLINE	00
DRAWN 372		28.0 X 28.0 X 3.4 mm PQFP	
CHECKED		1.60/.25 MIN FORM	
		DRAWING No. PSC-4070	
		DO NOT SCALE DRAWING	
			SHEET 2 OF 3

REVISIONS			
DCN	REV	DESCRIPTION	DATE
61511	00	INITIAL RELEASE	09/20/98
			APPROVED

LAND PATTERN DIMENSIONS

S	JEDEC VARIATION			N	D	T	E
	DC-1						
M	MIN	NOM	MAX				
A	-	-	4.10				
A1	.25	-	-				
A2	3.20	3.40	3.60				
D	31.20 BSC				4		
D1	28.00 BSC				5.2		
E	31.20 BSC				4		
E1	28.00 BSC				5.2		
H	21.00 REF						
N	128						
e	.80 BSC						
b	.29	-	.45		7		
b1	.29	.35	.41				
ddd	-	-	.20				

NOTES:

- 1 ALL DIMENSIONING AND TOLERANCING CONFORM TO ASME Y14.5M-1994
- TOP PACKAGE MAY BE SMALLER THAN BOTTOM PACKAGE BY .15 mm
- DATUMS [A-B] AND [D-E] TO BE DETERMINED AT DATUM PLANE [H]-[I]
- DIMENSIONS D AND E ARE TO BE DETERMINED AT SEATING PLANE [C]-[D]
- DIMENSIONS D1 AND E1 DO NOT INCLUDE MOLD PROTRUSION. ALLOWABLE MOLD PROTRUSION IS .25 mm PER SIDE. D1 AND E1 ARE BODY SIZE DIMENSIONS INCLUDING MOLD MISMATCH
- DETAIL OF PIN 1 IDENTIFIER IS OPTIONAL BUT MUST BE LOCATED WITHIN THE ZONE INDICATED
- DIMENSION b DOES NOT INCLUDE DAMBAR PROTRUSION. ALLOWABLE DAMBAR PROTRUSION IS .08 mm IN EXCESS OF THE b DIMENSION AT MAXIMUM MATERIAL CONDITION. DAMBAR CANNOT BE LOCATED ON THE LOWER RADIUS OR THE FOOT.
- EXACT SHAPE OF EACH CORNER IS OPTIONAL
- THESE DIMENSIONS APPLY TO THE FLAT SECTION OF THE LEAD BETWEEN .10 AND .25 mm FROM THE LEAD TIP
- ALL DIMENSIONS ARE IN MILLIMETERS
- THIS OUTLINE CONFORMS TO JEDEC PUBLICATION 95 REGISTRATION MS-022, VARIATION DB-1

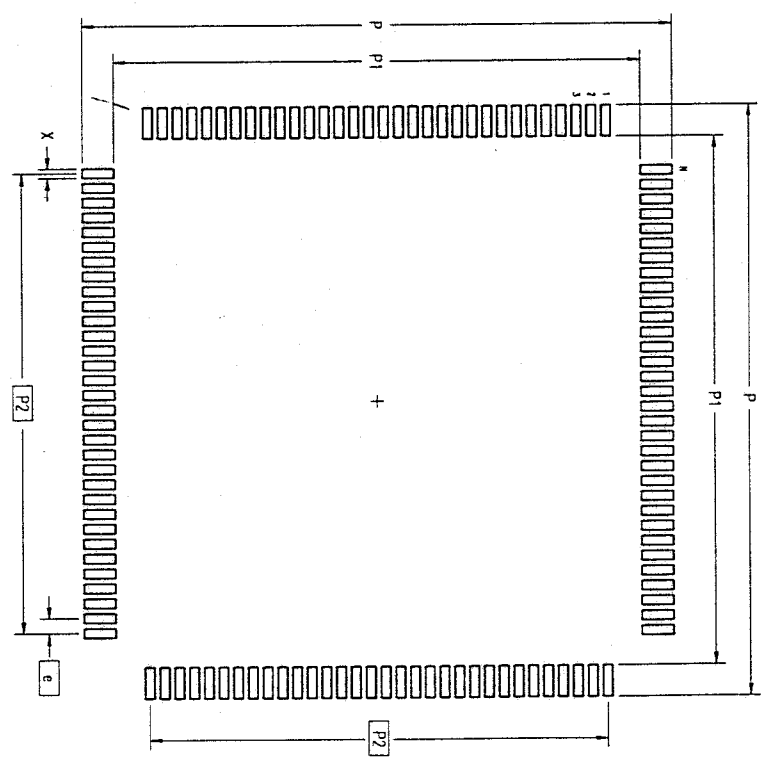

	MIN	MAX
P	31.80	32.00
P1	28.40	28.60
P2	24.80 BSC	
X	.40	.60
e	.80 BSC	
N	128	

SEP 3 0 1998

TOLERANCES UNLESS SPECIFIED

DECIMAL	±
ANGULAR	±

Integrated Device Technology, Inc.
 2875 Stonder Way, Santa Clara, CA 95054
 PHONE: (408) 727-6116 FAX: (408) 482-8674 TWX: 810-338-2070

DRAWN: 97 DATE: 09/20/98
 CHECKED: C SIZE: C
 TITLE: DZ PACKAGE OUTLINE
 28.0 X 28.0 X 3.4 mm PQFP
 1.60/.25 MIN FORM
 PSC-4070
 SHEET 3 OF 3