

REVISIONS			
REV	DESCRIPTION	DATE	APPROVED
00	INITIAL RELEASE	08/25/96	T.V
01	ACTIVE/INACTIVE	8/29/03	T.V
02	REMOVE FROM ASSEMBLY / CORRECT DIMENSIONS FROM .015 TO .15	10/02/03	T.V
02	COMBINE POD & LAND PATTERN	06/06/13	KS

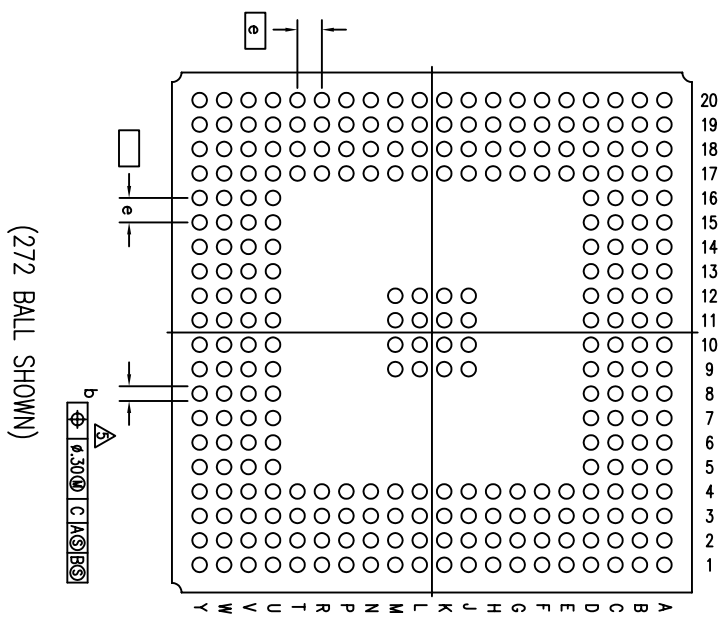

(272 BALL SHOWN)

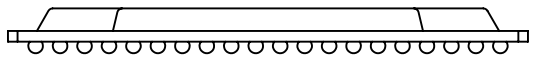
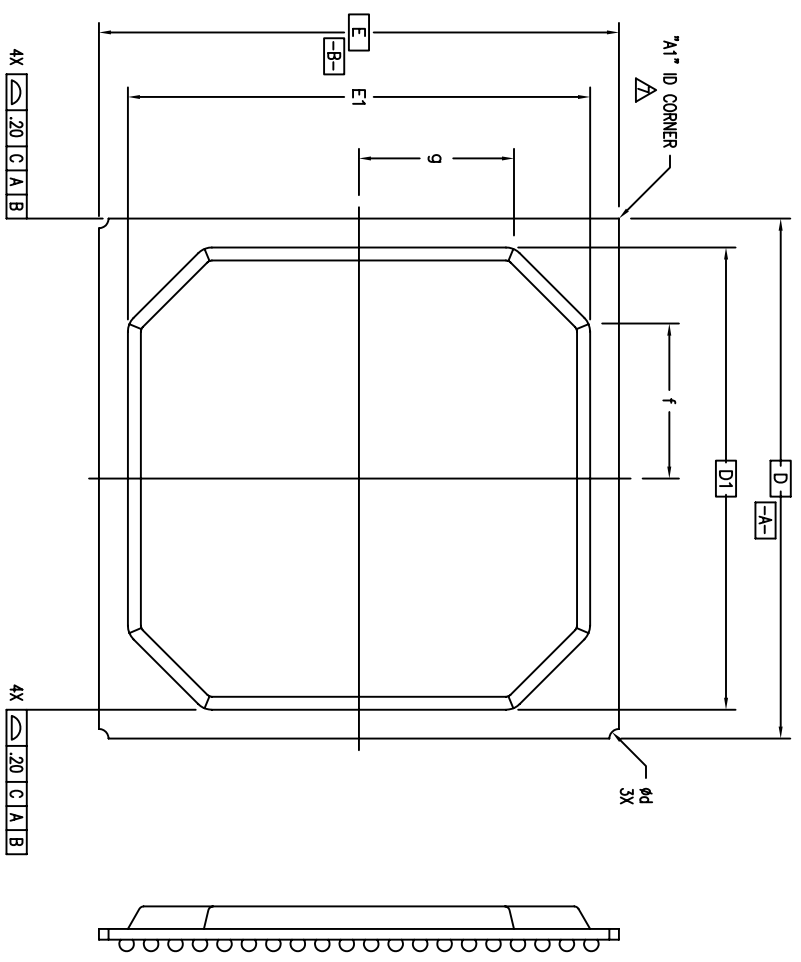
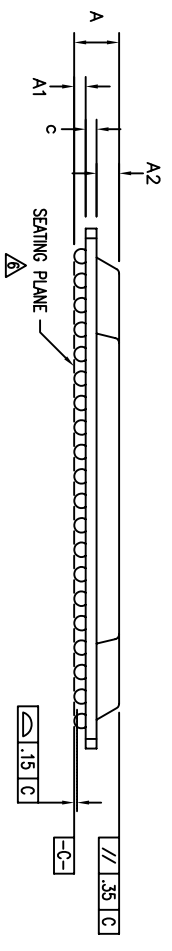

<b>TOLERANCES UNLESS SPECIFIED</b> DECIMAL .0005 ANGULAR ± .001 XXX± .001 XXXX± .001		<b>IDT</b> 6024 SILVER CREEK VALLEY ROAD San Jose, CA 95138 PHONE: (408) 284-8200 FAX: (408) 284-8591	
<b>APPROVALS</b> DRAWN: JTY CHECKED:	<b>DATE</b> 08/25/96	<b>TITLE</b> BG PACKAGE OUTLINE 27.0 X 27.0 mm BODY PBGA	<b>SIZE</b> C <b>DRAWING No.</b> PSC-4058
DO NOT SCALE DRAWING		SHEET 1 OF 3	

REVISIONS			
REV	DESCRIPTION	DATE	APPROVED
00	INITIAL RELEASE	08/25/96	T.V
OBS	ACTIVE/INACTIVE	8/29/03	T.V
01	REMOVE FROM OBSOLETE/ CORRECT TOLERANCES FROM .015 TO .15	10/02/03	T.V
02	COMBINE POD & LAND PATTERN	06/06/13	KS

NOTES:

- 1 ALL DIMENSIONING AND TOLERANCING CONFORM TO ANSI Y14.5M-1982
- 2 "e" REPRESENTS THE BASIC SOLDER BALL GRID PITCH
- 3 "M" REPRESENTS THE MAXIMUM SOLDER BALL MATRIX SIZE
- 4 "N" REPRESENTS THE BALLCOUNT NUMBER
- 5 DIMENSION "b" IS MEASURED AT THE MAXIMUM SOLDER BALL DIAMETER, PARALLEL TO PRIMARY DATUM  $\boxed{-C-}$
- 6 SEATING PLANE AND PRIMARY DATUM  $\boxed{-C-}$  ARE DEFINED BY THE SPHERICAL CROWNS OF THE SOLDER BALLS
- 7 "A1" ID CORNER MUST BE IDENTIFIED BY CHAMFER, INK MARK, METALLIZED MARKING, INDENTATION OR OTHER FEATURE ON PACKAGE BODY
- 8 ALL DIMENSIONS ARE IN MILLIMETERS
- 9 THIS DRAWING CONFORMS TO JEDEC PUBLICATION 95 REGISTRATION MO-151, VARIATION BAL

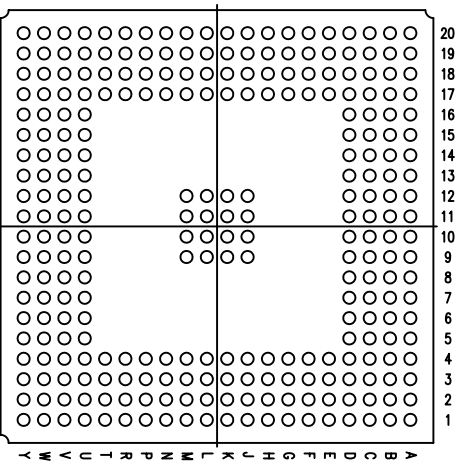
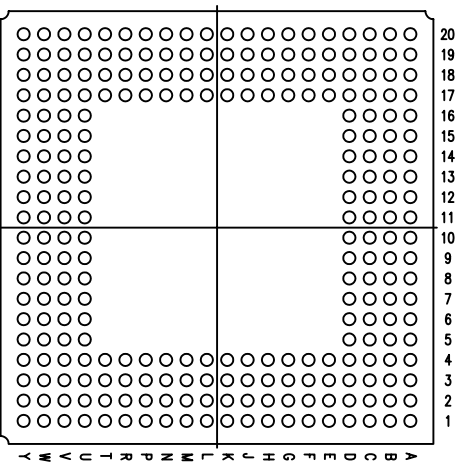

SYMBOL	JEDEC VARIATION			NOTE	JEDEC VARIATION			NOTE
	MIN	NOM	MAX		MIN	NOM	MAX	
A	1.92	-	2.54		1.92	-	2.54	
A1	.50	.60	.70		.50	.60	.70	
A2	1.12	1.17	1.22		1.12	1.17	1.22	
D		27.00 BSC				27.00 BSC		
D1		24.00 BSC				24.00 BSC		
E		27.00 BSC				27.00 BSC		
E1		24.00 BSC				24.00 BSC		
M		20 (DEPOPULATED)		3		20 (DEPOPULATED)		3
N		256		4		272		4
e		1.27 BSC				1.27 BSC		
b	.60	.76	.90	5	.60	.76	.90	5
c	.32	-	.60		.32	-	.60	
d		1.00 REF				1.00 REF		
f		8.05 REF				8.05 REF		
g		8.05 REF				8.05 REF		
CENTER BALL MATRIX		N/A				4 ROWS X 4 COLUMNS		

TOLERANCES UNLESS SPECIFIED		IDT 6024 SILVER CREEK VALLEY ROAD San Jose, CA 95138 PHONE: (408) 284-8200 FAX: (408) 284-8591 www.IDT.com	
DECIMAL	ANGULAR	TITLE BG PACKAGE OUTLINE 27.0 X 27.0 mm BODY PBGA	
XXX±	±		
APPROVALS	DATE	SIZE	DRAWING NO.
DRAWN 579	08/29/96	C	PSC-4058
CHECKED			REV 02
		DO NOT SCALE DRAWING	SHEET 2 OF 3

REVISIONS			
REV	DESCRIPTION	DATE	APPROVED
00	INITIAL RELEASE	08/25/96	T.V
00S	ACTIVE/INACTIVE	8/29/03	T.V
01	REMOVE FROM OBSOLETE/ REMOVE DIMENSIONS FROM .015 TO .15	10/02/03	T.V
02	COMBINE POD & LAND PATTERN	06/06/13	KS

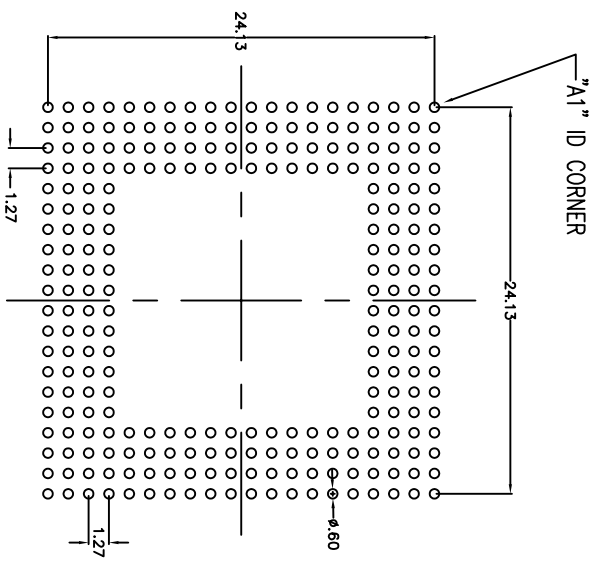

(256 BALL)

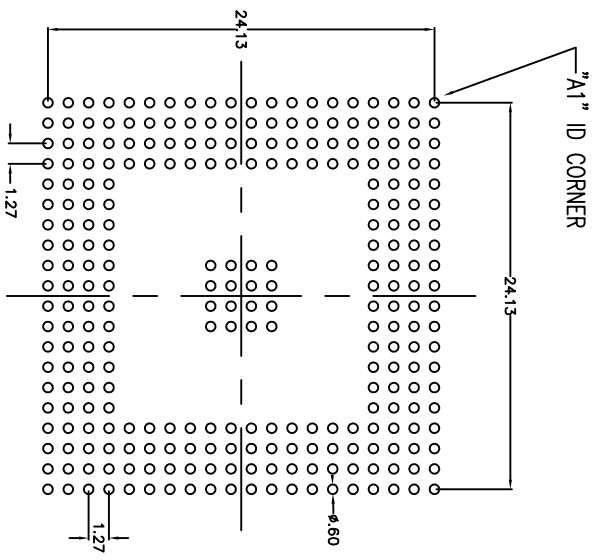

(272 BALL)

RECOMMENDED LAND PATTERN DIMENSION

NOTE:

- 1) ALL dimensions are in mm, Angles in degrees.
- 2) Top down view, as view on PCB.
- 3) NSMD Land Pattern Assumed
- 4) Land Pattern Recommendation as per IPC-7351B generic requirement for surface mount design and Land Pattern.

TOLERANCES UNLESS SPECIFIED		IDT 6024 SILVER CREEK VALLEY ROAD SAN JOSE, CA 95138 PHONE: (408) 264-6200 FAX: (408) 264-8591	
DECIMAL	ANGULAR	www.IDT.com	
XX±	±	PBCA	
XXXX±		TITLE BG PACKAGE OUTLINE	
APPROVALS	DATE	27.0 X 27.0 mm BODY	
DRAWN 97Y	08/25/96	PBCA	
CHECKED		SIZE DRAWING No. PSC-4058	
		REV 02	
DO NOT SCALE DRAWING		SHEET 3 OF 3	