



# Tsi578/Freescale MSC8144 AMC

## RapidIO Switch

- Switches data from each of the four MSC8144 DSPs to the AMC connector
  - Tsi578-to-MSC8144 links are 4x Serial RapidIO connections
- Four 4x mode Serial RapidIO interfaces to the AMC connector
- Industry's lowest power per 10-Gbps port switch
- 80 Gbps of non-blocking bandwidth
- Low latency with cut-through capability
- High performance hardware multicast
- Receive equalization and transmit pre-emphasis for high signal integrity
- Programmable per port buffer management to ensure dedicated bandwidth for high priority packets
- Traffic shaping per port using first-come, first-serve, SP1 and SP2 scheduling algorithms
- Performance monitoring on individual ports
- Supports packet routing tables for 64,000 endpoints
- *RapidIO Interconnect Specification (Revision 1.3)* compliant

## MSC8144 DSP

- Four SC3400 Starcore DSP cores at 800 MHz /1 GHz
- 16 ALUs delivering up to 12800/16000 MMACS
- 512 KB shared M2 memory
- 10 MB of shared M3 memory
- DDR memory controller
  - 400 MHz, 16 or 32-bit
- Eight TDM interfaces, total of 2048 DS-0 channels
- Security Engine Core (SEC) optimized for IPSec, IKE, WTLS/WAP, SSL/TLS, and 3GPP protocols
- One Serial RapidIO interface supporting 4x and 1x modes
- Dual RISC QUICCEngine at 400 MHz
- Dual Gigabit Ethernet interfaces supporting RGMII and SGMII
- ATM protocols controller supporting a UTOPIA interface
- POS-PHY support
- Serial Peripheral Interface, I2C, and UART

IDT partners the technology of Freescale Semiconductor, one of the world's leading semiconductor companies, with IDT's industry-proven Tsi578 16/8 RapidIO switch to create an AMC form-factor development platform. The AMC combines the industry's highest performing programmable DSPs and the lowest power Serial RapidIO switch available.

## Tsi578 and Freescale AMC



The AMC leverages Serial RapidIO interconnect technology, using IDT's Tsi578 switch to cluster four Freescale MSC8144 multi-core DSPs in an AMC single-width form factor enabling the development of AdvancedTCA and MicroTCA-based systems.

## AMC Block Diagram

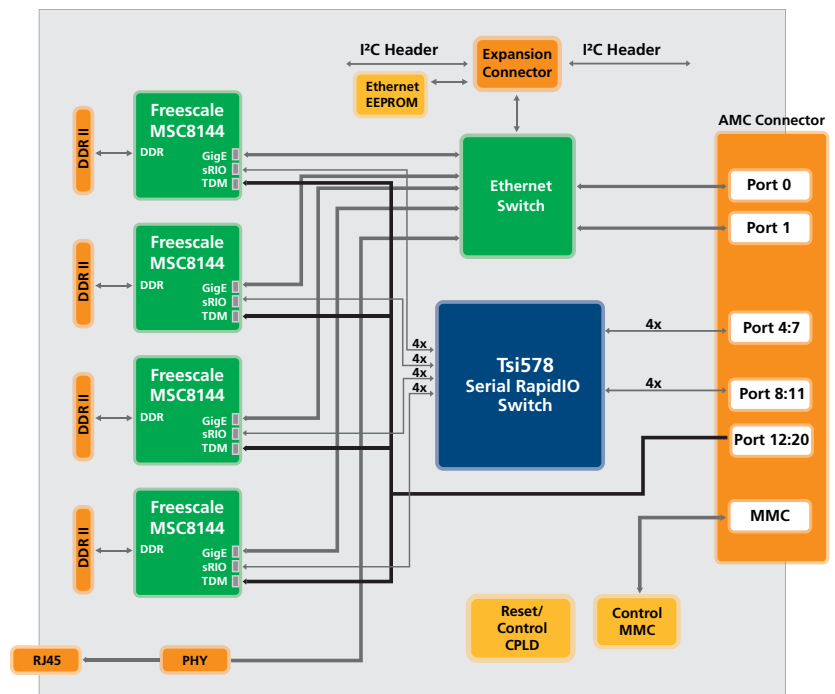

## AMC Features

### I/O Features

- Standards-based AMC Connector
- Two Gigabit Ethernet interfaces
- Two 1x/4x Serial RapidIO Ports
- TDM (16Tx, 16Rx, SYNC, CLK)

### Front Panel Expansion and Debug Features

- One Gigabit Ethernet interface (RJ45)
- One JTAG interface
- One UART interface
- SPI/I2C Programming Headers

### Electrical Characteristics

- Differential AC-coupled 156.25 MHz reference clock for the serial transmit and internal switching fabric domains
- Powered through an AMC connector from in a chassis or three-pin on-board power connector for a bench power supply
- PICMG AMC.0 R2 standard, single width, full height module
- 12 V DC power supply from AMC connector.
- Power requirements:
  - 3.3 V for I/O
  - 1.0 V for the MSC8144 Core
  - 1.2 V for MSC8144 M3 memory and the Tsi578 Core
  - 1.2 V, 1.5 V, and 2.5 V for Ethernet

## AMC Benefits

- Tsi578-to-MSC8144 4x Serial RapidIO connections ensure high bandwidth data transfer in applications such as WiMAX, 3G LTE, and Video Conferencing
- Optimal routing of AMC with four DSPs
- Off-loads DSP termination overhead for the data plane using Serial RapidIO
- High-bandwidth Serial RapidIO data plane
- Gigabit Ethernet implemented for the control plane
- Redundant 4x Serial RapidIO interfaces to the AMC connector for high reliability applications
- Rapid development and prototyping of application software

## Applications

Freescale and IDT created the AMC to address interconnect bandwidth requirements of up to 10 Gbps between on-board components in the following key applications:

- 3.5G and 4G Wireless base stations
- Radio network controllers
- Media gateways
- Video conferencing
- Radar signal processing
- High-density video conference MCU

These processing-intensive applications require high performance DSPs and the high throughput, low latency characteristics of a RapidIO solution.

## Interoperability

IDT and Freescale have proven RapidIO connectivity between the IDT Tsi578 and the Freescale MSC8144 across physical, logical, and transport layers. Additionally, IDT's Tsi578 has successfully passed interoperability testing (Level 3 certification) by RIOLAB, the world's only independent Serial RapidIO testing facility. Visit [www.rio-lab.com](http://www.rio-lab.com) for more information.

## Device and Board Information

### About the Tsi578/Freescale MSC8144

The Tsi578 is IDT's third-generation RapidIO switch. Supporting 80 Gbps aggregate bandwidth, the Tsi578 enables customers to develop high-performance RapidIO systems at low cost.

The Tsi578 flexible port configurations can be selected through multiple port width and speed options. The device can be configured as a 16-port 1x mode switch or an 8-port 4x mode switch (or various combinations of 1x mode and 4x mode). Each port can operate at 1.25, 2.5, or 3.125 Gbaud.

### About the Freescale MSC8144

The MSC8144 takes single-chip DSP integration to a new level of sophistication, combining four StarCore® DSP cores at up to 1 GHz each, delivering the industry's highest performance, equivalent to a 4 GHz single-core DSP. The device integrates the industry's largest embedded memory at 10.9 MB, enabling higher throughput to memories than external DDR while reducing chip count and BOM. The part leverages dual RISC QUICCEngine technology at 400 MHz to offload networking protocols, and it offers high-speed interfaces such as the 4x mode Serial RapidIO and dual SGMII Gigabit Ethernet interfaces.

DISCLAIMER Integrated Device Technology, Inc. (IDT) and its subsidiaries reserve the right to modify the products and/or specifications described herein at any time and at IDT's sole discretion. All information in this document, including descriptions of product features and performance, is subject to change without notice. Performance specifications and the operating parameters of the described products are determined in the independent state and are not guaranteed to perform the same way when installed in customer products. The information contained herein is provided without representation or warranty of any kind, whether express or implied, including, but not limited to, the suitability of IDT's products for any particular purpose, an implied warranty of merchantability, or non-infringement of the intellectual property rights of others. This document is presented only as a guide and does not convey any license under intellectual property rights of IDT or any third parties.

IDT's products are not intended for use in life support systems or similar devices where the failure or malfunction of an IDT product can be reasonably expected to significantly affect the health or safety of users. Anyone using and IDT product in such a manner does so at their own risk, absent an express, written agreement by IDT.

Integrated Device Technology, IDT and the IDT logo are registered trademarks of IDT. Other trademarks and service marks used herein, including protected names, logos and designs, are the property of IDT or their respective third party owners.



**CORPORATE HEADQUARTERS**  
6024 Silver Creek Valley Road  
San Jose, CA 95138

**for SALES:**  
800-345-7015 or 408-284-8200  
fax: 408-284-2775  
[www.idt.com](http://www.idt.com)

**for Tech Support:**  
408-360-1533  
[sRIO@idt.com](mailto:sRIO@idt.com)  
Document: 80B8030\_FB002\_02