



Integrated Device Technology

89HT0816AP Retimer Evaluation Board

89KTT0816AP kit for 8.0Gbps, 8-lane PCIe 3.0 applications

CLOCKS AND TIMING

INTERFACE AND CONNECTIVITY

MEMORY AND LOGIC

POWER MANAGEMENT

RF PRODUCTS

FEATURES

- Compensates for long PCB trace or cable attenuation and jitter
- 8-lane PCIe adapter card with full PCIe 3.0 protocol support
- Configurable via I²C using IDT Windows GUI tool. JTAG interface also provided
- EEPROM supports automatic download of configuration data to the 89HT0816AP Retimer
- Enables individual channel configurations of equalization and many operating parameters
- Enables use of the On-Die scope function with Windows GUI tool
- Switches allow control of power-on equalization preset hints
- Multiple power connection options
- Card format: 6.375" x 4.75", non-standard size. Use requires an open chassis
- Works with passive trace cards to extend FR4 traces, also available from IDT (6", 12", 24")

Benefits

- Quick, convenient evaluation of IDT's 89HT0816AP Retimer operation
- Extends trace length by improving voltage and timing margins
- Minimizes BER, improving system performance and reliability
- Can speed design time and reduce risk by eliminating signal integrity issues

Kit Contents

- 1- 89HT0816AP 8-lane, 8.0 Gbps PCIe 3.0 Retimer Evaluation Board
- 1- CD with Windows GUI software tools and design documentation
- 1- 89HT0816AP Evaluation Board User's Guide document
- Order number: 89KTT0816AP

System Requirements

- PC or Server with x 8 or x16-lane PCIe slot – with PCIe 3.0 support recommended (but optional)
- Desktop or notebook PC with Windows NT, Win7 or Vista to use IDT configuration GUI and ODS tools
- Target add-in cards for system tests

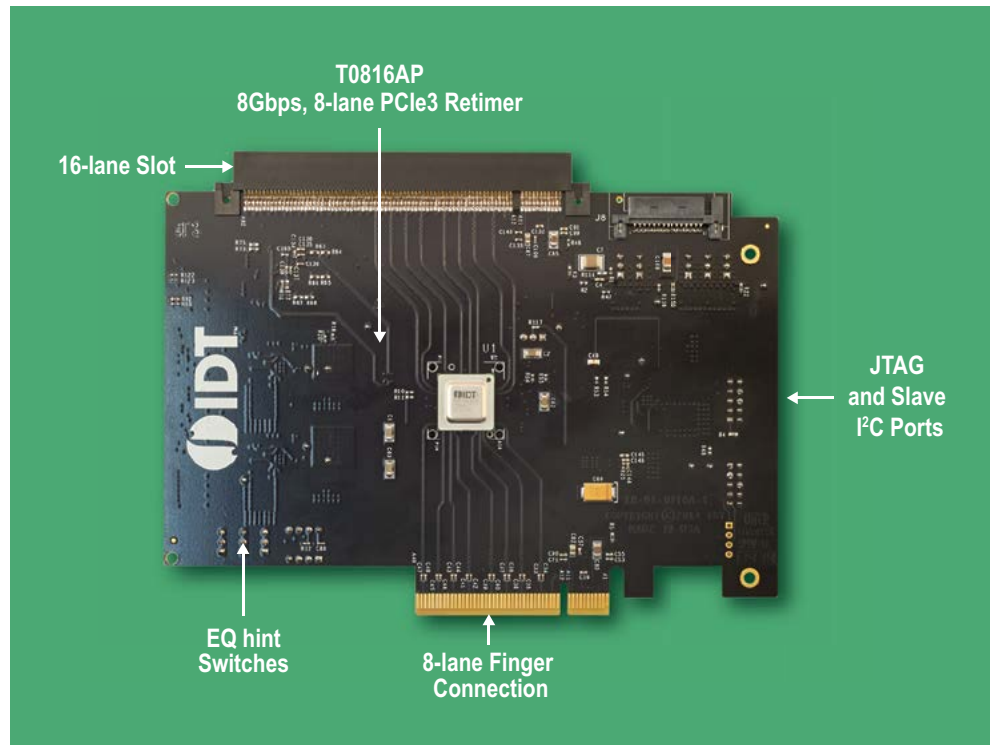

Device Overview

The 89HT0816AP Retimer Evaluation Board is designed to enable quick in-system testing of IDT's 8-lane, 8.0Gbps, PCIe 3.0 Retimer IC product.

The Board features an 8-lane connection from host through the retimer to an end-point device installed in the upper PCIe slot. Any width adapter card, from a 1-lane SATA card to a 16-lane graphics accelerator, can be plugged into the top-edge PCIe slot and will train to 8-lanes as active. An I²C port allows connection to a PC for accessing the retimer CSR registers using an external USB to I²C adapter together with IDT's Retimer GUI. Via the GUI, the device receiver, transmitter and many other configuration parameters can be adjusted to provide optimum operating performance.

The Evaluation Board is used by inserting it into a desktop PC or server and then plugging an end point card (SATA, Ethernet, USB3, etc.) into the 16-lane slot on top, as shown in the example diagram and photo on the following page. Passive trace cards can be used to extend the data signal to emulate a planned system design. Note that the resulting card stack will require an open chassis test environment. IDT's Technical Applications information can provide configuration for different channel lengths and system architectures.

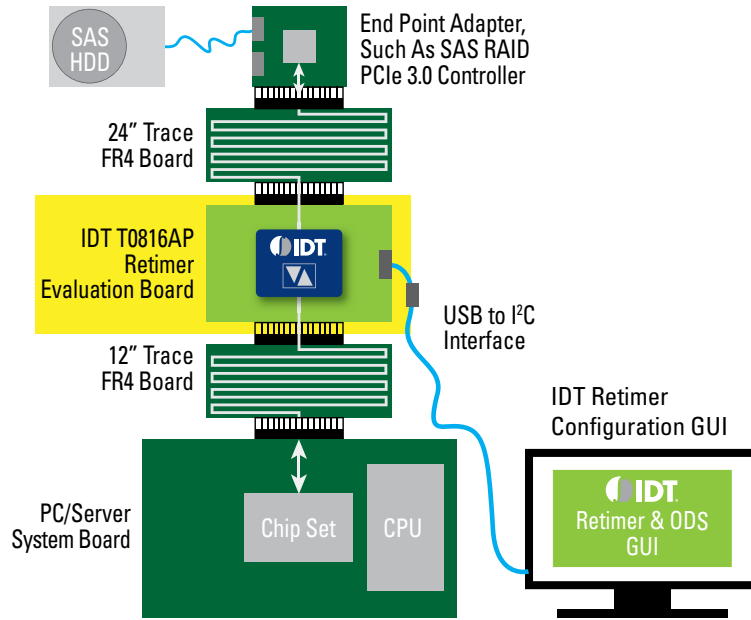

Example Use

This simple example shows the 89HT0816P Retimer Evaluation Board used to extend 8 Gbps signals across a 24-inch passive trace card to a SAS controller and to the host system across another 12-inch passive extender card.

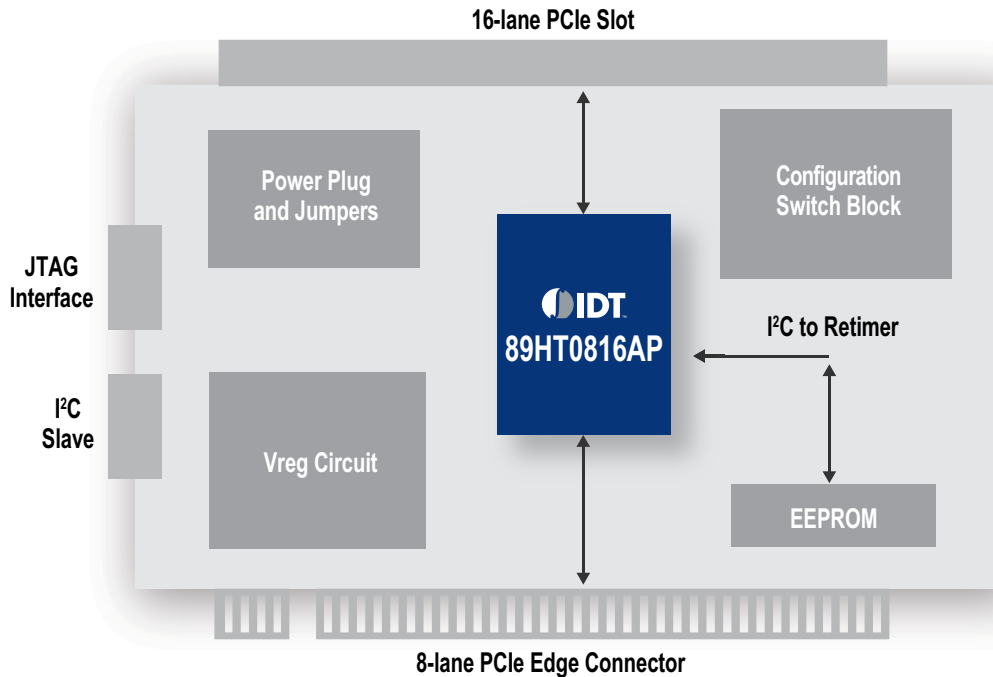

Block Diagram

A block diagram of the 89HT0816P Retimer Evaluation Board is shown above. The board design includes one 8-lane 89HT0816P Retimer supporting an 8-lane link.

Discover what IDT know-how can do for you: www.IDT.com/go/SIP

DISCLAIMER Integrated Device Technology, Inc. (IDT) and its subsidiaries reserve the right to modify the products and/or specifications described herein at any time and at IDT's sole discretion. All information in this document, including descriptions of product features and performance, is subject to change without notice. Performance specifications and the operating parameters of the described products are determined in the independent state and are not guaranteed to perform the same way when installed in customer products. The information contained herein is provided without representation or warranty of any kind, whether express or implied, including, but not limited to, the suitability of IDT's products for any particular purpose, an implied warranty of merchantability, or non-infringement of the intellectual property rights of others. This document is presented only as a guide and does not convey any license under intellectual property rights of IDT or any third parties. IDT's products are not intended for use in life support systems or similar devices where the failure or malfunction of an IDT product can be reasonably expected to significantly affect the health or safety of users. Anyone using an IDT product in such a manner does so at their own risk, absent an express, written agreement by IDT.

Integrated Device Technology, IDT and the IDT logo are registered trademarks of IDT. Other trademarks and service marks used herein, including protected names, logos and designs, are the property of IDT or their respective third party owners. © Copyright 2014. All rights reserved.