

RTKA-BDGSTKEV2Z

User's Manual: Evaluation Board

Industrial Analog and Power

All information contained in these materials, including products and product specifications, represents information on the product at the time of publication and is subject to change by Renesas Electronics Corp. without notice. Please review the latest information published by Renesas Electronics Corp. through various means, including the Renesas Electronics Corp. website (<http://www.renesas.com>).

RTKA-BDGSTKEV2Z

Evaluation Board

The DAQ on a Stick, Renesas Strain Gauge is one of a series of reference designs highlighting Renesas precision products. This reference design is a self contained demonstration showing a complete signal chain solution using Renesas precision parts and a Renesas microcontroller. The complete reference design is conveniently housed in a USB stick form factor. This compact design draws power through the USB port and uses a Graphical User Interface (GUI) to display the real time voltage readings from a bridge strain gauge or a user supplied sensor. [Figure 1](#) shows the Data Acquisition (DAQ) on a Stick connected to an external foil strain gauge.

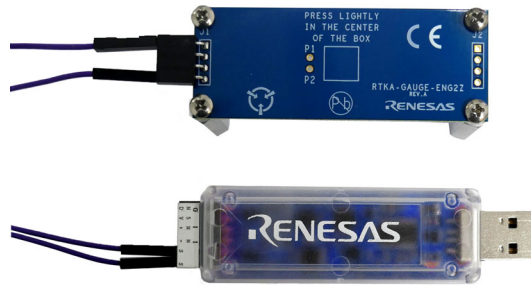

Figure 1. DAQ on a Stick with Strain Gauge

[Figure 2](#) shows a simplified schematic of the Strain Gauge design. The design uses the Renesas ISL28134 chopper amplifier, ISL22316 Digitally Controlled Potentiometer (DCP), ISL43840 dual 4-channel Mux configured as a Differential Mux, ISL21010 3.3V and 4.096V precision voltage references, ISL26102 24-bit delta sigma converter, and the R5F10JBC microcontroller.

Ordering Information

Part Number	Description
RTKA-BDGSTKEV2Z	Evaluation Board

Related Literature

For a full list of related documents, visit our website:

- [ISL28134](#), [ISL21010](#), [ISL26102](#), [ISL43840](#), [ISL22316](#), and [R5F10JBC](#) device pages

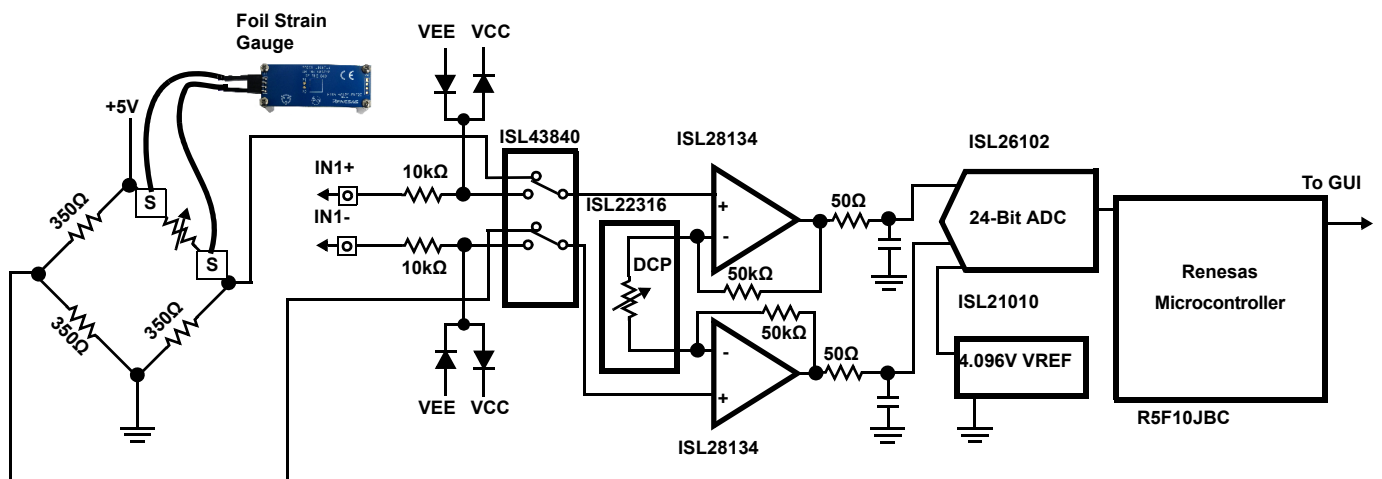

Figure 2. Simplified Strain Gauge Schematic

1. Getting Started

1.1 Installing the Software and USB Drivers

Download the software and a short video on the operation of this application from the Renesas [website](#).

The software and USB drivers must be installed on a PC running Windows NT/2000/XP/Vista/Win7/Win 8/Win 10 operating system before connecting the RTKA-BDGSTKEV2Z evaluation board to the USB port.

1.2 Loading the Software

1. Click the Renesas DAQ on a Stick Software link to load the executable.
2. Follow the on-screen instructions to complete the software installation. The installation program places the user interface software in the C:\Program Files\R12UZ0045_DAQ_V250 directory.
3. To create a shortcut on your desktop, check the **Create A Desktop Icon** box during the software installation.
4. Launch the application by checking the **Launch R12UZ0045_DAQ_V250** box, then click **Finish**.

1.3 Running the Evaluation Software

1. After installing the software, plug the RTKA-BDGSTKEV2Z board into a USB port on the computer and click the Renesas DAQ shortcut (created in "[Loading the Software](#)") on the desktop. [Figure 3](#) shows the desktop icon.

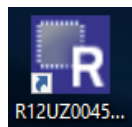

Figure 3. Desktop Icon

2. The green LED on the DAQ on a Stick board turns on. When the software starts, the DAQ Startup screen shown in [Figure 5 on page 4](#) appears. With the board connected, the USB Status indicator displays "Connected 0x2032". The assigned HID code 0x2032 is verification that the software is communicating with the board.

Note: If the DAQ on a Stick is not connected, or a problem exists with the demonstration, the USB Status indicator displays "HID Device Not Found". If this message appears, click **Test USB Connection** to enable the connection. If the connection is still not enabled, disconnect and reconnect the device or restart the software.

3. From the DAQ Startup Screen ([Figure 5](#)), click **Instantaneous Voltage** to get a single voltage reading, select the sensor input to measure, and adjust the amplifier gain.
4. Click **Start** to go to the Measurement Display screen shown in [Figure 6](#). The green LED on the board turns off.

1.4 Connecting the Sensor

The RTKA-BDGSTKEV2Z reference design provides the option to measure the strain on a foil gauge (supplied with the evaluation board) or connect your own sensor and monitor the voltage reading in the software. Select **Sensor Supplied with the Demo** or **Customer Supplied** sensor by clicking the appropriate radio button on the DAQ Startup Screen (see [Figure 5](#)). The foil gauge is the default value in the software with a gain of 115V/V.

[Figure 4](#) shows the external connector inputs that connect the sensor to the circuit shown in [Figure 2](#).

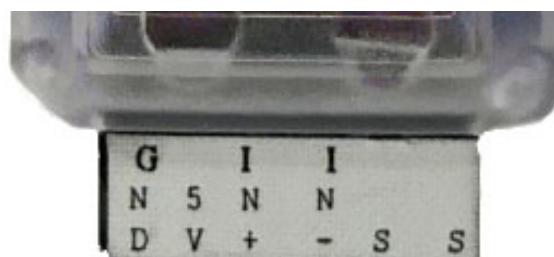

Figure 4. Sensor Connector

1.4.1 Connecting the Foil Strain Gauge

The foil gauge is supplied with the evaluation board. Complete the following steps to connect the foil gauge.

1. Plug the wires into the “S” ports (either top row or the bottom row; the columns are connected) on the DAQ on a Stick.
2. Connect the opposite end of the wires to the far edges of the foil gauge board. See [Figure 5](#).

1.4.2 Connecting the User Supplied Sensor

To connect your own sensor, complete the following steps.

1. Plug the wires into the IN+ and IN- ports shown in [Figure 4](#).
2. Select **Customer Supplied** in the DAQ Startup Screen, as shown in [Figure 5](#). This selection causes the ISL43840 configured as a differential mux to switch the inputs. When the **Customer Supplied** option is selected, you can change the amplifier gain for the best measurement.
3. The DAQ on a Stick also provides a 5V supply and Ground connection for possible use by your sensor network.

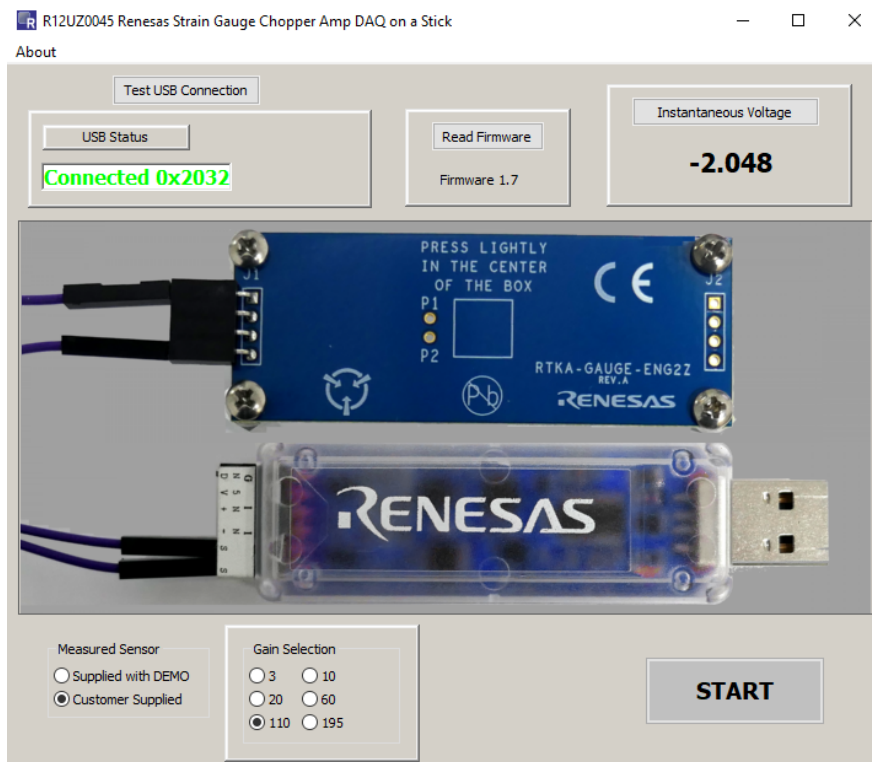

Figure 5. DAQ Startup Screen

Figure 6 shows the Measurement Display screen. From this screen, you can stop and start data collection, adjust the minimum and maximum X and Y axis, and go back to the setup screen by clicking Show Main. The Calibrate button zeroes out the voltage reading when the board is not under strain.

Calibration helps to give an accurate reading from time zero and is required because the board does not always return to the same deflection point after a strain is applied to the board.

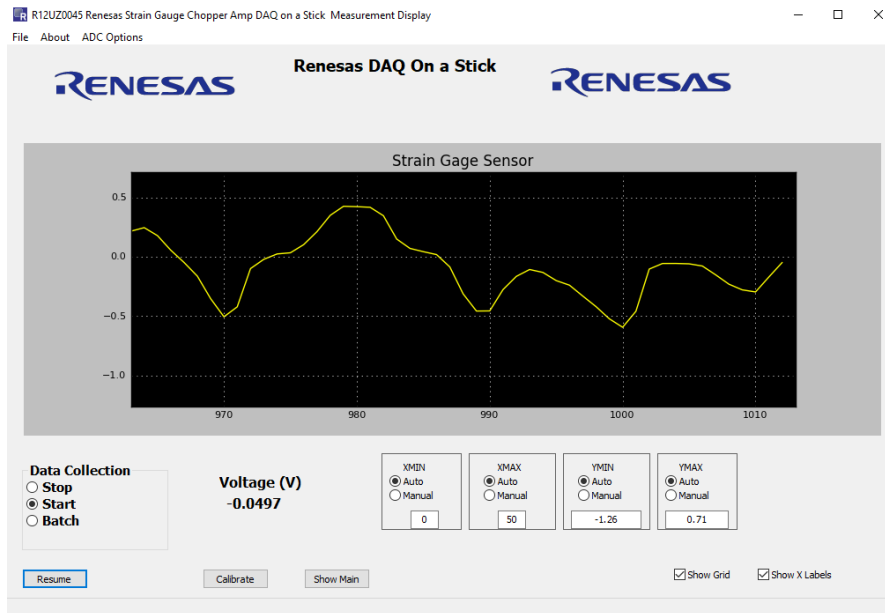

Figure 6. Measurement Display Screen

2. Design Considerations

2.1 ISL28134

The ISL28134 is an ideal choice for the input amplifier for a strain gauge design. The ISL28134 uses auto-correction circuitry to provide ultra low offset voltage (2.5 μ V) and low offset temperature drift (15nV/ $^{\circ}$ C). The very low 1/f noise corner (<0.1Hz) and low input noise voltage (8nV/ $\sqrt{\text{Hz}}$ at 100Hz) of the amplifier makes the ISL28134 ideal for low frequency precision applications requiring very high gain and low noise. Other key features of the ISL28134 are the wide gain bandwidth and rail-to-rail input/output swing.

2.2 ISL26102 24-Bit ADC

The ISL26102 is a complete analog front-end with dual differential multiplexed inputs for high resolution measurements. The ISL26102 features a third order modulator providing up to 21.4-bit noise-free performance (10Sps). The 24-bit delta-sigma analog-to-digital converter includes a very low-noise amplifier with programmable gain. Although this application demonstration uses an input buffer amplifier (ISL28134), the high input impedance of the ISL26102 allows direct connection of sensors such as load cell bridges to ensure the specified measurement accuracy without a buffer amplifier.

To initiate a correct power-up reset, diode D1, resistor R₃ and capacitor C₈ implement a simple RC delay to ensure the $\overline{\text{PDWN}}$ transitions from low to high after both power supplies have settled to specified levels.

2.3 ISL21010 (3.3V) Voltage Reference

The ISL21010CFH333 is a precision 3.3V, low dropout micropower band-gap voltage reference, which provides a $\pm 0.2\%$ accurate reference. The ISL21010 provides up to 25mA output current sourcing with low 150mV dropout voltage. The low supply current and low dropout voltage combined with high accuracy make the ISL21010 ideal for precision low powered applications.

2.4 ISL21010 (4.096V) Voltage Reference

The ISL21010CFH341 is a precision 4.096V, low dropout micropower band-gap voltage reference, which provides a $\pm 0.2\%$ accurate reference. The ISL21010 provides up to 25mA output current sourcing with low 150mV dropout voltage. The low supply current and low dropout voltage combined with high accuracy make the ISL21010 ideal for precision low powered applications.

2.5 ISL22316 DCP

The ISL22316 is a low noise, low power I²C™ bus, 128 tap DCP. The DCP can be used as a three-terminal potentiometer or as a two-terminal variable resistor in a wide variety of applications including control, parameter adjustments, and signal processing.

2.6 ISL43840 Low-Voltage, Dual 4-to-1 Multiplexer

The ISL43840 is a precision, bidirectional, analog switch configured as a dual 4-channel multiplexer/demultiplexer. In this design, the mux is configured as a differential mux. The mux is designed to operate from a single +2V to +12V supply or from a $\pm 2\text{V}$ to $\pm 6\text{V}$ supply. The ISL43840 has low charge injection with 1pC (maximum) at V_S = $\pm 5\text{V}$.

2.7 Bill of Materials

Part Number	Ref Des	Qty	Value	Tol.	Voltage	PWR	Package Type	JEDEC Type	MFR	Description
GRM21BR71C475KA73L	C1	1	4.7µF	10%	16V		805	CAP_0805	Murata	Ceramic Cap
Generic	C7, C12, C13, C20	4	0.01µF	10%	16V		402	CAP_0402	Various	Multilayer Cap
Generic	C5, C8, C9, C11, C14, C25, C27	7	0.1µF	10%	16V		402	CAP_0402	Various	Multilayer Cap
Generic	C21, C22	2	0.01µF	10%	25V		603	CAP_0603	Various	Multilayer Cap
250R07C100JV4T	C23, C24	2	10pF	5%	25V		402	CAP_0402RF	Johanson-Tech	C Series High-Q Chip Cap
Generic	C2, C3, C10, C26	4	1µF	20%	16V		603	CAP_0603	Various	Ceramic Cap
Generic	C6	1	0.33µF	10%	25V		603	CAP_0603	Various	Multilayer Cap
Generic	C17, C18	2	OPEN	5%	OPEN		603	CAP_0603	Various	Multilayer Cap
Generic	C15	1	2.2µF	10%	16V		805	CAP_0805	Various	Multilayer Cap
Generic	C4	1	10µF	10%	16V		1206	CAP_1206	Various	Multilayer Cap
597-3311-407	D1	1					SMD	DIA_LED1206	Dialight	Surface Mount Green LED
BAT54	D2	1					SINGLE	SOT23	Diodes	30V Schottky Diode
MMSD4148T1	D3 - D6	4					SOD123	SOD123	ON-Semi	Switching Diode
48037-1000	J1	1					MOLEX1	CON_USB_MOLEX_480371000	Molex	Right Angle USB A-Type Receptacle
PPPC062LJBN-RC	J2	1					DIP	CONN12	Sullins	12 Pin Header 2.54mmx2.54mm (.100) Connector RA
251206102Y1	L1	1	1µH				SMD	SM1206	Fair-Rite	Ferrite Bead
Generic	R7, R11, R27	3	0	0%		1/16W	402	RES_0402	Various	Thick Film Chip Resistor
Generic	R2, R3	2	100	1%		1/16W	402	RES_0402	Various	Thick Film Chip Resistor
Generic	R8	1	1k	1%		1/16W	402	RES_0402	Various	Thick Film Chip Resistor
Generic	R1, R4, R15, R16	4	10k	1%		1/16W	402	RES_0402	Various	Thick Film Chip Resistor
Generic	R28	1	220	1%		1/16W	402	RES_0402	Various	Thick Film Chip Resistor
Generic	R5, R6, R31	3	4.99k	1%		1/16W	402	RES_0402	Various	Thick Film Chip Resistor
Generic	R12, R13	2	49.9k	1%		1/16W	402	RES_0402	Various	Thick Film Chip Resistor
Generic	R9, R10	2	49.9	1%		1/16W	402	RES_0402	Various	Thick Film Chip Resistor

Part Number	Ref Des	Qty	Value	Tol.	Voltage	PWR	Package Type	JEDEC Type	MFR	Description
Generic	R30	1	DNP	0.1		DNP	603	RES_0603	Various	Thick Film Chip Resistor (Do Not Populate)
Generic	R14, R29	2	DNP	1%		DNP	402	RES_0402	Various	Thick Film Chip Resistor (Do Not Populate)
Generic	R20, R23, R26	3	1	0.1%		1/10W	805	RES_0805	Various	Thick Film Chip Resistor
Generic	R19, R22, R25	3	100	0.1%		1/10W	805	RES_0805	Various	Thick Film Chip Resistor
Generic	R18, R21, R24	3	249	0.1%		1/10W	805	RES_0805	Various	Thick Film Chip Resistor
ISL26102AVZ	U1	1					TSSOP	TSSOP24_173_256	Renesas	24 Pin 173 Mil TSSOP Package
ISL21010CFH341Z	U2	1					SOT	SOT23-3	Renesas	3 Pin SOT23-3 Package
ISL28134FHZ	U3, U4	2					SMD	SOT23-5	Renesas	5 Pin SOT23 Package
ISL43840IRZ	U5	1					QFN	QFN20_157X157_197_EP	Renesas	20 Lead Quad Flat Package (Pb-Free)
ISL22316UFRT	U6	1					DFN3X3B	TDFN10_118X118_197_EPB	Renesas	10 Lead 3 X 3 0.5 Pitch Thin Dual Flat Package with E-Pad
R5F10JBCANA	U7	1					QFN-S	QFN32_197X197_197_EPA	Renesas	32 Lead Quad Flat Package (Pb-Free)
IP422OCZ6	U8	1					SOT457	SOT457	NXP	Dual USB 2.0 Integrated ESD Protection
ISL54054IRUZ	U9	1					1_2X1A	UTDFN6_47X39_157_A	Renesas	6 Pin UTDFN-1.2X1A 0.4 Pitch Package
ISL21010CFH333Z	U10	1					SOT	SOT23-3	Renesas	3 Pin SOT23-3 Package
MCR03EZPF3001	R17	1	3k	1%		1/10W	603	RES_0603	ROHM	Metal Film Chip Resistor
PAD_50	P1, P2	2					THOLE	PAD-50	Various	0.050 Pad with 0.031 Plated Thru Hole
NX5032GA-12.000M-LN-CD-1	Y1	1					SM	XTAL_NX5032GA	NDK	12.000MHz SM Crystal

2.8 RTKA-BDGSTKEV2Z Evaluation Board Layout

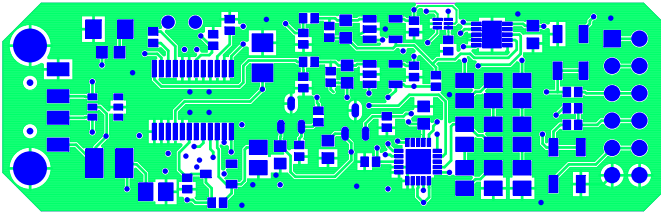

Figure 7. Top Layer

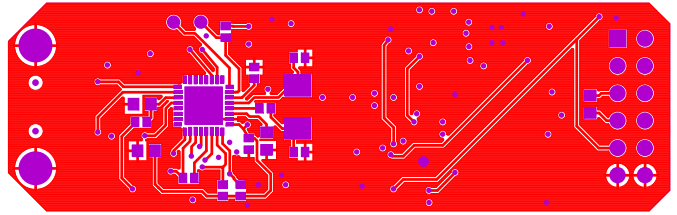

Figure 8. Bottom Layer

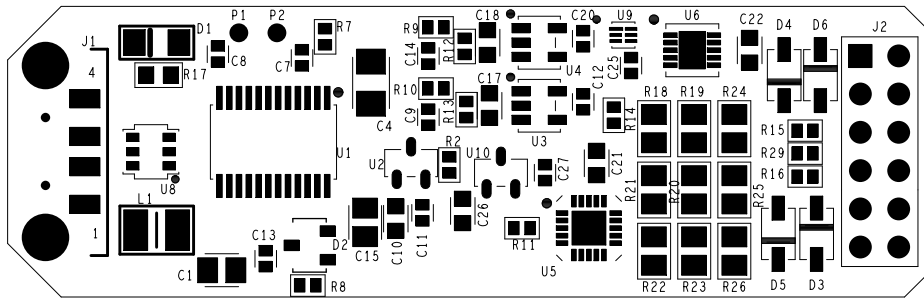

Figure 9. Top Assembly Drawing

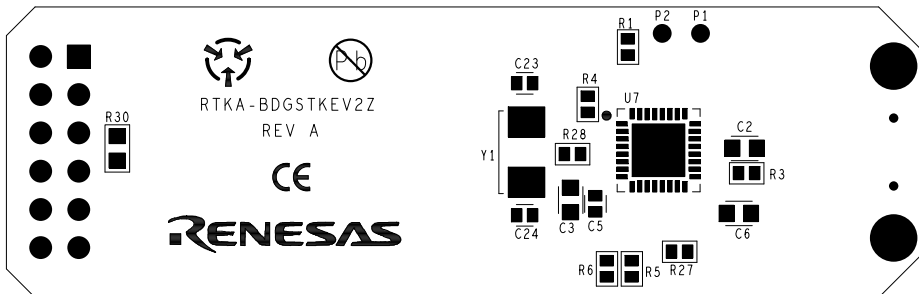
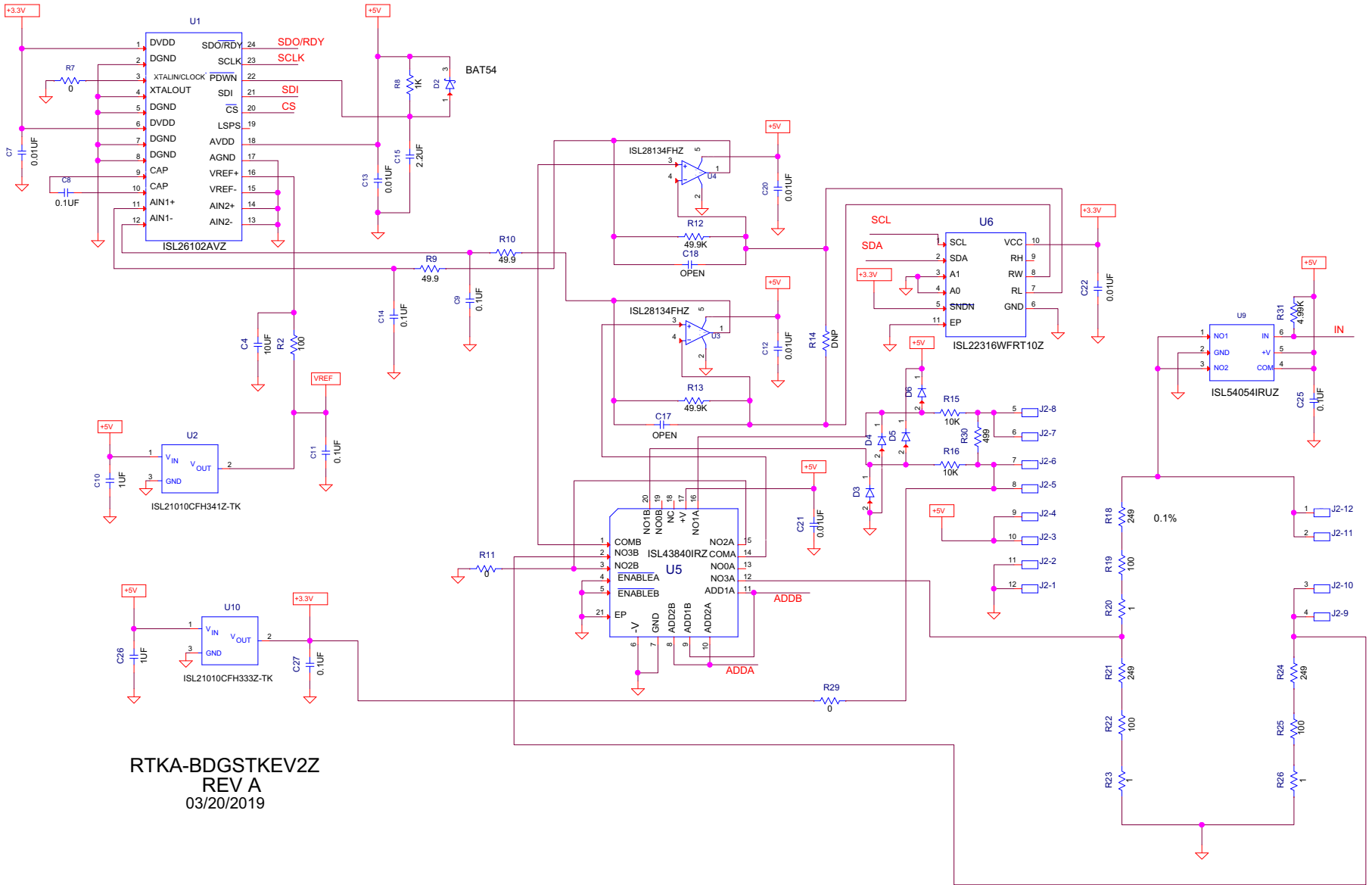

Figure 10. Bottom Assembly Drawing

2.9 RTKA-BDGSTKEV2Z Schematic



RTKA-BDGSTKEV2Z
REV A
03/20/2019

Figure 11. RTKA-BDGSTKEV2Z Strain Gauge Schematic

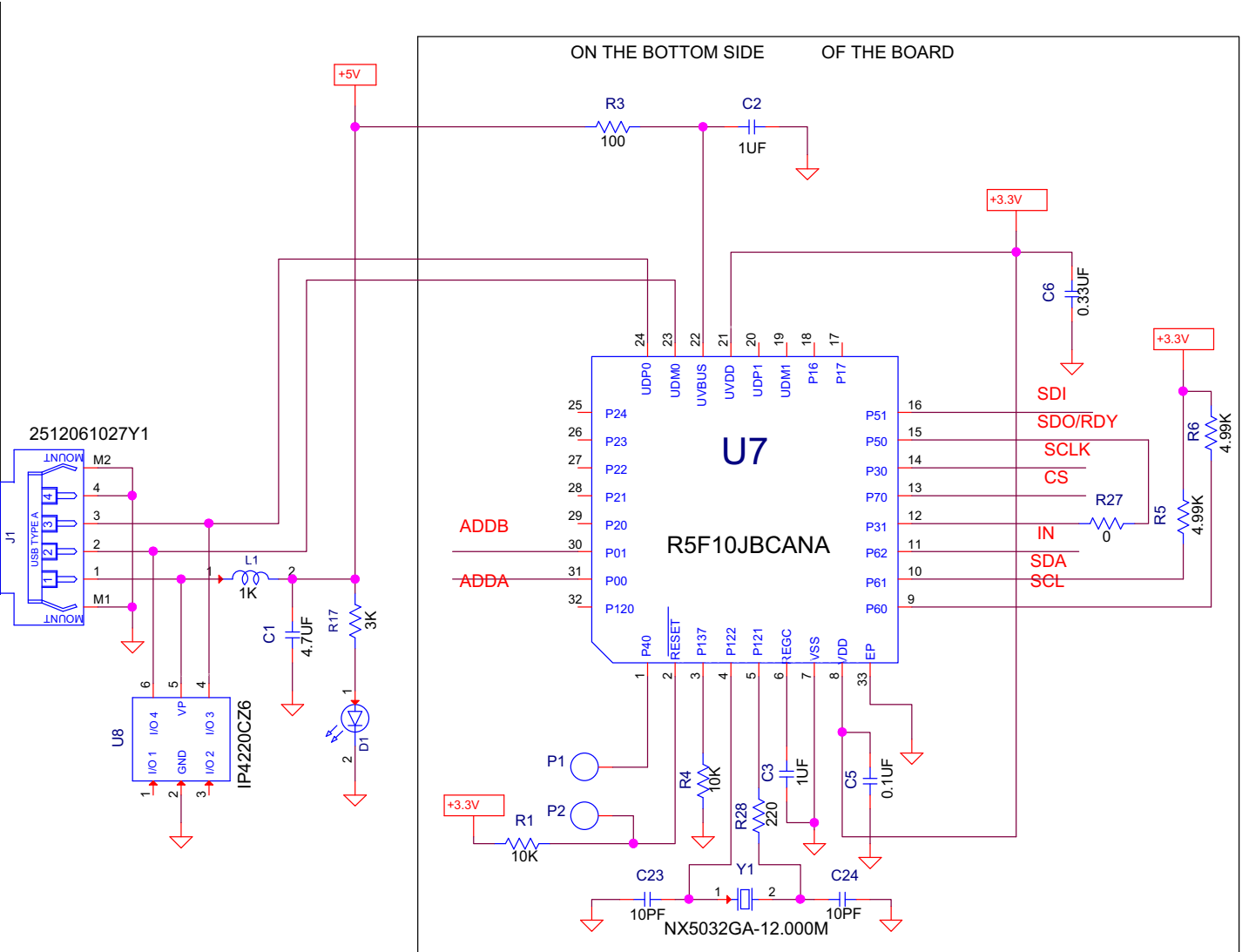

Figure 12. RTKA-BDGSTKEV2Z MCU Schematic

3. Revision History

Rev.	Date	Description
2.00	Jul.9.19	Updated Bill of Materials
1.01	Jun.5.19	Updated ISL21010 information.
1.00	Apr.5.19	Initial release.

Notice

1. Descriptions of circuits, software and other related information in this document are provided only to illustrate the operation of semiconductor products and application examples. You are fully responsible for the incorporation or any other use of the circuits, software, and information in the design of your product or system. Renesas Electronics disclaims any and all liability for any losses and damages incurred by you or third parties arising from the use of these circuits, software, or information.
2. Renesas Electronics hereby expressly disclaims any warranties against and liability for infringement or any other claims involving patents, copyrights, or other intellectual property rights of third parties, by or arising from the use of Renesas Electronics products or technical information described in this document, including but not limited to, the product data, drawings, charts, programs, algorithms, and application examples.
3. No license, express, implied or otherwise, is granted hereby under any patents, copyrights or other intellectual property rights of Renesas Electronics or others.
4. You shall not alter, modify, copy, or reverse engineer any Renesas Electronics product, whether in whole or in part. Renesas Electronics disclaims any and all liability for any losses or damages incurred by you or third parties arising from such alteration, modification, copying or reverse engineering.
5. Renesas Electronics products are classified according to the following two quality grades: "Standard" and "High Quality". The intended applications for each Renesas Electronics product depends on the product's quality grade, as indicated below.
 - "Standard": Computers; office equipment; communications equipment; test and measurement equipment; audio and visual equipment; home electronic appliances; machine tools; personal electronic equipment; industrial robots; etc.
 - "High Quality": Transportation equipment (automobiles, trains, ships, etc.); traffic control (traffic lights); large-scale communication equipment; key financial terminal systems; safety control equipment; etc.Unless expressly designated as a high reliability product or a product for harsh environments in a Renesas Electronics data sheet or other Renesas Electronics document, Renesas Electronics products are not intended or authorized for use in products or systems that may pose a direct threat to human life or bodily injury (artificial life support devices or systems; surgical implantations; etc.), or may cause serious property damage (space system; undersea repeaters; nuclear power control systems; aircraft control systems; key plant systems; military equipment; etc.). Renesas Electronics disclaims any and all liability for any damages or losses incurred by you or any third parties arising from the use of any Renesas Electronics product that is inconsistent with any Renesas Electronics data sheet, user's manual or other Renesas Electronics document.
6. When using Renesas Electronics products, refer to the latest product information (data sheets, user's manuals, application notes, "General Notes for Handling and Using Semiconductor Devices" in the reliability handbook, etc.), and ensure that usage conditions are within the ranges specified by Renesas Electronics with respect to maximum ratings, operating power supply voltage range, heat dissipation characteristics, installation, etc. Renesas Electronics disclaims any and all liability for any malfunctions, failure or accident arising out of the use of Renesas Electronics products outside of such specified ranges.
7. Although Renesas Electronics endeavors to improve the quality and reliability of Renesas Electronics products, semiconductor products have specific characteristics, such as the occurrence of failure at a certain rate and malfunctions under certain use conditions. Unless designated as a high reliability product or a product for harsh environments in a Renesas Electronics data sheet or other Renesas Electronics document, Renesas Electronics products are not subject to radiation resistance design. You are responsible for implementing safety measures to guard against the possibility of bodily injury, injury or damage caused by fire, and/or danger to the public in the event of a failure or malfunction of Renesas Electronics products, such as safety design for hardware and software, including but not limited to redundancy, fire control and malfunction prevention, appropriate treatment for aging degradation or any other appropriate measures. Because the evaluation of microcomputer software alone is very difficult and impractical, you are responsible for evaluating the safety of the final products or systems manufactured by you.
8. Please contact a Renesas Electronics sales office for details as to environmental matters such as the environmental compatibility of each Renesas Electronics product. You are responsible for carefully and sufficiently investigating applicable laws and regulations that regulate the inclusion or use of controlled substances, including without limitation, the EU RoHS Directive, and using Renesas Electronics products in compliance with all these applicable laws and regulations. Renesas Electronics disclaims any and all liability for damages or losses occurring as a result of your noncompliance with applicable laws and regulations.
9. Renesas Electronics products and technologies shall not be used for or incorporated into any products or systems whose manufacture, use, or sale is prohibited under any applicable domestic or foreign laws or regulations. You shall comply with any applicable export control laws and regulations promulgated and administered by the governments of any countries asserting jurisdiction over the parties or transactions.
10. It is the responsibility of the buyer or distributor of Renesas Electronics products, or any other party who distributes, disposes of, or otherwise sells or transfers the product to a third party, to notify such third party in advance of the contents and conditions set forth in this document.
11. This document shall not be reprinted, reproduced or duplicated in any form, in whole or in part, without prior written consent of Renesas Electronics.
12. Please contact a Renesas Electronics sales office if you have any questions regarding the information contained in this document or Renesas Electronics products.

(Note1) "Renesas Electronics" as used in this document means Renesas Electronics Corporation and also includes its directly or indirectly controlled subsidiaries.

(Note2) "Renesas Electronics product(s)" means any product developed or manufactured by or for Renesas Electronics.

(Rev.4.0-1 November 2017)

Corporate Headquarters

TOYOSU FORESIA, 3-2-24 Toyosu,
Koto-ku, Tokyo 135-0061, Japan
www.renesas.com

Contact Information

For further information on a product, technology, the most up-to-date version of a document, or your nearest sales office, please visit:
www.renesas.com/contact/

Trademarks

Renesas and the Renesas logo are trademarks of Renesas Electronics Corporation. All trademarks and registered trademarks are the property of their respective owners.

RTKA-BDGSTKEV2Z