

RTK7RL23LMP00000BJ Schematics Rev. B

RL78/G23 Lighting Communication Master Evaluation Board

Contents

P01 TOP
P02 MCU
P03 DALI/DMX
P04 MCU Power
P05 USB/OCD
P06 Touch Key

Revision History

Date	Rev	Description
2022.12.5	V1.00	*First Revision

o e

This document is reference.

There may be cases where that differs from the actual state.

Power types

VBUS	Extarnal power supply	5.0V/2A max
5V	Internal power supply	5.0V/2A max
3.3V	Internal power supply	3.3V/2A max
17.5V	Internal power supply	17.5V/1A max

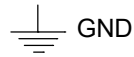

Board silk

Board Name	RL78/G23 Lighting Communication Master Evaluation Board
PCB No.	RTK7RL23LMP00000BJ
Country of production	MADE IN JAPAN
Display 1	UL mark
Display 2	RoHS Compliant
Display 3	Anti Static
Display 4	WEEE
Display 5	CE
Display 6	China-RoHS(10 years)

Renesas Electronics Corporation	
Title RTK7RL23LMP00000BJ Schematics Rev. B	
Size A3	Document Number R20UT5173EJ0100
Date: December 5, 2022	Rev 1.00
Sheet 1 of 6	

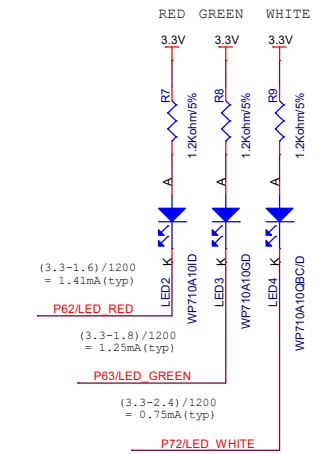
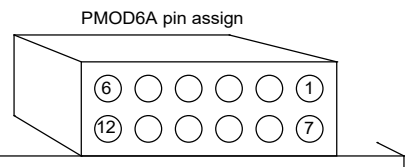
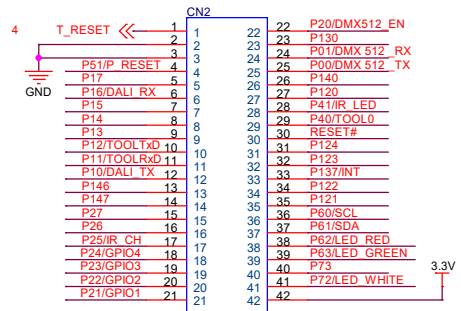
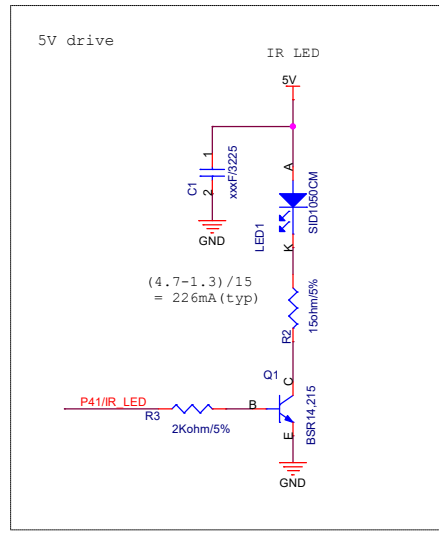
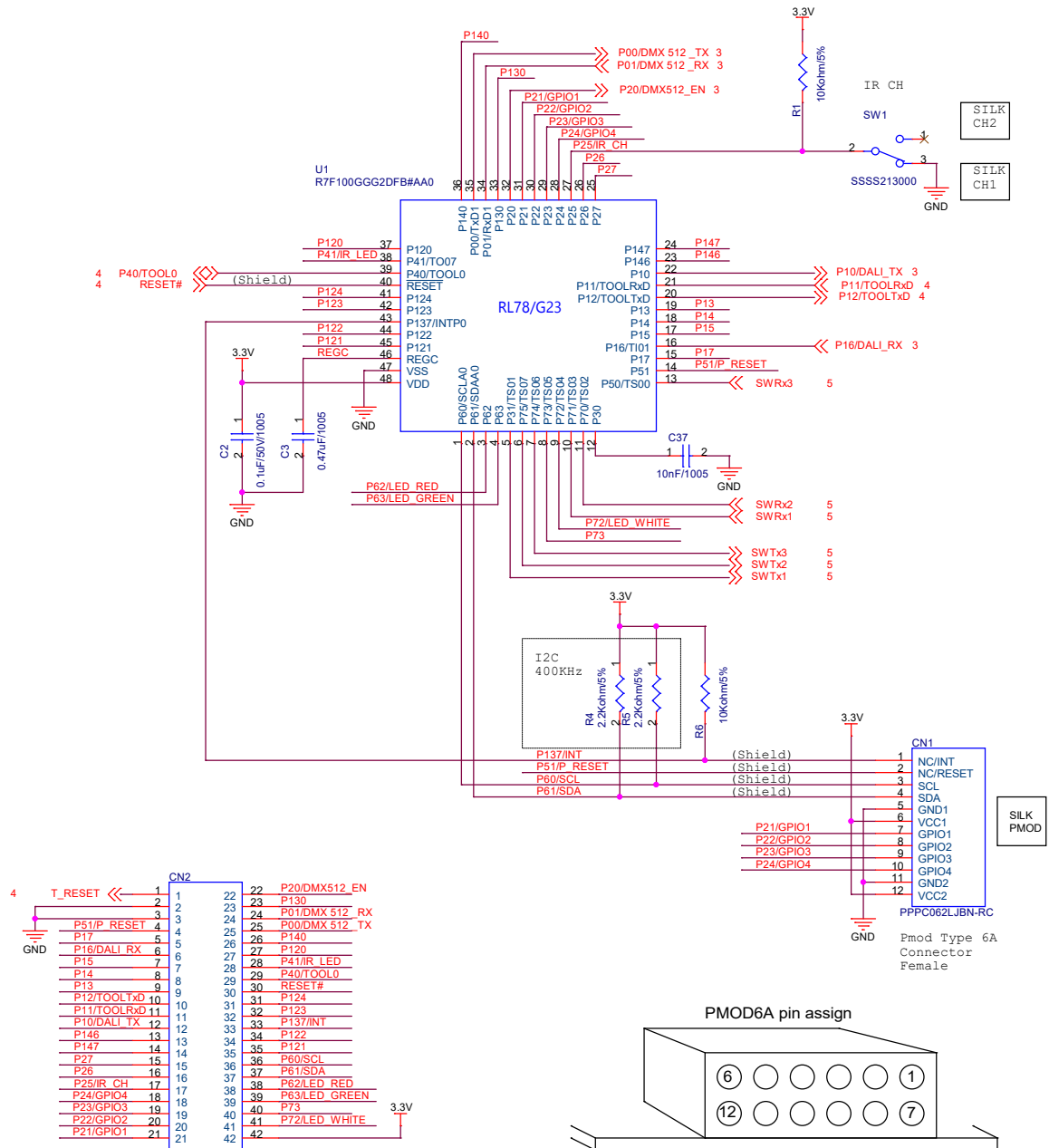

FFC-42BMEP1
Expansion Terminal
Male(Unmount)

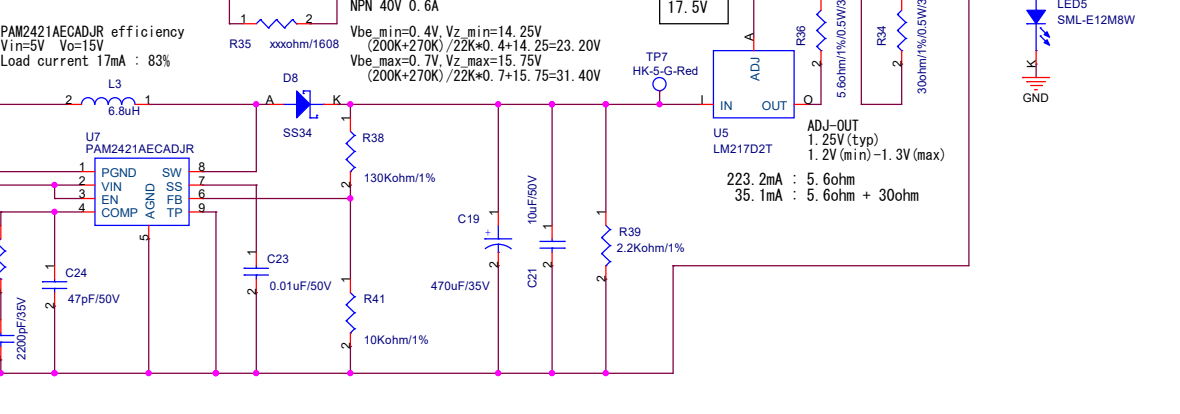
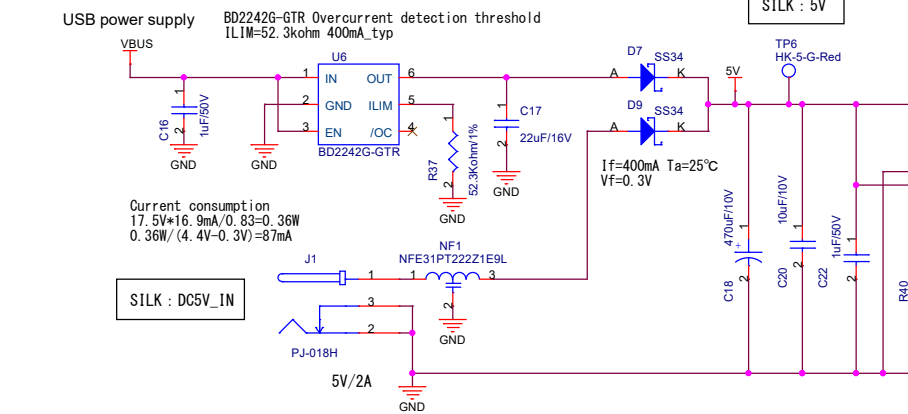
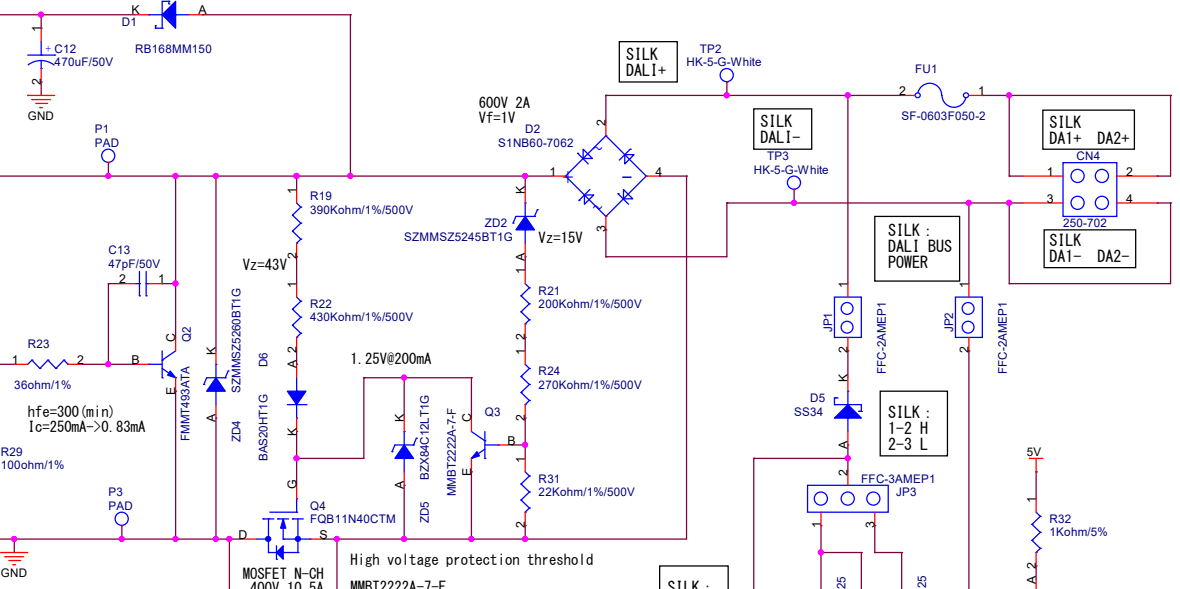
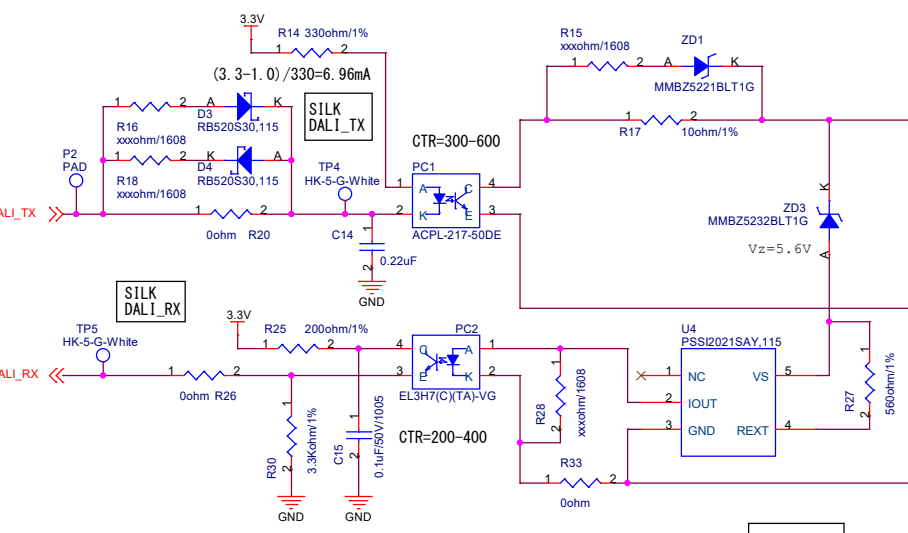
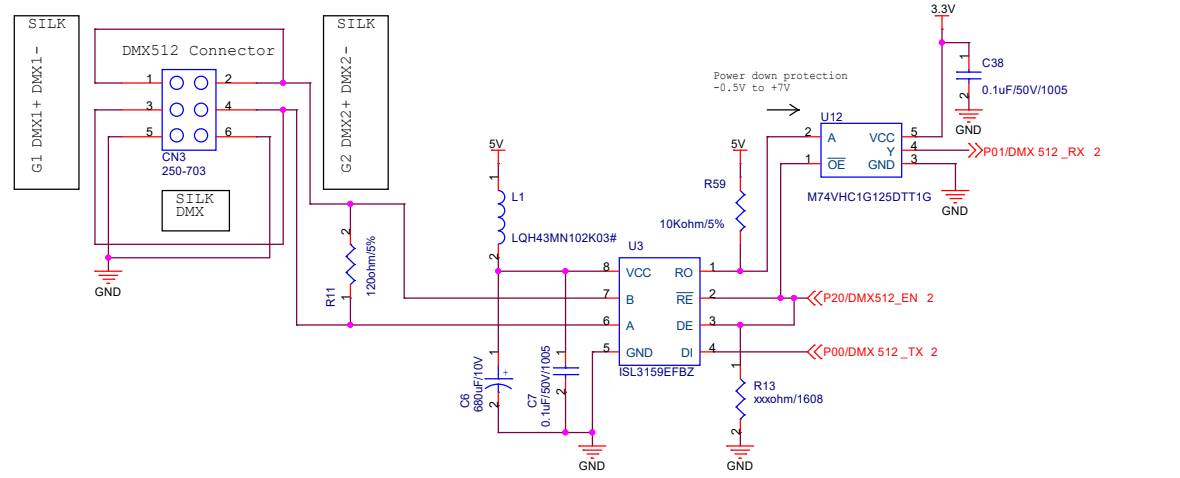
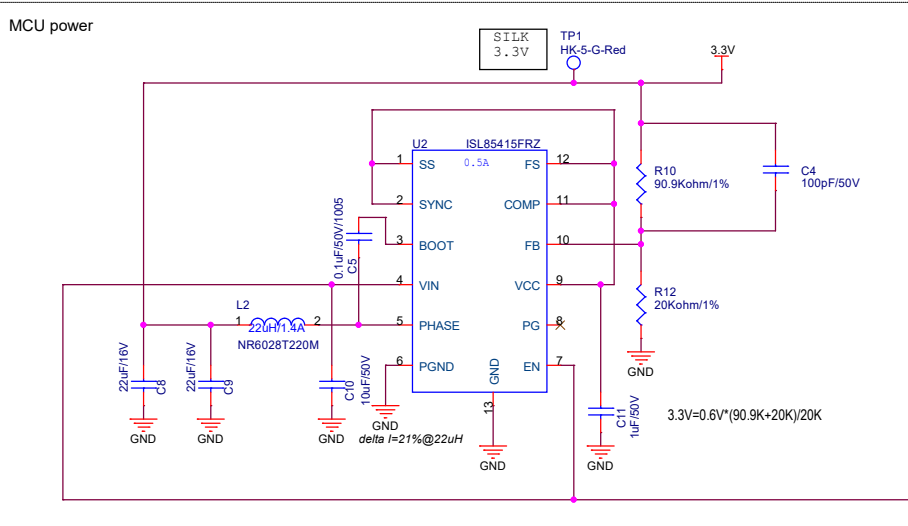

When USB power supply is OFF, LVC1T45 are disabled. (HI-Z)

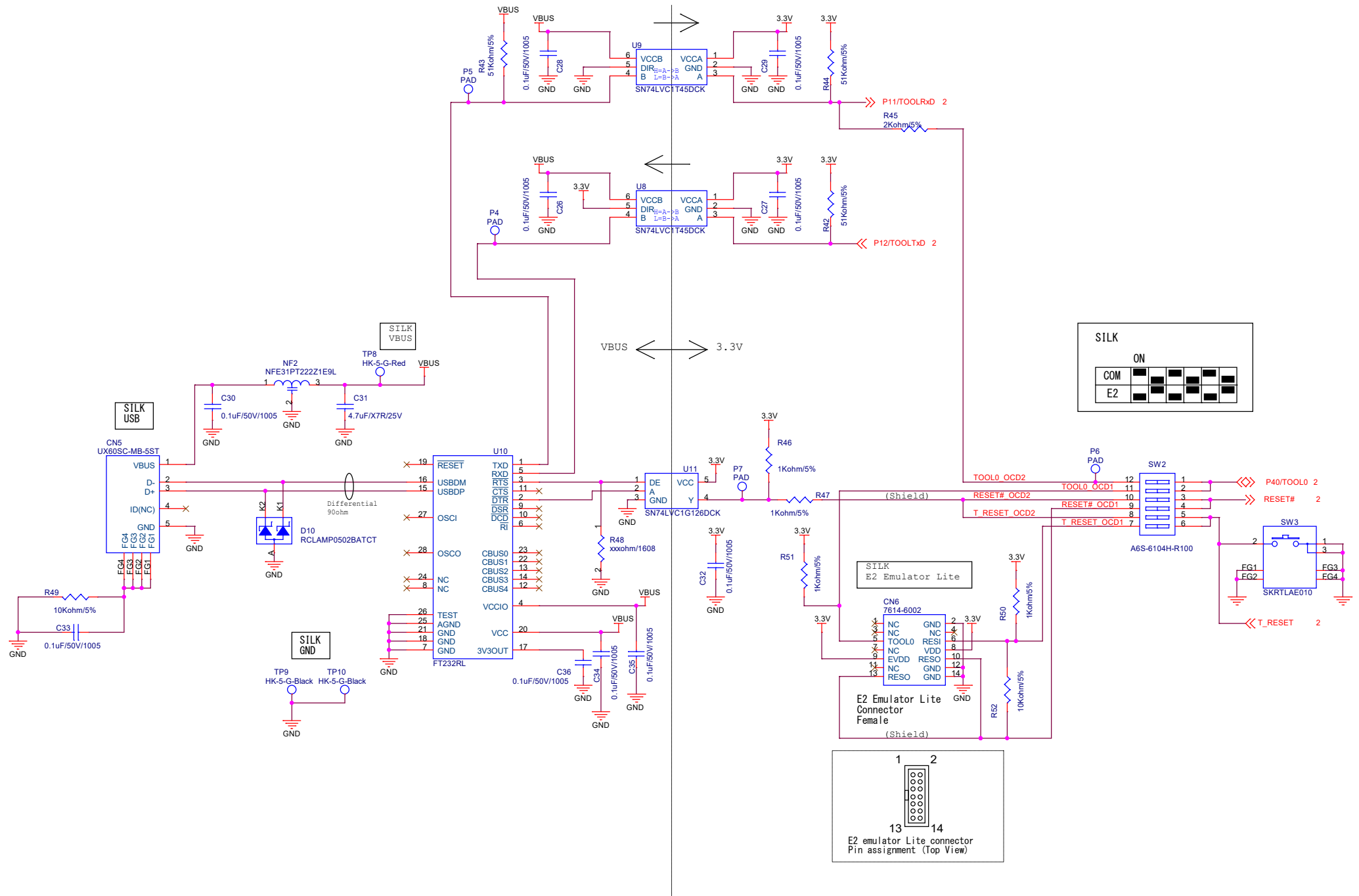

Mutual capacitance touch sensor
3x3 matrix switch electrode circuit

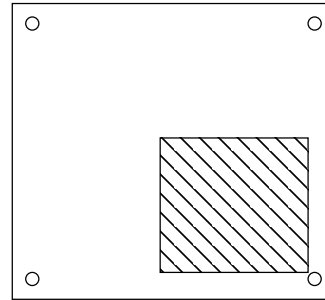
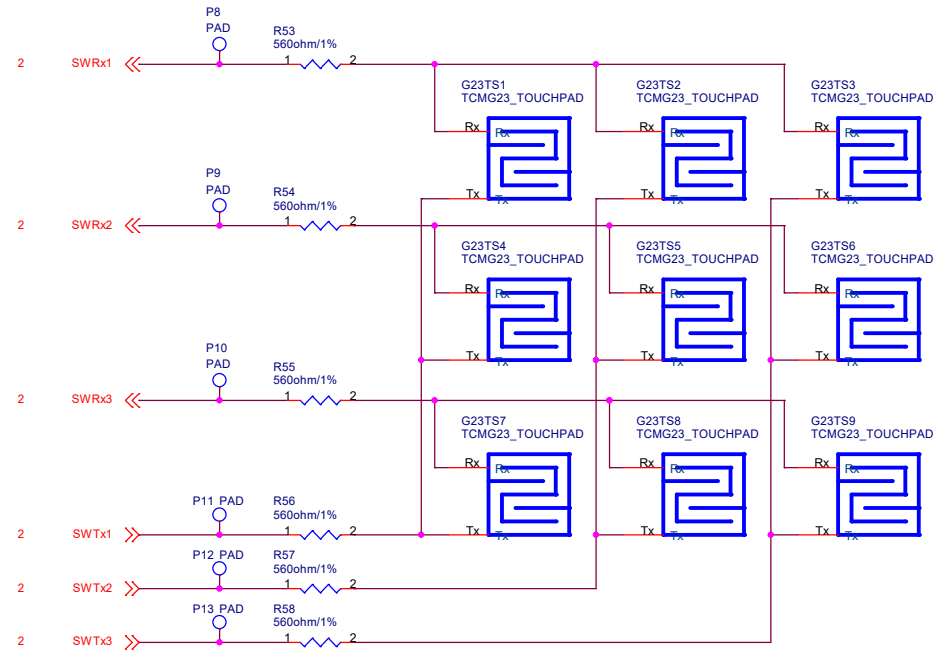

Place the touch sensor key position as close to the edge of the board as possible to avoid interference with other parts.