

YRSPSH7267-0103



**Renesas Starter Platform for SH7267
User's Manual**

RENESAS SINGLE-CHIP MICROCOMPUTER
SuperHTM RISC engine

Disclaimer

By using this Renesas Starter Platform (RSP), the user accepts the following terms. The RSP is not guaranteed to be error free, and the entire risk as to the results and performance of the RSP is assumed by the User. The RSP is provided by Renesas on an “as is” basis without warranty of any kind whether express or implied, including but not limited to the implied warranties of satisfactory quality, fitness for a particular purpose, title and non-infringement of intellectual property rights with regard to the RSP. Renesas expressly disclaims all such warranties. Renesas or its affiliates shall in no event be liable for any loss of profit, loss of data, loss of contract, loss of business, damage to reputation or goodwill, any economic loss, any reprogramming or recall costs (whether the foregoing losses are direct or indirect) nor shall Renesas or its affiliates be liable for any other direct or indirect special, incidental or consequential damages arising out of or in relation to the use of this RSP, even if Renesas or its affiliates have been advised of the possibility of such damages.

Precautions

This Renesas Starter Platform is only intended for use in a laboratory environment under ambient temperature and humidity conditions. A safe separation distance should be used between this and any sensitive equipment. Its use outside the laboratory, classroom, study area or similar such area invalidates conformity with the protection requirements of the Electromagnetic Compatibility Directive and could lead to prosecution.

The product generates, uses, and can radiate radio frequency energy and may cause harmful interference to radio communications. However, there is no guarantee that interference will not occur in a particular installation. If this equipment causes harmful interference to radio or television reception, which can be determined by turning the equipment off or on, you are encouraged to try to correct the interference by one or more of the following measures;

- ensure attached cables do not lie across the equipment
- reorient the receiving antenna
- increase the distance between the equipment and the receiver
- connect the equipment into an outlet on a circuit different from that which the receiver is connected
- power down the equipment when not in use
- consult the dealer or an experienced radio/TV technician for help NOTE: It is recommended that wherever possible shielded interface cables are used.

The product is potentially susceptible to certain EMC phenomena. To mitigate against them it is recommended that the following measures be undertaken;

- The user is advised that mobile phones should not be used within 10m of the product when in use.
- The user is advised to take ESD precautions when handling the equipment.

The Renesas Starter Platform does not represent an ideal reference design for an end product and does not fulfil the regulatory standards for an end product.

Table of Contents

Chapter 1. Preface	1
Chapter 2. Purpose	2
Chapter 3. Power Supply	3
3.1. Requirements	3
3.2. Power-up Behaviour	3
Chapter 4. Board Layout	4
4.1. Component Layout	4
4.2. Board Dimensions	5
Chapter 5. Block Diagram	6
Chapter 6. User Circuitry.....	7
6.1. Switches	7
6.2. LEDs	7
6.3. Potentiometer	7
6.4. Serial port	8
6.5. Debug LCD Module	8
6.6. RCAN	9
6.7. USB	9
6.8. ETHERNET	10
6.9. LCD Interface	10
6.10. SSI	11
6.11. SD Card	11
6.12. Video Decoder	12
6.13. Option Links.....	13
6.14. Oscillator Sources	15
6.15. Reset Circuit.....	16
Chapter 7. Modes.....	17
7.1. Boot modes	17
7.2. Clock operating modes.....	17
Chapter 8. Programming Methods.....	18
Chapter 9. Headers.....	19
9.1. Generic Headers	19
9.2. Generic TFT LCD Header	20
Chapter 10. Code Development	22
10.1. Overview.....	22
10.2. Compiler Restrictions	22
10.3. Breakpoint Support.....	22
10.4. Memory Map.....	23
Chapter 11. Component Placement.....	24

Chapter 1. Preface

Cautions

This document may be, wholly or partially, subject to change without notice.

All rights reserved. Duplication of this document, either in whole or part is prohibited without the written permission of Renesas Electronics America.

Trademarks

All brand or product names used in this manual are trademarks or registered trademarks of their respective companies or organisations.

Copyright

© 2012 Renesas Electronics America. All rights reserved.

Website: www.renesas.com

Glossary

ADC	Analog to Digital Converter	SCI	Serial Communication Interface
CD	Compact Disc	SD	Secure Digital
CPU	Central Processing Unit	SDRAM	Synchronous Dynamic Random Access Memory
DAC	Digital to Analog Converter	SPDIF	Sony/Philips Digital Interface
E10A	'E10A for Starter Platforms'	SSI	Serial Sound Interface
Debugger	EMC Electromagnetic compatibility	USB	Universal Serial Bus
ESD	Electrostatic Discharge		
HEW	High-Performance Embedded Workshop		
H-UDI	Hitachi - User Debug Interface		
I/O	Input / Output		
LCD	Liquid Crystal Display		
LED	Light Emitting Diode		
MCU	Microcontroller Unit		
PC	Personal Computer		
RAM	Random Access Memory		
RCAN	Renesas Controller Area Network		
ROM	Read-Only Memory		

Chapter 2. Purpose

This RSP is an evaluation tool for Renesas microcontrollers.

Features include:

- Renesas Microcontroller Programming.
- User Code Debugging.
- User Circuitry such as switches, LEDs and potentiometer(s).
- Sample Application.
- Sample peripheral device initialisation code.

The RSP board contains all the circuitry required for microcontroller operation.

This manual describes the technical details of the RSPSH7267 hardware. The Quick Start Guide and Tutorial Manual provide details of the software installation and debugging environment.

Chapter 3. Power Supply

3.1. Requirements

This CPU board can operate from a 5V center positive power supply.

Table 3-1 and **Table 3-2** below details the power supply connectors available on this RSP board

CN7			
Pin	CPU board Signal Name	Pin	CPU board Signal Name
1	5VCC	2	5VCC
3	GROUND	4	GROUND

Table 3-1: Power Supply Connector CN7

CN8*			
Pin	CPU board Signal Name	Pin	CPU board Signal Name
1	5VCC	2	NC
3	GROUND		

Note: The connector CN8 is underneath the board and is not normally installed.

Table 3-2: Power Supply Connector CN8

Warning - Care must be taken to ensure that an appropriate supply is used. Failing to do this may cause permanent damage to the board.

This RSP board is supplied with an E10A debugger.

This RSP boards have a centre positive supply connector using a 2.0mm barrel power jack.

Warning - The CPU board is not over voltage protected. Use a centre positive supply for this board.

3.2. Power-up Behavior

When the RSP is purchased the CPU board has the 'Release' or stand alone code from the example tutorial code pre-programmed into the Renesas microcontroller. On powering up the board, the user LEDs will start to flash. Pressing any switch will cause the LEDs to flash at a rate controlled by the potentiometer.

Chapter 4. Board Layout

4.1. Component Layout

The following diagram shows the top layer component layout of the board.

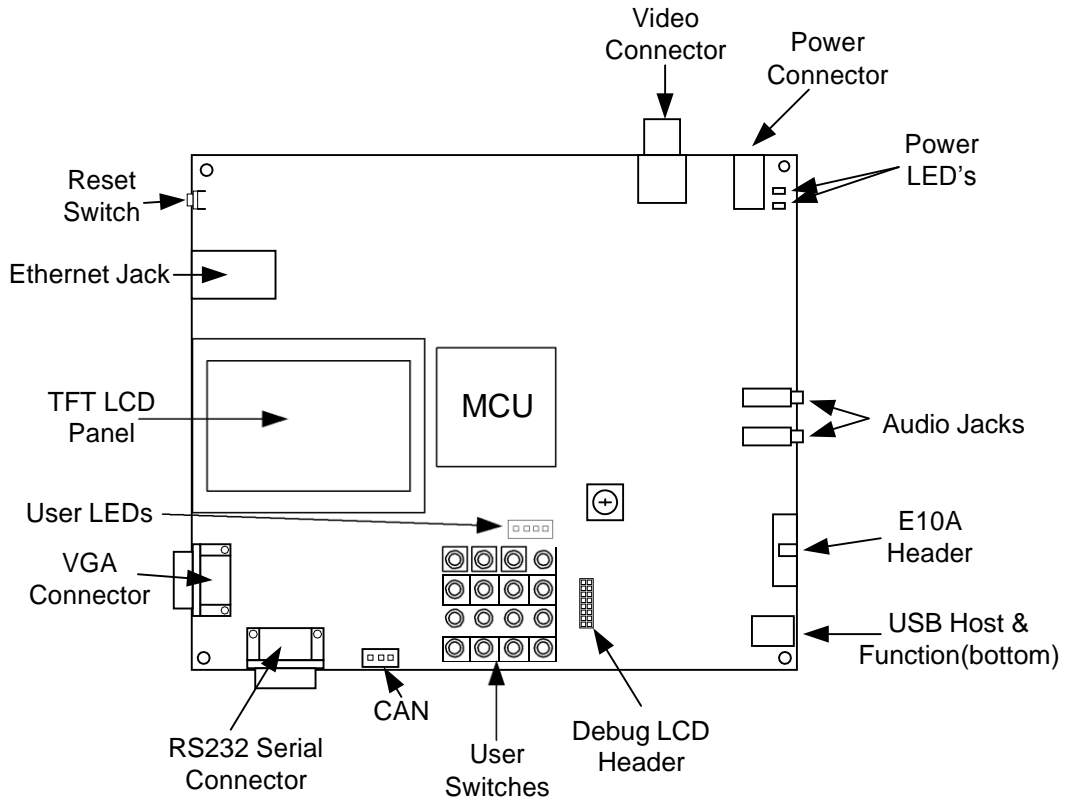

Figure 4-1: Board Layout

4.2. Board Dimensions

The following diagram gives the board dimensions and connector positions.

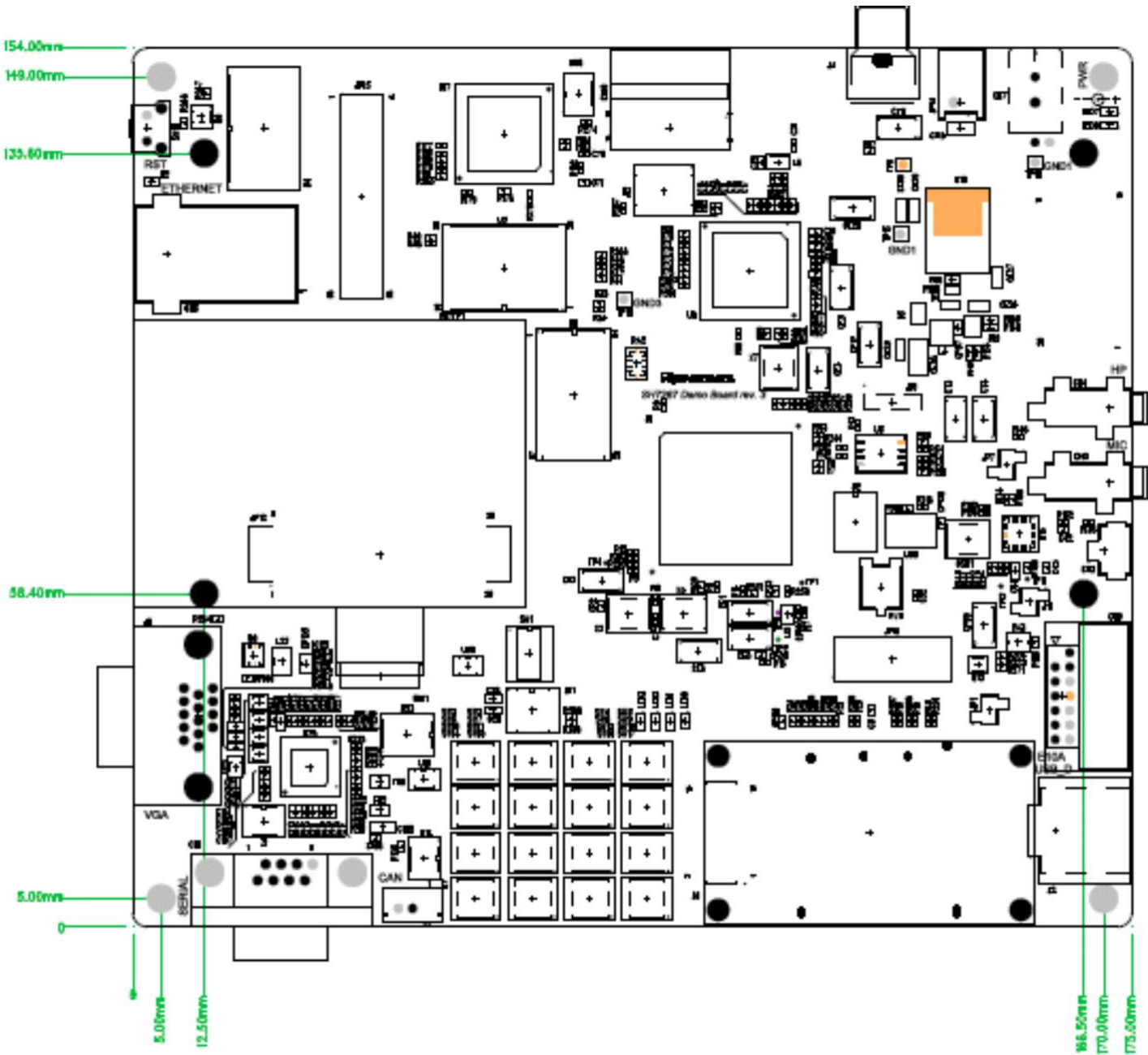

Figure 4-2: Board Dimensions

Chapter 5. Block Diagram

Figure 5-1 shows the CPU board components and their connectivity.

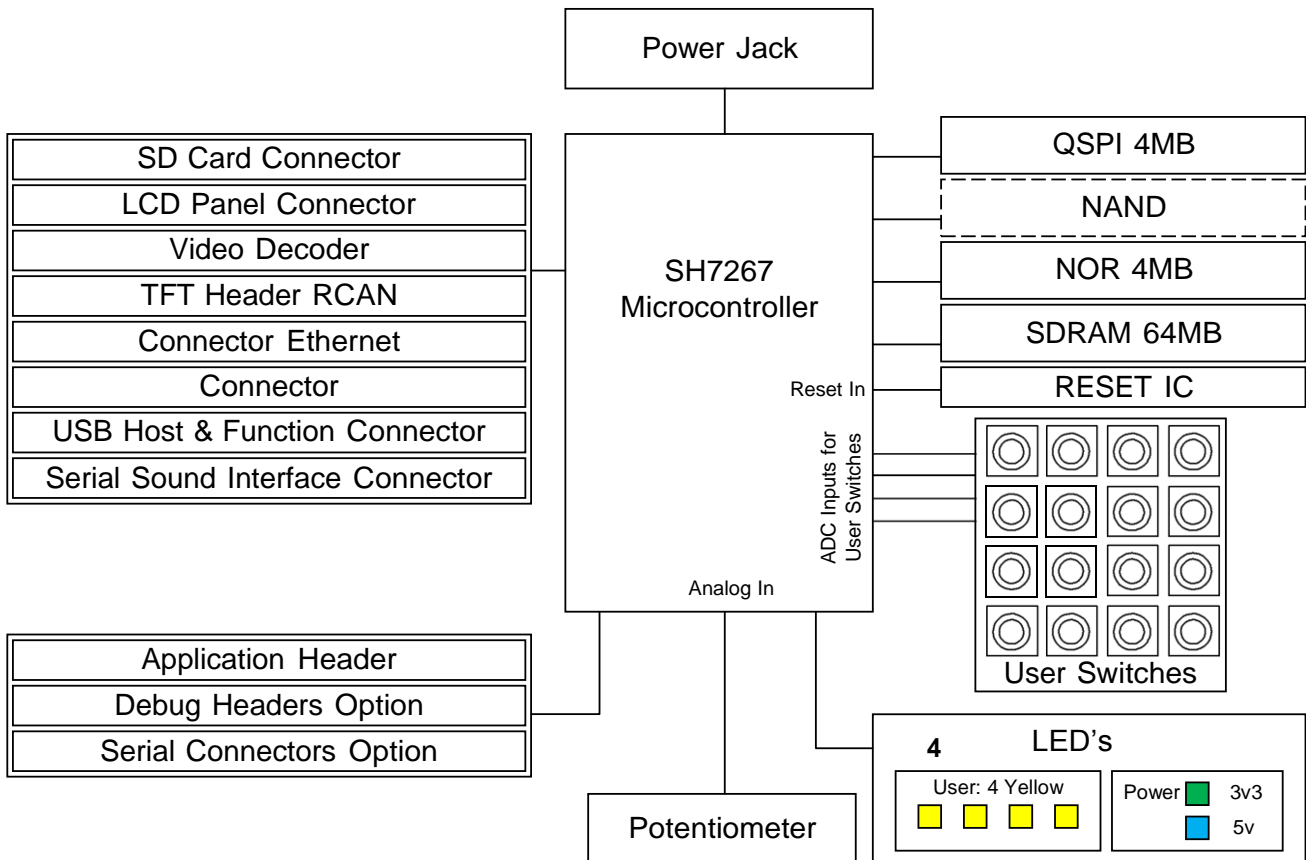

Figure 5-1: Block Diagram

Figure 5-2 shows E10A connections to the RSP board.

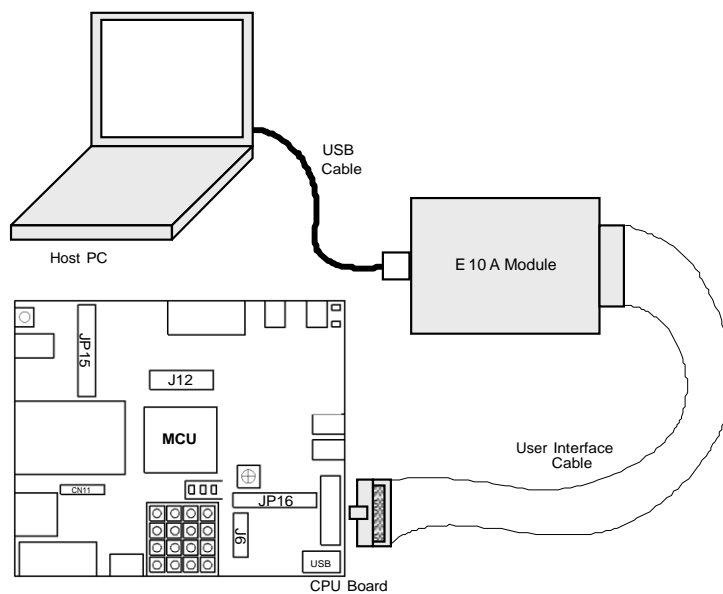

Figure 5-2: E10A RSP Connections

Chapter 6. User Circuitry

6.1. Switches

There are 16 user switches connected in matrix form on the board in addition to the reset switch. They are connected to 4 ADC input Pins of the MCU. The function of each switch and its connection are shown in **Table 6-1**

Switch	Function	Microcontroller
RST / SW18	When pressed, the microcontroller is reset.	RES#, Pin 46
SW2	User Switch	PH0/AN0, Pin 80
SW3	User Switch	PH0/AN0, Pin 80
SW4	User Switch	PH0/AN0, Pin 80
SW5	User Switch	PH0/AN0, Pin 80
SW6	User Switch	PH1/AN1, Pin 81
SW7	User Switch	PH1/AN1, Pin 81
SW8	User Switch	PH1/AN1, Pin 81
SW9	User Switch	PH1/AN1, Pin 81
SW10	User Switch	PH2/AN2, Pin 82
SW11	User Switch	PH2/AN2, Pin 82
SW12	User Switch	PH2/AN2, Pin 82
SW13	User Switch	PH2/AN2, Pin 82
SW14	User Switch	PH3/AN3, Pin 83
SW15	User Switch	PH3/AN3, Pin 83
SW16	User Switch	PH3/AN3, Pin 83
SW17	User Switch	PH3/AN3, Pin 83

Table 6-1: Switch Functions

6.2. LEDs

There are 7 LEDs on the RSP board. The green 'POWER' LED (LED8) lit when a 3.3V supply is connected to the power net 3VCC and blue 'POWER' LED (LED7) lights when the board is powered with 5V. The four user LEDs are connected to an IO port and will lit when their corresponding port pin is set low. An Orange LED (D2) will light when Ethernet connection is established.

Table 6-2 below shows the LED pin references and their corresponding microcontroller port pin connections.

LED Reference (As shown on silkscreen)	Colour	Microcontroller Port Pin function	Microcontroller Pin Number	Polarity
LED1	Yellow	PE4	134	Active Low
LED2	Yellow	PE5	133	Active Low
LED3	Yellow	PG20	58	Active Low
LED9	Yellow	PA_B0	48 (external buffered)	Active Low

Table 6-2: LED Port

6.3. Potentiometer

A single-turn potentiometer is connected to pin AN4 of the microcontroller. This may be used to vary the input analog voltage value to this pin between AVCC and Ground.

Note: The potentiometer is fitted to offer an easy way of supplying a variable analog input to the controller. It does not necessarily reflect the accuracy of the controller's ADC. Please see the device manual for details.

6.4.Serial port

The RS232 port is available at connector 'CN1' and uses microcontroller serial port SCIF0 for asynchronous serial communication. The board is designed to accept a straight-through RS-232 male-to-female cable.

6.5.Debug LCD Module

The LCD module supplied with the RSP can be connected to the connector 'J6' for use with the tutorial code. Any module that conforms to the pin connections and has a KS0066u compatible controller can be used. The LCD module uses a 4bit interface to reduce the pin allocation. No contrast control is provided; this must be set on the display module.

The module supplied with the CPU board only supports 5V operation.

Table 6-3 shows the pin allocation and signal names used on this connector.

J6 (For LCD)					
Pin	Circuit Net Name	Device Pin	Pin	Circuit Net Name	Device Pin
1	Ground	-	2	5VCC	-
3	No Connection	-	4	PE4	134
5	R/W (Wired to write only using 10K pull down))	-	6	PE5 (+ 10k pull down to ground)	133
7	No Connection	-	8	No Connection	-
9	No Connection	-	10	No Connection	-
11	PG20	58	12	PA_B0	48 *
13	PA_B1	49*	14	PA_B2	62 *

Table 6-3: Debug LCD Module Connections

Note [*]: These pins are externally buffered.

6.6. RCAN

The SH7267 on-chip RCAN module offers a flexible and sophisticated way to organize and control CAN frames, providing the compliance to CAN2.0B Active and ISO-11898-1. There are 2 CAN channels available on the microcontroller but only one transceiver is available on the board. By default CAN0 is connected to the CAN transceiver. Option links provide easy interface to connect CAN1 channel to the transceiver instead of CAN0.

Table 6-4 details the required connections to connect either CAN0 or CAN1 channel to the transceiver –

CAN channel	Option Links R277, R278	Option Links R275, R276
CAN0	Fitted	Removed
CAN1	Removed	Fitted

Note: The default CAN setting on this RSP is indicated by **BOLD** text.

Table 6-4: CAN Channel Selection

Table 6-5 details the CAN connectors available on this RSP board –

CAN0		
Pin	Circuit Net Name	Device Pin
1	CANH	105 * (CTX1)
2	CANL	104* (CRX1)
3	GND	-

* - The RCAN transceivers translate the voltage levels on CPU pin to meet RCAN voltage level standards.

Table 6-5: RCAN Connector

For more details on SH7267 on-chip RCAN module, please refer to *SH7267 Group Hardware Manual*.

6.7. USB

The USB 2.0 host/function module (USB) provides capabilities as a USB host and USB function. It supports high-speed and full-speed transfers defined by USB 2.0 specification. The Low speed mode is not supported. This module has a USB transceiver and supports all of the transfer types defined by the USB specification. The module has an 8-kbyte on-chip buffer memory for data transfer, providing a maximum of ten pipes. Any endpoint numbers can be assigned to PIPE1 to PIPE9, based on the peripheral devices or user system for communication.

Table 6-6 below details the USB connectors available on this RSP board

USB Socket-A (USB Host) JP1 (1-2) short				USB Mini-B (USB Device / Function) JP1 (1-2) open			
Pin No	Pin Name	Circuit Net Name	Device Pin	Pin No	Pin Name	Circuit Net Name	Device Pin
1	VBUS	VBUS	70	1	VBUS	VBUS	70
2	D-	DM	68	2	D-	DM	68
3	D+	DP	69	3	D+	DP	69
4	GND	GROUND	---	4	ID	USB_ID	NC
5	FG2	USB_SHLD	---	5	GND	GROUND	---
6	FG1	USB_SHLD	---	6	FRAME	USB_SHLD	---
				7	FG1	USB_SHLD	---
				8	FG2	USB_SHLD	---
				9	FG3	USB_SHLD	---

Table 6-6: USB

For more details on SH7267 on-chip USB module, please refer to SH7267 *Group Hardware Manual*.

6.8. ETHERNET

The network functionality is provided by the SMSC LAN9218, a single-chip 10/100 Ethernet controller which incorporates essential protocol requirements for operating an Ethernet/IEEE 802.3 10BASE-T and 802.3u100BASE-TX node. The Ethernet controller is configured to use a 16 bit data bus. It uses single 16 bit read and write strobes. Byte accesses are not available for this device. The chip select used for the network controller is CS4.

The orange LED (D2) lights when Full-Duplex connection is established between the PHY device and any other connected Ethernet devices. The embedded Ethernet connector green LED lights when there is a link with the other devices. The yellow LED lights when there is a network activity.

Refer to the *SMCS LAN9218 datasheet* for more information on this peripheral.

Table 6-7 contains details of the signal descriptions and pin connections.

LED Reference (As shown on silkscreen)	Colour	LAN89218 Port Pin	LAN9218 Pin Number
DUPLEX	Orange	GPIO2_LED3#	100
Ethernet connector: LED_K_YELLOW	Yellow	GPIO0_LED1#	98
Ethernet connector: LED_K_GREEN	Green	GPIO1_LED2#	99

Table 6-7: Ethernet module settings

6.9. LCD Interface

Video Display Controller 3 in SH7267 supports TFT-LCD panel. Video Display Controller 3 uses the display and recording function to store the input data in the memory and then display the video on the panel. NEC NL2432HC17-07B TFT LCD panel has been used on RSPSH7267 board. This panel has a resolution of 240 x 320 pixels. This panel is fitted at CN11 connector.

Table 6-8 below details the pin connections for CN11 connector available on this RSP board

CN11 (For NEC LCD)					
Pin	CPU board Signal Name	Device Pin	Pin	CPU board Signal Name	Device Pin
1	GROUND	---	2	GROUND	---
3	3VCC	---	4	3VCC	---
5	3VCC	---	6	3VCC	---
7	GROUND	---	8	RES#	46

9	PG17 LCD_CL1_HSYNC	121	10	LCD_FLM_VSYNC PG16	123
11	PG19 LCD_CLK	176	12	GROUND	
13	GROUND		14	LCD0_B1 PG0	55
15	PG1 LCD1_B2	54	16	LCD2_B3 PG2	53
17	PG3 LCD3_B4	52	18	LCD4_B5 PG4	32
19	PG5 LCD5_G0	30	20	LCD6_G1 PG6	28
21	PG7 LCD7_G2	27	22	LCD8_G3 PG8	11
23	PG9 LCD9_G4	9	24	LCD10_G5 PG10	171
25	GROUND		26	LCD11_R1 PG11	169
27	PG12 LCD12_R2	155	28	LCD13_R3 PG13	154
29	PG14 LCD14_R4	151	30	LCD15_R5 PG15	150
31	GROUND		32	PG21/RSPCK1/TIOC0A	103
33	PG23/MOSI1/TIOC0C	---99	34	PG24/MISO1/TIOC0D	---97
35	PG22/SSL1/TIOC0B	---101	36	VCOM	---
37	-NC	---	38	GROUND	---
39	X-	---	40	Y-	
41	X+		42	Y+	
43	GROUND		44	VLED+	
45	VLED-				

Table 6-8: LCD Header CN11

6.10. SSI

The serial sound interface (SSI) is a module designed to send or receive audio data interface with various devices offering Sony/Philips Digital Interconnect Format (S/PDIF) compatibility. It also provides additional modes for other common formats, as well as support for multi-channel mode. Both transmitter and receiver modules are embedded. Audio Codec pins are available at header 'CN10'.

6.11. SD Card

SD card memory interface is provided in this controller.

Note: The SD card memory interface is not available in the RSP SH7267 default setting. To use the SD card memory interface, fit the following optional resistors: R286, R287, R288, R289, R290, R291, R26, R305, and R304; and remove the default resistors: R133, R134, R135, R136, R301, and R302.

Table 6-9 below details the SD Card header.

J1							
Pin	Header Name	Circuit Net Name	Device Pin	Pin	Header Name	Circuit Net Name	Device Pin
1	CD/DAT3	SD_D3	117	2	CMD	SD_CMD	116
3	VSS1	GROUND	---	4	VDD	3VCC_C	---
5	CLK	SD_CLK	115	6	VSS2	GROUND	---
7	DAT0	SD_D0	113	8	DAT1	SD_D1	111
9	DAT2	SD_D2	118	10	W_Protect	SD_WP	109
11	Card_Detect	SD_CD	108	12	COMMON	GROUND	---

Table 6-9: SD Card Header

6.12.Video Decoder

The video display controller provides video display function, video recording function, utility for overlaying graphics images on the input video, and function for outputting the control signals for the TFT-LCD panel.

Note: The video display controller is not available in the RSP SH7267 default setting. To use the video display controller, fit the following optional resistors: R69, R70, R71, R72, R73, R74, R75, R76, R80, R82, and R83; and remove the default resistors: R133, R134, R135, R136, R301, and R302.

Table 6-10 below details the Video Decoder header pin connections

CN10					
Pin	Circuit Net Name	Device Pin	Pin	Circuit Net Name	Device Pin
1	PE5/DV_HSYNC/SDA2	133	2	RES#	46
3	PE4/DV_VSYNC/SCL2	134	4	PE3/SDA1	135
5	PF0/DV_DATA0	119	6	PE2/SCL1	136
7	GROUND	---	8	3VCC	---
9	PF8/DV_CLK	108	10	PF4/DV_DATA4	115
11	PF1/DV_DATA1	118	12	PF5/DV_DATA5	113
13	PF2/DV_DATA2	117	14	PF6/DV_DATA6	111
15	PF3/DV_DATA3	116	16	PF7/DV_DATA7	109

Table 6-10: Video Decoder Header CN10

Table 6-11 below details the VGA connector pin connections

J9			
Header Pin	RSP board Signal Name	Header Pin	RSP board Signal Name
1	crt_red	2	crt_green
3	crt_blue	4	NC
5	GROUND	6	GROUND
7	GROUND	8	GROUND
9	NC	10	GROUND
11	NC	12	NC
13	LCD_CL1_HSYNC*	14	LCD_FLM_VSYNC*
15	NC		

Table 6-11: VGA Connector

* - These CPU pins are connected through a NAND gate

6.13. Option Links

In this section, the default configuration is indicated by **BOLD** text.

Table 6-12 describes the function of the option links associated with LCD configuration.

LCD interface Settings				
R209	LCD Interface	Connects Clock pin 26 of DAC to GROUND	Disconnects Clock pin 26 of DAC from GROUND	---
R210	LCD Interface	Connects signal R0 of Video DAC to ground	Disconnects signal R0 of Video DAC from ground	---
R212	LCD Interface	Connects signal R1 of Video DAC to ground	Disconnects signal R1 of Video DAC from ground	---
R213	LCD Interface	Connects signal R2 of Video DAC to ground	Disconnects signal R2 of Video DAC from ground	---
R211	LCD Interface	Connects signal R3 of Video DAC to PG11 (pin 169) of MCU	Disconnects signal R3 of Video DAC from PG11 (pin169) of MCU	---
R214	LCD Interface	Connects signal R4 of Video DAC to PG12 (pin 155) of MCU	Disconnects signal R4 of Video DAC from PG12 (pin155) of MCU	---
R215	LCD Interface	Connects signal R5 of Video DAC to PG13 (pin 154) of MCU	Disconnects signal R5 of Video DAC from PG13 (pin154) of MCU	---
R216	LCD Interface	Connects signal R6 of Video DAC to PG14 (pin 151) of MCU	Disconnects signal R6 of Video DAC from PG14 (pin151) of MCU	---
R217	LCD Interface	Connects signal R7 of Video DAC to PG15 (pin 150) of MCU	Disconnects signal R7 of Video DAC from PG15 (pin150) of MCU	---
R218	LCD Interface	Connects signal G0 of Video DAC to ground	Disconnects signal G0 of Video DAC from ground	---
R219	LCD Interface	Connects signal G1 of Video DAC to ground	Disconnects signal G1 of Video DAC from ground	---
R220	LCD Interface	Connects signal G2 of Video DAC to PG5 (pin30) of MCU	Disconnects signal G2 of Video DAC from PG5 (pin30) of MCU	---
R221	LCD Interface	Connects signal G3 of Video DAC to PG6 (pin28) of MCU	Disconnects signal G3 of Video DAC from PG6 (pin28) of MCU	---
R222	LCD Interface	Connects signal G4 of Video DAC to PG7 (pin27) of MCU	Disconnects signal G4 of Video DAC from PG7 (pin27) of MCU	---
R224	LCD Interface	Connects signal G5 of Video DAC to PG8 (pin11) of MCU	Disconnects signal G5 of Video DAC from PG8 (pin11) of MCU	---
R225	LCD Interface	Connects signal G6 of Video DAC to PG9 (pin 9) of MCU	Disconnects signal G6 of Video DAC from PG9 (pin9) of MCU	---
R226	LCD Interface	Connects signal G7 of Video DAC to PG10 (pin 171) of MCU	Disconnects signal G7 of Video DAC from PG10 (pin171) of MCU	---
R227	LCD Interface	Connects signal B0 of Video DAC to ground	Disconnects signal B0 of Video DAC from ground	---
R228	LCD Interface	Connects signal B1 of Video DAC to ground	Disconnects signal B1 of Video DAC from ground	---
R229	LCD Interface	Connects signal B2 of Video DAC to ground	Disconnects signal B2 of Video DAC from ground	---
R230	LCD Interface	Connects signal B3 of Video DAC to PG0 (pin55) of MCU	Disconnects signal B3 of Video DAC from PG0 (pin55) of MCU	---
R231	LCD Interface	Connects signal B4 of Video DAC to PG1 (pin54) of MCU	Disconnects signal B4 of Video DAC from PG1 (pin54) of MCU	---
R232	LCD Interface	Connects signal B5 of Video DAC to PG2 (pin53) of MCU	Disconnects signal B5 of Video DAC from PG2 (pin53) of MCU	---
R233	LCD Interface	Connects signal B6 of Video DAC to PG3 (pin52) of MCU	Disconnects signal B6 of Video DAC from PG3 (pin52) of MCU	---
R238	LCD Interface	Connects the BLANK pin of Video DAC to PG18 (pin2) of MCU	Disconnects the BLANK pin of Video DAC from PG18 (pin2) of MCU	---
R234	LCD Interface	Connects signal B7 of Video DAC to PG4 (pin32) of MCU	Disconnects signal B7 of Video DAC from PG4 (pin32) of MCU	---

R268	LCD Interface	Connects PJ2 pin of MCU to LCD_M_DISP pin of TFT LCD connector (JP12)	Disconnects PJ2 pin of MCU from LCD_M_DISP pin of TFT LCD connector (JP12)	R269, R275
------	---------------	---	---	------------

Table 6-12: LCD Configuration links

Table 6-13 describes the function of miscellaneous option links.

Option Link Settings				
Reference	Function	Fitted	Alternative (Removed)	Related To
R266	Touch Screen Configuration	Connects ADGTRG pin to 3VCC	Disconnects ADGTRG pin from 3VCC	R267, R236
R267	Touch Screen Configuration	Connects IRQ0 pin of the MCU to 3VCC	Disconnects IRQ0 pin of the MCU from 3VCC	R266, R236
R275	CAN Configuration	Connects PJ2 pin of MCU to CTX1 pin of voltage translator circuit in CAN module.	Disconnects PJ2 pin of MCU from CTX1 pin of voltage translator.	R268,R269 , R276
R276	CAN Configuration	Connects IRQ1 pin of MCU to CXR1 pin of voltage translator in CAN module.	Disconnects IRQ1 pin of MCU from CXR1 pin of voltage translator in CAN module.	R275
R277	CAN Configuration	Connects the CTX0 of MCU pin to pin 1 of HA13721 (CAN Intf.)	Disconnects the CTX0 of MCU pin from pin 1 of HA13721 (CAN Intf.)	---
R278	CAN Configuration	Connects the CRX0 of MCU pin to pin 3 of voltage translator in CAN circuit	Disconnects the CRX0 of MCU pin from pin 3 of voltage translator in CAN circuit	---
R53	Serial Flash Interface	Connects RESET pin of Serial Flash to 3VCC	Disconnects RESET pin of Serial Flash from 3VCC	R54
R54	Serial Flash Interface	Connects RESET pin of Serial Flash to the CPU reset pin	Disconnects RESET pin of Serial Flash from CPU reset pin	R53
R281	Serial Flash Interface	Connects the D pin of Serial Flash to pin 3 of J10 connector	Disconnects the D pin of Serial Flash from pin 3 of J10 connector	---
R282	Serial Flash Interface	Connects the Q pin of Serial Flash to pin 2 of J10 connector and MCU port pin PF2	Disconnects the Q pin of Serial Flash from pin 2 of J10 connector and MCU port pin PF2	---
R65	SDRAM Interface	Pull down resistor for CKE pin of the MCU	Disconnects CKE pin of MCU from the Pull down resistor	---
R32	NAND Flash Interface	Connects the WP pin of NAND flash memory to 3VCC	Disconnects the WP pin of NAND flash memory from 3VCC	---
R33	NOR Flash interface	Connects an external address line A25 of MCU to pin 56 of NOR Flash memory	Disconnects the address line A25 of MCU from pin 56 of Nor Flash memory	R37
R34	NOR Flash interface	Connects an external address line A24 of MCU to pin 1 of NOR Flash memory	Disconnects the address line A24 from pin 1 of Nor Flash memory	R38
R35	NOR Flash interface	Connects an external address line A23 of MCU to pin 2 of NOR Flash memory	Disconnects the address line A23 from pin 2 of Nor Flash memory	R39
R36	NOR Flash interface	Connects an external address line A22 to pin 15 of NOR Flash memory	Disconnects the address line A22 from pin 15 of NOR Flash memory	R40
R86	Video Decoder	Pull up resistor for the MCU pin CLKINV	Disconnects the pull up from CLKINV pin	R90
R90	Video Decoder	Connects CLKINV pin of Video Decoder to ground	Disconnects CLKINV pin of Video Decoder from ground	R86
R1	Power Supply	Connects 1.2VCC to PLL1.2V	Disconnects 1.2VCC from PLL1.2V	---
R252	Power Supply	Connects 1.2VCC to UA1.2V	Disconnects 1.2VCC from UA1.2V	---
R251	Power Supply	Connects 3VCC_CPU to UA3V	Disconnects 3VCC_CPU from UA3V	---
R250	Power Supply	Connects 3VCC_CPU to AVcc	Disconnects 3VCC_CPU from AVcc	---
R253	Oscillator	Connects X9 Crystal to EXTAL pin 57 of MCU	Disconnects crystal 'X9' from EXTAL pin 57 of MCU	---
R248	USB	Parallel resistor for inductor L1	Parallel resistor removed	---
R249	USB	Parallel resistor for inductor L3	Parallel resistor removed	---
R57	USB	Connects 5V supply to the Supply pin of power distribution switch MIC2025 (U7)	Disconnects 5V supply from the supply pin of U7	

R68	Video Decoder	Connects IIC bus address select (pin 73) of Video decoder to 3VCC	Disconnects IIC bus address select (pin 73) of Video decoder from pull up circuit.	R78
R78	Video Decoder	Connects IIC bus control pin 73 of Video decoder to ground	Disconnects IIC bus control pin 73 of Video decoder from ground	R68
R91	User Port	Connects the control input pin 1 of multiplexer to the RES pin of MCU	Disconnects the control input pin 1 of multiplexer from the RES pin of MCU	R280, R92
R140	Audio Interface	Connects Data input pin 17 of Audio driver to MCU port pin PE3 (pin135)	Disconnects Data input pin 17 of Audio driver from MCU port pin PE3 (pin135)	---
R141	Audio Interface	Connects clock input pin 16 of Audio driver to MCU port pin PE2 (pin136)	Disconnects clock input pin 16 of Audio driver from MCU port pin PE2 (pin 136)	---
R133	Audio Interface	Connects ADC and DAC sample rate clock pin 7 of audio driver to SSIWS1 (pin115) of MCU	Disconnects ADC and DAC sample rate clock pin 7 of audio driver from SSIWS1 (pin115) of MCU	---
R134	Audio Interface	Connects digital audio clock pin 8 of audio driver to SSISCK1 (pin116) of the MCU	Disconnects digital audio clock pin 8 of audio driver from SSISCK1 (pin 116) of the MCU	---
R135	Audio Interface	Connects ADC Data output (pin 9) of audio driver to SSIDATA1 (pin113) of the MCU	Disconnects ADC Data output (pin 9) of audio driver from SSIDATA1 (pin113) of the MCU	---
R136	Audio Interface	Connects DAC data input pin 10 of audio driver toSSIDATA2 (pin108) of the MCU	Disconnects DAC data input (pin 10) of audio driver from SSIDATA2 (pin 108) of the MCU	---
R143	Audio Interface	Connects chip select pin of audio driver to AUDIO_X1 (pin96) of the MCU	Disconnects chip select pin of audio driver from AUDIO_X1 (pin96) of the MCU	---
R139	Audio Interface	Connects the analog output pin 21 of audio driver to TP11 on board	Disconnects the analog output pin 21 of audio driver fromTP11 on board	---
R137	MIC	Connects the pin 1 of CN2 connector to ground	Disconnects the pin 1 of CN2 connector from ground	---
R146	Headphone	Connects the pin 4 of CN4 connector to GPIO2 pin of audio driver	Disconnects the pin 4 of CN4 connector from GPIO2 pin of audio driver	---
R293	Ethernet Configuration	Connects PB22 (pin 43) of MCU to Chip select pin of Ethernet	Disconnects PB22 (pin 43) of MCU from chip select pin of Ethernet	R268, R275
R283	Ethernet Configuration	Connects pin FIFO_SEL of LAN89218 to the external address pin A11 (pin22) of the MCU	Disconnects pin FIFO_SEL of LAN89218 from the address pin A11 (pin22) of the MCU	R179
R284	Ethernet Configuration	Connects the interrupt request pin of Ethernet controller to IRQ1 pin (port pin 137) of MCU	Disconnects the interrupt request pin of Ethernet controller from IRQ1 (pin137) of MCU	---
R265	Ethernet Configuration	Connects 'endianess select' pin of Ethernet controller to the address pin A19 (pin37) of MCU	Disconnects 'endianess select' pin of Ethernet controller from the address pin A19 (pin37) of MCU	---

Table 6-13: Miscellaneous Configuration links

6.14. Oscillator Sources

Oscillators are fitted on the CPU board and used to supply various clock inputs to the Renesas microcontroller. **Table 6-14** details the oscillators that are fitted and alternative footprints provided on this CPU board:

Component			
Oscillator (X1)	Not Fitted	25.175MHz	LCD Clock
Oscillator (X2)	Not Fitted	-	For Test Purposes
Crystal (X4)	Fitted	32.768KHz	Real Time Clock
Oscillator (X5)	Not Fitted	-	For Test Purposes
Crystal (X6)	Fitted	48 MHz	USB Clock
Oscillator (X7)	Fitted	24.576MHz	Video Decoder Clock
Crystal (X9)	Fitted	12MHz	System Clock
Oscillator (OSC1)	Fitted	13Mhz	External DAC/ADC Clock
Crystal (Y1)	Fitted	25MHz	Ethernet Clock

Table 6-14: Oscillators / Resonators

6.15. Reset Circuit

The CPU Board includes a Reset IC DS1819C (Q9) to meet the minimum reset period of 200 msec. The DS1819 monitor three vital conditions for a microprocessor: power supply, software execution, and external override. Please refer to the hardware manual for more information on the requirements of the reset circuit. Please check the reset requirements carefully to ensure the reset circuit on the user's board meets all the reset timing requirements.

Chapter 7. Modes

7.1. Boot modes

The boot modes supported by this RSP board are listed in. **Note:** Please ensure that SW1-6 is ON

Table 7-1

Boot Mode	SW1-2 (MD_BOOT1 pin)	SW1-3 (MD_BOOT0 pin)	Description
0	ON	ON	Boots the MCU, from the 4MB NOR flash memory (connected to the CS0 space)
1	ON	OFF	Boots the MCU, through high-speed communication, from the 4MB serial flash memory (connected to channel 0 of SPI interface)
2	OFF	ON	Boots the MCU from the 512 MB NAND flash memory (connected to the NAND flash memory controller interface)
3	OFF	OFF	Boots the MCU, through low-speed communication, from the 4MB serial flash memory (connected to channel 0 of SPI interface)

Note: Please ensure that SW1-6 is ON

Table 7-1: Boot Mode pin settings

The default boot mode of this RSP is indicated by **BOLD** text.

For more information on the boot modes listed above, please refer to the *SH7267 group hardware manual*.

7.2. Clock operating modes

This RSP supports following clock operating modes -

Mode		SW1-1 (MD_CLK pin)	Clock Source
0		ON	EXTAL or crystal resonator
1		OFF	USB_X1 or crystal resonator

Note: Please ensure that SW1-6 is ON

Table 7-2: Boot Mode pin settings

The default clock operating mode of this RSP is indicated by **BOLD** text.

For more information on the clock operating modes listed above, please refer to the *SH7267 group hardware manual*.

Chapter 8. Programming Methods

The board is intended for use with HEW and the supplied E10A debugger. Refer to *SH7267 Group Hardware Manual* for details of programming/ debugging without using these tools.

Chapter 9. Headers

9.1. Generic Headers

Table 9-1 to Table 9-2 below show the standard generic header connections.

Header Pin	CPU board Signal Name	Device pin	Header Pin	CPU board Signal Name	Device pin
1	5VCC	---	2	3VCC	---
3	A22	43	4	PD15	131
5	A21	39	6	PD14	132
7	A20	38	8	PD13	139
9	A19	37	10	PD12	140
11	A18	36	12	PD11	142
13	A17	35	14	PD10	144
15	A16	34	16	PD9	145
17	A15	26	18	PD8	146
19	GROUND	---	20	GROUND	---
21	A14	25	22	PD7	147
23	A13	24	24	PD6	148
25	A12	23	26	PD5	149
27	A11	22	28	PD4	156
29	A10	20	30	PD3	157
31	A9	18	32	PD2	158
33	A8	16	34	PD1	159
35	A7	15	36	PD0	160
37	GROUND	---	38	GROUND	---
39	A6	14	40	PC0/CS0#	161
41	A5	13	42	PC1/RD#	163
43	A4	8	44	PC2/RD/WR#	165
45	A3	7	46	PC3/WE0#/DQML	166
47	A2	6	48	PC4/WE1#/DQMU	167
49	A1	4	50	PC5B/RAS#	168
51	NC		52	PC6B/CAS#	173
53	NC		54	PC7B/CKE	174
55	NC		56	PC8B/CS3#	175

Table 9-1: JP15 microcontroller header

Header Pin	CPU board Signal Name	Device pin	Header Pin	CPU board Signal Name	Device pin
1	5VCC	---	2	3VCC	---
3	NC		4	PH0/AN0	80
5	NC		6	PH1/AN1	81
7	GROUND	---	8	PH2/AN2	82
9	NC		10	PH3/AN3	83
11	NC		12	GROUND	---
13	NC		14	TP_AN4	85
15	NC		16	TP_AN5	87
17	NC		18	NMI	44
19	NC		20	GROUND	---
21	NC		22	NC	
23	NC		24	PJ0/CTX0/IETXD	107
25	GROUND	---	26	PJ1/CRX0/IERXD	106
27	PG21/RSPCK1/TIOC0A	103	28	PG24/MISO1/TIOC0D	---97
29	PG22/SSL1/TIOC0B	101	30	NC	---
31	PG23/MOSI1/TIOC0C	99	32	GROUND	---

Table 9-2: JP16 microcontroller header

9.2. Generic TFT LCD Header

Generic TFT LCD header connections are detailed in Table 9-3.

JP12							
Header Pin	Generic TFT LCD Header Name	RSP board Signal Name	Device Pin	Header Pin	Generic TFT LCD Header Name	RSP board Signal Name	Device Pin
1	---	3VCC	---	2	---	3VCC	---
3	---	3VCC	---	4	LCD15_R5	PG15	150
5	LCD14_R4	PG14	151	6	LCD13_R3	PG13	154
7	LCD12_R2	PG12	155	8	LCD11_R1	PG11	169
9	LCD10_G5	PG10	171	10	LCD9_G4	PG9	9
11	LCD8_G3	PG8	11	12	LCD7_G2	PG7	27
13	LCD6_G1	PG6	28	14	LCD5_G0	PG5	30
15	LCD4_B5	PG4	32	16	LCD3_B4	PG3	52
17	LCD2_B3	PG2	53	18	LCD1_B2	PG1	54
19	LCD0_B1	PG0	55	20	---	GROUND	---
21	VLCD_CLK	NC	---	22	LCD_CL1_HSYNC	PG17	121
23	---	NC	---	24	---	NC	---
25	LCD_FLM_VSYNC	PG16	123	26	LCD_DISP	PG18	2
27	LCD_M_DISP	LCD_M_DISP	105	28	---	GROUND	---
29	---	GROUND	---	30	---	GROUND	---

Table 9-3: Generic TFT LCD Header

Generic SPDIF header connections are detailed in **Table 9-4**.

J10					
Header Pin	RSP board Signal Name	Device Pin	Header Pin	RSP board Signal Name	Device Pin
1	3VCC	---	2	SPDIF_OUT	124
3	SPDIF_IN	125	4	GROUND	---

Table 9-4: SPDIF Header

Chapter 10. Code Development

10.1. Overview

Note: For all code debugging using Renesas software tools, the CPU board must be connected to a PC USB port via an E10A. An E10A is supplied with the RSP product.

An E10A supplied with this Platform is an on-chip debugging emulator which supports the H-UDI interface of the target device. The H-UDI uses a 14-pin interface and marked as *E10A* on the RSPSH7267 board.

Due to the continuous process of improvements undertaken by Renesas the user is recommended to review the information provided on the Renesas website at www.renesas.com to check for the latest updates to the Compiler and Debugger manuals.

10.2. Compiler Restrictions

The compiler supplied with this RSP is fully functional for a period of 60 days from first use. After the first 60 days of use have expired, the compiler will default to a maximum of 256k code and data. To use the compiler with programs greater than this size you will need to purchase the full version tools from your Renesas distributor

Warning: The protection software for the compiler will detect changes to the system clock. Changes to the system clock back in time may cause the trial period to expire prematurely.

10.3. Breakpoint Support

Limited Event Conditions can be located in ROM code which is directly supported by E10A emulator. To enable breakpoints in RAM following command needs to be included in the script –

```
> SH2A_SBSTK enable
```

For more information on this, please refer to the *SuperH™ Family E10A-USB Emulator Additional Document for User's Manual* for SH7267.

10.4. Memory Map

The memory map shown in this section visually describes the memory areas of RSPSH7267.

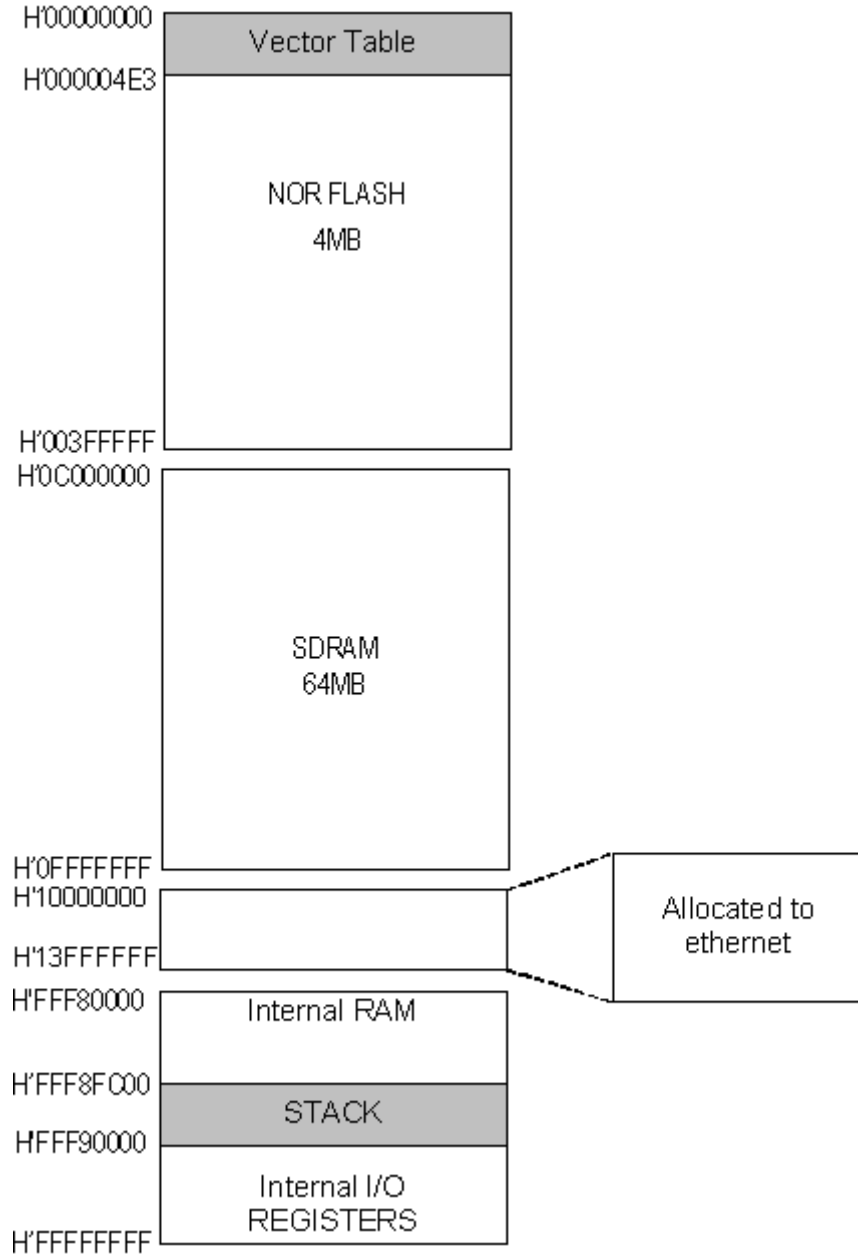

Figure 10-1: RSPSH7267 Memory Map

Chapter 11. Component Placement

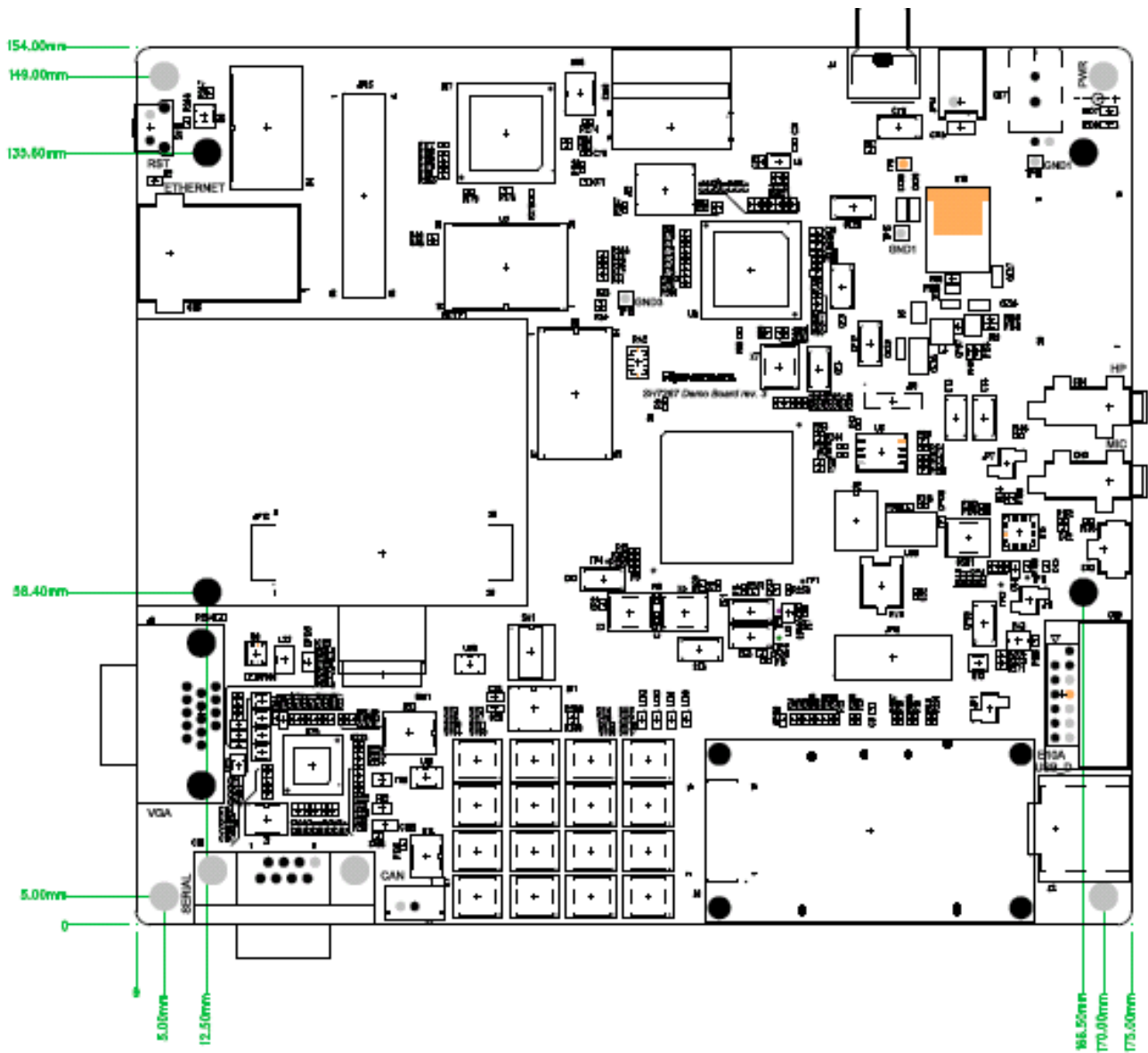

Figure 11-1: Component Placement (Top Layer)

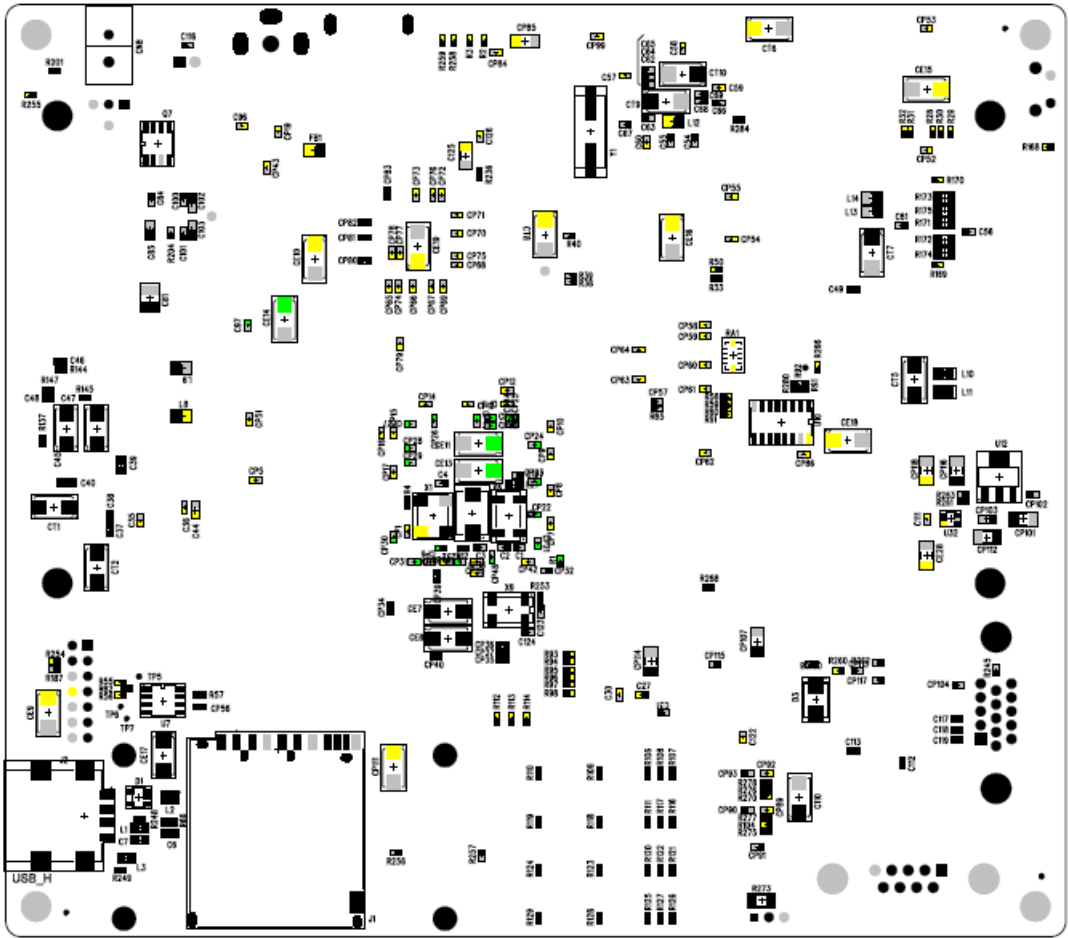

Figure 11-2: Component Placement (Bottom Layer)

Chapter 12. Additional Information

For details on how to use High-performance Embedded Workshop (HEW), refer to the HEW manual available on the CD or installed in the Manual Navigator.

For information about the SH7267 microcontrollers refer to the *SH7267 Group Hardware Manual*

For information about the SH7267 assembly language, refer to the *SH2A, SH2A-FPU Software Manual*

For information about the E10A Emulator, please refer to the *E10A-USB Emulator User's Manual*

Online technical support and information is available at: www.renesas.com/renesas_starter_Platforms

Technical Contact Details

America: techsupport.rta@renesas.com

Europe: tools.support.eu@renesas.com

Japan: csc@renesas.com

General information on Renesas Microcontrollers can be found on the Renesas website at: www.renesas.com

Renesas Starter Platform for SH7267
User's Manual
Publication Date Rev.1.00
Published by: Renesas Electronics America Inc

©2012 Renesas Electronics America, All Rights Reserved.

Renesas Starter Platform Plus for SH7267
User's Manual

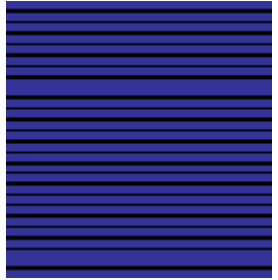

RENESAS

Renesas Electronics America Inc