

To our customers,

Old Company Name in Catalogs and Other Documents

On April 1st, 2010, NEC Electronics Corporation merged with Renesas Technology Corporation, and Renesas Electronics Corporation took over all the business of both companies. Therefore, although the old company name remains in this document, it is a valid Renesas Electronics document. We appreciate your understanding.

Renesas Electronics website: <http://www.renesas.com>

April 1st, 2010
Renesas Electronics Corporation

Issued by: Renesas Electronics Corporation (<http://www.renesas.com>)

Send any inquiries to <http://www.renesas.com/inquiry>.

Notice

1. All information included in this document is current as of the date this document is issued. Such information, however, is subject to change without any prior notice. Before purchasing or using any Renesas Electronics products listed herein, please confirm the latest product information with a Renesas Electronics sales office. Also, please pay regular and careful attention to additional and different information to be disclosed by Renesas Electronics such as that disclosed through our website.
2. Renesas Electronics does not assume any liability for infringement of patents, copyrights, or other intellectual property rights of third parties by or arising from the use of Renesas Electronics products or technical information described in this document. No license, express, implied or otherwise, is granted hereby under any patents, copyrights or other intellectual property rights of Renesas Electronics or others.
3. You should not alter, modify, copy, or otherwise misappropriate any Renesas Electronics product, whether in whole or in part.
4. Descriptions of circuits, software and other related information in this document are provided only to illustrate the operation of semiconductor products and application examples. You are fully responsible for the incorporation of these circuits, software, and information in the design of your equipment. Renesas Electronics assumes no responsibility for any losses incurred by you or third parties arising from the use of these circuits, software, or information.
5. When exporting the products or technology described in this document, you should comply with the applicable export control laws and regulations and follow the procedures required by such laws and regulations. You should not use Renesas Electronics products or the technology described in this document for any purpose relating to military applications or use by the military, including but not limited to the development of weapons of mass destruction. Renesas Electronics products and technology may not be used for or incorporated into any products or systems whose manufacture, use, or sale is prohibited under any applicable domestic or foreign laws or regulations.
6. Renesas Electronics has used reasonable care in preparing the information included in this document, but Renesas Electronics does not warrant that such information is error free. Renesas Electronics assumes no liability whatsoever for any damages incurred by you resulting from errors in or omissions from the information included herein.
7. Renesas Electronics products are classified according to the following three quality grades: “Standard”, “High Quality”, and “Specific”. The recommended applications for each Renesas Electronics product depends on the product’s quality grade, as indicated below. You must check the quality grade of each Renesas Electronics product before using it in a particular application. You may not use any Renesas Electronics product for any application categorized as “Specific” without the prior written consent of Renesas Electronics. Further, you may not use any Renesas Electronics product for any application for which it is not intended without the prior written consent of Renesas Electronics. Renesas Electronics shall not be in any way liable for any damages or losses incurred by you or third parties arising from the use of any Renesas Electronics product for an application categorized as “Specific” or for which the product is not intended where you have failed to obtain the prior written consent of Renesas Electronics. The quality grade of each Renesas Electronics product is “Standard” unless otherwise expressly specified in a Renesas Electronics data sheets or data books, etc.
 - “Standard”: Computers; office equipment; communications equipment; test and measurement equipment; audio and visual equipment; home electronic appliances; machine tools; personal electronic equipment; and industrial robots.
 - “High Quality”: Transportation equipment (automobiles, trains, ships, etc.); traffic control systems; anti-disaster systems; anti-crime systems; safety equipment; and medical equipment not specifically designed for life support.
 - “Specific”: Aircraft; aerospace equipment; submersible repeaters; nuclear reactor control systems; medical equipment or systems for life support (e.g. artificial life support devices or systems), surgical implantations, or healthcare intervention (e.g. excision, etc.), and any other applications or purposes that pose a direct threat to human life.
8. You should use the Renesas Electronics products described in this document within the range specified by Renesas Electronics, especially with respect to the maximum rating, operating supply voltage range, movement power voltage range, heat radiation characteristics, installation and other product characteristics. Renesas Electronics shall have no liability for malfunctions or damages arising out of the use of Renesas Electronics products beyond such specified ranges.
9. Although Renesas Electronics endeavors to improve the quality and reliability of its products, semiconductor products have specific characteristics such as the occurrence of failure at a certain rate and malfunctions under certain use conditions. Further, Renesas Electronics products are not subject to radiation resistance design. Please be sure to implement safety measures to guard them against the possibility of physical injury, and injury or damage caused by fire in the event of the failure of a Renesas Electronics product, such as safety design for hardware and software including but not limited to redundancy, fire control and malfunction prevention, appropriate treatment for aging degradation or any other appropriate measures. Because the evaluation of microcomputer software alone is very difficult, please evaluate the safety of the final products or system manufactured by you.
10. Please contact a Renesas Electronics sales office for details as to environmental matters such as the environmental compatibility of each Renesas Electronics product. Please use Renesas Electronics products in compliance with all applicable laws and regulations that regulate the inclusion or use of controlled substances, including without limitation, the EU RoHS Directive. Renesas Electronics assumes no liability for damages or losses occurring as a result of your noncompliance with applicable laws and regulations.
11. This document may not be reproduced or duplicated, in any form, in whole or in part, without prior written consent of Renesas Electronics.
12. Please contact a Renesas Electronics sales office if you have any questions regarding the information contained in this document or Renesas Electronics products, or if you have any other inquiries.

(Note 1) “Renesas Electronics” as used in this document means Renesas Electronics Corporation and also includes its majority-owned subsidiaries.

(Note 2) “Renesas Electronics product(s)” means any product developed or manufactured by or for Renesas Electronics.

M30803T-RPD-E

User's Manual

Emulation Pod for M16C/80 Group MCUs

* IC61-1004-051 is a product of Yamaichi Electronics Co., Ltd.

* NQPACK, YQPACK, YQSOCKET, YQ-Guide, HQPACK, TQPACK and TQSOCKET are products of Tokyo Eletech Corporation.

Keep safety first in your circuit designs!

- Renesas Technology Corporation and Renesas Solutions Corporation put the maximum effort into making semiconductor products better and more reliable, but there is always the possibility that trouble may occur with them. Trouble with semiconductors may lead to personal injury, fire or property damage. Remember to give due consideration to safety when making your circuit designs, with appropriate measures such as (i) placement of substitutive, auxiliary circuits, (ii) use of nonflammable material or (iii) prevention against any malfunction or mishap.

Notes regarding these materials

- These materials are intended as a reference to assist our customers in the selection of the Renesas Technology product best suited to the customer's application; they do not convey any license under any intellectual property rights, or any other rights, belonging to Renesas Technology Corporation, Renesas Solutions Corporation or a third party.
- Renesas Technology Corporation and Renesas Solutions Corporation assume no responsibility for any damage, or infringement of any third-party's rights, originating in the use of any product data, diagrams, charts, programs, algorithms, or circuit application examples contained in these materials.
- All information contained in these materials, including product data, diagrams, charts, programs and algorithms represents information on products at the time of publication of these materials, and are subject to change by Renesas Technology Corporation and Renesas Solutions Corporation without notice due to product improvements or other reasons. It is therefore recommended that customers contact Renesas Technology Corporation, Renesas Solutions Corporation or an authorized Renesas Technology product distributor for the latest product information before purchasing a product listed herein. The information described here may contain technical inaccuracies or typographical errors. Renesas Technology Corporation and Renesas Solutions Corporation assume no responsibility for any damage, liability, or other loss arising from these inaccuracies or errors. Please also pay attention to information published by Renesas Technology Corporation and Renesas Solutions Corporation by various means, including the Renesas home page (<http://www.renesas.com>).
- When using any or all of the information contained in these materials, including product data, diagrams, charts, programs, and algorithms, please be sure to evaluate all information as a total system before making a final decision on the applicability of the information and products. Renesas Technology Corporation and Renesas Solutions Corporation assume no responsibility for any damage, liability or other loss resulting from the information contained herein.
- Renesas Technology semiconductors are not designed or manufactured for use in a device or system that is used under circumstances in which human life is potentially at stake. Please contact Renesas Technology Corporation, Renesas Solutions Corporation or an authorized Renesas Technology product distributor when considering the use of a product contained herein for any specific purposes, such as apparatus or systems for transportation, vehicular, medical, aerospace, nuclear, or undersea repeater use.
- The prior written approval of Renesas Technology Corporation and Renesas Solutions Corporation is necessary to reprint or reproduce in whole or in part these materials.
- If these products or technologies are subject to the Japanese export control restrictions, they must be exported under a license from the Japanese government and cannot be imported into a country other than the approved destination. Any diversion or reexport contrary to the export control laws and regulations of Japan and/or the country of destination is prohibited.
- Please contact Renesas Technology Corporation or Renesas Solutions Corporation for further details on these materials or the products contained therein.

Precautions to be taken when using this product

- This product is a development supporting unit for use in your program development and evaluation stages. In mass-producing your program you have finished developing, be sure to make a judgment on your own risk that it can be put to practical use by performing integration test, evaluation, or some experiment else.
- In no event shall Renesas Solutions Corporation be liable for any consequence arising from the use of this product.
- Renesas Solutions Corporation strives to cope with the issues given below at some charge or without charge.
 - (1) Repairing or replacing a flawed product. There can be instances in which a product cannot be repaired if more than one year have passed since the discontinuance of its marketing.
 - (2) Renovating or providing a workaround for product malfunction. This does not necessarily mean that Renesas Solutions Corporation guarantees the renovation or the provision under any circumstances.
- This product has been developed by assuming its use for program development and evaluation in laboratories. Therefore, it does not fall under the application of Electrical Appliance and Material Safety Law and protection against electromagnetic interference when used in Japan.
- Do not attempt to modify this equipment. If modified, your authority to operate this equipment might be voided by FCC.
Note: This equipment has been tested and found to comply with the limits for a Class A digital device, pursuant to part 15 of the FCC Rules. These limits are designed to provide reasonable protection against harmful interference when the equipment is operated in a commercial environment. This equipment generates, uses, and can radiate radio frequency energy and, if not installed and used in accordance with the instruction manual, may cause harmful interference to radio communications. Operation of this equipment in a residential area is likely to cause harmful interference in which case the user will be required to correct the interference at his own expense.
Warning: This is a Class A product. In a domestic environment this product may cause radio interference in which case the user may be required to take adequate measures.

For inquiries about the contents of this document or product, fill in the text file the installer of the emulator debugger generates in the following directory and email to your local distributor.

\\SUPPORT\Product-name\SUPPORT.TXT

Renesas Tools Homepage <http://www.renesas.com/en/tools>

Preface

The M30803T-RPD-E is an emulation pod for the M16C/80 Group of Renesas 16-bit MCUs. It's used with a PC4701 emulator.

This user's manual mainly describes specifications of the M30803T-RPD-E emulation pod and how to setup it. For details on the following products, which are used with M30803T-RPD-E, refer to each product's user's manual.

- Emulator: PC4701 User's Manual
- Emulator debugger: M3T-PD308 User's Manual

All the components of this product are shown in "Table 2.1 Package components" (page 19) of this user's manual. If there is any question or doubt about this product, contact your local distributor.

To use the product properly

Precautions for Safety



- In both this user's manual and on the product itself, several icons are used to insure proper handling of this product and also to prevent injuries to you or other persons, or damage to your properties.
- The icons' graphic images and meanings are given in "Chapter 1. Precautions for Safety". Be sure to read this chapter before using the product.

When using outside Japan



- When using in Europe, the United States, or Canada, be sure to use both the emulator and the emulation pod which meet local standards. EMI standards are not met when the M30803T-RPD-E is used with the PC4700H or PC4700L emulator.

Contents

Chapter 1. Precautions for Safety	7
1.1 Safety Symbols and Meanings	8
Chapter 2. Preparation	17
2.1 Terminology	18
2.2 Package Components	19
2.3 Other Tool Products Required for Development	19
2.4 Name of Each Part	20
(1) System Configuration	20
(2) Inside of Emulation Pod	21
2.5 When Using the Emulator for the First Time	22
Chapter 3. Setting Up	23
3.1 Removing the Upper Cover	24
3.2 Switch Settings	25
3.3 Selecting Clock Supply	29
(1) Using the Oscillator Circuit on the Target System	30
(2) Changing the Internal Oscillator Circuit of Emulation Pod	31
(3) Replacing the Oscillator Circuit Boards	32
3.4 A-D Conversion Bypass Capacitor	33
3.5 Connecting the PC4701 and Emulation Pod	34
(1) Connecting the Cable to the PC4701	34
(2) Connecting the Cable to the Emulation Pod	35
3.6 Connecting the Target System	36
(1) Connecting 100-pin LCC Socket	37
(2) Connecting 100-pin 0.65-mm-pitch Foot Pattern (Part 1)	38
(3) Connecting 100-pin 0.65-mm-pitch Foot Pattern (Part 2)	39
(4) Connecting 100-pin 0.65-mm-pitch Foot Pattern (Part 3)	40
(5) Connecting 100-pin 0.5-mm-pitch Foot Pattern (Part 1)	41
(6) Connecting 100-pin 0.5-mm-pitch Foot Pattern (Part 2)	42
(7) Connecting 144-pin 0.5-mm-pitch Foot Pattern	43
Chapter 4. Usage	45
4.1 Turning On the Power Supply	46
(1) Checking the Connection of the System	46
(2) Turning On the Power Supply	46
(3) LED Display When PC4701 Starts Up Normally	47
4.2 Downloading Firmware	48
(1) When It is Necessary to Download Firmware	48
(2) Downloading Firmware in Maintenance Mode	48
4.3 Starting Up the Emulator Debugger (Setting EMEM Dialog)	49
(1) Setting the Debug Monitor Bank Address	49
(2) Selecting the Processor Mode	50
(3) Setting the Emulation Memory	50
(4) Emulation Memory Allocation as Expansion Area	50
(5) Referring MCU STATUS	52

4.4 Self-check	53
(1) Self-check Procedure	53
(2) If an Error is Detected in the Self-check	53
Chapter 5. Specifications	55
5.1 Specifications	56
5.2 Connection Diagram	57
5.3 Operation Timing in Memory Expansion Mode and Microprocessor Mode	59
(1) Timing Requirements	59
5.4 Electrical Characteristics	59
5.5 External Dimensions	60
(1) External Dimensions of Emulation Pod	60
(2) External Dimensions of Converter Board (M30800T-PTC)	61
(3) External Dimensions of Converter Board (FLX-144NSD)	62
Chapter 6. Troubleshooting	63
6.1 Flowchart to Remedy the Troubles	64
6.2 When the Emulator Debugger Does Not Start Up Properly	65
(1) When the LED Display of PC4701 is Abnormal	65
(2) EMEM Dialog is Not Displayed When the Emulator Debugger Starts Up (When the target system is connected)	66
(3) EMEM Dialog is Not Displayed When the Emulator Debugger Starts Up (When the target system is not connected)	67
(4) Errors Occur When the Emulator Debugger Starts Up (When the target system is connected)	67
6.3 Operation Differs from That of Actual MCUs	67
(1) When the A-D Conversion Values are Different from Expected Values	67
Chapter 7. Maintenance and Guarantee	69
7.1 Maintenance	70
7.2 Guarantee	70
7.3 Repair Provisions	70
7.4 How to Request for Repair	71

MEMO

Chapter 1. Precautions for Safety

This chapter describes precautions for using this product safely and properly. For precautions for the emulator main unit and the emulator debugger, refer to each user's manual included with your product.



1.1 Safety Symbols and Meanings	8
WARNING Warning for Installation	9
Warnings for Use Environment	9
CAUTION Caution to Be Taken for Modifying This Product	9
Cautions to Be Taken for Handling This Product	9
IMPORTANT Note on Malfunctions in the PC4701 System	9
Notes on Downloading Firmware	10
Note on When the Emulator Debugger Ends	10
Note on Final Evaluation	10
Notes on Target System	10
Note on RESET* Input	10
Note on RDY* Input	11
Note on HOLD* Input	11
Note on NMI* Input	11
Notes on Interruption	11
Note on Clock Supply to the MCU	11
Notes on Access Prohibited Area	11
Notes on Stack Area	12
Notes on Reset Vector Area	12
Note on Debugging MCUs with RAM over 24 KB	12
Note on Debugging M16C/80T Group MCUs	12
Notes on EMEM Dialog	13
Note on S/W Break	13
Note on Differences between Actual MCU and Emulator	14
Notes on Watchdog Function	14
Notes on A-D Input Selection Function	15
Note on DMA Transfer	15
Note on Address Match Interrupt	15
Note on Protect Resistor	15

Chapter 1. Precautions for Safety

In both the user's manual and on the product itself, several icons are used to insure proper handling of this product and also to prevent injuries to you or other persons, or damage to your properties.

This chapter describes the precautions which should be taken in order to use this product safely and properly. Be sure to read this chapter before using this product.

1.1 Safety Symbols and Meanings

	WARNING	If the requirements shown in the "WARNING" sentences are ignored, the equipment may cause serious personal injury or death.
	CAUTION	If the requirements shown in the "CAUTION" sentences are ignored, the equipment may malfunction.
	IMPORTANT	It means important information on using this product.

In addition to the three above, the following are also used as appropriate.

△ means WARNING or CAUTION.
Example:  **CAUTION AGAINST AN ELECTRIC SHOCK**

⊘ means PROHIBITION.
Example:  **DISASSEMBLY PROHIBITED**

● means A FORCIBLE ACTION.
Example:  **UNPLUG THE POWER CABLE FROM THE RECEPTACLE.**

The following pages describe the symbols "WARNING", "CAUTION", and "IMPORTANT".

WARNING

Warning for Installation:



- Do not set this product in water or areas of high humidity. Make sure that the main unit does not get wet. Spilling water or some other liquid into the main unit can cause an unrepairable damage.

Warnings for Use Environment:



- The emulation pod is air-cooled with the ventilation slot. Therefore, do not block the ventilation slot. When heated to high temperatures, the emulation pod may not work properly.
- This equipment is to be used in an environment with a maximum ambient temperature of 35°C. Care should be taken that this temperature is not exceeded.

CAUTION

Caution to Be Taken for Modifying This Product:



- Do not disassemble or modify this product. Disassembling or modifying this product can cause damage. Disassembling and modifying the product will void your warranty.

Cautions to Be Taken for Handling This Product:



- Use caution when handling the main unit. Be careful not to apply a mechanical shock.
- Do not touch the connector pins of the emulator main unit and the target MCU connector pins. Static electricity may damage the internal circuits.
- Do not pull the emulation pod main unit by the flexible cable (FLX120-RPD) for connecting to the emulator main unit or the flexible cable (FLX64, FLX100 or FLX160) for connecting the target system. The cable may cause a break.
- Flexible cable (FLX120-RPD) for connecting to the emulator main unit and the flexible cable (FLX64, FLX100 or FLX160) for connecting the target system are different from earlier models. The slits make them more flexible. However, excessive flexing or force may break conductors.
- Do not use inch-size screws for this equipment. The screws used in this equipment are all ISO (meter-size) type screws. When replacing screws, use same type screws as equipped before.

IMPORTANT

Note on Malfunctions in the PC4701 System:

- If the emulator malfunctions because of interference like external noise, do the following to remedy the trouble.
 - (1) Press the RESET button on the emulator front panel.
 - (2) If normal operation is not restored after step (1), shut OFF power to the emulator once and then reactivate it.

IMPORTANT

Notes on Downloading Firmware:

- Before using this product for the first time, it is necessary to download the dedicated firmware (control software for the emulation pod built into the PC4701). Please note that, to do this, it is necessary to start up the PC4701 in maintenance mode. For firmware download procedures, see "4.2 Downloading Firmware" (page 48). Once the firmware has been downloaded, the product can be used by simply turning on the power.
- Do not shut off the power while downloading the firmware. If this happens, the product will not start up properly. If power is shut off unexpectedly, redownload the firmware.
- Except when a target status error occurs, if the self-check is not completed successfully, there may be trouble with the product. In such case, contact your sales representative. However, perform the self-check in the below setup.

- (1) Target system: Not connected
- (2) Emulation pod internal switches: At their factory settings

Note on When the Emulator Debugger Ends:

- To restart the emulator debugger after it ends, always shut power to the emulator module off once and then on again.

Note on Final Evaluation:

- Be sure to evaluate your system with an evaluation MCU. Before starting mask production, evaluate your system and make final confirmation with an CS (Commercial Sample) version MCU.

Notes on Target System:

- The Vcc pin of emulator is connected to the target system to observe the voltage of the target system. Therefore design your system so that the emulator MCU is powered by the target system.
- The voltage of the target system should be within the range of the MCU specification (+2.7 to +5.5 V). When using this product with the operating frequency at 20 MHz, the voltage of the target system should be +5.0 to +5.5 V.
- Do not change the voltage of the target system after turning on the power.
- Before powering on your emulator system, check that the host machine, the emulator main unit, the converter board and target system are all connected correctly. Next, turn on the power to each equipment following the procedure below.
 - (1) Turn ON/OFF the target system and the PC4701 emulator as simultaneously as possible.
 - (2) When the PC4701 and emulator debugger start up, check the target status LEDs on the emulator main unit's front panel to see if this product is ready to operate.
 - Is the power supplied? Check that target status LED (POWER) is ON.
 - Is the reset released? Check that target status LED (RESET) is OFF.

Note on RESET* Input:

- The reset input from the target system is accepted only while a user program is being executed (only while the RUN status LED on the PC4701's front panel is lit).

IMPORTANT

Note on RDY* Input:

- Be sure to input "L" to the RDY* pin of the target system during the user program executing (only while the RUN status LED on the PC4701's front panel is lit). Inputting "L" to the RDY* pin during the user program stopping may cause a malfunction of the emulator.

Note on HOLD* Input:

- Be sure to input "L" to the HOLD* pin of the target system during the user program executing (only while the RUN status LED on the PC4701's front panel is lit). Inputting "L" to the HOLD* pin during the user program stopping may cause a malfunction of the emulator.

Note on NMI* Input:

- NMI* input from the target system is accepted only while a user program is being executed (only while the RUN status LED on the PC4701's front panel is lit).

Notes on Interruption:

- Even while the user program is not being executed (when the user program is paused or while debug programs are running), the evaluation MCU is operating for controlling debug programs. Therefore, take note that timers and other functions are not stopped while the user program is not being executed.
- When a maskable interrupt is generated in user program execution (when the user program is paused or while debug programs are running), the interrupt cannot be accepted, because the emulator disables interrupts. If an interrupt is requested while a user program is not being executed and the user program allow the interrupt, the interrupt is accepted immediately after the user program execution is started.

Note on Clock Supply to the MCU:

- Clock can be supplied to the evaluation MCU in one of the following two ways. This is determined by emulator debugger clock selection.
 - (1) When Internal is selected:

The clock generated by the oscillation circuit in the emulation pod is supplied to the evaluation MCU. The clock is continually supplied to the evaluation MCU regardless of "target system clock status" and "user program execution status".
 - (2) When External is selected:

Clock supply to the evaluation MCU depends on oscillation status (oscillate/off) of the target system.

Notes on Access Prohibited Area:

- The emulator control register (000020h - 00003Fh) in the SFR is read and write-protected. When this register is accessed, emulator control cannot be utilized.
- With this product, address FFFFFFFh cannot be read or written in correctly.

IMPORTANT

Notes on Stack Area:

- With this product, a maximum 20 bytes of the user stack is consumed as work area.
- If the user stack does not have enough area, do not use areas which cannot be used as stack (SFR area, RAM area which stores data, or ROM area) as work area. Using areas like this is a cause of user program crashes and destabilized emulator control. Therefore, ensure the +20 byte maximum capacity used by the user program as the user stack area.
- With this product, the interrupt stack pointer (ISP) is set to 0500h and used as stack area after the reset is released.

Notes on Reset Vector Area:

- For a reset vector area, memory of the emulation pod is always selected regardless of the setting of EMEM dialog. Therefore when setting the microprocessor mode, to use a ROM of the target system etc. as an area including a reset vector area, set a reset vector using a dump window etc.
- The reset vector area can be changed only when a program is stopped. When a program is executed, the area can not be changed.

Note on Debugging MCUs with RAM over 24 KB:

- This product has an MCU with 24 KB of RAM. Therefore, it cannot debug MCUs with more than 24 KB of RAM. Also, internally reserved areas (006400h - 007FFFh) cannot be used.

Note on Debugging M16C/80T Group MCUs:

- With this product, the M16C/80T Group MCUs cannot be debugged. Prepare the emulation pod for the M16C/80T Group MCUs.

IMPORTANT

Notes on EMEM Dialog:

Observe the following when setting up EMEM dialog of the emulator debugger.

(1) Debug Monitor Bank Address

- When "F0" is specified, 64 KB of area starting from F00000h are allocated for use by the debug monitor.
- The 64 KB allocated to the debug monitor cannot be used.
- The below areas cannot be set for the debug monitor.

- (1) MCU internal resources (RAM/SFR area)
- (2) DRAM area or multiplex area
- (3) Interrupt vector area

- It is not possible to view or set the content of the specified area. Even on the dump window or in the reverse assemble area of the program/source windows, the content of this area is not displayed correctly though it can be displayed.

(2) Processor Mode

- Set the target MCU to the processor mode.
- To set the single-chip mode and memory expansion mode, the CNVSS pin used with MCU status must be "L". MCU status indicates pin level of the target system.
- To set the microprocessor mode, the CNVSS pin used with MCU status must be "H".
- To set the memory expansion mode and microprocessor mode, the RDY* and HOLD* pins used with MCU status must be "H".

(3) Emulation Memory Allocation

- The 1.5MB memory mounted in the product can be allocated out.
- When the single chip mode and memory expansion mode are set by specifying the processor mode, emulation memory is automatically allocated to the ROM area. Therefore, it is not necessary to deliberately specify emulation memory as expansion area in order to allocated ROM area.
- Except for the SFR, RAM, ROM and internally reserved areas, all areas other than the set area are externally accessible.
- MCU internal resources are automatically selected as SFR and RAM areas regardless of settings.
- Even when "00" is specified as the expansion area, internally reserved areas (006400h - 007FFFh) cannot be used.
- Be careful that the specified areas do not overlap one another.
- Set memory allocation so that the total of the 4 length values does not exceed the emulation memory size (1.5 MB).
- Do not set unusable areas for memory allocation.
- Emulation pod memory is automatically selected as reset vector area regardless of settings.

Note on S/W Break:

- S/W breaks generate break interruptions by forcibly inserting a BRK instruction "08h" instead of a instruction code. Therefore, when referencing the result of a trace in bus mode, "08h" is displayed for the instruction fetch address where a S/W break is set.

IMPORTANT

Note on Differences between Actual MCU and Emulator:

- Operations of the emulator differs from those of mask MCUs as listed below.

- (1) Reset condition
- (2) Initial values of internal resource data at power-on
- (3) Interrupt stack pointer (ISP) after releasing reset
- (4) Internal memories (ROM and RAM) capacities, etc.

This emulator system has an MCU with 24KB RAM (0400h - 63FFh). In single-chip mode or memory expansion mode, emulation memory for internal ROM is automatically allocated in the area between FC0000h through FFFFFFFh, and it can be read and written into.

- (5) Oscillator circuit

- Make note of the fact that in the oscillator circuit where a resonator is connected between the X_{IN} and X_{OUT} pins, oscillation does not occur because a flexible cable, buffer IC and other devices are used between the evaluation MCU and the target system. It is same for sub-clock oscillators (X_{CIN} and X_{COUT}).
- For notes on when using the oscillator circuit on the target system, refer to "3.3 (1) Using the Oscillator Circuit on the Target System" (page 30).

- (6) A-D conversion

As a flexible cable, a pitch converter board and other devices are used between the evaluation MCU and the target system, some characteristics are slightly different from those of the actual MCU. Perform final evaluations of the A-D converter with the actual MCU.

- (7) Port P10

As a part of I/O port (P10) is connected to the target system through the analog switch circuit, electric characteristics slightly differ from those of actual MCU.

- (8) Voltage

When using this product with the operating frequency at 20 MHz, the voltage of the target system should be +5.0 to +5.5 V.

Notes on Watchdog Function:

- The MCU's watchdog timer can be used only while programs are being executed. To use it otherwise, disable the watchdog timer. And take note that when the following two conditions are satisfied, programs can not be executed.
 - (1) The watchdog timer function selection bit (CM06) of the system clock control register 0 is set to "1".
 - (2) The HOLD function is used while the watchdog timer is operating.
- If the reset circuit of the target system has a watchdog timer, disable it when using the emulator.

IMPORTANT

Notes on A-D Input Selection Function:

- To use A-D input group selection, it is necessary to set the direction register of port P10 to input. Port 10 corresponds to the pin that performs A-D conversion.

Example: To select A-D input for P00-P07, set the direction register of P100-P107 and P00-P07 to input.

Also, when the port P0 group and port P2 group are selected for A-D input, port P10 cannot be used as an I/O port.

- Because a flexible board and other elements exist between the evaluation MCU and target system, the A-D converter operates differently than the actual MCU. Perform final evaluations of the A-D converter with the actual MCU.

Note on DMA Transfer:

- With this product, the program is stopped with a loop program to a specific address. Therefore, if a DMA request is generated by a timer or other source while the program is stopped, DMA transfer is executed. However, make note of the fact that DMA transfer while the program is stopped may not be performed correctly. Also note that the below registers have been changed to generate DMA transfer as explained here even when the program is stopped.

DMA2 transfer counter register DCT2 (R0)
DMA3 transfer counter register DCT3 (R1)
DMA2 memory address register DMA2 (A0)
DMA3 memory address register DMA3 (A1)

Note on Address Match Interrupt:

- To debug with the address match interrupt, set the S/W and H/W breaks in the top address used in address match interrupt processing.

Note on Protect Resistor:

- Make note of the fact that the protect is not canceled when protect register 3 (PRC2), which enables writing in the port P9 direction register and the pin output function select register, is changed with the below procedure.

- (1) Step execution of the "instruction for setting ("1") PRC2"
- (2) Setting the break point from the "instruction for setting ("1") PRC2" to when the "port P9 direction register or pin output function select register 3 is set"
- (3) Setting "("1") PRC2" from the dump window or script window during user program execution

MEMO

Chapter 2. Preparation

This chapter describes the package components, the system configuration and the preparation for using this product for the first time.

2.1 Terminology	18
2.2 Package Components	19
2.3 Other Tool Products Required for Development	19
2.4 Name of Each Part	20
(1) System Configuration	20
(2) Inside of Emulation Pod	21
2.5 When Using the Emulator for the First Time	22

Chapter 2. Preparation

2.1 Terminology

Some specific words used in this user's manual are defined as follows:

Emulator system

This means an emulator system built around the PC4701 emulator. The PC4701 emulator system is configured with an emulator main unit, emulation pod, host machine and emulator debugger.

Emulator main unit (Hereafter PC4701)

This means a generic name for emulators for 8 and 16-bit MCUs. For details on specific models of PC4701, visit Renesas Tools Homepage.

Homepage URL <http://www.renesas.com/en/tools>

Emulation pod

This means the M30803T-RPD-E (this product). This emulation pod is for M16C/80 Group MCUs.

Host machine

This means a personal computer used to control the emulator and emulation pod.

Emulator debugger

This means a software tool M3T-PD308 to control the emulator from the host machine through an interface.

Firmware

Program that analyzes contents of communication with the emulator debugger and controls the emulator hardware. This program is installed in the EEPROM. This program is downloadable from the emulator debugger to upgrade the firmware or to support other MCUs.

Software break

A software break is a function to break the program before the system executes an instruction at the specified address. The instruction at the preset address will not be executed.

Hardware break

A hardware break is a function to break the program when the system detects a write/read of data to/from memory or a rise/fall edge of the signal entered from the external trace cable. The former break function is called address break; and the latter break function is called trigger break. While the instruction at the address where the software break is set is not executed, a hardware break is performed after the specified instruction is executed.

Evaluation MCU

This means the microcomputer mounted on the emulation pod which is operated in the specific mode for tools.

Target MCU

This means the microcomputer you are going to debug.

Target system

This means a user's application system using the microcomputer to be debugged.

*

In this user's manual, this symbol is used to show active LOW. (e.g. RESET*: Reset signal)

2.2 Package Components

The M30803T-RPD-E package consists of the following items. When unpacking, check to see if your M30803T-RPD-E contains all of these items.

Table 2.1 Package components

Item	Quantity
M30803T-RPD-E emulation pod main unit	1
FLX120-RPD flexible cable for connecting emulator main unit	1
FLX160-PRB converter board for connecting FLX160 to M30800T-PTC (mounted on FLX160)	1
M30800T-PTC converter board for 100-pin LCC package	1
OSC-2 oscillator circuit board (bare-board)	1
Hardware tool user registration FAX sheet (English)	1
Hardware tool user registration FAX sheet (Japanese)	1
M30803T-RPD-E user's manual (this manual)	1
M30803T-RPD-E user's manual (Japanese)	1

Please keep the M30803T-RPD-E's packing box and cushion material in your place for reuse at a later time when sending your product for repair or other purposes. Always use these packing box and cushion material when transporting M30803T-RPD-E.

If any of these items are missing or found faulty, please contact your local distributor. Also, if there is any question or doubt about the packaged product, contact your local distributor.

2.3 Other Tool Products Required for Development

To bring forward programs development on the M16C/80 Group MCUs, the products listed below are necessary in addition to those contained package above. Get them separately.

Table 2.2 Other tool products

Product	Product name	Notes	
Emulator main unit	PC4701	Required	
Emulator debugger	M3T-PD308	Required	
Converter boards	144-pin 0.5-mm-pitch LQFP (144P6Q-A)	Required according to the foot pattern of the target system (see 3.6 "Connecting the Target System" on page 36)	
	100-pin 0.5-mm-pitch LQFP (100P6Q-A)		FLX-144NSD
			100LCC-QSD 100LCC-DMS + FLX-100NSD
	100-pin 0.65-mm-pitch QFP (100P6S-A)		100LCC-DMS + DUMMY100S
			100LCC-DMS + DIRECT100S
			100LCC-DMS + FLX-100NRB
100-pin LCC socket	IC51-1004-051 etc.		

* To purchase these products, contact your nearest distributor.

* For details on the IC51-1004-51, contact Yamaichi Electronics Co., Ltd.

2.4 Name of Each Part

(1) System Configuration

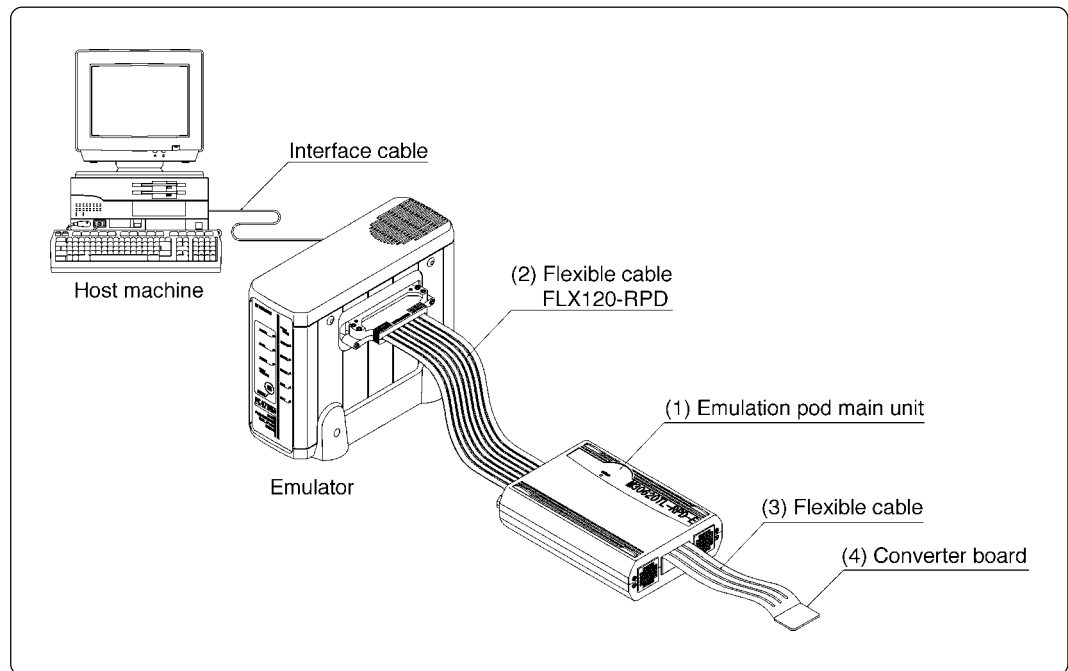

Figure 2.1 System configuration

(1) to (4) in Figure 2.1 are included in this product package.

(1) Emulation pod (M30803T-RPD-E)

This emulation pod contains an evaluation MCU, emulation memory and circuit to feature the debugging function.

(2) Flexible cable (FLX120-RPD)

This 120-pin flexible cable connects the PC4701 emulator and the emulation pod.

(3) Flexible cable (FLX160)

This 160-pin flexible cable connects the emulation pod and the target system.

(4) Converter board

This is a converter board for connecting to the target system.
For details, refer to "3.6 Connecting the Target System" (page 36).

(2) Inside of Emulation Pod

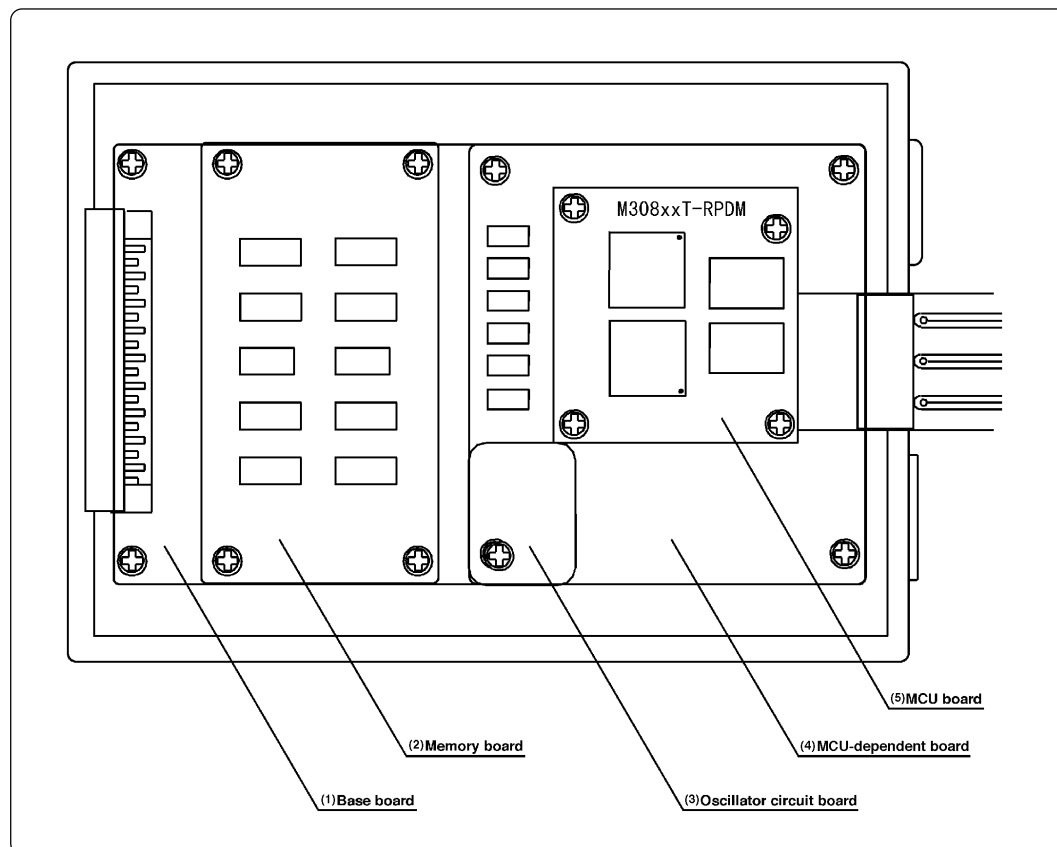

Figure 2.2 Internal view of emulation pod

(1) Base board

Base board for the M16C/80 Group MCUs which controls the interface with the PC4701 and the evaluation MCU.

(2) Memory board

Board on which the 1.5MB emulation memory is mounted.

(3) Oscillation circuit board

Board on which the internal oscillation circuit of the emulation pod is mounted. Operating frequency can be changed by replacing this board with other available oscillation circuit boards.

(4) MCU-dependent board

Board grouping parts (number of pins or added functions) which vary according to MCU model.

(5) MCU board

Board on which the MCU and the emulation memory for the MCU's internal ROM are mounted.

It is planned to enable customers to use future M16C/80 Group models (Max. 20 MHz applicable frequency) by changing the MCU-dependent board and MCU board.

2.5 When Using the Emulator for the First Time

If you have purchased this emulation pod newly, it is necessary to download the firmware. The download procedure is given in Figure 2.3.

Before attempting to download the firmware, check the emulator debugger is installed and the emulator is connected to the host machine. For more information, see each user's manual of the emulator debugger and the PC4701.

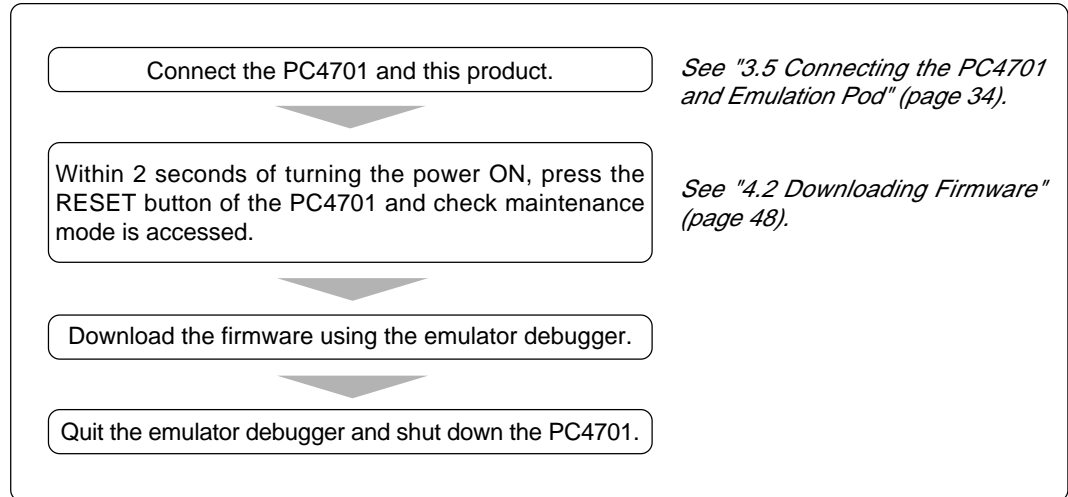

Figure 2.3 Firmware download procedure when emulator is used for the first time

To make sure the emulation pod works properly, run the self-check. For self-check procedures, see "4.4 Self-check" (page 53).

Chapter 3. Setting Up

This chapter describes switch settings required for using this product and how to connect this product to the PC4701 and the target system.

3.1 Removing the Upper Cover	24
3.2 Switch Settings	25
3.3 Selecting Clock Supply	29
(1) Using the Oscillator Circuit on the Target System	30
(2) Changing the Internal Oscillator Circuit of Emulation Pod	31
(3) Replacing the Oscillator Circuit Boards	32
3.4 A-D Conversion Bypass Capacitor	33
3.5 Connecting the PC4701 and Emulation Pod	34
(1) Connecting the Cable to the PC4701	34
(2) Connecting the Cable to the Emulation Pod	35
3.6 Connecting the Target System.....	36
(1) Connecting 100-pin LCC Socket	37
(2) Connecting 100-pin 0.65-mm-pitch Foot Pattern (Part 1)	38
(3) Connecting 100-pin 0.65-mm-pitch Foot Pattern (Part 2)	39
(4) Connecting 100-pin 0.65-mm-pitch Foot Pattern (Part 3)	40
(5) Connecting 100-pin 0.5-mm-pitch Foot Pattern (Part 1)	41
(6) Connecting 100-pin 0.5-mm-pitch Foot Pattern (Part 2)	42
(7) Connecting 144-pin 0.5-mm-pitch Foot Pattern	43

Chapter 3. Setting Up

To use this emulation pod with your application system, it is necessary to set as follows. Set the following after removing the upper cover.

- Change the oscillation frequency.
- Set the X_{CIN} and X_{COUT} pins for the target system.
- Set the signals such as HOLD/RDY to control the external device.
- Install the A-D conversion bypass capacitor.

3.1 Removing the Upper Cover

The procedure of removing the upper cover is shown below.

- (1) Remove the four screws of both sides of this product and lift off the upper cover (see Figure 3.1).
- (2) Set the jumper switches.
- (3) Replace the upper cover and secure the four screws.

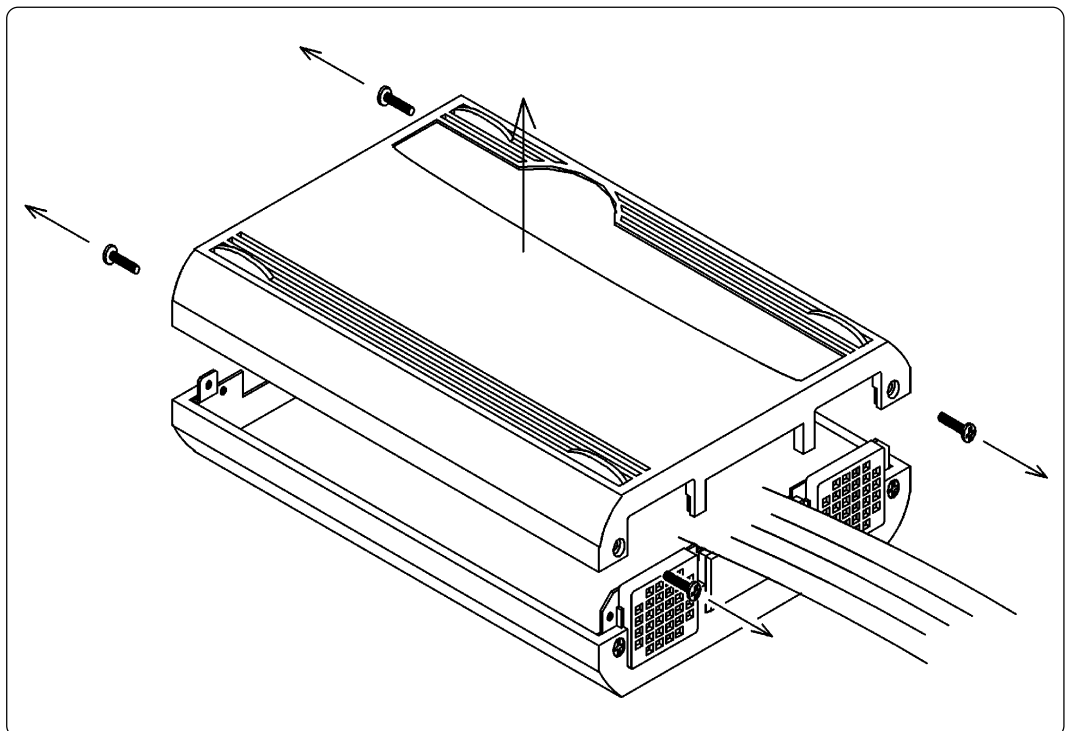

Figure 3.1 Removing the upper cover

CAUTION

When Removing the Upper Cover:

- Always shut OFF power when removing the upper cover or setting the switches.
- Do not touch the connector pins of the emulator main unit and the target MCU connector pins. Static electricity may damage the internal circuits.

3.2 Switch Settings

Figure 3.2 shows the positions of switches and Tables 3.1, 3.2 and 3.3 show each switch setting.

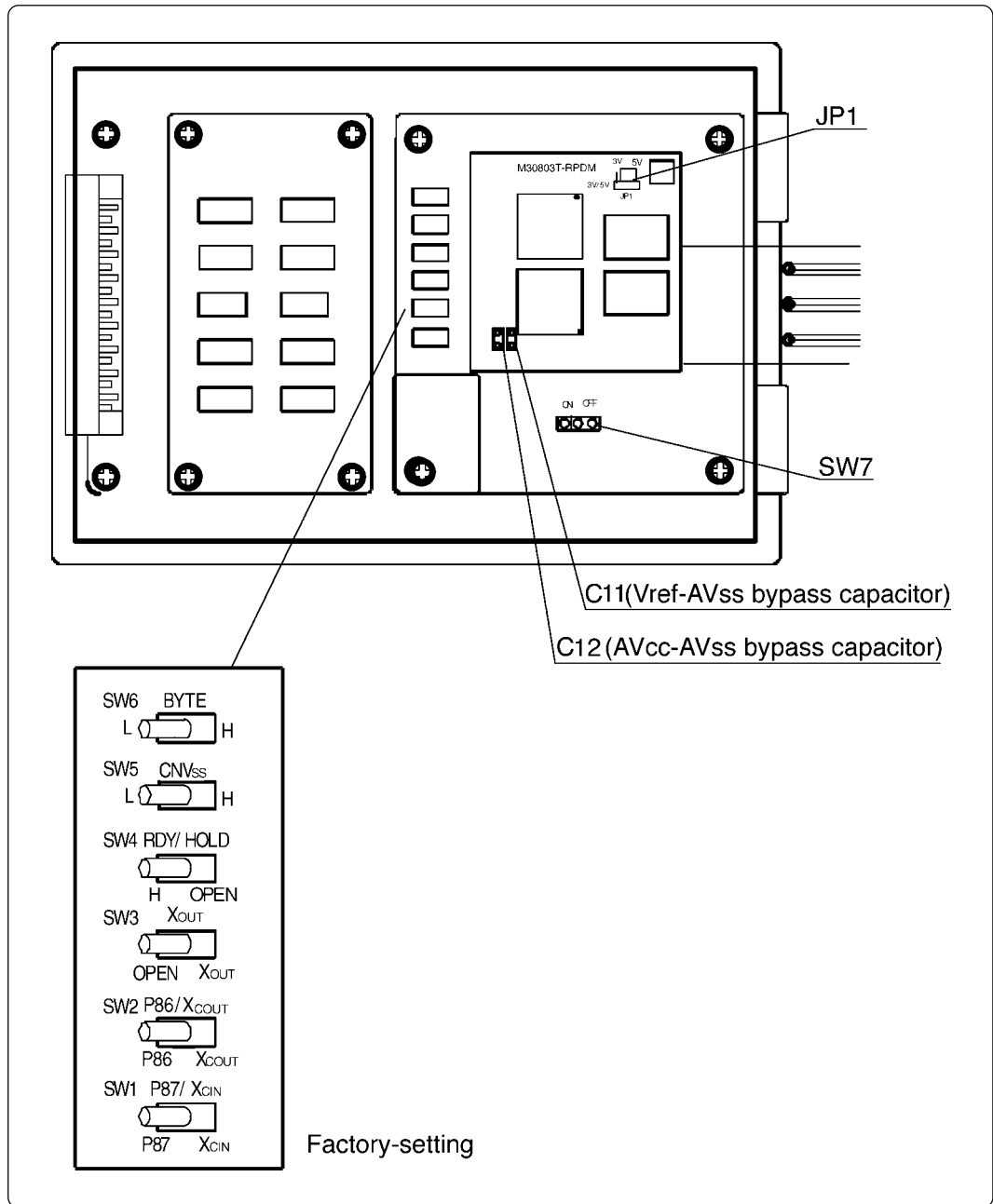

Figure 3.2 Positions of switches and their factory-settings

Table 3.1 Switch settings of the M30803T-RPD-E (1/3)

Signal	Switch	Setting	Description
P87/X _{CIN} P86/X _{COU} T	SW1	 P87 X _{CIN} SW1 (Factory-setting)	Connects the P87/X _{CIN} pin of MCU to the target system (uses the P87/X _{CIN} pin as Port P87).
		 P87 X _{CIN} SW1	Connects the P87/X _{CIN} pin of MCU to the sub-clock oscillator circuit (32.768 kHz) on the emulation pod.
	SW2	 P86 X _{COU} SW2 (Factory-setting)	Connects the P86/X _{COU} T pin of MCU to the target system (uses the P86/X _{COU} T pin as Port P86).
		 P86 X _{COU} SW2	P86/X _{COU} T pin of MCU is unconnected.
		 P86 X _{COU} SW2	Connects the P86/X _{COU} T pin of MCU to the target system (uses the P86/X _{COU} T pin as X _{COU} T).
	X _{OU} T	SW3	 OPEN X _{OU} T SW3 (Factory-setting)
 OPEN X _{OU} T SW3			Connects the X _{OU} T pin of MCU to the target system.
RDY*/ HOLD*	SW4	 H OPEN SW4 RDY/HOLD (Factory-setting)	Pulls up the RDY* and HOLD* pins of MCU with a resistance of 33 kΩ. Be sure to set this when using the emulation pod while not connecting the target system.
		 H OPEN SW4 RDY/HOLD	Connects the RDY* and HOLD* pins of MCU to the target system.

Table 3.2 Switch settings of the M30803T-RPD-E (2/3)



Signal	Switch	Setting	Description
CNV _{SS}	SW5		Pulls down the CNV _{SS} pin with a resistance of 33 k Ω (when target system is unconnected and using in single-chip mode or memory expansion mode). Be sure to set this when using the emulation pod while not connecting the target system.
			Connects the CNV _{SS} pin to the target system.
			Pulls up the CNV _{SS} pin with a resistance of 33 k Ω (when target system is unconnected and using in microprocessor mode). Be sure to set this when using the emulation pod while not connecting the target system.
BYTE	SW6		Pulls down the BYTE pin with a resistance of 33 k Ω (when target system is unconnected and using in 16-bit bus mode). Be sure to set this when using the emulation pod while not connecting the target system.
			Connects the BYTE pin to the target system.
			Pulls up the BYTE pin with a resistance of 33 k Ω (when target system is unconnected and using in 8-bit bus mode). Be sure to set this when using the emulation pod while not connecting the target system.
A-D input Select group	SW7		Set when not using the A-D input group selection function. Use this product with this setting.
			Set when using the A-D input group selection function. This product cannot be used with this setting.

Table 3.3 Switch settings of the M30803T-RPD-E (3/3)

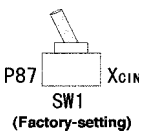
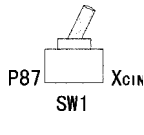
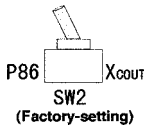
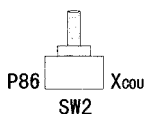
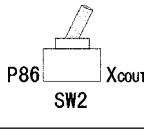
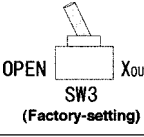
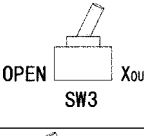
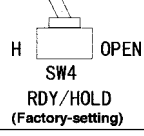
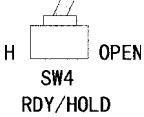
Signal	Switch	Setting	Description
Voltage	JP1 M30803T-RPDM Board	3V 5V JP1  (Factory-setting)	Set when using at the range of the voltage within +4.2 to +5.5 V.
		3V 5V JP1 	Set when using at the range of the voltage within +2.7 to +4.2 V.

IMPORTANT

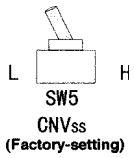
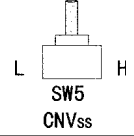
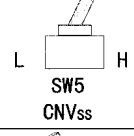
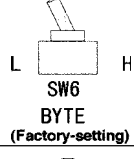
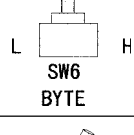
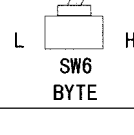
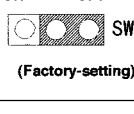
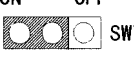
Note on Switch Setting:

- Switch settings of RDY*/HOLD*, CNV_{ss} and BYTE are provided to enable debugging without connecting to the target system. When using the emulator debugger in connection with the target system, set SW4 to the OPEN position and SW5 and SW6 to the center position.

Note on Using A-D Input Group Selection:

- It is necessary to set the direction register of port P10 to input. Port P10 corresponds to the pin that performs A-D conversion.

Example: To select A-D input for P00-P07, set the direction registers of P100-P107 and P00-P07 to input. Also, when the port P0 group and port P2 group are selected for A-D input, port P10 cannot be used as an I/O port.

3.3 Selecting Clock Supply

There are two ways to supply a clock to the MCU, using the oscillator circuit of the emulation pod or using the oscillator circuit on the target system. Table 3.4 shows the factory-settings of each clock supply.

Table 3.4 Clock supply to the MCU

Clock	Description	Display of emulator debugger	Factory-setting
X _{IN} -X _{OUT}	Internal oscillator circuit of emulation pod (OSC-3: 20 MHz)	Internal	Yes
	Target system	External	-
X _{CIN} -X _{COU}	Internal oscillator circuit of emulation pod (32.768 KHz)	Internal	-
	Target system	External	Yes

IMPORTANT

Notes on Changing the Clock Supply:

- The clock supply can be set by the Init dialog when starting up the emulator debugger or inputting CLK command on the script window.
- For X_{CIN}-X_{COU} pins, it is necessary to set switches in the emulation pod when using the clock on the target system. For details, refer to "3.2 Switch Settings" (page 25).

(1) Using the Oscillator Circuit on the Target System

When turning on the power supply, the internal clock of emulation pod is selected to supply the clock to the MCU. To use the external clock on the target system, change the clock by the CLK command or the Init dialog on the emulator debugger. (For details, refer to the user's manual of the emulator debugger.)

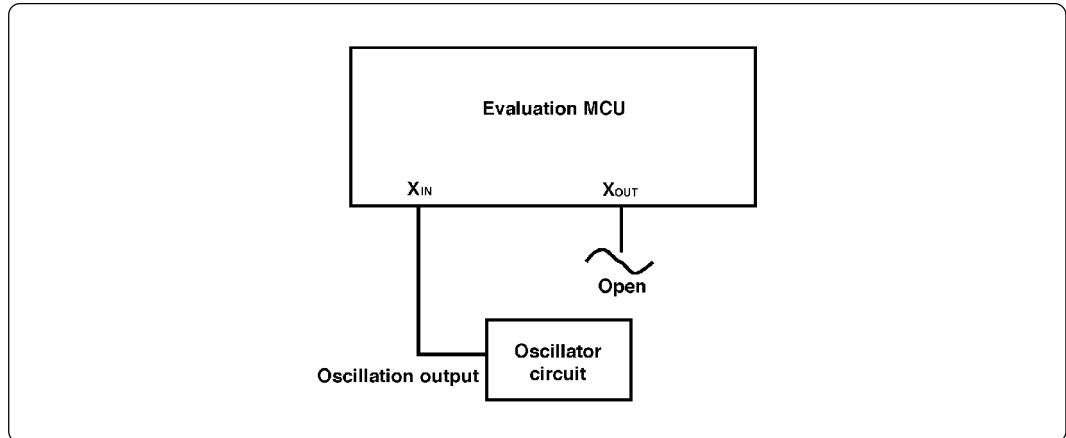

Figure 3.3 External oscillator circuit

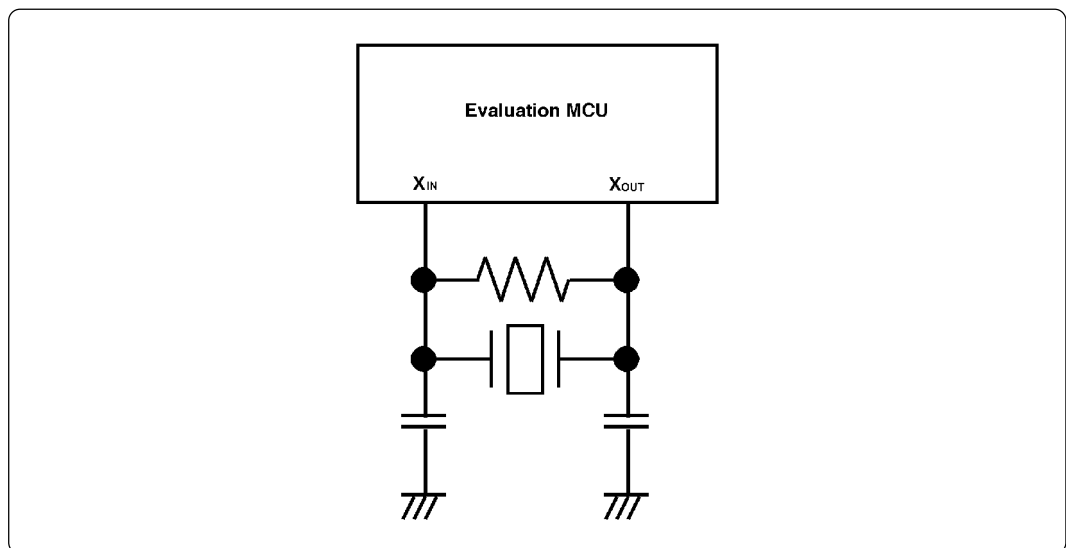

Figure 3.4 Circuit in which oscillation does not occur (same for X_{CIN}-X_{COUT})

IMPORTANT

Notes on External Clock:

- To operate the emulation pod with an external clock, construct the oscillator circuit as shown in Figure 3.3 in the target system and input the oscillator output at 50% duty (within the operating range of the evaluation MCU) into the X_{IN} pin. And the X_{OUT} pin should be open.
- Make note of the fact that in the oscillator circuit shown in Figure 3.4 where a resonator is connected between the X_{IN} and X_{OUT} pins, oscillation does not occur because a flexible cable, buffer IC and other devices are used between the evaluation MCU and the target system. It is same for sub-clock oscillator circuits (X_{CIN} and X_{COUT}).

(2) Changing the Internal Oscillator Circuit of Emulation Pod

An oscillator circuit board (OSC-3) for 20 MHz is mounted on this product. To use the emulation pod at a frequency other than 20 MHz, build the desired oscillator circuit on the included OSC-2 oscillator circuit board (bare board) and replace the board installed in the emulation pod when shipped from the factory.

Figure 3.5 shows a view of the OSC-2 oscillator circuit board (bare board) and where connector pins are located. Figure 3.6 shows the circuitry of the OSC-2 oscillator circuit board (bare board). Use the number of oscillator circuits recommended by the oscillator manufacturer.

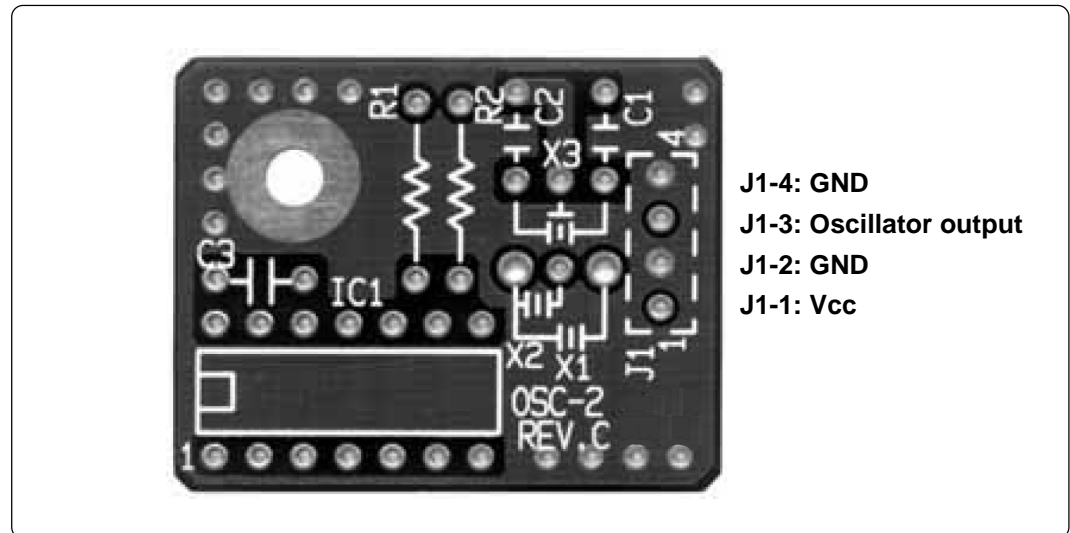

Figure 3.5 External view of oscillator board (OSC-2) and connector pin assignment

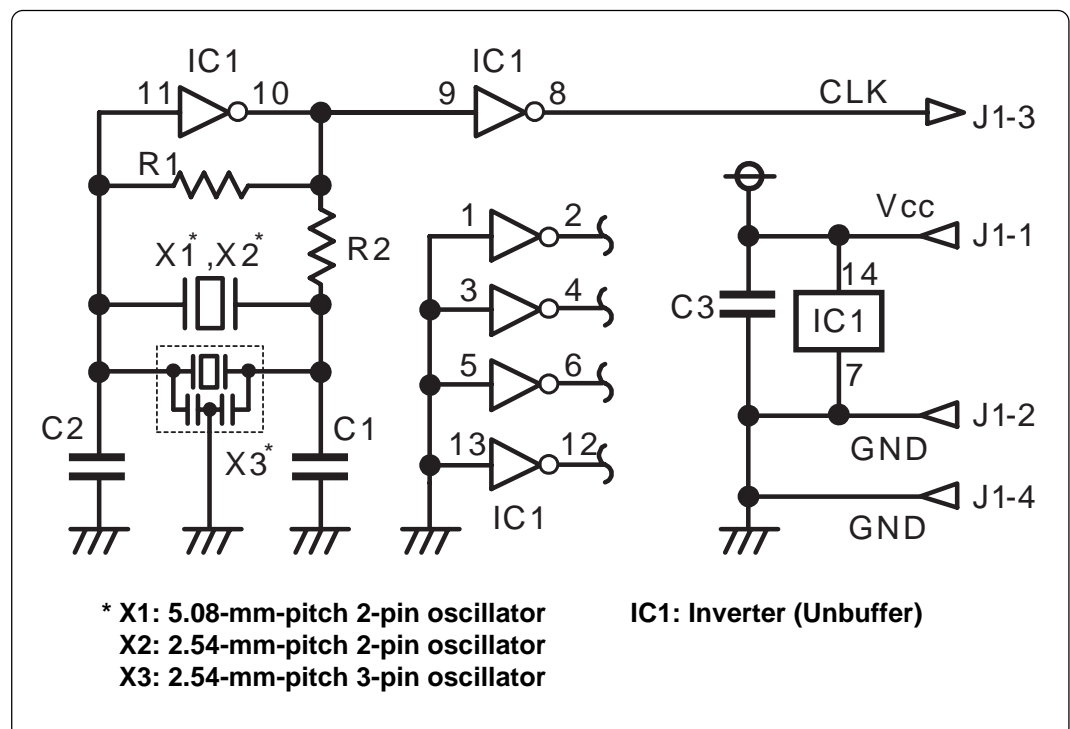

Figure 3.6 Circuit of oscillator board (OSC-2)

(3) Replacing the Oscillator Circuit Boards

Figure 3.7 shows how to replace the oscillator circuit boards. For the position of the oscillator circuit board, see Figure 2.2.

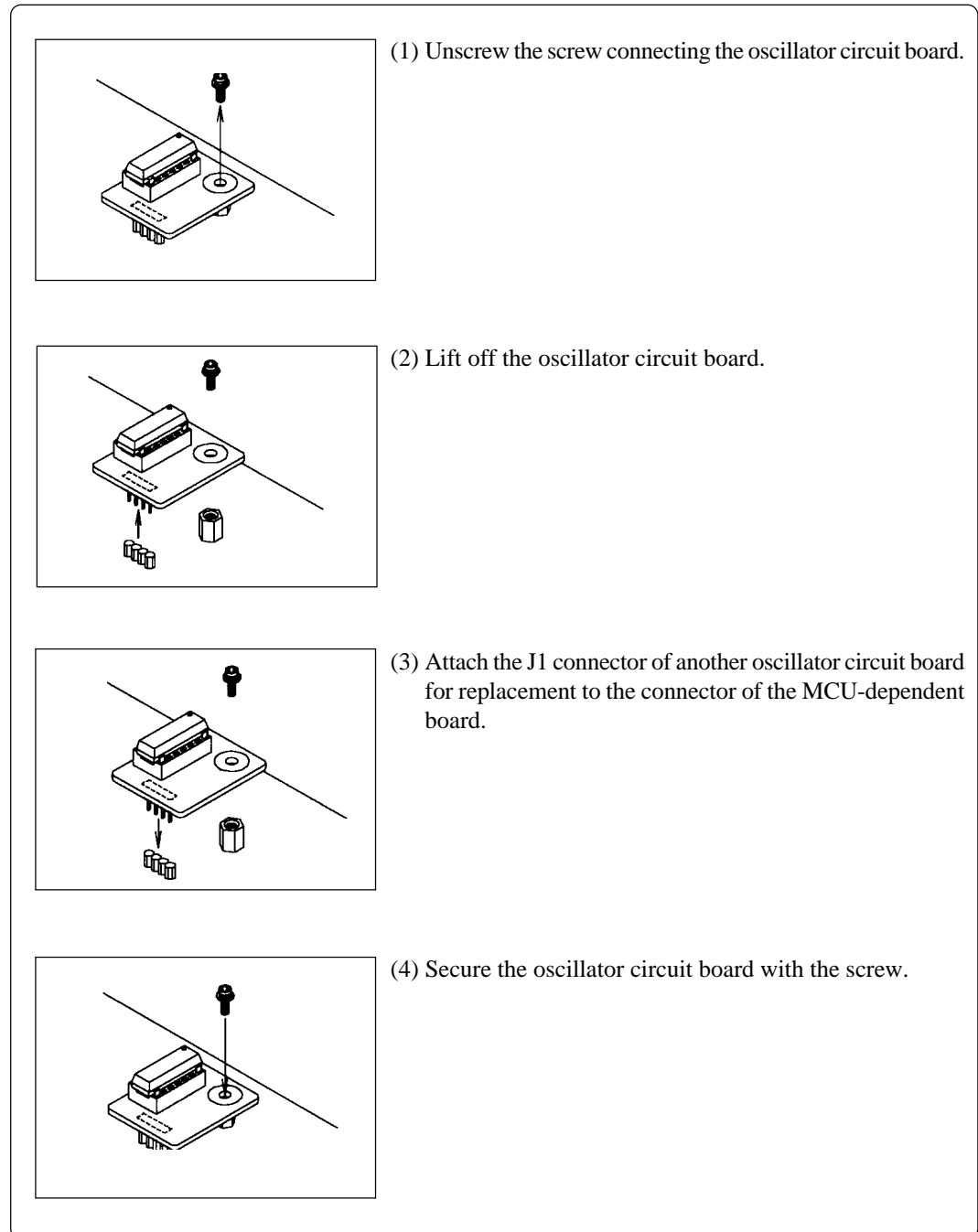

Figure 3.7 Replacing the oscillator circuit boards

3.4 A-D Conversion Bypass Capacitor

The emulation pod has foot patterns on the board for mounting a bypass capacitor. Mount a suitable bypass capacitor as occasion demands.

Figure 3.2 shows where the bypass capacitors are mounted, whereas Figure 3.8 shows an enlargement of the foot patterns.

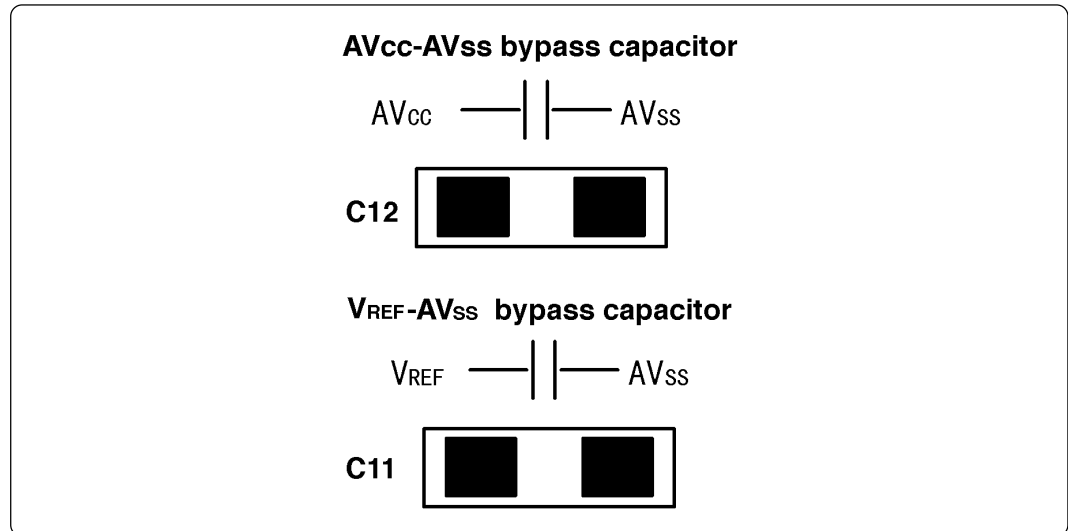

Figure 3.8 Foot patterns of A-D conversion bypass capacitor

IMPORTANT

Note on the A-D Converter:

- Because a flexible board and other devices are used between the evaluation MCU and the target system, the A-D converter operates differently from the actual MCU. Make the final evaluation of the A-D converter from the actual MCU.

3.5 Connecting the PC4701 and Emulation Pod

To connect the emulation pod to the PC4701, use the FLX120-RPD 120-pin flexible cable included in this product package. Connect the PC4701 side connector of FLX120-RPD to the cable connector of the PC4701, then secure with screws.

(1) Connecting the Cable to the PC4701

Figure 3.9 shows how to connect the PC4701 and FLX120-RPD.

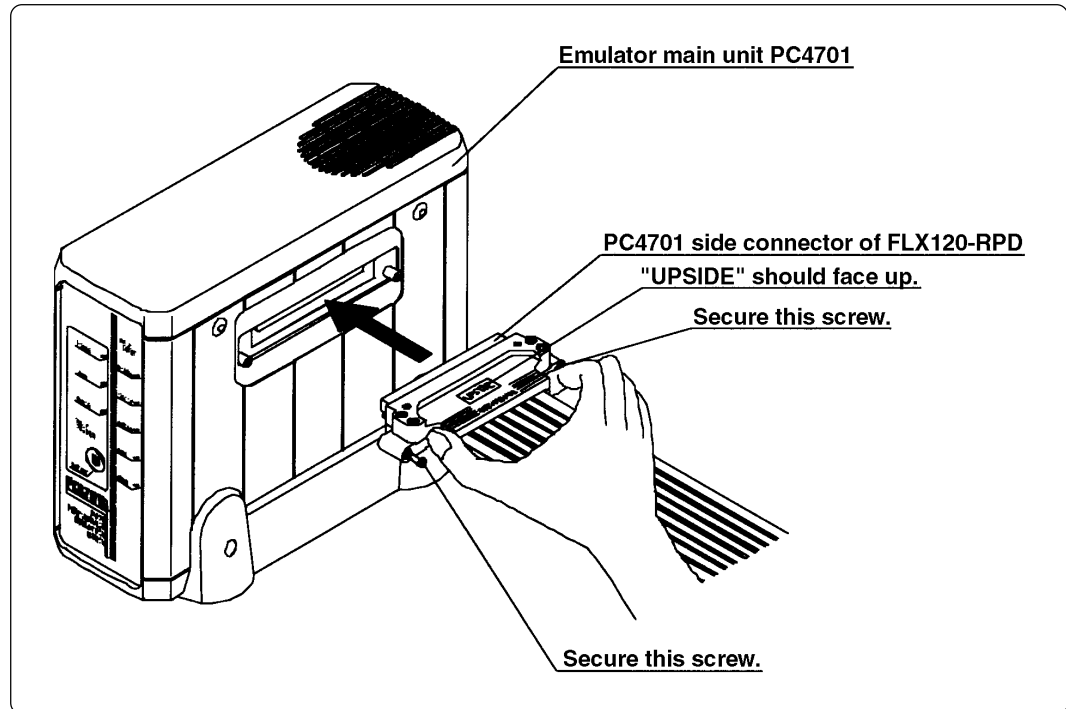

Figure 3.9 Connecting PC4701 and FLX120-RPD

CAUTION

Note on Connecting the Cable:

- Always shut OFF power before connecting the cable. The power ON state could destroy internal circuits.
- To connect the FLX120-RPD, be sure to hold the both sides of the PC4701 side connector horizontally with the "UPSIDE" facing up.

Note on Securing the Screws:

- After connecting the emulator main unit to the cable, be sure to secure the screws.

(2) Connecting the Cable to the Emulation Pod

Figure 3.10 shows how to connect the FLX120-RPD and the emulation pod.

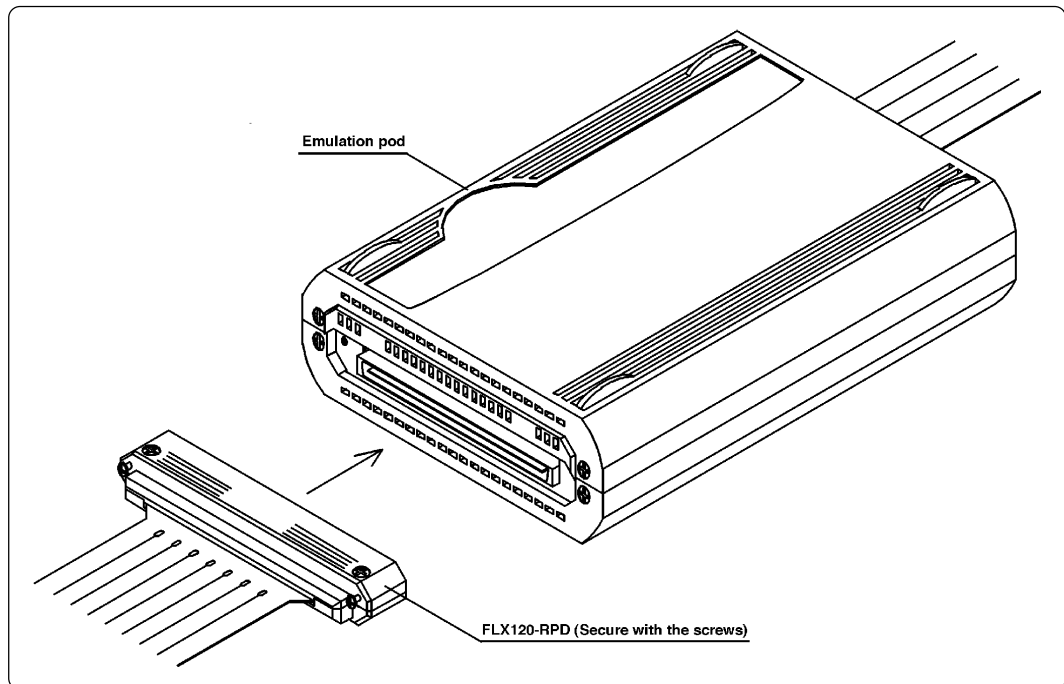

Figure 3.10 Connecting emulation pod and FLX120-RPD

CAUTION

Note on Connecting the Cable:

- Always shut OFF power before connecting the cable. The power ON state could destroy internal circuits.

Note on Securing the Screws:

- After connecting the emulator main unit to the cable, be sure to secure the screws.

3.6 Connecting the Target System

There are seven ways available to connect the emulation pod to target systems as shown in Figure 3.11.

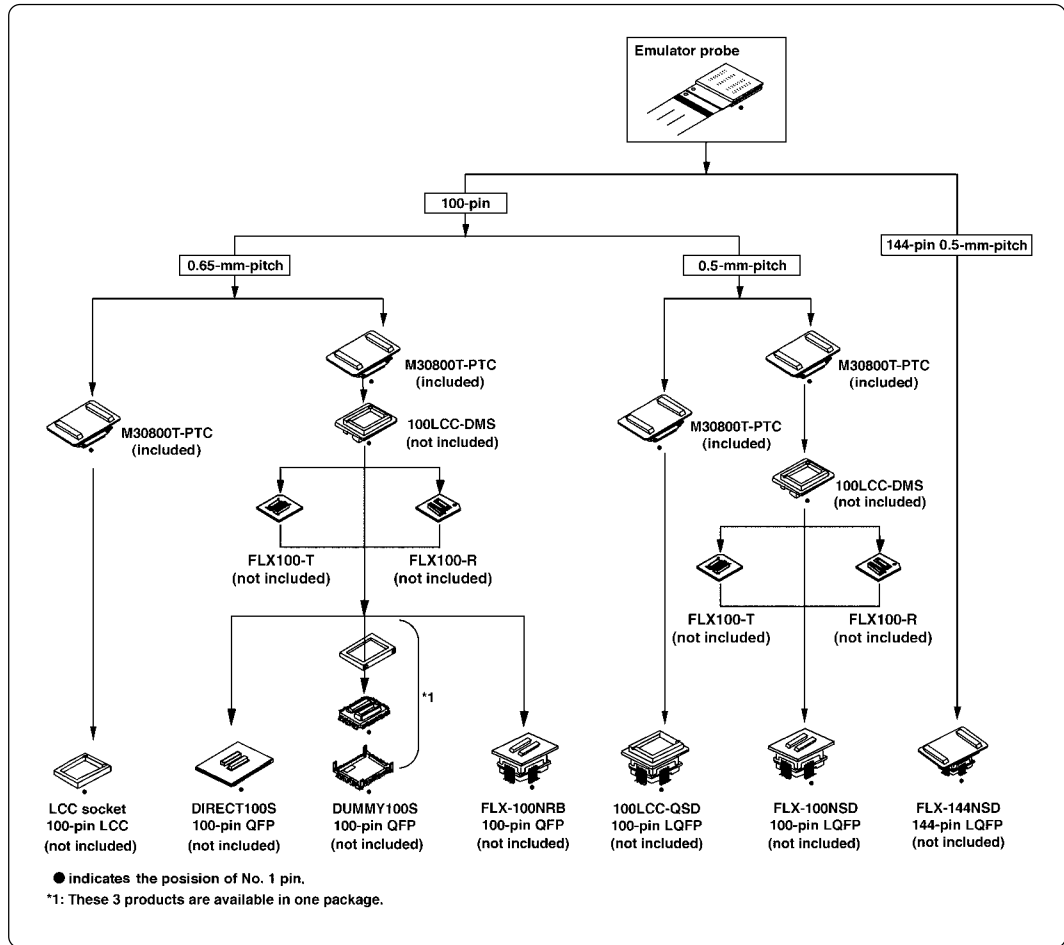

Figure 3.11 Connecting emulation pod and target systems

⚠ CAUTION

Note on Connecting the Target System:

- Take care not to attach the converter board in a wrong direction. It may cause a fatal damage to the emulation pod.

(1) Connecting 100-pin LCC Socket

When connecting the emulation pod probe to the 100-pin LCC socket (Yamaichi Electronics Co., Ltd.: IC51-1004-051 etc.) on the target system, following the procedure below.

- (1) Attach the CN2 side of the FLX160-PRB to the CN2 side of the M30800T-PTC.
- (2) Attach the M30800T-PTC to the 100-pin LCC socket.

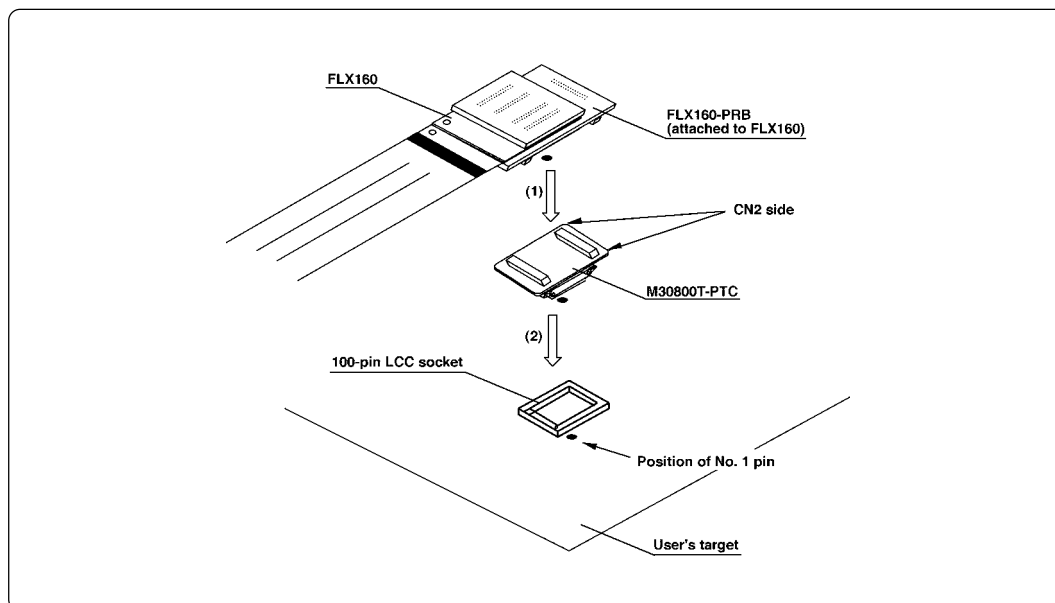

Figure 3.12 Connecting emulation pod and 100-pin LCC socket

CAUTION

Notes on Connecting the Target System:

- Take care not to attach the converter board in a wrong direction. It may cause a fatal damage to the emulation pod.
- The small connectors of M30800T-PTC are guaranteed for only 50 insertion/removal iterations.
- For purchasing the IC51-1004-051 or for technical information, contact Yamaichi Electronics Co., Ltd.

(2) Connecting 100-pin 0.65-mm-pitch Foot Pattern (Part 1)

Figure 3.13 shows how to connect the emulation pod probe to the 100-pin 0.65-mm-pitch foot pattern on the target system with the DUMMY100S (not included), and here following is its procedure. For details on the 100LCC-DMS and DUMMY100S, refer to each user's manual.

- (1) Attach the DUMMY100S to the target system.
- (2) Attach the 100LCC-DMS to the DUMMY100S.
- (3) Attach the M30800T-PTC to the FLX160-PRB.
- (4) Attach the M30800T-PTC to the 100LCC-DMS.

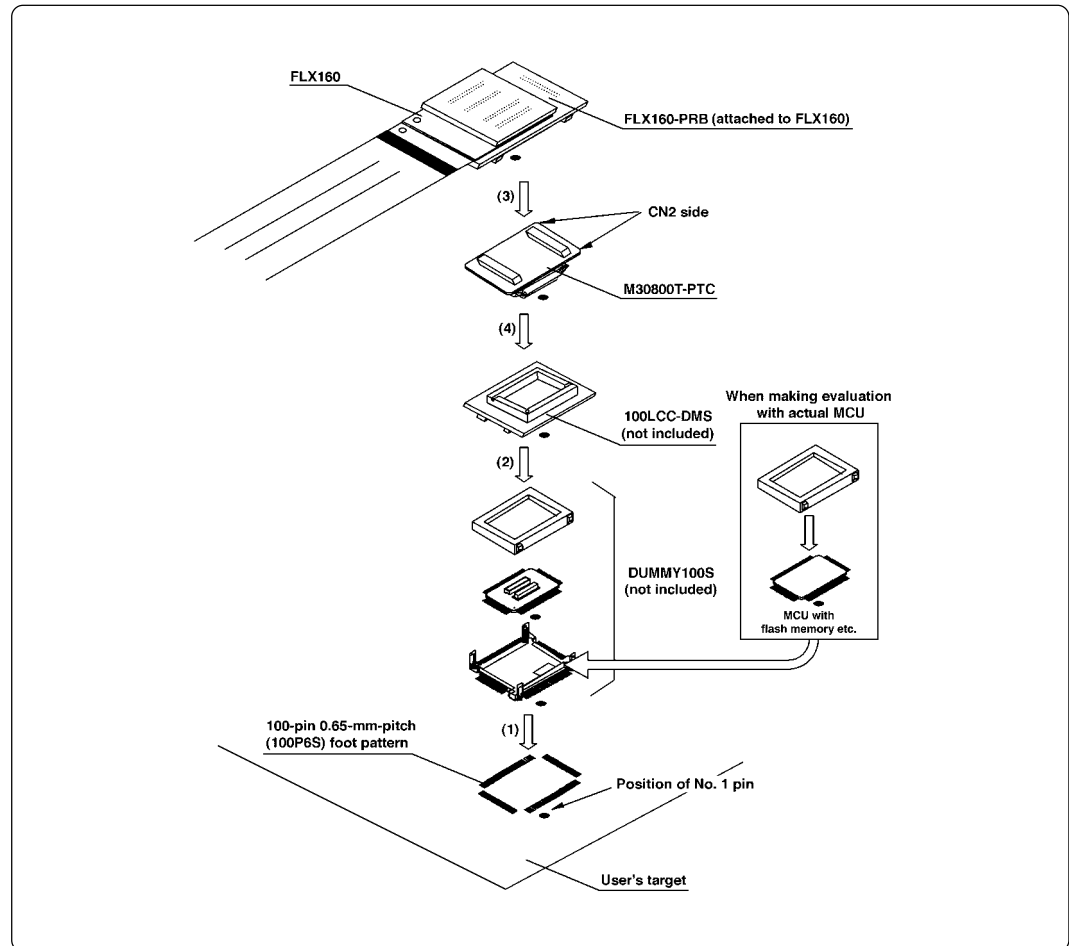

Figure 3.13 Connecting emulation pod probe and 100-pin 0.65-mm-pitch foot pattern (part 1)

CAUTION

Notes on Connecting the Target System:

- Take care not to attach the converter board in a wrong direction. It may cause a fatal damage to the emulation pod.
- The small connectors of 100LCC-DMS and DUMMY100S are guaranteed for only 20 insertion/removal iterations.
- The small connectors of M30800T-PTC are guaranteed for only 50 insertion/removal iterations.

(3) Connecting 100-pin 0.65-mm-pitch Foot Pattern (Part 2)

Figure 3.14 shows how to connect the emulation pod probe to the 100-pin 0.65-mm-pitch foot pattern on the target system with the DIRECT100S (not included), and here following is its procedure. For details on the 100LCC-DMS and DIRECT100S, refer to each user's manual.

- (1) Attach the DIRECT100S to the target system.
- (2) Attach the 100LCC-DMS to the DIRECT100S.
- (3) Attach the M30800T-PTC to the FLX160-PRB.
- (4) Attach the M30800T-PTC to the 100LCC-DMS.

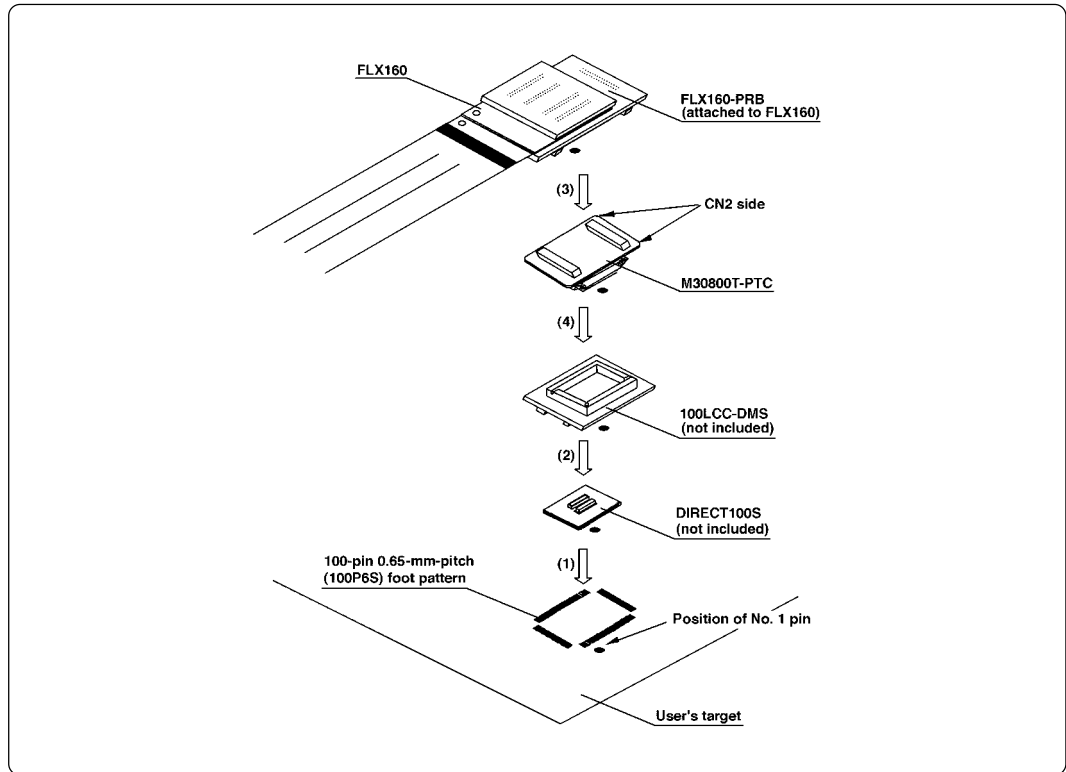

Figure 3.14 Connecting emulation pod probe and 100-pin 0.65-mm-pitch foot pattern (part 2)

CAUTION

Notes on Connecting the Target System:

- Take care not to attach the converter board in a wrong direction. It may cause a fatal damage to the emulation pod.
- The small connectors of 100LCC-DMS and DIRECT100S are guaranteed for only 20 insertion/removal iterations.
- The small connectors of M30800T-PTC are guaranteed for only 50 insertion/removal iterations.

(4) Connecting 100-pin 0.65-mm-pitch Foot Pattern (Part 3)

Figure 3.15 shows how to connect the emulation pod probe to the 100-pin 0.65-mm-pitch foot pattern on the target system with the FLX-100NRB (not included), and here following is its procedure. For details on the 100LCC-DMS and FLX-100NRB, refer to each user's manual.

- (1) Attach the FLX-100NRB to the target system.
For details on how to attach the FLX-100NRB to the target system, see the user's manual of the FLX-100NRB.
- (2) Attach the 100LCC-DMS to the FLX-100NRB.
- (3) Attach the M30800T-PTC to the FLX160-PRB.
- (4) Attach the M30800T-PTC to the 100LCC-DMS.

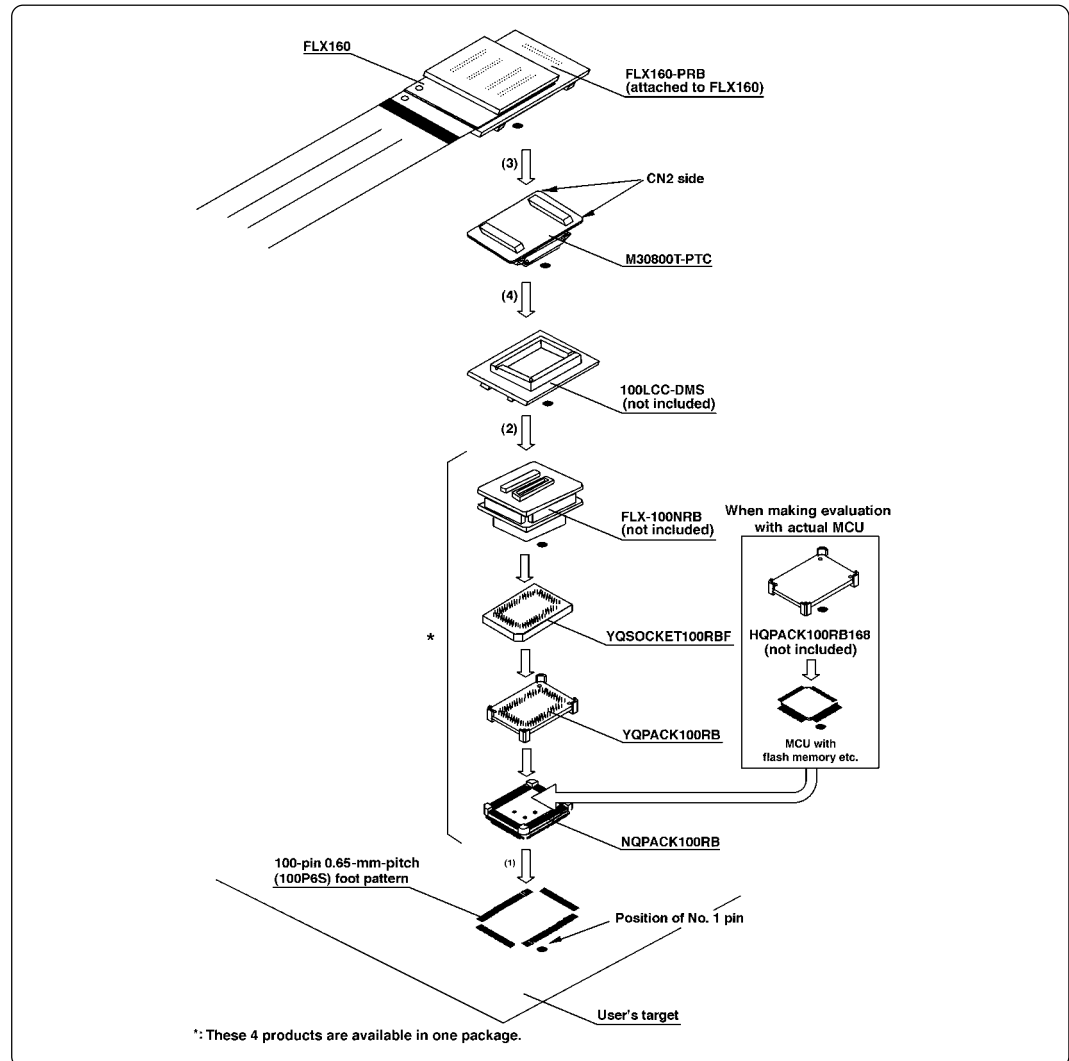

Figure 3.15 Connecting emulation pod probe and 100-pin 0.65-mm-pitch foot pattern (part 3)

⚠ CAUTION

Notes on Connecting the Target System:

- Take care not to attach the converter board in a wrong direction. It may cause a fatal damage to the emulation pod.
- The small connectors of 100LCC-DMS and FLX-100NRB are guaranteed for only 20 insertion/removal iterations.
- The small connectors of M30800T-PTC are guaranteed for only 50 insertion/removal iterations.

(5) Connecting 100-pin 0.5-mm-pitch Foot Pattern (Part 1)

Figure 3.16 shows how to connect the emulation pod probe to the 100-pin 0.5-mm-pitch foot pattern on the target system with the 100LCC-QSD (not included), and here following is its procedure. For details on the 100LCC-QSD, refer to its user's manual.

- (1) Attach the 100LCC-QSD to the target system.
For details on how to attach the 100LCC-QSD to the target system, see the user's manual of the 100LCC-QSD.
- (2) Attach the M30800T-PTC to the FLX160-PRB.
- (3) Attach the M30800T-PTC to the 100LCC-QSD.

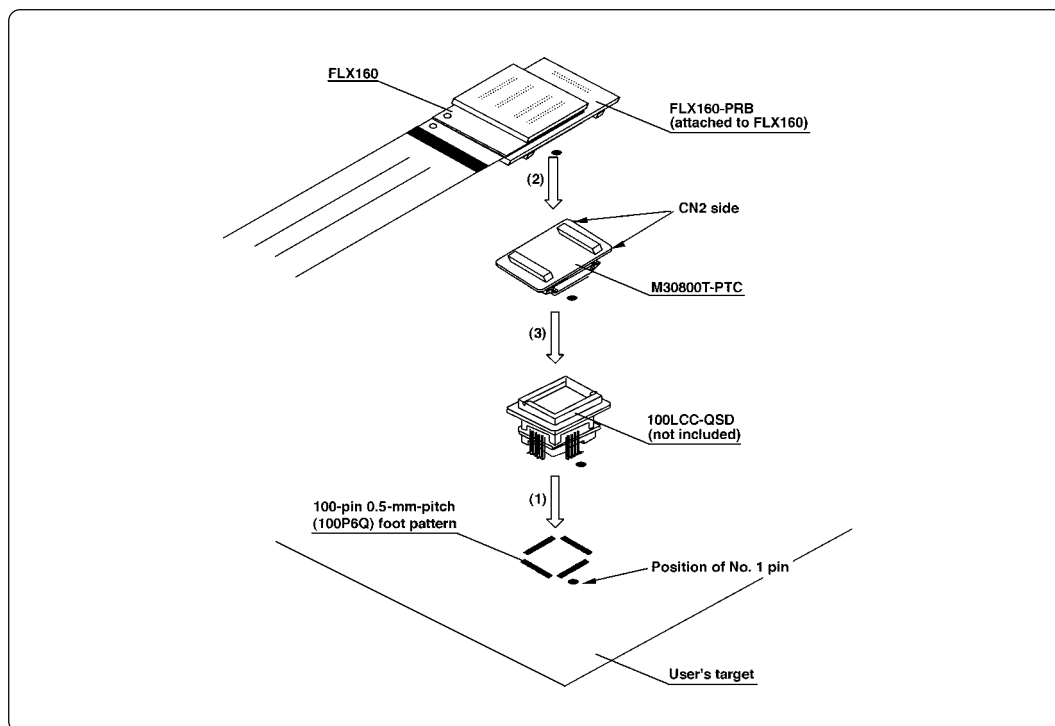

Figure 3.16 Connecting emulation pod probe and 100-pin 0.5-mm-pitch foot pattern (part 1)

CAUTION

Notes on Connecting the Target System:

- Take care not to attach the converter board in a wrong direction. It may cause a fatal damage to the emulation pod.
- The small connectors of M30800T-PTC are guaranteed for only 50 insertion/removal iterations.

(6) Connecting 100-pin 0.5-mm-pitch Foot Pattern (Part 2)

Figure 3.17 shows how to connect the emulation pod probe to the 100-pin 0.5-mm-pitch foot pattern on the target system with the FLX-100NSD (not included), and here following is its procedure. For details on the 100LCC-DMS and FLX-100NSD, refer to each user's manual.

- (1) Attach the FLX-100NSD to the target system.
For details on how to attach the FLX-100NSD to the target system, see the user's manual of FLX-100NSD.
- (2) Attach the 100LCC-DMS to the FLX-100NSD.
- (3) Attach the M30800T-PTC to the FLX160-PRB.
- (4) Attach the M30800T-PTC to the 100LCC-DMS.

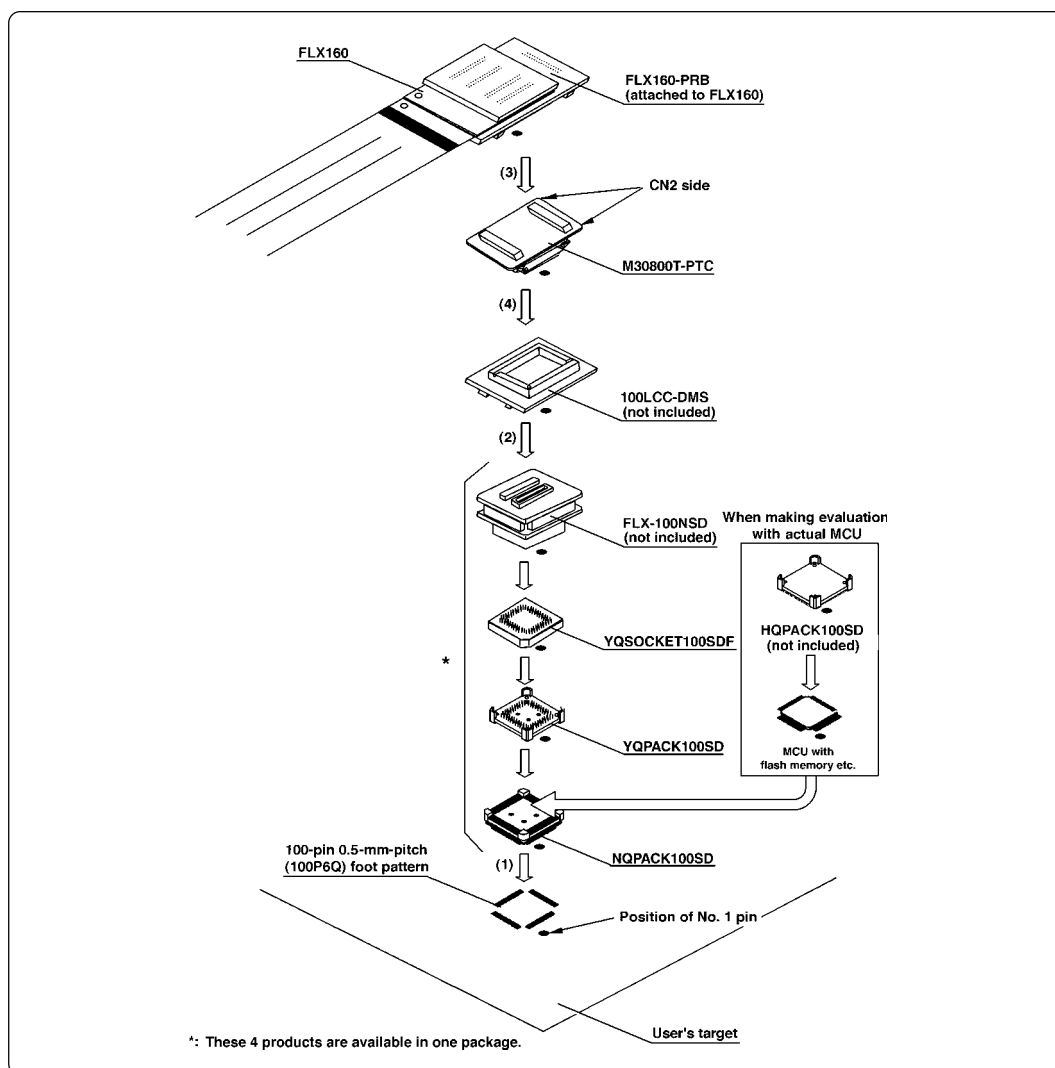

Figure 3.17 Connecting emulation pod probe and 100-pin 0.5-mm-pitch foot pattern (part 2)

CAUTION

Notes on Connecting the Target System:

- Take care not to attach the converter board in a wrong direction. It may cause a fatal damage to the emulation pod.
- The small connectors of 100LCC-DMS and FLX-100NSD are guaranteed for only 20 insertion/removal iterations.
- The small connectors of M30800T-PTC are guaranteed for only 50 insertion/removal iterations.

(7) Connecting 144-pin 0.5-mm-pitch Foot Pattern

Figure 3.18 shows how to connect the emulation pod probe to the 144-pin 0.5-mm-pitch foot pattern on the target system with the FLX-144NSD (not included), and here following is its procedure.

- (1) Attach the NQPACK144SD (NQPACK, hereafter) included with the FLX-144NSD to the target system.
- (2) Attach the YQPACK144SD (YQPACK, hereafter) included with the FLX-144NSD to the NQPACK, matching three holes of NQPACK and YQPACK.
- (3) Insert the YQ-GUIDE's included with the YQPACK to the YQPACK, using the screwdriver included with the NQPACK.
- (4) Attach the FLX160-PRB to the FLX-144NSD.
- (5) Attach the FLX-144NSD to the YQSOCKET144SDF.

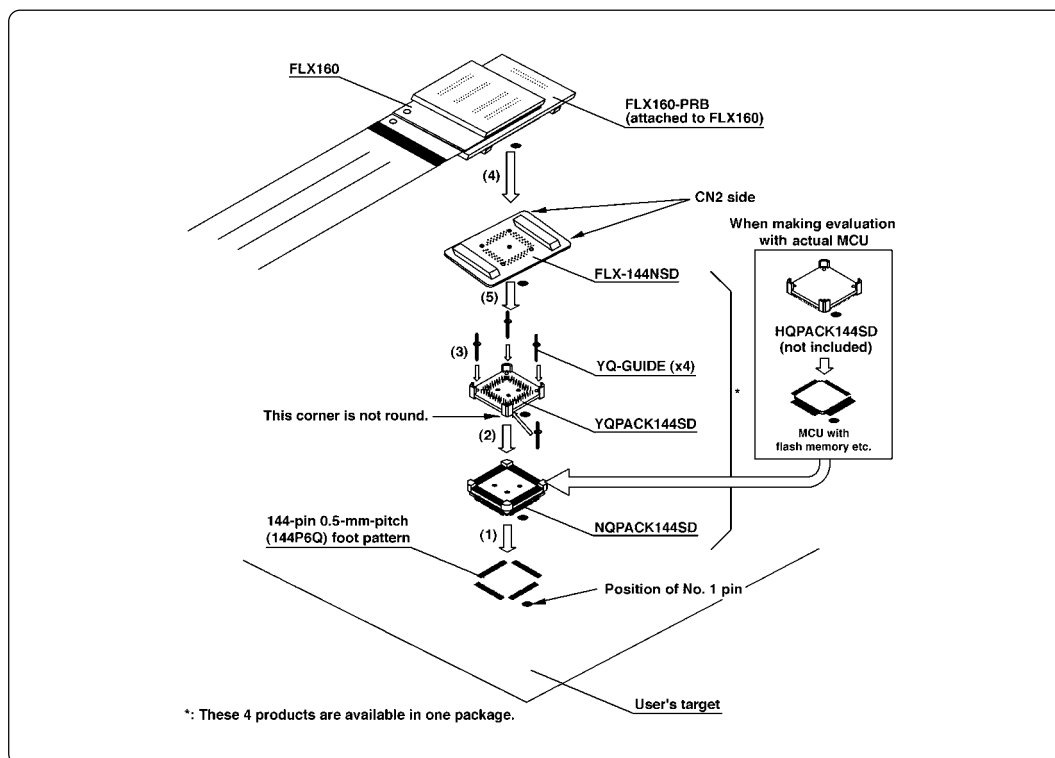

Figure 3.18 Connecting emulation pod probe and 144-pin 0.5-mm-pitch foot pattern

CAUTION

Notes on Connecting the Target System:

- Take care not to attach the converter board in a wrong direction. It may cause a fatal damage to the emulation pod.
- The small connectors of FLX-144NSD are guaranteed for only 50 insertion/removal iterations.

MEMO

Chapter 4. Usage

This chapter describes from turning on the power of this product to starting up the emulator debugger.

4.1	Turning On the Power Supply	46
	(1) Checking the Connection of the System	46
	(2) Turning On the Power Supply	46
	(3) LED Display When PC4701 Starts Up Normally	47
4.2	Downloading Firmware	48
	(1) When It is Necessary to Download Firmware	48
	(2) Downloading Firmware in Maintenance Mode	48
4.3	Starting Up the Emulator Debugger (Setting EMEM Dialog)	49
	(1) Setting the Debug Monitor Bank Address	49
	(2) Selecting the Processor Mode	50
	(3) Setting the Emulation Memory	50
	(4) Emulation Memory Allocation as Expansion Area	50
	(5) Referring MCU STATUS	52
4.4	Self-check	53
	(1) Self-check Procedure	53
	(2) If an Error is Detected in the Self-check	53

Chapter 4. Usage

4.1 Turning On the Power Supply

(1) Checking the Connection of the System

Before turning the power ON, check the connection of the PC4701, emulation pod, converter board and target system.

(2) Turning On the Power Supply

Power ON/OFF the target system and the PC4701 as simultaneously as possible.



Notes on Power Supply:

- The emulator's V_{CC} pin is connected to the target system in order to monitor target system voltage. For this reason, the emulator cannot supply power to the target system. Therefore, provide the target system with a separate power supply from that of the emulator.
- Keep target system power supply voltage within the MCU's specified range (+2.7 and 5.5 V).
- Do not change target system power supply voltage after power has been activated.

(3) LED Display When PC4701 Starts Up Normally

After the emulator starts up, check the status of the LEDs on the front panel to see whether emulation pod operation is enabled or not. Figure 4.1 shows front panel LED lighting status when the emulator is turned ON.

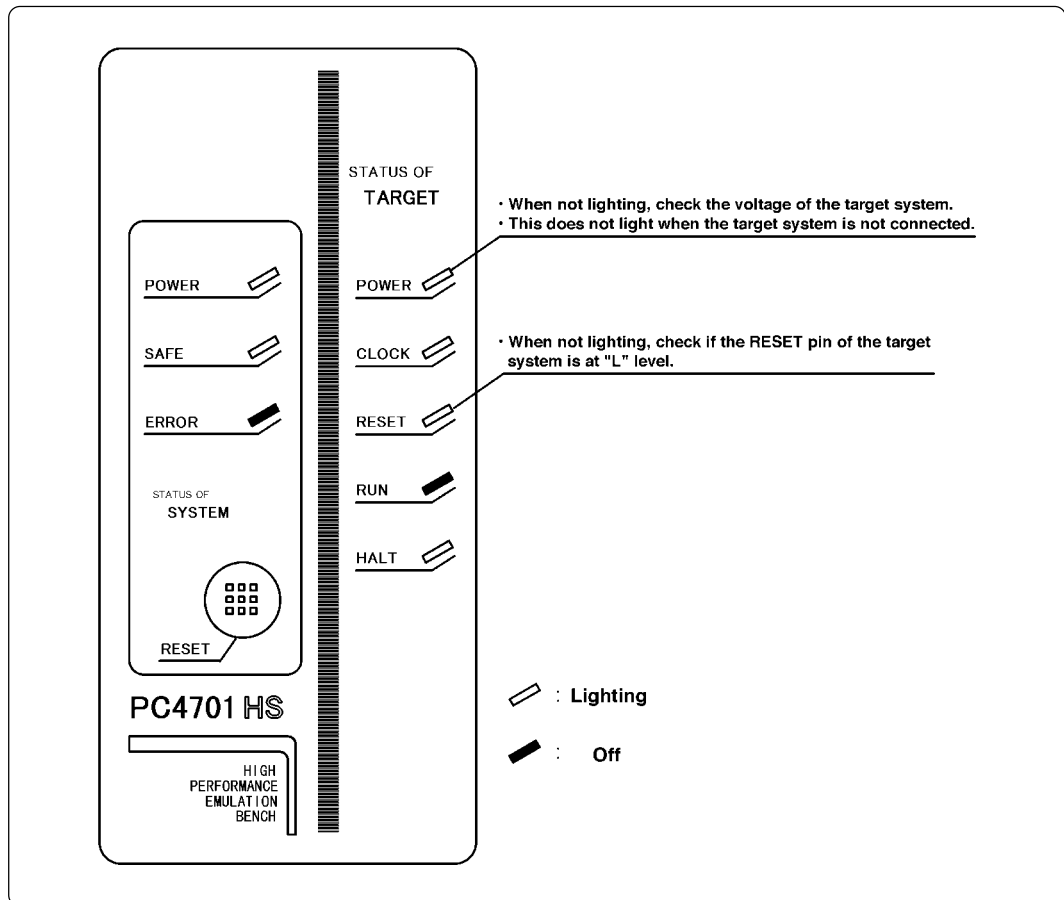

Figure 4.1 LED display when the power turned on

IMPORTANT

Note on Memory Expansion Mode and Microprocessor Mode:

- To use the memory expansion or microprocessor mode, be sure to set the RDY*, HOLD* and NMI* pins so that they are not active at startup. Otherwise the emulator system will not function correctly.

Note on CLOCK LED:

- If CLOCK LED does not turn on, check the following points:
 - (1) Immediately after starting PC4701 (before starting the emulator debugger)
 - > Check if the oscillation circuit within the emulation pod oscillates normally.
 - (2) After starting the emulator debugger (after setting the Init dialog)
 - > Check the oscillation circuit set in the Init dialog oscillates normally.

4.2 Downloading Firmware

(1) When It is Necessary to Download Firmware

It is necessary to download firmware when:

- (1) you use this product for the first time
- (2) the firmware is upgraded
- (3) the emulator debugger is upgraded
- (4) use this product with the PC4701 which was used with other emulation pod before

(2) Downloading Firmware in Maintenance Mode

Download the firmware in maintenance mode as explained here following. The target system must not be connected when downloading the firmware.

- (1) Within 2 seconds of activating power to the emulator, press the RESET button on the emulator front panel. This will switch the emulator to maintenance mode.
- (2) Start up the emulator debugger. When the Init dialog box setup is completed, the dialog which urges to download the firmware will appear. Download the firmware following messages. Required time for downloading the firmware depends on the connection of the interface.

- For serial interface approx. 7 minutes
- For parallel interface approx. 30 seconds

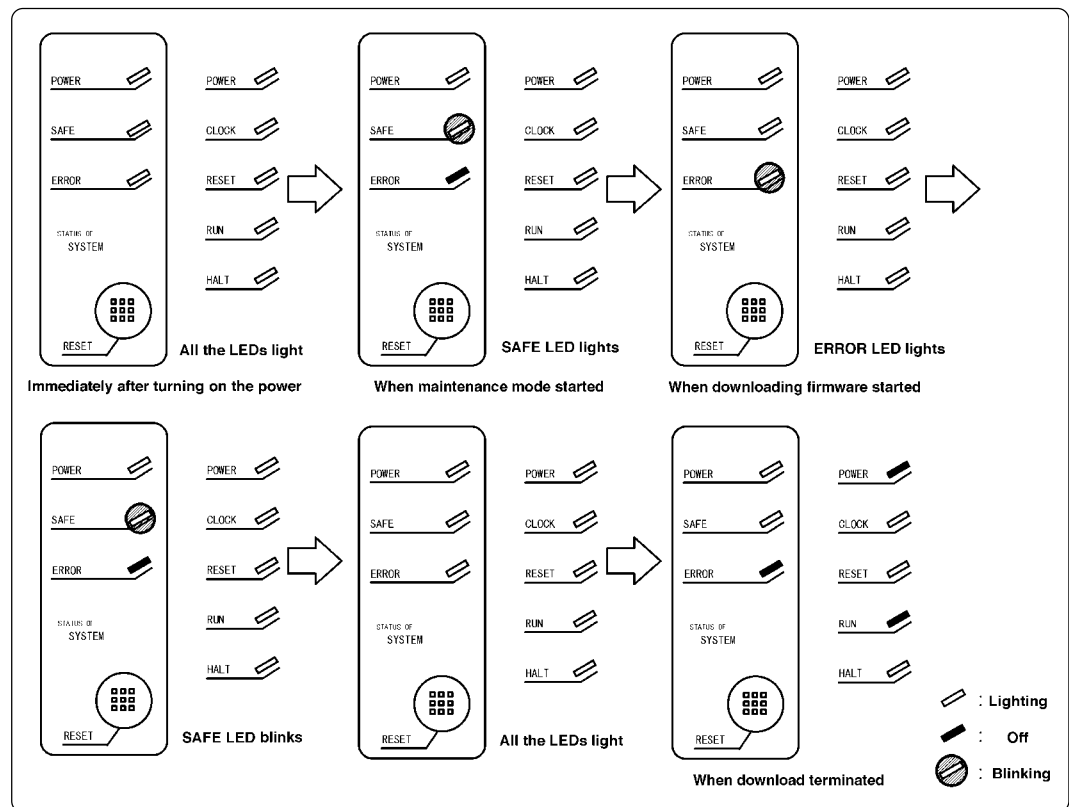

Figure 4.2 Downloading firmware in maintenance mode

IMPORTANT

Note on Downloading Firmware:

- Do not shut OFF power while the firmware is being downloaded. Doing so, the emulator will not start up properly. If power is shut OFF by mistake, redownload the firmware in maintenance mode.

4.3 Starting Up the Emulator Debugger (Setting EMEM Dialog)

The EMEM dialog will appear after setting the Init dialog by starting up the emulator debugger or completing downloading the firmware. Here explains how to set the processor mode of the target MCU, allocate the emulation memory and set the emulator work area. Figure 4.3 shows the EMEM dialog display.

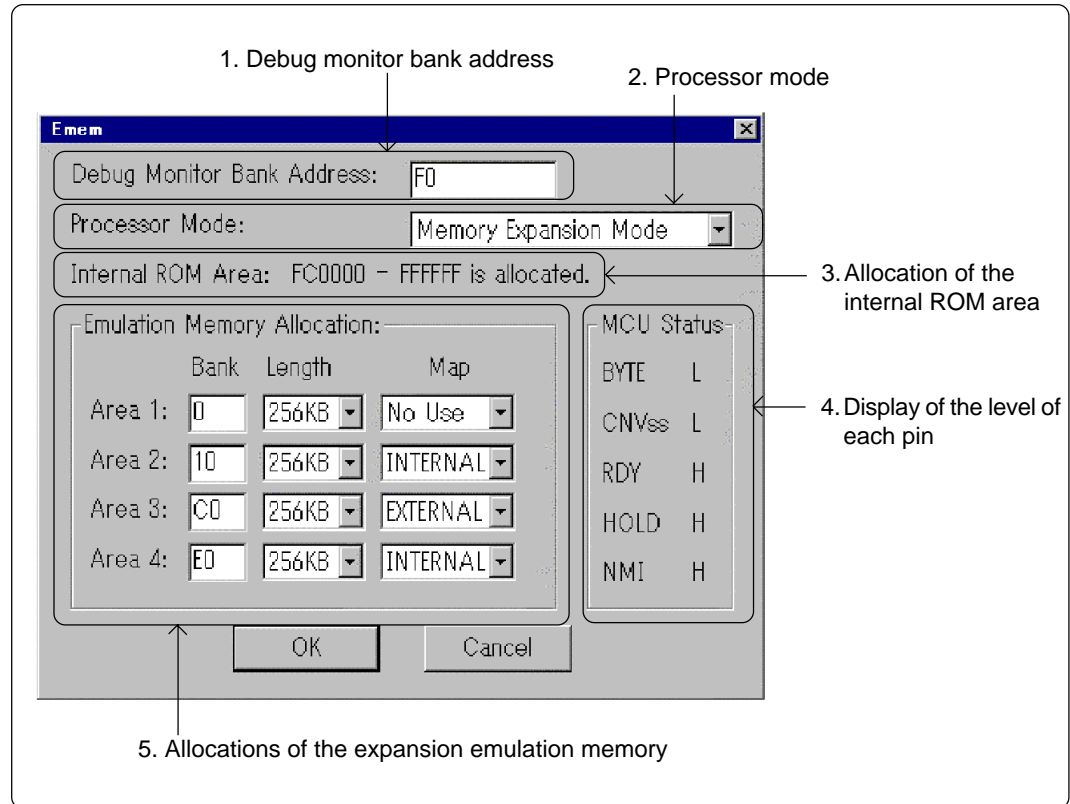

Figure 4.3 EMEM dialog

(1) Setting the Debug Monitor Bank Address

With this product, 64 consecutive KB of the emulator's work area are allocated to the debug monitor. When "F0" is specified, 64 KB starting from address F00000h are allocated for use by the debug monitor. Specify an unused area.

IMPORTANT

Notes on Setting Debug Monitor Bank Address:

- It is not possible to view or set the content of the specified area. Even on the dump window or in the reverse assemble area of the program/source windows, the content of this area is not displayed correctly though it can be displayed.
- The below bank addresses cannot be set for the debug monitor.
 - (1) MCU internal resources (RAM/SFR area)
 - (2) DRAM area or multiplex area
 - (3) Interrupt vector area

(2) Selecting the Processor Mode

Here explains about the setting of processor mode. Selectable modes are listed in Table 4.1.

Table 4.1 Selecting the processor mode

Processor mode	Select from the list
Single-chip mode	Single-chip Mode
Memory expansion mode	Memory Expansion Mode
Microprocessor mode	Microprocessor Mode

IMPORTANT

Notes on Selecting the Processor Mode:

- When setting single-chip mode and memory expansion mode, the level of the CNVss pin of the target system should be "L".
- When setting microprocessor mode, the level of the CNVss pin of the target system should be "H".
- When setting memory expansion mode or microprocessor mode, the RDY* and HOLD* pins of the target system should be "H".

(3) Setting the Emulation Memory

This product has two emulation memory and how to allocate is different depending on which processor mode is selected. Table 4.2 shows how to set the emulation memory for each processor mode.

Table 4.2 Setting the emulation memory

Processor mode	Emulation memory for internal ROM	Emulation memory for expansion area
Single-chip Mode	The area FC0000h-FFFFFFh is allocated automatically.	Cannot be used.
Memory Expansion Mode	The area FC0000h-FFFFFFh is allocated automatically.	Possible to specify the desired area between Area 1 and 4.
Microprocessor Mode	Cannot be used.	Possible to specify the desired area between Area 1 and 4.

(4) Emulation Memory Allocation as Expansion Area

This section explains about setting emulation memory for expansion purposes in the memory expansion mode and microprocessor mode. To use emulation memory as expansion area, set memory allocation as indicated here below. Emulation memory specifications are given in Table 4.3.

- (1) Setting bank address (Bank): Specify the bank address of the area to be allocated for expansion as a hexadecimal number.

For example, specifying "C0" allocates the bank from address C00000h.

When 256 KB is specified as the Length, bank addresses can be specified in 256KB blocks up to 00, 04, 08 and - FC.

When 1 MB is specified as the Length, bank addresses can be specified in 1MB blocks up to 00, 10, 20 and - F0.

(2) Specifying area size (Length): Specify the size of the specified expansion area. The area from the specified address to the size specified here is allocated as external area or internal area. Length can be specified as 256 KB or 1 MB.

(3) Specifying area map (Map): Select whether the specified area is to be allocated as internal area (used as emulation memory) or external area (used by external device, etc.).

- When INTERNAL is specified: This bank is allocated as internal area and used for expansion.
- When EXTERNAL is specified: This bank is allocated as external area and used by the target system as an external resource.
- When No Use is specified: This bank is allocated as external area and used by the target system as an external resource.

Areas not specified here are allocated as external area. The only difference from the area specified as EXTERNAL area is download speed. Download to the area specified as EXTERNAL area is faster than to other areas.

IMPORTANT

Notes on Using Emulation Memory for Expansion:

- When the single-chip mode and memory expansion mode are set by specifying the processor mode, emulation memory is automatically allocated to the internal ROM area. Therefore, it is not necessary to deliberately specify emulation memory as expansion area in order to allocate the internal ROM area.
- The 1.5MB memory mounted in the product can be allocated out. Set memory allocation so that the total of the 4 length values does not exceed the emulation memory size (1.5 MB).
- Be careful that the specified areas do not overlap one another.
- Even when "00" is specified as the expansion area, internally reserved areas (006400h - 007FFFh) cannot be used.
- Do not set the following areas for memory allocation of the MCU. Set these areas referring the specifications of the MCU.
 - (1) Area allocated for DRAM connection
 - (2) Area allocated for multiplex bus
 - (3) Unusable area
- Emulation pod memory is automatically selected as reset vector area regardless of settings.
- Except for the SFR, RAM, ROM and internally reserved areas, all areas other than the set area are externally accessible.
- MCU internal resources are automatically selected as SFR and RAM areas regardless of settings.

Table 4.3 Specifications of expansion emulation memory

Maximum operating frequency	20 MHz, 1 wait
Number of area which can be set	Max. 4 areas
Area size	Successive 256 KB or 1 MB
Emulation memory size	Total of 4 areas: 1.5 MB
Possible bank to be set	(1) For area size 256 KB X0h, X4h, X8h, XCh bank e.g.) 20 bank, 64 bank, A8 bank, EC bank etc. (2) For area size 1 MB X0h bank e.g.) 20 bank, 40 bank, 80 bank, A0 bank etc.
Possible combination of areas	(1) 256 KB (2) 256 KB + 256KB (3) 256 KB + 256KB + 256KB (4) 256KB + 256KB + 256KB + 256KB (5) 1 MB (6) 1 MB + 256 KB (7) 1 MB + 256 KB + 256 KB (8) none

IMPORTANT

Note on Memory Access:

- When setting the processor mode to the memory expansion mode, it may be changed to the memory expansion mode temporarily before the user program itself changes from the single-chip mode to the memory expansion mode.

Take due consideration on this phenomenon in the following cases:

- (1) Immediately before executing the program after setting a software break
- (2) Immediately after stopping the program when a software break is set

(5) Referring MCU STATUS

It is possible to confirm each level of BYTE, CNVss, RDY*, HOLD*, NMI* pins on the target system.

IMPORTANT

Notes on MCU STATUS:

- The status of pins of MCU is displayed in the "MCU STATUS" of the EMEM dialog. Confirm if it matches with the processor mode.
- Check that "RDY", "HOLD" and "NMI" are set to "H". If they are set to the "L" level, the MCU itself is in the standby state. The emulator debugger displays an error message because it receives no response from the MCU.

4.4 Self-check

(1) Self-check Procedure

To run the emulator self-check, do so as explained here below. While the self-check is in progress, LEDs will change as shown in Figure 4.5.

- (1) Set the switches in the emulation pod same as the factory setting (see Figure 4.4).
- (2) When the target system is connected, disconnect the target system.
- (3) Within 2 seconds of activating power to the emulator, press the RESET button on the emulator front panel to switch the emulator to maintenance mode.
- (4) Check the "SAFE" LED starts flashing and then press the RESET button again.
- (5) The self-check will start. If the normal result is displayed in about 1 minute, the self-check has terminated normally.

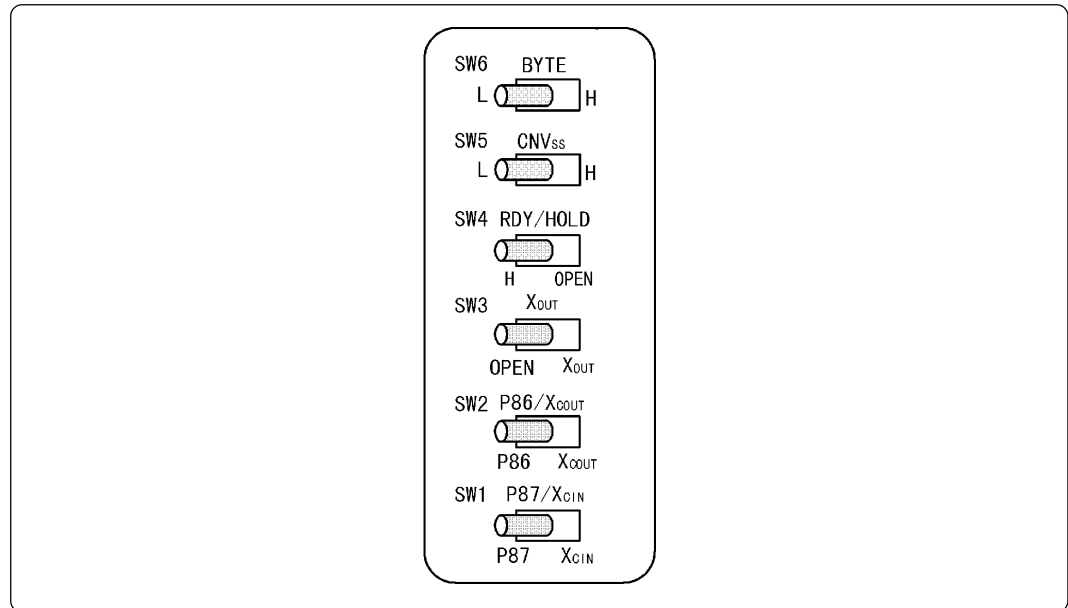

Figure 4.4 Switch settings when running the self-check

(2) If an Error is Detected in the Self-check

If the self-check does not result normally (ERROR 1 or ERROR 2 in Figure 4.5), check the following.

- Check the connection of the emulation pod and the PC4701.
- Redownload the proper firmware.
- Check if the switches in this product is set same as the factory-setting ("Figure 3.2 Positions of switches and their factory-settings", page 25).

IMPORTANT

Note on Self-check:

- If the self-check does not result normally (excluding target system errors), the emulation pod may be damaged. Contact your local distributor.

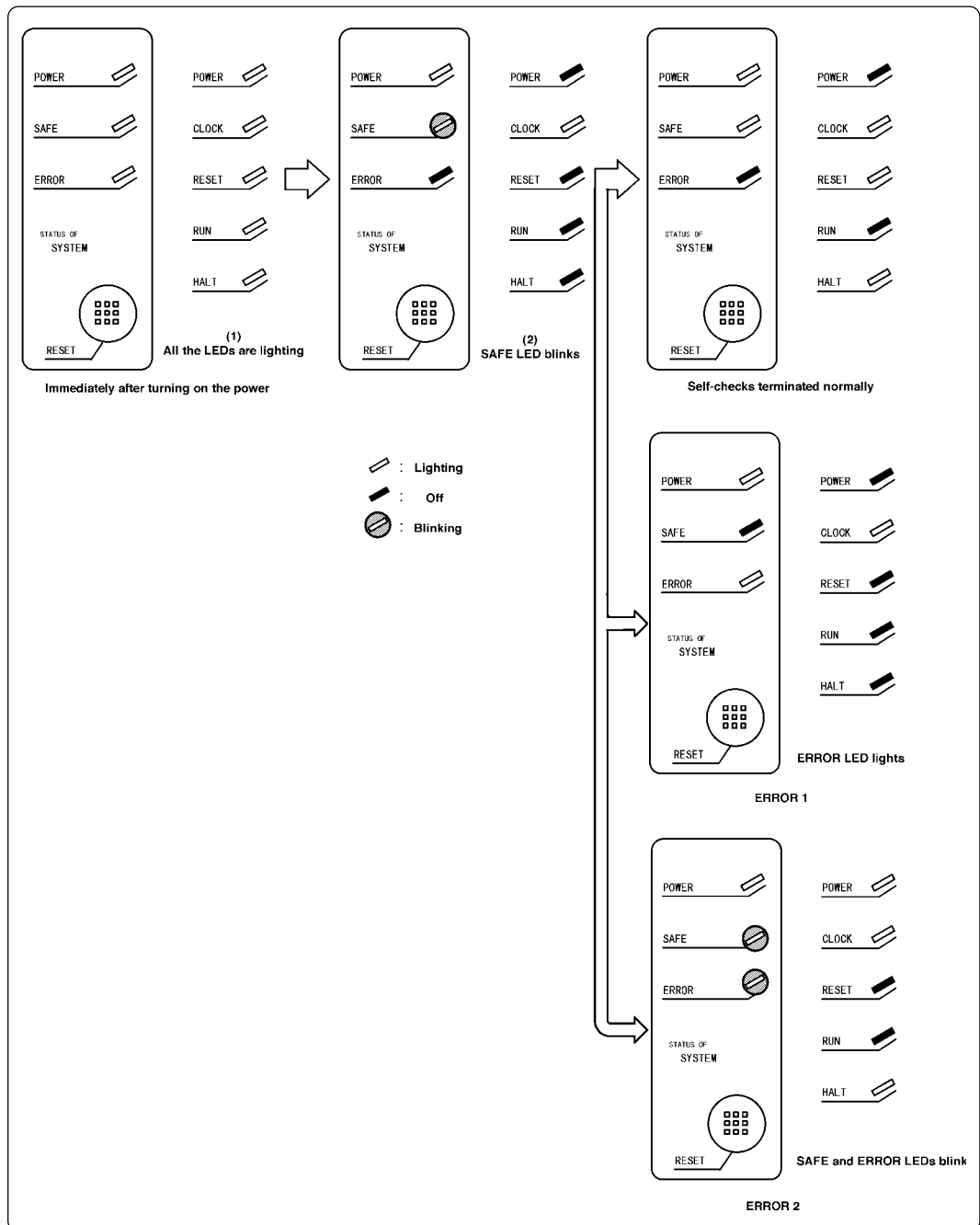

Figure 4.5 Self-check procedure

Chapter 5. Specifications

This chapter describes specifications of this product.

5.1 Specifications	56
5.2 Connection Diagram	57
5.3 Operation Timing in Memory Expansion Mode and Microprocessor Mode	59
(1) Timing Requirements	59
5.4 Electrical Characteristics	59
5.5 External Dimensions	60
(1) External Dimensions of Emulation Pod	60
(2) External Dimensions of Converter Board (M30800T-PTC)	61
(3) External Dimensions of Converter Board (FLX-144NSD)	62

Chapter 5. Specifications

5.1 Specifications

Table 5.1 lists the specifications of the M30803T-RPD-E.

Table 5.1 Specifications of the M30803T-RPD-E

Emulator	PC4701	
Applicable MCUs	10KB RAM: M30800 (100-pin) 128KB ROM: M30802 (144-pin)*	
	24KB RAM: M30803 (100-pin) 256KB ROM: M30805 (144-pin)*	
Evaluation MCU	M30805SGP (two pieces)	
Usable modes	Single-chip mode Memory expansion mode Microprocessor mode	
Emulation memory	(1) 256 KB for internal ROM of MCU (Fixed FC0000h - FFFFFFFh, maximum operating frequency: 20 MHz, 0 wait) (2) 1.5 MB (changeable) for expansion area (Possible to allocate by 256 KB or 1 MB, maximum operating frequency: 20 MHz, 1 wait)	
Maximum operating frequency	20 MHz (Operating voltage: 5.0 to 5.5 V, divide-by-1) 10 MHz (Operating voltage: 2.7 to 5.5 V, divide-by-1)	
Clock oscillator	X _{IN} -X _{OUT}	Internal oscillator circuit board (OSC-3) Switchable to external oscillator input
	X _{CIN} -X _{COU} T	Internal oscillator circuit board (32.768 kHz fixed) Switchable to external oscillator input
Operating frequency	2.7 to 5.5 V	
Operating temperature	5 to 35°C (no dew)	
Storage temperature	-10 to 60°C (no dew)	
Power supply to emulation pod	Supplied from PC4701	
Connection to target system (see 3.6 "Connecting the Target System" on page 36)	<p>For 144-pin 0.5-mm-pitch LQFP (144P6Q-A): FLX-144NSD (not included)</p> <p>For 100-pin 0.5-mm-pitch LQFP (100P6Q-A): (1) M30800T-PTC (included) + 100LCC-QSD (not included) (2) M30800T-PTC (included) + 100LCC-DMS (not included) + FLX-100NSD (not included)</p> <p>For 100-pin 0.65-mm-pitch QFP (100P6S-A): (1) M30800T-PTC (included) + 100LCC-DMS (not included) + DUMMY100S (not included) (2) M30800T-PTC (included) + 100LCC-DMS (not included) + DIRECT100S (not included) (3) M30800T-PTC (included) + 100LCC-DMS (not included) + FLX-100NRB (not included)</p> <p>For 100-pin LCC socket: M30800T-PTC (included)</p>	
Overseas standards	<ul style="list-style-type: none"> • U.S. EMI standards (FCC part 15 Class A) • CE marking (EN55022, EN50082-1) 	

* For M30802 and M30805, the FLX-144NSD (not included) is required.

5.2 Connection Diagram

Figures 5.1 and 5.2 show the connection diagram of the M30803T-RPD-E. This connection diagram mainly shows the interface section, and the circuits which are not connected to the target system such as the emulator's control system are omitted.

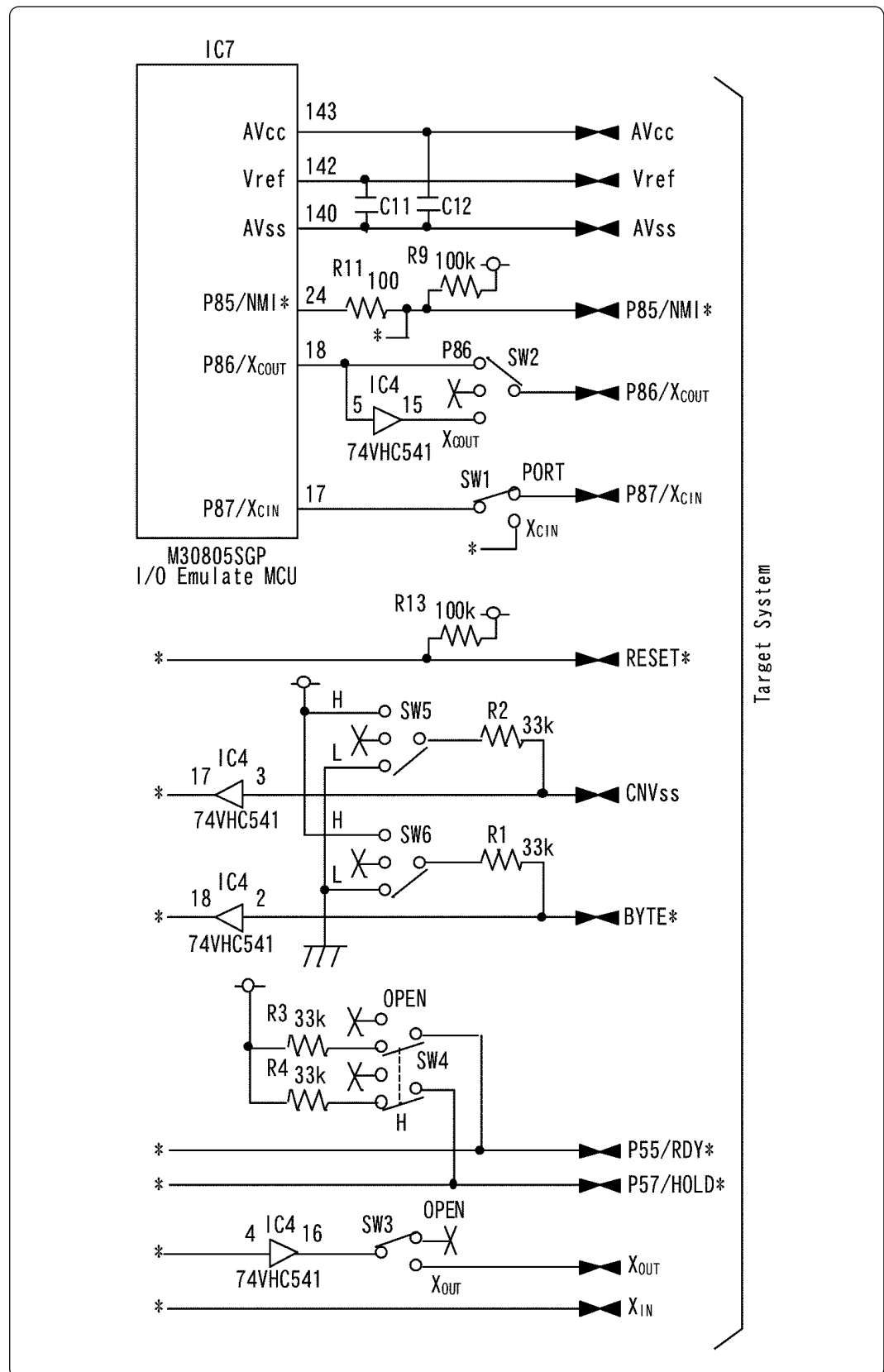

Figure 5.1 Connection diagram 1/2

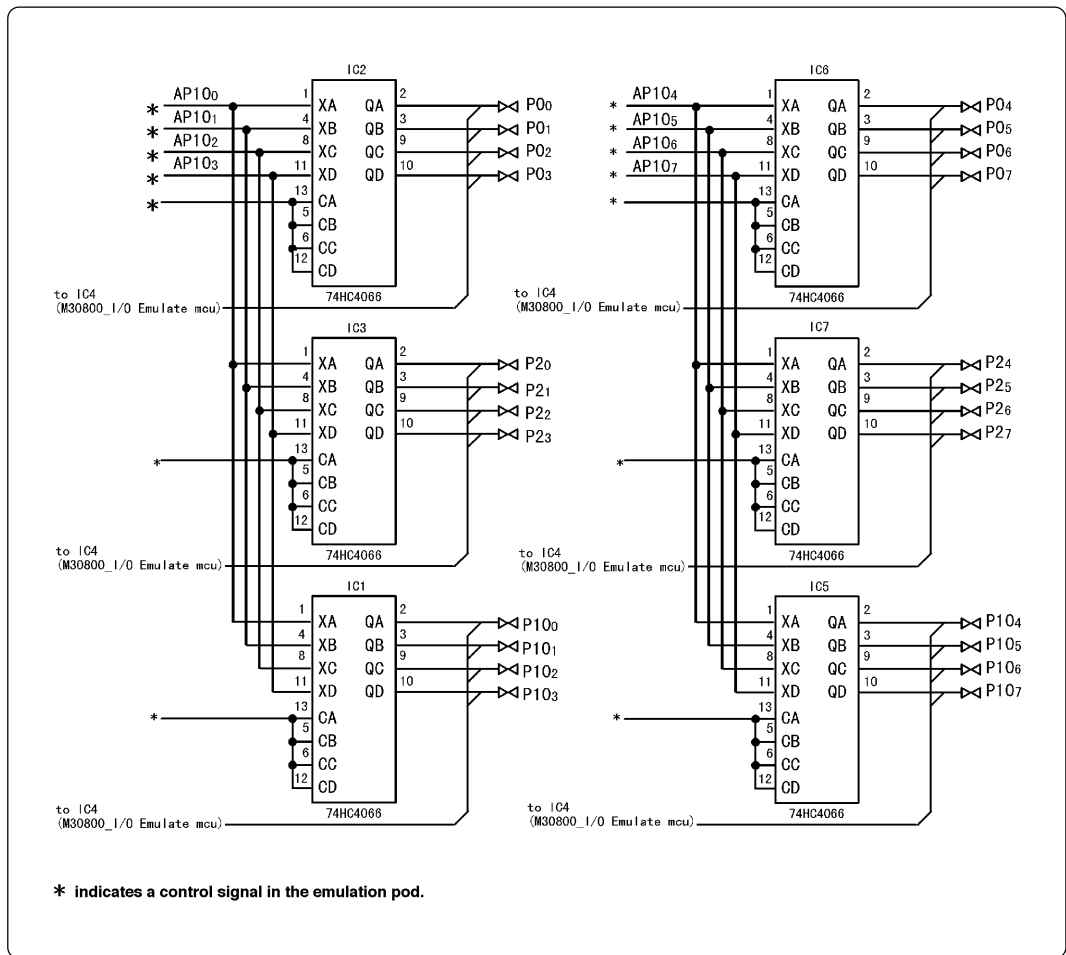

Figure 5.2 Connection diagram 2/2

5.3 Operation Timing in Memory Expansion Mode and Microprocessor Mode

As there are a flexible cable and other devices between this product and the target system, I/O timing will differ from that of the actual MCU. Use the following as a reference when using the emulation pod.

- (1) The output signal (address, RD*, WR*, etc.) of the evaluation MCU mounted on this product is output delayed by about 4 ns.
- (2) It takes longer time to setup the data than actual MCU by approx. 8 ns.

(1) Timing Requirements

Tables 5.2 and 5.3 list the timing requirements.

Table 5.2 Timing requirements (VCC = 5 V)

Symbol	Item	Actual MCU		This product		Unit
		Min.	Max.	Min.	Max.	
tsu (DB-BCLK)	Data input setup time	26		34		ns
tsu (RDY-BCLK)	RDY* input setup time	26		34		ns
tsu (HOLD-BCLK)	HOLD* input setup time	30		38		ns
th (RD-DB)	Data input hold time	0		0		ns
th (CAS-DB)	Data input hold time	0		0		ns
th (BCLK-RDY)	RDY* input hold time	0		0		ns
th (BCLK-HOLD)	HOLD* input hold time	0		0		ns
td (BCLK-HLDA)	HLDA* output delay time		25		25	ns

Table 5.3 Timing requirements (VCC = 3 V)

Symbol	Item	Actual MCU		This product		Unit
		Min.	Max.	Min.	Max.	
tsu (DB-BCLK)	Data input setup time	40		48		ns
tsu (RDY-BCLK)	RDY* input setup time	60		68		ns
tsu (HOLD-BCLK)	HOLD* input setup time	80		88		ns
th (RD-DB)	Data input hold time	0		0		ns
th (CAS-DB)	Data input hold time	0		0		ns
th (BCLK-RDY)	RDY* input hold time	0		0		ns
th (BCLK-HOLD)	HOLD* input hold time	0		0		ns
td (BCLK-HLDA)	HLDA* output delay time		100		100	ns

5.4 Electrical Characteristics

Table 5.4 shows IC electrical characteristics of the user interface. Use this as a reference when using the emulator.

Table 5.4 Electrical characteristics of port P10 (TC74HC4066)

Symbol	Parameter	Measuring condition	Standard values			Unit
		Vcc	Min.	Standard	Max.	
V _{IHC}	High level control input voltage	2.0	1.50	-	-	V
		4.5	3.15	-	-	
V _{ILC}	Low level control input voltage	2.0	-	-	0.50	
		4.5	-	-	1.35	
I _{IN}	Input current	12.0	-	-	±100	nA

5.5 External Dimensions

(1) External Dimensions of Emulation Pod

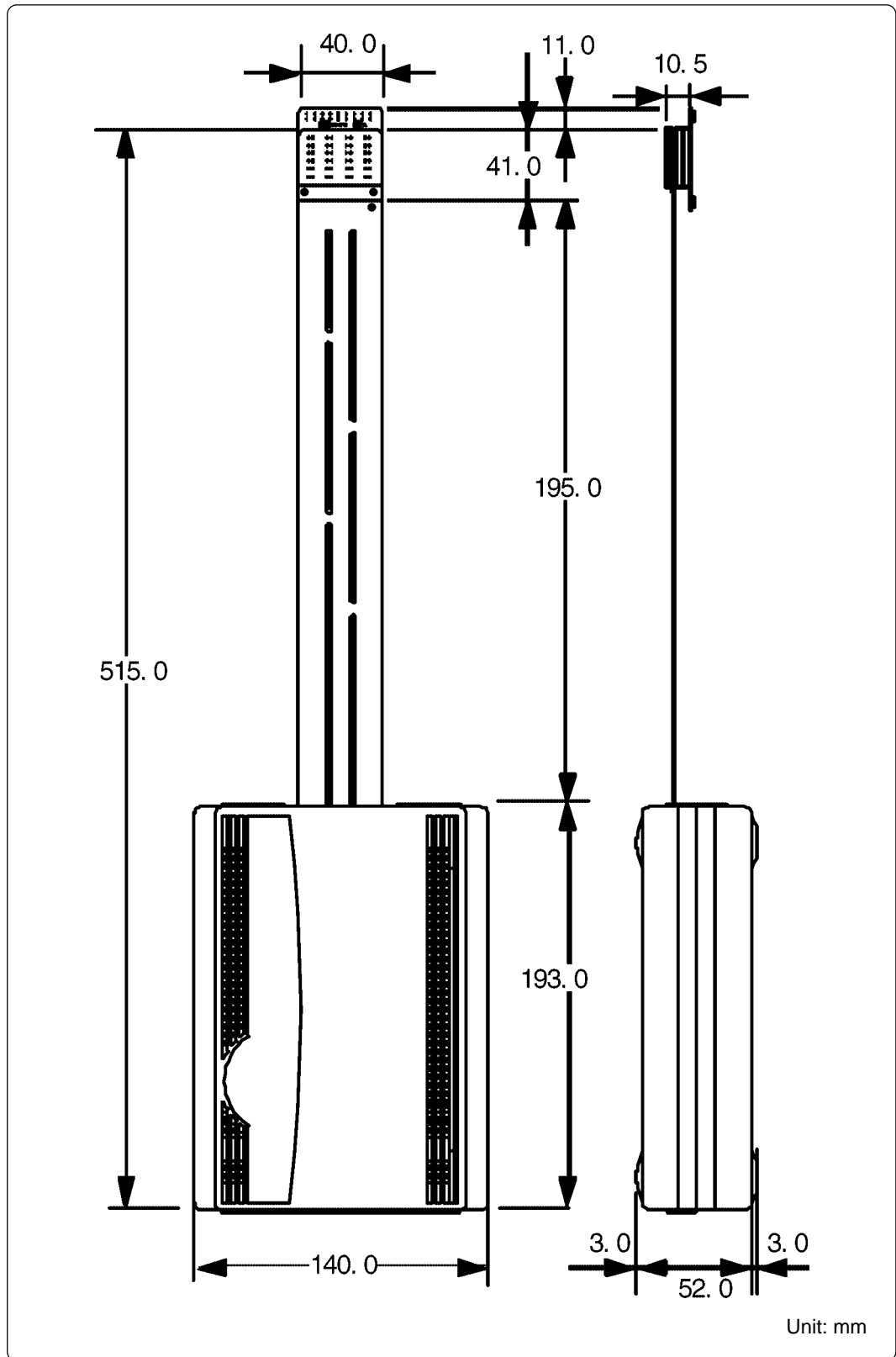

Figure 5.3 External dimensions of emulation pod

(2) External Dimensions of Converter Board (M30800T-PTC)

Figure 5.4 shows the external dimensions of the converter board M30800T-PTC for 100-pin QFP (100P6N).

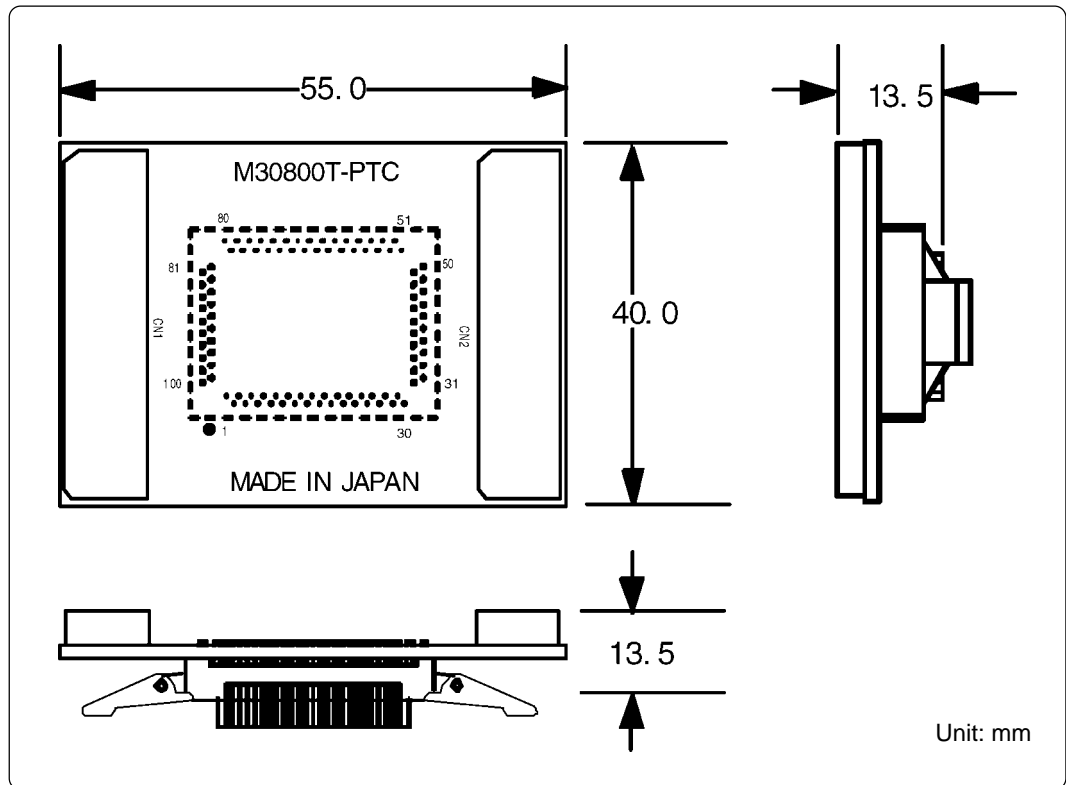

Figure 5.4 External dimensions of converter board (M30800T-PTC)

(3) External Dimensions of Converter Board (FLX-144NSD)

Figure 5.5 shows the external dimensions and the foot pattern of the converter board FLX-144NSD for 144-pin LQFP (144P6Q).

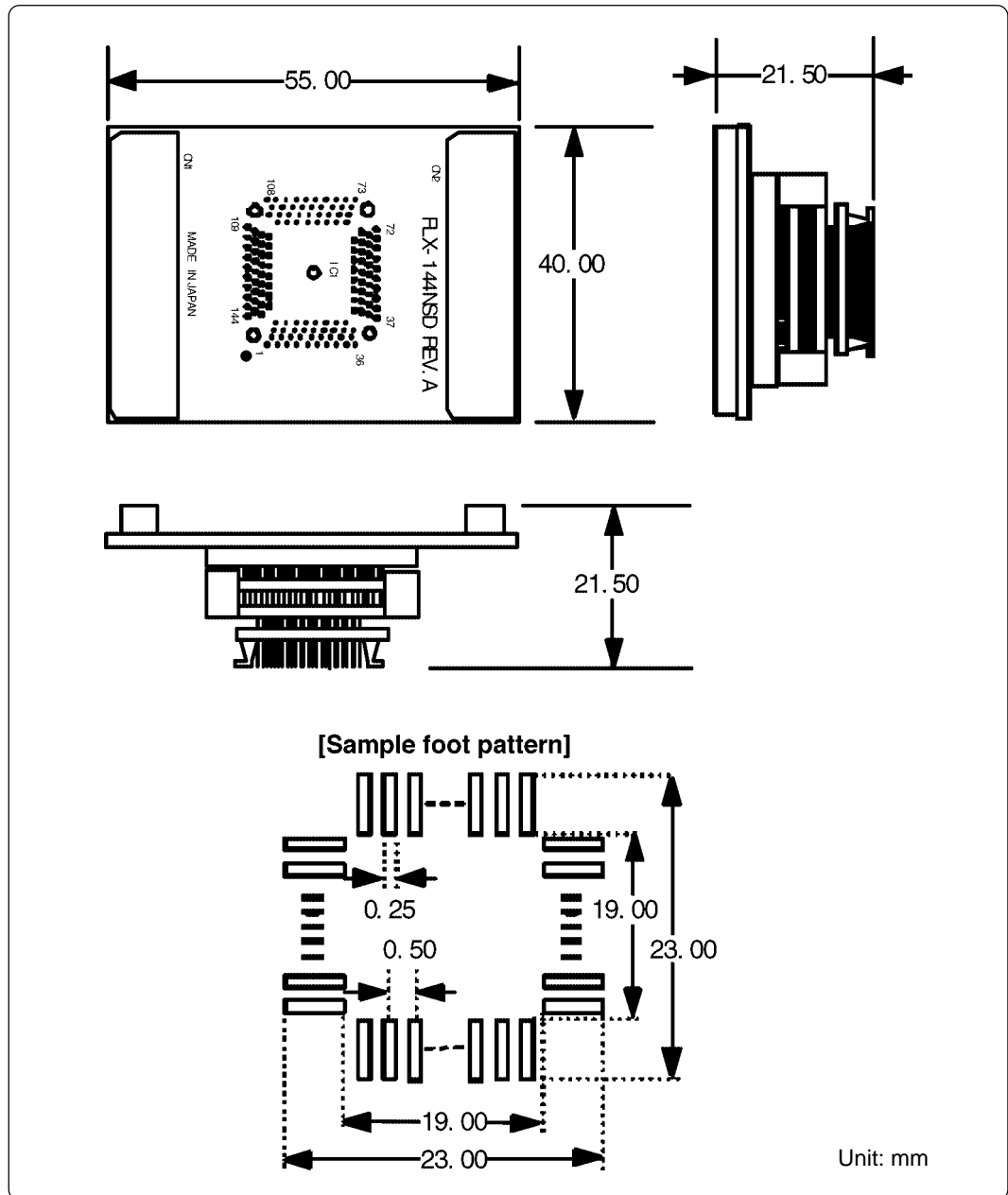

Figure 5.5 External dimensions of converter board (FLX-144NSD)

Chapter 6. Troubleshooting

This chapter describes how to troubleshoot when this product does not work properly.

6.1 Flowchart to Remedy the Troubles	64
6.2 When the Emulator Debugger Does Not Start Up Properly	65
(1) When the LED Display of PC4701 is Abnormal	65
(2) EMEM Dialog is Not Displayed When the Emulator Debugger Starts Up (When the target system is connected)	66
(3) EMEM Dialog is Not Displayed When the Emulator Debugger Starts Up (When the target system is not connected)	67
(4) Errors Occur When the Emulator Debugger Starts Up (When the target system is connected)	67
6.3 Operation Differs from That of Actual MCUs	67
(1) When the A-D Conversion Values are Different from Expected Values	67

Chapter 6. Troubleshooting

6.1 Flowchart to Remedy the Troubles

Figure 6.1 shows the flowchart to remedy the troubles from when power to the emulator is activated until the emulator debugger starts up. Check this while the target system is disconnected. For the latest FAQs visit the following URL.

<http://www.renesas.com/en/tools>

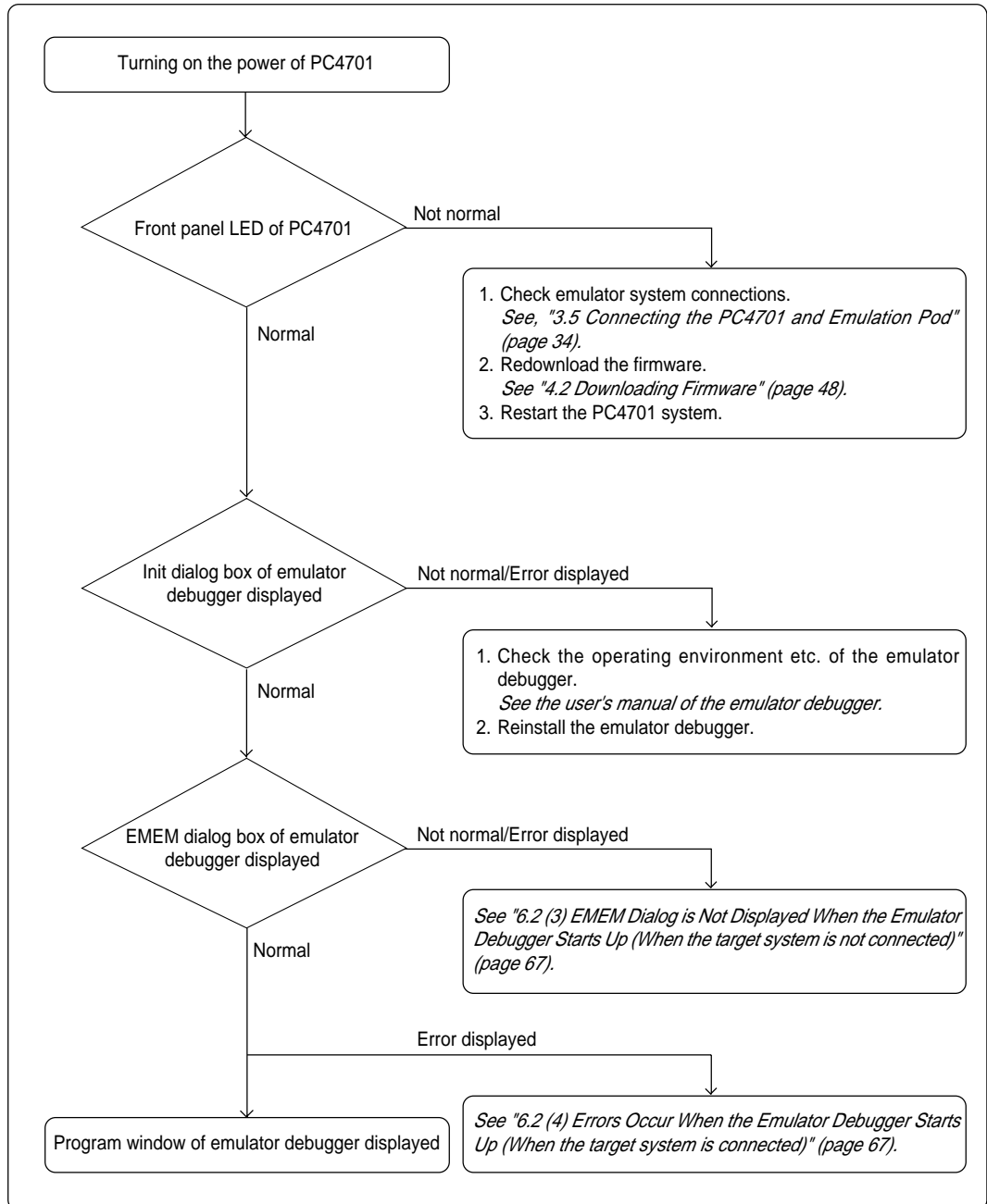

Figure 6.1 Flowchart to remedy the troubles

6.2 When the Emulator Debugger Does Not Start Up Properly

(1) When the LED Display of PC4701 is Abnormal

Table 6.1 LED's abnormal display and its checkpoints

Error	Connection to the target system	Checkpoint
LEDs do not light up.	-	Recheck the power cable is connected to the PC4701. <i>See the instruction manual of the PC4701.</i>
All LEDs remain lit.	-	Recheck the connection between the PC4701 and this product. <i>See "3.5 Connecting the PC4701 and Emulation Pod" (page 34).</i>
The POWER LED of "STATUS OF TARGET" does not light up.	Connected	Check power is properly supplied to the target system and that the target system is properly grounded.
The CLOCK LED of "STATUS OF TARGET" does not light up.	Disconnected	(1) Check that both the main and sub clocks of the emulator debugger are not set to "EXT". <i>See the CLK command of the emulator debugger.</i> (2) Check the oscillation circuit in the emulation pod is oscillating. <i>See "3.3 Selecting Clock Supply" (page 29).</i>
	Connected	(1) Check the oscillation circuit in the target system is oscillating. (2) Check the switches in the emulation pod are correctly set. <i>See "3.2 Switch Settings" (page 25).</i>
The RESET LED of "STATUS OF TARGET" does not go out.	Connected	Check if the reset pin of the target system is pulled up.

**(2) EMEM Dialog is Not Displayed When the Emulator Debugger Starts Up
(When the target system is connected)**

Table 6.2 Checkpoints of errors when starting up the emulator debugger (target is connected)

Error	Checkpoint
Communication error occurred. Data was not sent to the target.	Check all emulator debugger settings, interface cable settings and switches on the rear of the PC4701 match. <i>See the instruction manuals of the PC4701 and emulator debugger.</i>
Target system cannot be properly built.	(1) Download the proper firmware. <i>See "4.2 Downloading Firmware" (page 48).</i> (2) Recheck the connection between the PC4701 and this product. <i>See "3.5 Connecting the PC4701 and Emulation Pod" (page 34).</i>
PD308 version is not the same version as the firmware in the target.	Download the proper firmware. <i>See "4.2 Downloading Firmware" (page 48).</i>
Target MCU is in the reset state.	(1) Check if the reset pin of the target system is pulled up. (2) Check if the reset pin of the target system has changed from "L" to "H" level.
Target MCU cannot be reset.	(1) Check the NMI* pin is "H" level. (2) If in memory expansion mode or microprocessor mode, check the RDY* pin and HOLD* pin are "H" level. (3) If the reset circuit of the target system has a watchdog timer, disable the timer. (4) Check power is properly supplied to the target system and that the target system is properly grounded. (5) The program may be uncontrollable in areas where memory is not allocated. Recheck the map setting. <i>See "4.3 Starting Up the Emulator Debugger (Setting EMEM Dialog)" (page 49).</i>
Target is in "HOLD" state.	(1) The MCU is either in the stop mode or wait mode. Either reset the MCU or cancel the mode with an interrupt. <i>See MCU specifications.</i> (2) The program may be uncontrollable in areas where memory is not allocated. Recheck the map setting. <i>See "4.3 Starting Up the Emulator Debugger (Setting EMEM Dialog)" (page 49).</i>
Target clock is stopped.	(1) Check the oscillation circuit of the target system is oscillating properly. (2) Check the switches in the emulation pod are correctly set. <i>See "3.2 Switch Settings" (page 25).</i>
Target MCU is not receiving power.	Check power is properly supplied to the target system and that the target system is properly grounded.

(3) EMEM Dialog is Not Displayed When the Emulator Debugger Starts Up (When the target system is not connected)

Table 6.3 Checkpoints of errors when starting up the emulator debugger (target is not connected)

Error	Checkpoint
Communication error occurred. Data was not sent to the target.	Check all emulator debugger settings, interface cable settings and switches on the rear of the PC4701 match. <i>See the instruction manuals of the PC4701 and emulator debugger.</i>
Target system cannot be properly built.	(1) Download the proper firmware. <i>See "4.2 Downloading Firmware" (page 48).</i> (2) Recheck the connection between the PC4701 and this product. <i>See "3.5 Connecting the PC4701 and Emulation Pod" (page 34).</i>
PD308 version is not the same version as the firmware in the target.	Download the proper firmware. <i>See "4.2 Downloading Firmware" (page 48).</i>
Target MCU cannot be reset.	The program may be uncontrollable in areas where memory is not allocated. Recheck the map setting. <i>See "4.3 Starting Up the Emulator Debugger (Setting EMEM Dialog)" (page 49).</i>
Target is in HOLD state.	(1) The MCU is either in the stop mode or wait mode. Either reset the MCU or cancel the mode with an interrupt. <i>See MCU specifications.</i> (2) The program may be uncontrollable in areas where memory is not allocated. Recheck the map setting <i>See "4.3 Starting Up the Emulator Debugger (Setting EMEM Dialog)" (page 49).</i>
Target clock is stopped.	Check the switches in the emulation pod are correctly set. <i>See "3.2 Switch Settings" (page 25).</i>

(4) Errors Occur When the Emulator Debugger Starts Up (When the target system is connected)

Table 6.4 Checkpoints of errors when starting up the emulator debugger (target is connected)

Error	Checkpoint
Target MCU is uncontrollable.	(1) Check the NMI* pin is "H" level. (2) If in memory expansion mode or microprocessor mode, check the RDY* pin and HOLD* pin are "H" level. (3) The program may be uncontrollable in areas where memory is not allocated. Recheck the map setting. <i>See "4.3 Starting Up the Emulator Debugger (Setting EMEM Dialog)" (page 49).</i>

6.3 Operation Differs from That of Actual MCUs

(1) When the A-D Conversion Values are Different from Expected Values

Because a flexible board and other devices are used between the evaluation MCU and the target system, the A-D converter operates differently from the actual MCU. Make the final evaluation of the A-D converter from the actual MCU.

MEMO

Chapter 7. Maintenance and Guarantee

This chapter describes how to maintenance, repair provisions and how to request for repair.

7.1 Maintenance	70
7.2 Guarantee	70
7.3 Repair Provisions.....	70
7.4 How to Request for Repair	71

Chapter 7. Maintenance and Guarantee

7.1 Maintenance

If dust or dirt collects on any equipment of your emulation system, wipe it off with a dry soft cloth. Do not use thinner or other solvents because these chemicals can cause the equipment's surface coating to separate.

7.2 Guarantee

If your product becomes faulty within twelve months after its purchase while being used under good conditions by observing "Precautions for Safety" described in Chapter 1 of this user's manual, we will repair or replace your faulty product free of charge. Note, however, that if your product's fault is raised by any one of the following causes, we will repair it or replace it with new one with extra-charge:

- Misuse, abuse, or use under extraordinary conditions
- Unauthorized repair, remodeling, maintenance, and so on
- Inadequate user's system or misuse of it
- Fires, earthquakes, and other unexpected disasters

In the above cases, contact your local distributor. If your product is being leased, consult the leasing company or the owner.

7.3 Repair Provisions

(1) Repair with extra-charge

The products elapsed more than twelve months after purchase can be repaired with extra-charge.

(2) Replacement with extra-charge

If your product's fault falls in any of the following categories, the fault will be corrected by replacing the entire product instead of repair, or you will be advised to purchase new one, depending on the severity of the fault.

- Faulty or broken mechanical portions
- Flaw, separation, or rust in coated or plated portions
- Flaw or cracks in plastic portions
- Faults or breakage caused by improper use or unauthorized repair or modification
- Heavily damaged electric circuits due to overvoltage, overcurrent or shorting of power supply
- Cracks in the printed circuit board or burnt-down patterns
- Wide range of faults that makes replacement less expensive than repair
- Unlocatable or unidentified faults

(3) Expiration of the repair period

When a period of twelve months elapses after the model was dropped from production, repairing products of the model may become impossible.

(4) Transportation fees at sending your product for repair

Please send your product to us for repair at your expense.

7.4 How to Request for Repair

If your product is found faulty, follow the procedure below to send your product for repair.

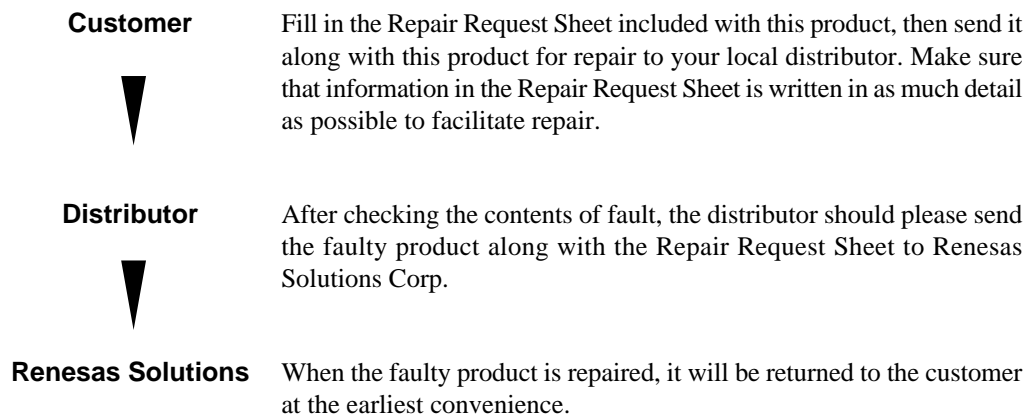

CAUTION

Note on Transporting the Product:



- When sending your product for repair, use the packing box and cushion material supplied with this product when delivered to you and specify handling caution for it to be handled as precision equipment. If packing of your product is not complete, it may be damaged during transportation. When you pack your product in a bag, make sure to use conductive polyvinyl supplied with this product (usually a blue bag). When you use other bags, they may cause a trouble on your product because of static electricity.

MEMO

M30803T-RPD-E User's Manual

Rev. 1.00
July 1, 2003
REJ10J0197-0100Z

COPYRIGHT ©2003 RENESAS TECHNOLOGY CORPORATION
AND RENESAS SOLUTIONS CORPORATION ALL RIGHTS RESERVED

M30803T-RPD-E
User's Manual



Renesas Electronics Corporation

1753, Shimonumabe, Nakahara-ku, Kawasaki-shi, Kanagawa 211-8668 Japan

REJ10J0197-0100Z