

ISL97682IRTZEVALZ

ISL97682 LED Driver Evaluation Board User Manual

AN1662
Rev 0.00
October 11, 2011

Introduction

The ISL97682IRTZEVALZ Evaluation Board provides a complete testing platform for the ISL97682, a two channel LED driver. Please refer to the product datasheet (ISL97682, [FN7689](#)) for detailed information including pinout, pin function description, electrical specifications, applications related information, etc.

Instructions

Please follow the steps described below to start your evaluation.

1. For both switch #1 and #2 (SW1 and SW2 shown on the board), set them to position 3 (left side).
2. For enable control jumper JP1, put the shunt to the "ON" position (right side) to connect EN pin to VIN. When the shunt is set to the "OFF" position, it will disable the chip by pulling the EN pin to ground.
3. Connect JP14 so the VIN pin is connected to PVIN.
4. For JP20, connect the shunt to the upper position.
5. Connect WR and JP2-JP6.
6. Apply 1.5V~5.5V PWM signal between PWMI pin and AGND.
7. Apply 4V~26.5V between PVIN and PGND and the LEDs should be lit, and you can start the evaluation.

NOTE: In step #1 above, the SW1, SW2 position can be adjusted to different positions for different configurations, see Table 1 for details.

TABLE 1.

SW1 POSITION	SW2 POSITION	DESCRIPTION
1	1	LX switching frequency = 600kHz, PFM CH1 and CH3
3	3	LX switching frequency = 1MHz, PFM CH1 and CH3
3	1	LX switching frequency = 600kHz, No PFM CH1 and CH3
1	3	LX switching frequency = 1MHz, No PFM CH1 and CH3

- The LED maximum DC current adjustment.
For each channel, the maximum DC current is set by resistance connected to RSET pin. The current for each channel can be calculated as shown in Equation 1:

$$I_{LED}(mA) = \frac{402}{RSET(k\Omega)} \quad (EQ. 1)$$

On the board, a potentiometer R5 and a few other resistors are provided for easily adjust the LED maximum DC current.

Please refer to the "ISL97682IRTZEVALZ Evaluation Board Schematic" on page 2 for more details.

- LED dimming frequency and duty cycle.
 - As mentioned in step #4 above, when the shunt on JP20 is connected to the upper position, FPWM/DPWM pin is connected to VDC, the device enters direct PWM mode, which means both the LED dimming frequency and the duty cycle are synchronized with the external PWM signal applied on the PWMI pin.
 - When the shunt on JP20 is connected to the lower position, the FPWM/DPWM pin is connected to a resistor. Under such conditions, the LED dimming frequency of the chip is programmed by the resistance connected on the FPWM/DPWM pin as per Equation 2:

$$FPWM(Hz) = 12.4 \cdot \frac{10^7}{R_{FPWM}(\Omega)} \quad (EQ. 2)$$

The duty cycle is still modulated by the external PWM signal applied on PWMI pin. On board, potentiometer R11 and a few other resistors are provided for easily adjusting the LED dimming frequency under such a configuration.

ISL97682IRTZEVALZ Evaluation Board Schematic

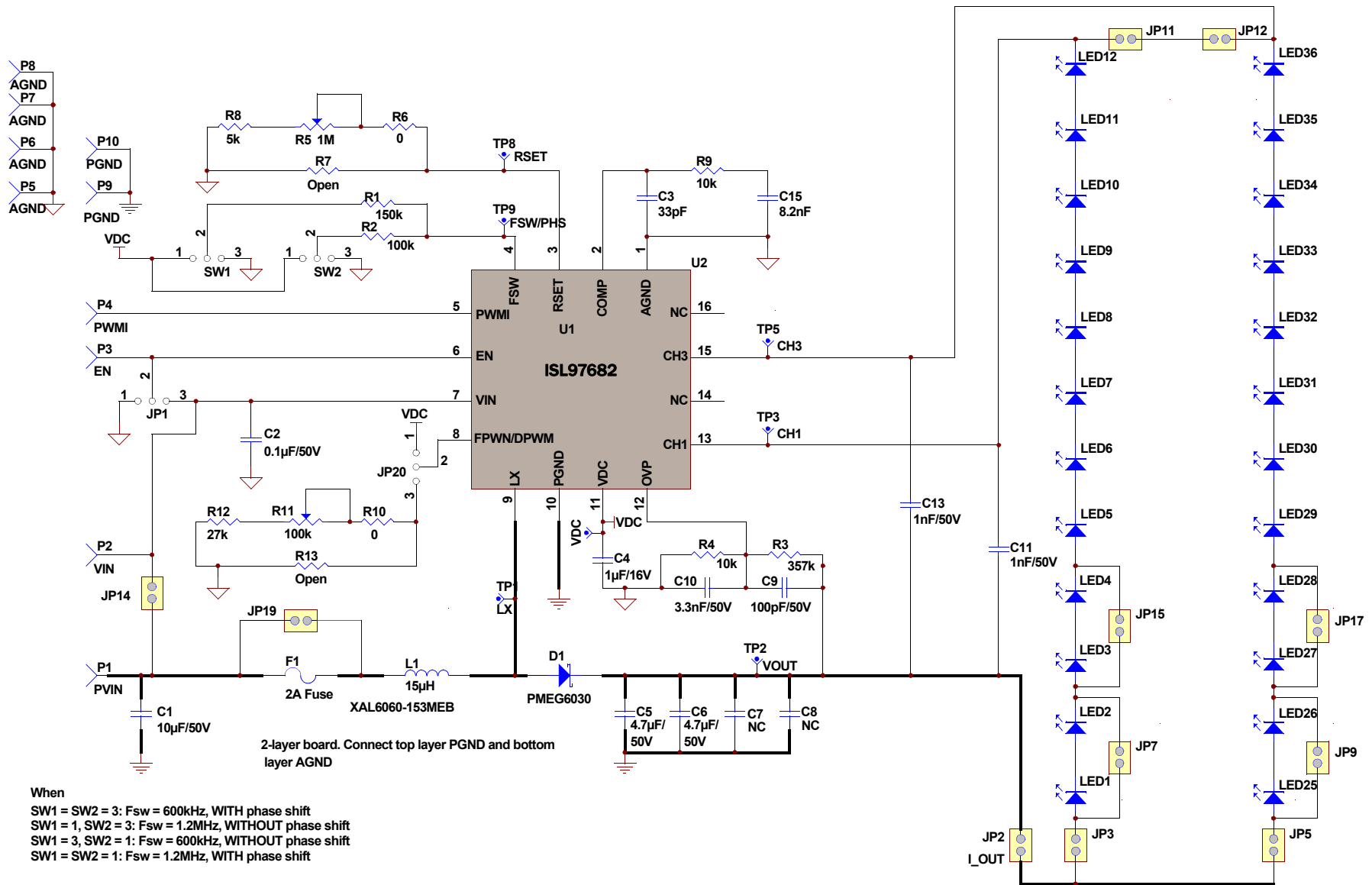

When

- SW1 = SW2 = 3: Fsw = 600kHz, WITH phase shift
- SW1 = 1, SW2 = 3: Fsw = 1.2MHz, WITHOUT phase shift
- SW1 = 3, SW2 = 1: Fsw = 600kHz, WITHOUT phase shift
- SW1 = SW2 = 1: Fsw = 1.2MHz, WITH phase shift

EN can be connected in the following ways to enable/disable the device:

- (1) Connected it to VIN directly on JP1 to enable
- (2) Connected it to GND directly on JP1 to disable
- (3) Directly apply external voltage on P3(EN) to enable/disable the device without putting shunt on JP1.

JP2: For measuring total output current

JP3-JP6: For measuring current on CH1-CH4 respectively

JP7-JP10, JP13-JP16: For easy configuration of 8x LED or 10x LED per string

PCB Layout

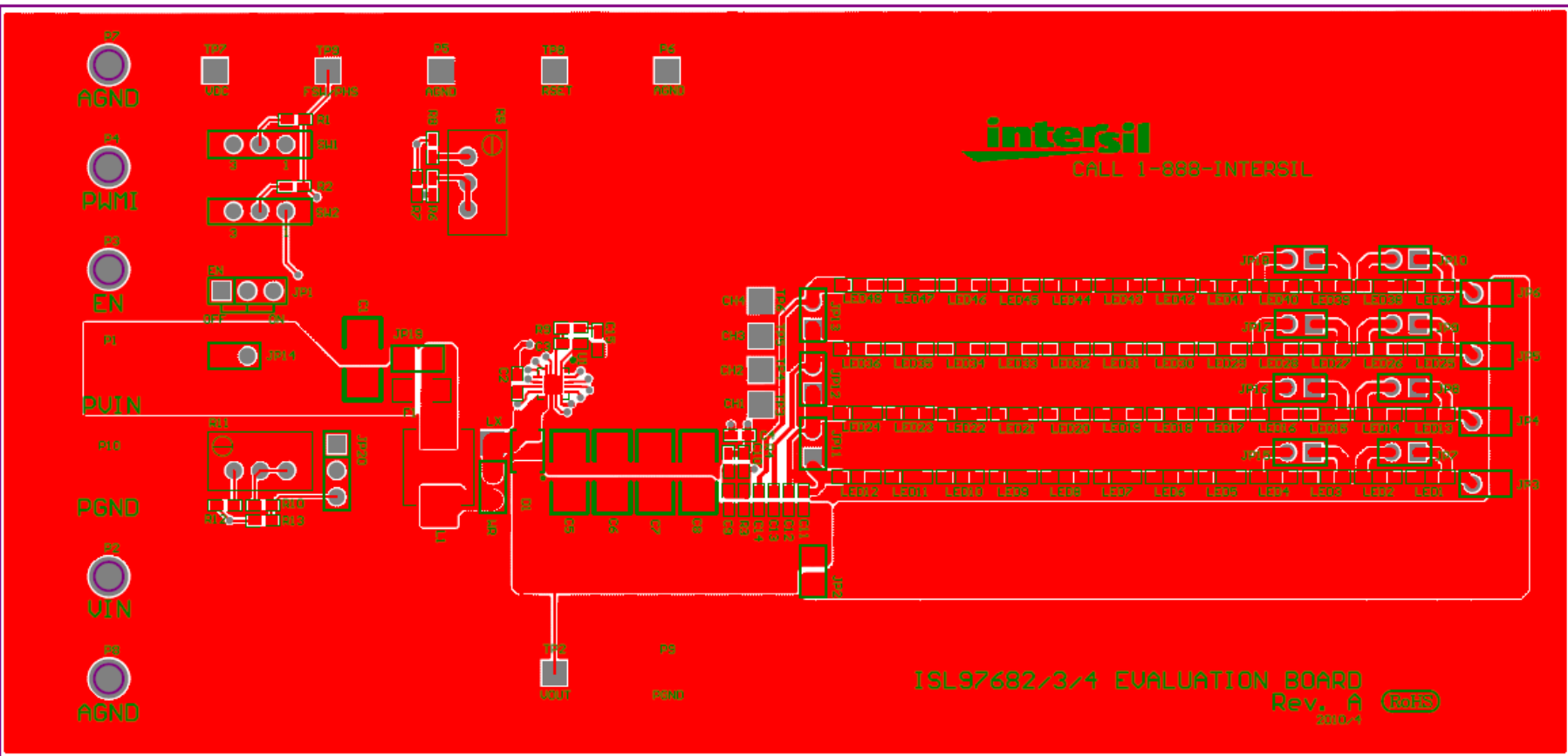

FIGURE 1. TOP SILKSCREEN LAYER + TOP LAYER

PCB Layout (Continued)

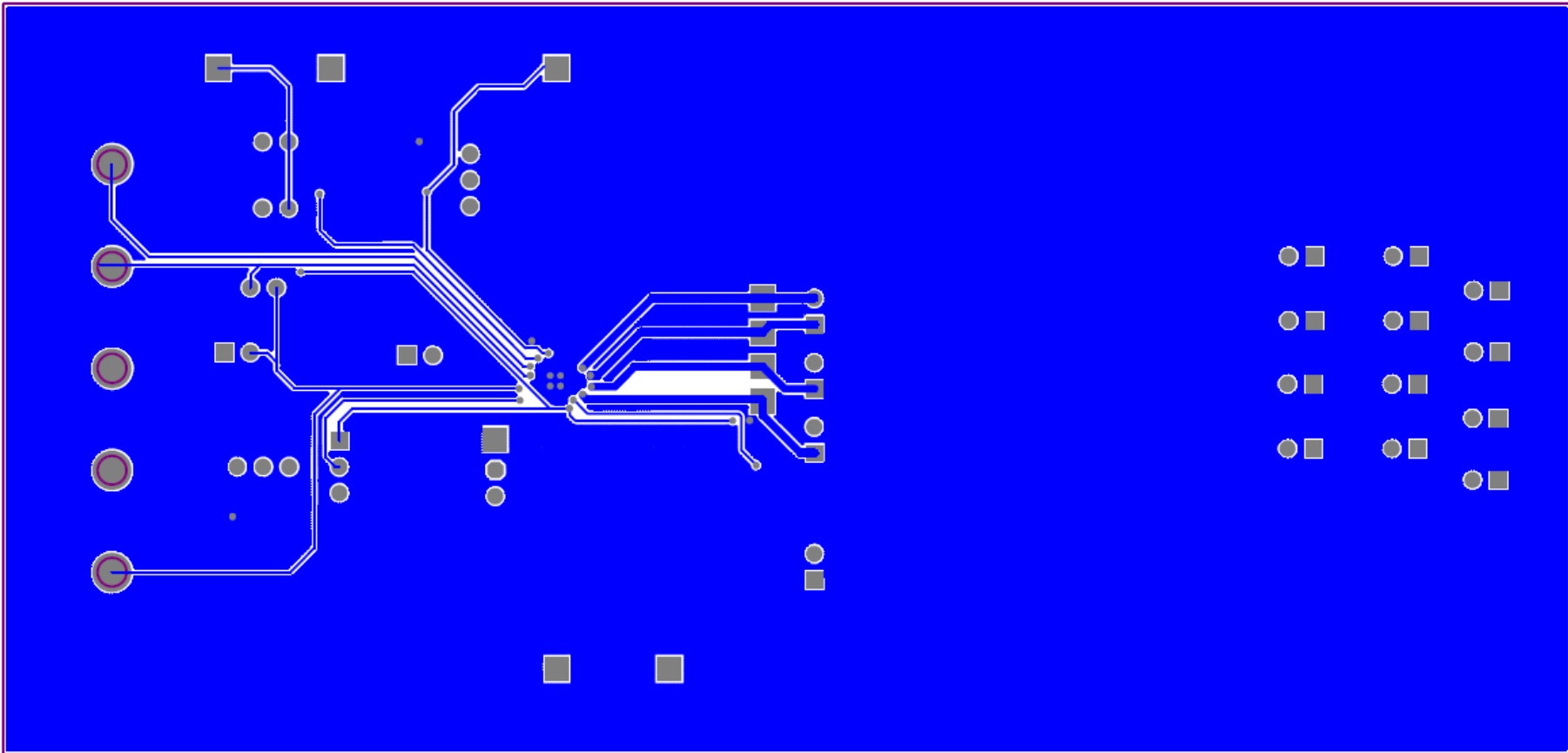

FIGURE 2. BOTTOM LAYER

Bill of Materials (BOM)

DESIGNATOR	PART TYPE	FOOTPRINT	PART MANUFACTURER/NUMBER
R1	150k	603	1% SMD Resistor General purpose
R2	100k	603	
R3	357k	603	
R4	10k	603	
R5	1M	VRES	
R6	open		
R7	38.3k	603	
R8	5k	603	
R9	10k	603	
R10	0	603	
R11	100k	VRES	
R12	0	603	
R13	Open	603	
L1	15 μ H		CoilCraft (XAL6060-153MEB)
D1	PMEG6030		
C1	10 μ F/35V	1210	General purpose Ceramic X5R/X7R capacitors
C2	0.1 μ F/50V	603	
C3	33pF	603	
C4	1 μ F/16V	603	
C5	4.7 μ F/50V	1210	Murata, GRM32ER71H475KA88L
C6	4.7 μ F/50V	1210	
C7	Place Holder	1210	Not Populated
C8	Place Holder	1210	
C9	100pF/50V	603	General purpose Ceramic X5R/X7R capacitors
C10	3.3nF/50V	603	
C11	1nF/50V	603	
C12	Place Holder	603	
C13	1nF/50V	603	
C14	Place Holder	603	
C15	8.2nF	603	
F1	2A Fuse	1206	Bel Fuse Inc, C1Q 2
U1		QFN16 3MM	Intersil, ISL97682/3/4
JP2-JP19	JUMPER-2PIN	JUMPER-2PIN	FCI 68000-236HLF-1x2
WR	JUMPER-2PIN	JUMPER-2PIN	
JP1	JUMPER-3PIN	JUMPER-3PIN	FCI 68000-236HLF-1x3
JP20	JUMPER-3PIN	JUMPER-3PIN	
LED1-12 LED25-36	LED-SMT	LW_Y87C	

Bill of Materials (BOM) (Continued)

DESIGNATOR	PART TYPE	FOOTPRINT	PART MANUFACTURER/NUMBER
TP1	LX	TEST POINT	Keystone Electronics 5010
TP2	VOUT	TEST POINT	
TP3	CH1	TEST POINT	
TP4	CH2	TEST POINT	
TP5	CH3	TEST POINT	
TP6	CH4	TEST POINT	
TP7	VDC	TEST POINT	
TP8	RSET	TEST POINT	
TP9	FSW/PHS	TEST POINT	
P5	AGND	TEST POINT	Keystone Electronics 5011
P6	AGND	TEST POINT	
P9	PGND	TEST POINT	
P1	PVIN	POWERPOST	Mill Max 3156-1-00-00-00-00-08-0
P2	VIN	POWERPOST	
P3	EN	POWERPOST	
P4	PWMI	POWERPOST	
P7	AGND	POWERPOST	
P8	AGND	POWERPOST	
P10	PGND	POWERPOST	
SW2	SPDT	SWITCH-SLIDE-SPDT	EAO 09.03201.02
SW1	SPDT	SWITCH-SLIDE-SPDT	

Notice

1. Descriptions of circuits, software and other related information in this document are provided only to illustrate the operation of semiconductor products and application examples. You are fully responsible for the incorporation or any other use of the circuits, software, and information in the design of your product or system. Renesas Electronics disclaims any and all liability for any losses and damages incurred by you or third parties arising from the use of these circuits, software, or information.
2. Renesas Electronics hereby expressly disclaims any warranties against and liability for infringement or any other claims involving patents, copyrights, or other intellectual property rights of third parties, by or arising from the use of Renesas Electronics products or technical information described in this document, including but not limited to, the product data, drawings, charts, programs, algorithms, and application examples.
3. No license, express, implied or otherwise, is granted hereby under any patents, copyrights or other intellectual property rights of Renesas Electronics or others.
4. You shall not alter, modify, copy, or reverse engineer any Renesas Electronics product, whether in whole or in part. Renesas Electronics disclaims any and all liability for any losses or damages incurred by you or third parties arising from such alteration, modification, copying or reverse engineering.
5. Renesas Electronics products are classified according to the following two quality grades: "Standard" and "High Quality". The intended applications for each Renesas Electronics product depends on the product's quality grade, as indicated below.
"Standard": Computers; office equipment; communications equipment; test and measurement equipment; audio and visual equipment; home electronic appliances; machine tools; personal electronic equipment; industrial robots; etc.
"High Quality": Transportation equipment (automobiles, trains, ships, etc.); traffic control (traffic lights); large-scale communication equipment; key financial terminal systems; safety control equipment; etc.
Unless expressly designated as a high reliability product or a product for harsh environments in a Renesas Electronics data sheet or other Renesas Electronics document, Renesas Electronics products are not intended or authorized for use in products or systems that may pose a direct threat to human life or bodily injury (artificial life support devices or systems; surgical implantations; etc.), or may cause serious property damage (space system; undersea repeaters; nuclear power control systems; aircraft control systems; key plant systems; military equipment; etc.). Renesas Electronics disclaims any and all liability for any damages or losses incurred by you or any third parties arising from the use of any Renesas Electronics product that is inconsistent with any Renesas Electronics data sheet, user's manual or other Renesas Electronics document.
6. When using Renesas Electronics products, refer to the latest product information (data sheets, user's manuals, application notes, "General Notes for Handling and Using Semiconductor Devices" in the reliability handbook, etc.), and ensure that usage conditions are within the ranges specified by Renesas Electronics with respect to maximum ratings, operating power supply voltage range, heat dissipation characteristics, installation, etc. Renesas Electronics disclaims any and all liability for any malfunctions, failure or accident arising out of the use of Renesas Electronics products outside of such specified ranges.
7. Although Renesas Electronics endeavors to improve the quality and reliability of Renesas Electronics products, semiconductor products have specific characteristics, such as the occurrence of failure at a certain rate and malfunctions under certain use conditions. Unless designated as a high reliability product or a product for harsh environments in a Renesas Electronics data sheet or other Renesas Electronics document, Renesas Electronics products are not subject to radiation resistance design. You are responsible for implementing safety measures to guard against the possibility of bodily injury, injury or damage caused by fire, and/or danger to the public in the event of a failure or malfunction of Renesas Electronics products, such as safety design for hardware and software, including but not limited to redundancy, fire control and malfunction prevention, appropriate treatment for aging degradation or any other appropriate measures. Because the evaluation of microcomputer software alone is very difficult and impractical, you are responsible for evaluating the safety of the final products or systems manufactured by you.
8. Please contact a Renesas Electronics sales office for details as to environmental matters such as the environmental compatibility of each Renesas Electronics product. You are responsible for carefully and sufficiently investigating applicable laws and regulations that regulate the inclusion or use of controlled substances, including without limitation, the EU RoHS Directive, and using Renesas Electronics products in compliance with all these applicable laws and regulations. Renesas Electronics disclaims any and all liability for damages or losses occurring as a result of your noncompliance with applicable laws and regulations.
9. Renesas Electronics products and technologies shall not be used for or incorporated into any products or systems whose manufacture, use, or sale is prohibited under any applicable domestic or foreign laws or regulations. You shall comply with any applicable export control laws and regulations promulgated and administered by the governments of any countries asserting jurisdiction over the parties or transactions.
10. It is the responsibility of the buyer or distributor of Renesas Electronics products, or any other party who distributes, disposes of, or otherwise sells or transfers the product to a third party, to notify such third party in advance of the contents and conditions set forth in this document.
11. This document shall not be reprinted, reproduced or duplicated in any form, in whole or in part, without prior written consent of Renesas Electronics.
12. Please contact a Renesas Electronics sales office if you have any questions regarding the information contained in this document or Renesas Electronics products.
(Note 1) "Renesas Electronics" as used in this document means Renesas Electronics Corporation and also includes its directly or indirectly controlled subsidiaries.
(Note 2) "Renesas Electronics product(s)" means any product developed or manufactured by or for Renesas Electronics.

(Rev.4.0-1 November 2017)



SALES OFFICES

Renesas Electronics Corporation

<http://www.renesas.com>

Refer to "<http://www.renesas.com/>" for the latest and detailed information.

Renesas Electronics America Inc.
1001 Murphy Ranch Road, Milpitas, CA 95035, U.S.A.
Tel: +1-408-432-8888, Fax: +1-408-434-5351

Renesas Electronics Canada Limited
9251 Yonge Street, Suite 8309 Richmond Hill, Ontario Canada L4C 9T3
Tel: +1-905-237-2004

Renesas Electronics Europe Limited
Dukes Meadow, Millboard Road, Bourne End, Buckinghamshire, SL8 5FH, U.K
Tel: +44-1628-651-700, Fax: +44-1628-651-804

Renesas Electronics Europe GmbH
Arcadiastrasse 10, 40472 Düsseldorf, Germany
Tel: +49-211-6503-0, Fax: +49-211-6503-1327

Renesas Electronics (China) Co., Ltd.
Room 1709 Quantum Plaza, No.27 ZhichunLu, Haidian District, Beijing, 100191 P. R. China
Tel: +86-10-8235-1155, Fax: +86-10-8235-7679

Renesas Electronics (Shanghai) Co., Ltd.
Unit 301, Tower A, Central Towers, 555 Langao Road, Putuo District, Shanghai, 200333 P. R. China
Tel: +86-21-2226-0888, Fax: +86-21-2226-0999

Renesas Electronics Hong Kong Limited
Unit 1601-1611, 16/F., Tower 2, Grand Century Place, 193 Prince Edward Road West, Mongkok, Kowloon, Hong Kong
Tel: +852-2265-6688, Fax: +852-2886-9022

Renesas Electronics Taiwan Co., Ltd.
13F, No. 363, Fu Shing North Road, Taipei 10543, Taiwan
Tel: +886-2-8175-9600, Fax: +886-2-8175-9670

Renesas Electronics Singapore Pte. Ltd.
80 Bendemeer Road, Unit #06-02 Hyflux Innovation Centre, Singapore 339949
Tel: +65-6213-0200, Fax: +65-6213-0300

Renesas Electronics Malaysia Sdn.Bhd.
Unit 1207, Block B, Menara Amcorp, Amcorp Trade Centre, No. 18, Jln Persiaran Barat, 46050 Petaling Jaya, Selangor Darul Ehsan, Malaysia
Tel: +60-3-7955-9390, Fax: +60-3-7955-9510

Renesas Electronics India Pvt. Ltd.
No.777C, 100 Feet Road, HAL 2nd Stage, Indiranagar, Bangalore 560 038, India
Tel: +91-80-67208700, Fax: +91-80-67208777

Renesas Electronics Korea Co., Ltd.
17F, KAMCO Yangjae Tower, 262, Gangnam-daero, Gangnam-gu, Seoul, 06265 Korea
Tel: +82-2-558-3737, Fax: +82-2-558-5338