



IE850A Emulator

RTE0T0850AKCT00000J

User's Manual

All information contained in these materials, including products and product specifications, represents information on the product at the time of publication and is subject to change by Renesas Electronics Corp. without notice. Please review the latest information published by Renesas Electronics Corp. through various means, including the Renesas Electronics Corp. website (<http://www.renesas.com>).

Notice

1. Descriptions of circuits, software and other related information in this document are provided only to illustrate the operation of semiconductor products and application examples. You are fully responsible for the incorporation or any other use of the circuits, software, and information in the design of your product or system. Renesas Electronics disclaims any and all liability for any losses and damages incurred by you or third parties arising from the use of these circuits, software, or information.
2. Renesas Electronics hereby expressly disclaims any warranties against and liability for infringement or any other claims involving patents, copyrights, or other intellectual property rights of third parties, by or arising from the use of Renesas Electronics products or technical information described in this document, including but not limited to, the product data, drawings, charts, programs, algorithms, and application examples.
3. No license, express, implied or otherwise, is granted hereby under any patents, copyrights or other intellectual property rights of Renesas Electronics or others.
4. You shall be responsible for determining what licenses are required from any third parties, and obtaining such licenses for the lawful import, export, manufacture, sales, utilization, distribution or other disposal of any products incorporating Renesas Electronics products, if required.
5. You shall not alter, modify, copy, or reverse engineer any Renesas Electronics product, whether in whole or in part. Renesas Electronics disclaims any and all liability for any losses or damages incurred by you or third parties arising from such alteration, modification, copying or reverse engineering.
6. Renesas Electronics products are classified according to the following two quality grades: "Standard" and "High Quality". The intended applications for each Renesas Electronics product depends on the product's quality grade, as indicated below.
 - "Standard": Computers; office equipment; communications equipment; test and measurement equipment; audio and visual equipment; home electronic appliances; machine tools; personal electronic equipment; industrial robots; etc.
 - "High Quality": Transportation equipment (automobiles, trains, ships, etc.); traffic control (traffic lights); large-scale communication equipment; key financial terminal systems; safety control equipment; etc.
- Unless expressly designated as a high reliability product or a product for harsh environments in a Renesas Electronics data sheet or other Renesas Electronics document, Renesas Electronics products are not intended or authorized for use in products or systems that may pose a direct threat to human life or bodily injury (artificial life support devices or systems; surgical implantations; etc.), or may cause serious property damage (space system; undersea repeaters; nuclear power control systems; aircraft control systems; key plant systems; military equipment; etc.). Renesas Electronics disclaims any and all liability for any damages or losses incurred by you or any third parties arising from the use of any Renesas Electronics product that is inconsistent with any Renesas Electronics data sheet, user's manual or other Renesas Electronics document.
7. No semiconductor product is absolutely secure. Notwithstanding any security measures or features that may be implemented in Renesas Electronics hardware or software products, Renesas Electronics shall have absolutely no liability arising out of any vulnerability or security breach, including but not limited to any unauthorized access to or use of a Renesas Electronics product or a system that uses a Renesas Electronics product. RENESAS ELECTRONICS DOES NOT WARRANT OR GUARANTEE THAT RENESAS ELECTRONICS PRODUCTS, OR ANY SYSTEMS CREATED USING RENESAS ELECTRONICS PRODUCTS WILL BE INVULNERABLE OR FREE FROM CORRUPTION, ATTACK, VIRUSES, INTERFERENCE, HACKING, DATA LOSS OR THEFT, OR OTHER SECURITY INTRUSION ("Vulnerability Issues"). RENESAS ELECTRONICS DISCLAIMS ANY AND ALL RESPONSIBILITY OR LIABILITY ARISING FROM OR RELATED TO ANY VULNERABILITY ISSUES. FURTHERMORE, TO THE EXTENT PERMITTED BY APPLICABLE LAW, RENESAS ELECTRONICS DISCLAIMS ANY AND ALL WARRANTIES, EXPRESS OR IMPLIED, WITH RESPECT TO THIS DOCUMENT AND ANY RELATED OR ACCOMPANYING SOFTWARE OR HARDWARE, INCLUDING BUT NOT LIMITED TO THE IMPLIED WARRANTIES OF MERCHANTABILITY, OR FITNESS FOR A PARTICULAR PURPOSE.
8. When using Renesas Electronics products, refer to the latest product information (data sheets, user's manuals, application notes, "General Notes for Handling and Using Semiconductor Devices" in the reliability handbook, etc.), and ensure that usage conditions are within the ranges specified by Renesas Electronics with respect to maximum ratings, operating power supply voltage range, heat dissipation characteristics, installation, etc. Renesas Electronics disclaims any and all liability for any malfunctions, failure or accident arising out of the use of Renesas Electronics products outside of such specified ranges.
9. Although Renesas Electronics endeavors to improve the quality and reliability of Renesas Electronics products, semiconductor products have specific characteristics, such as the occurrence of failure at a certain rate and malfunctions under certain use conditions. Unless designated as a high reliability product or a product for harsh environments in a Renesas Electronics data sheet or other Renesas Electronics document, Renesas Electronics products are not subject to radiation resistance design. You are responsible for implementing safety measures to guard against the possibility of bodily injury, injury or damage caused by fire, and/or danger to the public in the event of a failure or malfunction of Renesas Electronics products, such as safety design for hardware and software, including but not limited to redundancy, fire control and malfunction prevention, appropriate treatment for aging degradation or any other appropriate measures. Because the evaluation of microcomputer software alone is very difficult and impractical, you are responsible for evaluating the safety of the final products or systems manufactured by you.
10. Please contact a Renesas Electronics sales office for details as to environmental matters such as the environmental compatibility of each Renesas Electronics product. You are responsible for carefully and sufficiently investigating applicable laws and regulations that regulate the inclusion or use of controlled substances, including without limitation, the EU RoHS Directive, and using Renesas Electronics products in compliance with all these applicable laws and regulations. Renesas Electronics disclaims any and all liability for damages or losses occurring as a result of your noncompliance with applicable laws and regulations.
11. Renesas Electronics products and technologies shall not be used for or incorporated into any products or systems whose manufacture, use, or sale is prohibited under any applicable domestic or foreign laws or regulations. You shall comply with any applicable export control laws and regulations promulgated and administered by the governments of any countries asserting jurisdiction over the parties or transactions.
12. It is the responsibility of the buyer or distributor of Renesas Electronics products, or any other party who distributes, disposes of, or otherwise sells or transfers the product to a third party, to notify such third party in advance of the contents and conditions set forth in this document.
13. This document shall not be reprinted, reproduced or duplicated in any form, in whole or in part, without prior written consent of Renesas Electronics.
14. Please contact a Renesas Electronics sales office if you have any questions regarding the information contained in this document or Renesas Electronics products.

(Note1) "Renesas Electronics" as used in this document means Renesas Electronics Corporation and also includes its directly or indirectly controlled subsidiaries.

(Note2) "Renesas Electronics product(s)" means any product developed or manufactured by or for Renesas Electronics.

(Rev.5.0-1 October 2020)

Corporate Headquarters

TOYOSU FORESIA, 3-2-24 Toyosu,
Koto-ku, Tokyo 135-0061, Japan

www.renesas.com

Trademarks

Renesas and the Renesas logo are trademarks of Renesas Electronics Corporation. All trademarks and registered trademarks are the property of their respective owners.

Contact information

For further information on a product, technology, the most up-to-date version of a document, or your nearest sales office, please visit:
www.renesas.com/contact/.

Preface

The IE850A is an emulator which supports external tracing (Aurora tracing) for RH850 family MCUs from Renesas Electronics Corporation.

All components that come with the emulation adapter are listed under “1.1 Package Components”. If you have any questions about the emulation adapter, contact your local distributor.

For information on debuggers and related products, please see the user’s manuals, additional documents for user’s manuals, and application notes provided for the individual products.

Related Documents

Name of Document	Document No.
E2 Emulator RTE0T00020KCE00000R User’s Manual	R20UT3538E
E2 Emulator, IE850A Additional Document for User’s Manual (Notes on Connection of RH850/E2x Series)	R20UT4140E
Emulation Adapter for the RH850/E2UH and E2H Groups RTE7702012EAB00000J User’s Manual	R20UT4460E
Emulation Adapter for the RH850/U2A RTE7702200EAB00000J User’s Manual	R20UT4569E
Emulation Adapter for the RH850/U2B RTE7702500EAB00000J, RTE7702500EAB0B000J, RTE7702500EAB0K000J, RTE7702500EAB0L000J User’s Manual	R20UT5180E

Note: The contents of the related documents listed above may be changed without prior notice. Be sure to use the latest versions of the documents, which can be downloaded from “Software and Tools” on the Renesas Web page.

<https://www.renesas.com/>

Important

Before using this product, be sure to read this user's manual carefully.

Keep this user's manual, and refer to it when you have questions about this product.

Purpose of use of this product:

This product is for the support of the development of systems that use RH850-family MCUs from Renesas. It provides support for system development in both software and hardware.

Be sure to use this product correctly according to said purpose of use. Please avoid using this product other than for its intended purpose of use.

For those who use this product:

This product can only be used by those who have carefully read the user's manual and know how to use it.

Use of this product requires basic knowledge of electric circuits, logical circuits, and MCUs.

When using the product:

- (1) This product is a development-support unit for use in your program development and evaluation stages. When a program you have finished developing is to be incorporated in a mass-produced product, the judgment as to whether it can be put to practical use is entirely your own responsibility, and should be based on evaluation of the device on which it is installed and other experiments.
- (2) In no event shall Renesas Electronics Corp. be liable for any consequence arising from the use of this product.
- (3) Renesas Electronics Corp. strives to provide workarounds for and correct trouble with products malfunctions, with some free and some incurring charges. However, this does not necessarily mean that Renesas Electronics Corp. guarantees the provision of a workaround or correction under any circumstances.
- (4) The product covered by this document has been developed on the assumption that it will be used for program development and evaluation in laboratories. Therefore, it does not fall within the scope of applicability of the Electrical Appliance and Material Safety Law and protection against electromagnetic interference when used in Japan.
- (5) Renesas Electronics Corp. cannot predict all possible situations and possible cases of misuse that carry a potential for danger. Therefore, the warnings in this user's manual and the warning labels attached to the product do not necessarily cover all such possible situations and cases. The customer is responsible for correctly and safely using this product.
- (6) The product covered by this document has been through the process of checking conformance with the standards indicated in section 1.5, Regulatory Compliance Notices. This fact must be taken into account when the product is taken from Japan to another country.
- (7) Renesas Electronics Corp. will not assume responsibility for direct or indirect damage caused by an accidental failure or malfunction of this product.

When disposing of the product:

Penalties may be applicable for incorrect disposal of this waste, in accordance with your national legislation.

Usage restrictions:

The product has been developed as a means of supporting system development by users. Therefore, do not use it as an embedded device in other equipment. Also, do not use it to develop systems or equipment for use in the following fields.

- (1) Transportation and vehicular
- (2) Medical (equipment that has an involvement in human life)
- (3) Aerospace
- (4) Nuclear power control
- (5) Undersea repeaters

If you are considering the use of the product for one of the above purposes, please be sure to consult your local distributor.

About product changes:

We are constantly making efforts to improve the design and performance of this product. Therefore, the specification or design of this product, or this user's manual, may be changed without prior notice.

About rights:

- (1) We assume no responsibility for any damage or infringement on patent rights or any other rights arising from the use of any information, products or circuits presented in this user's manual.
- (2) The information or data in this user's manual does not implicitly or otherwise grant a license to patent rights or any other rights belonging to Renesas or to a third party.
- (3) This user's manual and this product are copyrighted, with all rights reserved by Renesas. This user's manual may not be copied, duplicated or reproduced, in whole or part, without prior written consent from Renesas.

About diagrams:

Some diagrams in this user's manual may differ from the objects they represent.

Precautions for Safety

This chapter describes the precautions which should be taken in order to use this product safely and properly. Be sure to read and understand this chapter before using this product. Contact your local distributor if you have any questions about the precautions described here.



WARNING

WARNING indicates a potentially dangerous situation that will cause death or heavy wound unless it is avoided.



CAUTION

CAUTION indicates a potentially dangerous situation that will cause a slight injury or a medium-degree injury unless it is avoided.

CAUTION

CAUTION without a safety warning symbol indicates a potentially dangerous situation that will cause damage to property unless it is avoided.

To avoid a possible danger, the following diagrammatic symbols are used to call your attention.

△ means WARNING or CAUTION.

Example:



CAUTION AGAINST AN ELECTRIC SHOCK

⊘ means PROHIBITION.

Example:



DISASSEMBLY PROHIBITED

● means A FORCIBLE ACTION.

Example:



UNPLUG THE POWER CABLE FROM THE RECEPTACLE.



WARNING

Warnings for AC Power Supply:



Do not repair or remodel the emulator product by yourself in order to prevent danger such as an electric shock or fire and for the sake of quality assurance. For after-sale services in case of a mechanical or electrical fault, please contact your local distributor.

Always switch off the user system before connecting or disconnecting any connectors or cables. Neglecting to take this precaution may result in an electric shock or in this product emitting smoke or catching fire. Also, a user program being debugged may be destroyed.

Make sure that the connectors and cables are connected in the correct directions.

Neglect of this precaution will result in getting an electric shock or will result in this product emitting smoke or catching fire.

Warning for Modification:



Do not modify this product. Personal injury due to electric shock may occur if the product is modified. Modifying the product will void your warranty.

Warning for Installation:



Do not set this product in water or areas of high humidity. Make sure that the product does not get wet. Spilling water or some other liquid into the product may cause un-repairable damage.

Warning for Use Temperature:



This product is to be used in an environment with a maximum ambient temperature of 40°C.

Care should be taken that this temperature is not exceeded.

CAUTION

Cautions to Be Taken for Handling This Product:



Use caution when handling this product. Be careful not to apply a mechanical shock.

Do not operate switches before removing static electricity from the operator's body. Doing so may lead to the discharge of static electricity and so damage the internal circuits. Also, do not directly touch connector pins.

When attaching and removing the cable, hold a fixture (such as a connector) to avoid pulling the cable.

Caution to Be Taken for System Malfunctions:



If this product malfunctions because of interference like external noise, do the following to remedy the trouble.

- (1) Exit the debugger, and turn off the emulator and the target system.
- (2) After a lapse of 10 seconds, turn on the power of this product again, then launch the debugger.

Caution to Be Taken for Disposal:



Penalties may be applicable for incorrect disposal of this waste, in accordance with your national legislation.

European Union Regulatory Notices:



The WEEE (Waste Electrical and Electronic Equipment) regulations put responsibilities on producers for the collection and recycling or disposal of electrical and electronic waste. Return of WEEE under these regulations is applicable in the European Union only. This equipment (including all accessories) is not intended for household use. After use the equipment cannot be disposed of as household waste, and the WEEE must be treated, recycled and disposed of in an environmentally sound manner.

Renesas Electronics Europe GmbH can take back end of life equipment, register for this service at "<http://www.renesas.eu/wEEE>".

Contents

Preface	3
Important	4
Precautions for Safety	6
Contents	9
Terminology	10
1. Outline	11
1.1 Package Components.....	11
1.2 AC Adapter (Sold Separately)	12
1.3 Trace Cable for the IE850A (Sold Separately)	12
1.4 Hardware Specifications	13
1.5 Regulatory Compliance Notices	14
2. Names and Functions of Hardware	16
2.1 IE850A	16
2.2 Trace Cable for the IE850A (Sold Separately)	19
2.3 Power-Supply Cable for the Emulation Adapter	20
3. Setup Procedure.....	22
3.1 Installing the Emulator Software	22
3.2 Connecting the Trace Cable and Power-Supply Cable	22
3.3 Connecting the Target System	23
3.4 Connecting the USB Cable and the AC Adapter	24
3.5 Turning on the IE850A Main Unit.....	24
3.6 Turning on the Target System	24
3.7 Starting the Debugger.....	24
3.8 Shutdown Procedure	24
4. Connecting the IE850A and Target System.....	25
4.1 Emulator Connector for External Tracing	25
4.2 Pin Assignments of the Connector	26
4.3 Examples of Recommended Connections between the Emulator Connector and Target Device.....	27
5. Note	32
5.1 Capacity of Trace Memory.....	32
6. Troubleshooting.....	33
7. Maintenance and Warranty.....	35
7.1 Maintenance	35
7.2 Warranty.....	35
7.3 Repair Provisions.....	35
7.4 How to Request Repairs	36
Revision History.....	37

Terminology

Some specific words used in this user's manual are defined below.

Target device

This means the device to be emulated or debugged.

Debug chip

This means the device that emulates the operation of the target device and implements debugging facilities such as tracing.

Aurora tracing

Aurora is a high-speed communications protocol from Xilinx Inc. The debug chip is capable of using Aurora as a trace interface.

Target system

This means the user-created system which is to be debugged. This includes both hardware and software created by the user.

Emulation adapter

This is a board which emulates the device to be debugged. A debug chip is mounted on the board.

1. Outline

The IE850A is an emulator which supports external tracing (Aurora tracing) for RH850 family MCUs from Renesas Electronics Corporation.

Connecting the IE850A to a target system on which the target device is mounted enables the efficient debugging of hardware and software when developing systems around the target device.

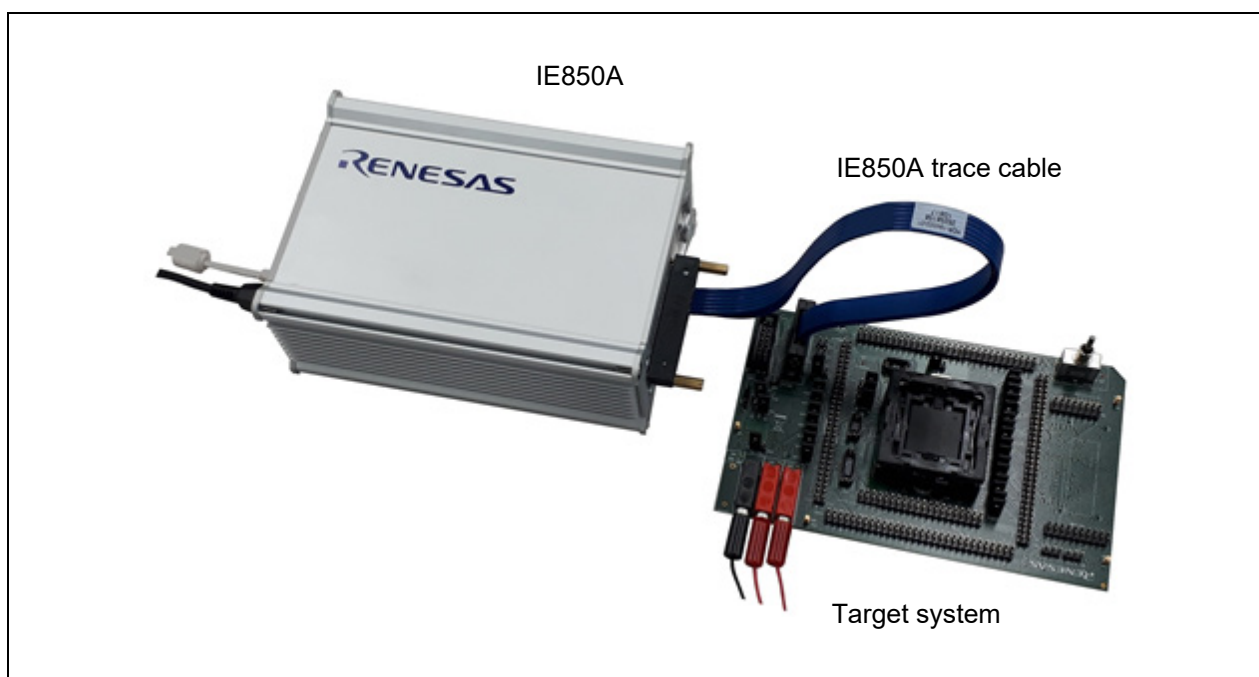

Figure 1-1 External Appearance

1.1 Package Components

The package of this product consists of the following items. After you have unpacked the box, check if your emulation adapter contains all of these items.

Note that the AC adapter and the IE850A trace cable are sold as separate items.

Table 1-1 Package Components for the IE850A

Item	Quantity
IE850A (RTE0T0850AKCT00000J)	1
USB cable	1
Power-supply cable for an emulation adapter	1

1.2 AC Adapter (Sold Separately)

The specifications of the AC adapter for the IE850A depend on the region where it is to be used. Be sure to use the AC adapter that corresponds to the region you are in. The IE850A does not include an AC adapter. The AC adapters for the IE850A are the same as those for the IE850 (QB-V850E2).

Table 1-2 Part Numbers of the AC Adapters for the IE850A Classified by Region

Product	Region	Part Number
AC adapter (sold separately)	Japan	QB-V850E2-PW-JP
	U.S.A.	QB-V850E2-PW-EA
	China	QB-V850E2-PW-CN
	Hong Kong	QB-V850E2-PW-HK
	Korea	QB-V850E2-PW-KR
	Singapore	QB-V850E2-PW-SG
	Europe	QB-V850E2-PW-EE

- Notes:
1. Products are shipped only on order from each region.
 2. Contact a distributor for information on regions other than the above.
 3. Only the AC adapter usable in each region can be ordered.

1.3 Trace Cable for the IE850A (Sold Separately)

You will also need the trace cable for the IE850A to connect it to the target system.

Table 1-3 Part Number of the Trace Cable for the IE850A

Product	Part Number
Trace cable for the IE850A (sold separately)	RTE0T0850AKCAC0000J

1.4 Hardware Specifications

Table 1-4 lists the specifications of hardware.

Table 1-4 Hardware Specifications

Item	Specification
Operating temperature	0 to 40°C (no condensation)
Storage temperature	–15 to 60°C (no condensation)
Power consumed for the AC adapter (sold separately)	15 V, 4 A
External dimension	165.1 mm x 115.7 mm x 67 mm
Weight	Approx. 800 g
Host interface	USB 2.0 (full speed or high speed)
Capacity of trace memory	9 Gbytes
Trace interface	One lane, two lanes, or four lanes 6.25 Gbps/lane (max.) The selectable number of lanes and the communications rate depend on the target device.
EMC	EU: EN55032 Class A, EN55024 USA: FCC part 15 Class A
Power-supply cable for the emulation adapter	Cable length: Approx. 300 mm
Trace cable for the IE850A (sold separately)	Connectable to the ASP-137973-01 connector from SAMTEC. Cable length: Approx. 300 mm

1.5 Regulatory Compliance Notices

- European Union regulatory notices

This product complies with the following EU Directives. (These directives are only valid in the European Union.)

CE Certifications:

This product complies with the following European EMC standards.

- EMC Directive (2014/30/EU)

EN 55032 Class A

WARNING: This is a Class A product. This equipment can cause radio frequency noise when used in the residential area. In such cases, the user/operator of the equipment may be required to take appropriate countermeasures under his responsibility.

EN 55024

Information for traceability:

- Authorised representative & Manufacturer

Name: Renesas Electronics Corporation

Address: TOYOSU FORESIA, 3-2-24, Toyosu, Koto-ku, Tokyo, 135-0061, Japan

- Person responsible for placing on the market

Name: Renesas Electronics Europe GmbH

Address: Arcadiastrasse 10, 40472 Dusseldorf, Germany

- Trademark and Type name

Trademark: Renesas

Product name: IE850A In-circuit emulator

Type name: RTE0T0850AKCT00000J

Environmental Compliance and Certifications:

- Waste Electrical and Electronic Equipment (WEEE) Directive 2012/19/EU

- United States Regulatory notices on Electromagnetic compatibility

This product complies with the following EMC regulation. (This is only valid in the United States.)

FCC Certifications:

This equipment has been tested and found to comply with the limits for a Class A digital device, pursuant to Part 15 of the FCC Rules. These limits are designed to provide reasonable protection against harmful interference when the equipment is operated in a commercial environment. This equipment generates, uses, and can radiate radio frequency energy and, if not installed and used in accordance with the instruction manual, may cause harmful interference to radio communications. Operation of this equipment in a residential area is likely to cause harmful interference in which case the user will be required to correct the interference at his own expense.

This device complies with Part 15 of the FCC Rules. Operation is subject to the following two conditions: (1) this device may not cause harmful interference, and (2) this device must accept any interference received, including interference that may cause undesired operation.

CAUTION: Changes or modifications not expressly approved by the party responsible for compliance could void the user's authority to operate the equipment.

2. Names and Functions of Hardware

This chapter describes the names and functions of hardware.

2.1 IE850A

The IE850A is an emulator which supports external tracing.

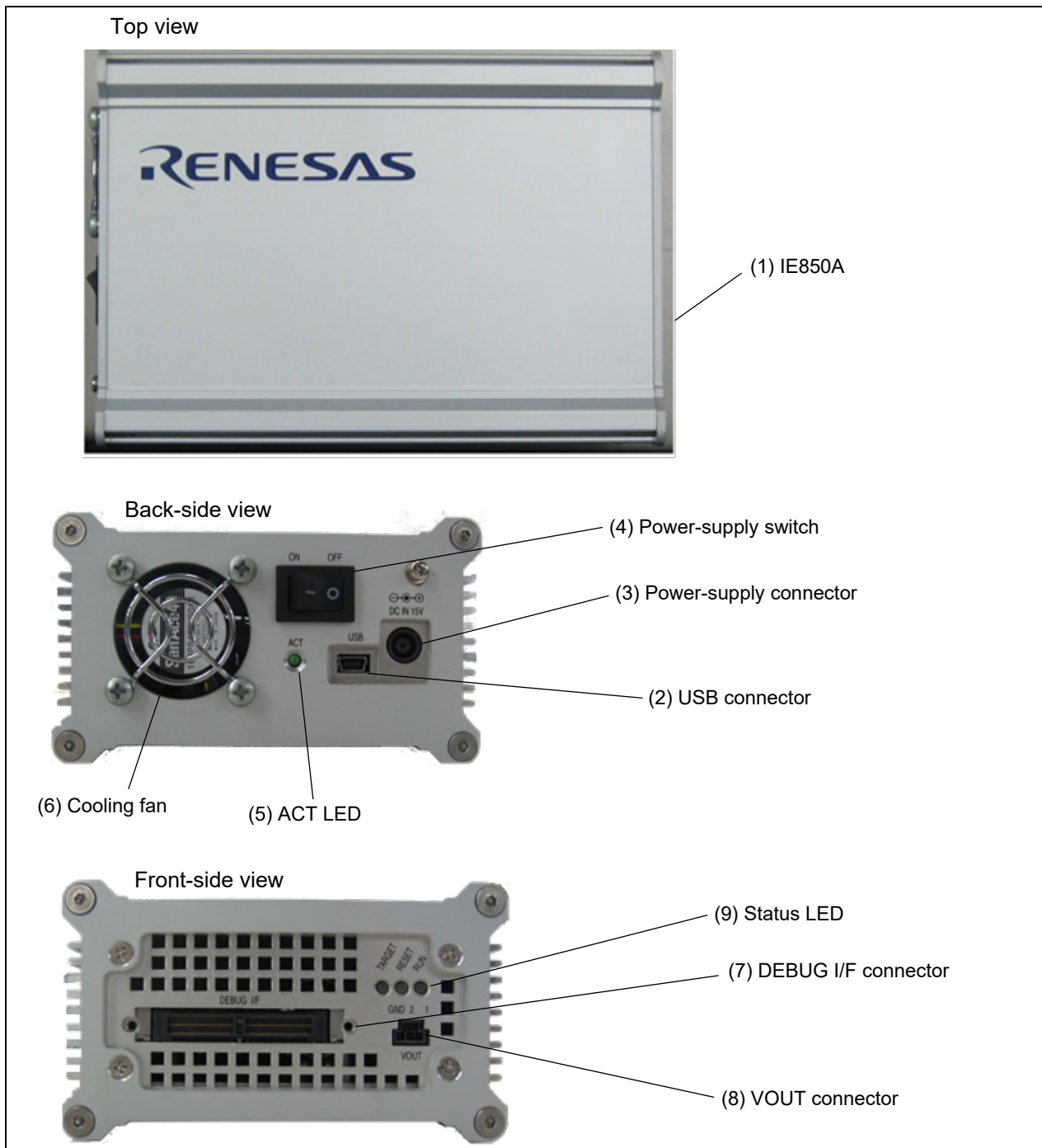

Figure 2-1 Names of the Parts of the IE850A (RTE0T0850AKCT00000J)

(1) IE850A main unit

The IE850A controls the debugging facilities of the target device and records in its trace memory trace data which are output from the device.

(2) USB connector

The USB connector is used to connect the USB cable.

(3) Power-supply connector

The power-supply connector is used to connect the AC adapter.

CAUTION	
AC adapter:	
	Refer to section 1.2 for using the AC adapter for the IE850A.

(4) Power-supply switch



Product	Part Number
ON (I)	Turns on the power supply of the IE850A.
OFF (O)	Turns off the power supply of the IE850A.

(5) ACT LED

Name of LED	State of LED	Specification
ACT	Blinking	The power supply of the IE850A is turned on but the debugger is not connected.
	Illuminated	The power supply of the IE850A is turned on and the debugger is connected.
	Not illuminated	The power supply of the IE850A is turned off or the cooling fan has malfunctioned (so the IE850A has stopped operating).

(6) Cooling fan

This fan cools the interior of the IE850A. The cooling fan operates while the IE850A is turned on. Take care that the vents are not obstructed.

 CAUTION	
Cooling fan:	
	If the cooling fan does not operate, the emulator's temperature will become extremely high to the extent of possibly causing injuries such as burns if you touch it. In such a situation, turn off the power immediately and request repairs to the emulator.

(7) DEBUG I/F connector

This connector is used to connect the trace cable for the IE850A.

(8) VOUT connector

This connector is used to connect the power-supply cable for the emulation adapter.

Whenever the power-supply switch of the IE850A is turned on, it starts supplying power through the VOUT connector. However, the IE850A has a facility for detecting an abnormal voltage or overcurrent at the destination of the supply of power through VOUT (i.e., the emulation adapter and target system). If the IE850A detects an abnormal state before it starts supplying power through VOUT, it does not start supplying power through VOUT. Furthermore, if the IE850A detects an abnormal state while it is supplying power through VOUT, it stops supplying power through VOUT.

Stoppage of the supply of power through VOUT is indicated by an error message from the debugger and the state of a status LED (TARGET LED) of the IE850A.

(9) Status LEDs

While the power-supply switch of the IE850A is turned off, all of the LEDs are off.

“Power supply through VOUT” refers to supplying power through the VOUT connector.

“Power supply of the target system” refers to the power supply which is connected to the TVCC pin of the emulator connector.

Name of LED	State of LED	Specification
TARGET	Illuminated (orange)	Power is being supplied through VOUT. The power supply of the target system is turned on.
	Illuminated (red)	Power is being supplied through VOUT. The power supply of the target system is turned off.
	Illuminated (green)	The power supply through VOUT has stopped. The power supply of the target system is turned on. The power supply through VOUT has been stopped since the IE850A detected an abnormal voltage or overcurrent at the destination of the power supply through VOUT or there was a fault in the IE850A.
	Not illuminated	The power supply through VOUT has stopped. The power supply of the target system is turned off. The power supply through VOUT has been stopped since the IE850A detected an abnormal voltage or overcurrent at the destination of the power supply through VOUT or there was a fault in the IE850A.
RESET	Illuminated	A reset is being applied (the reset signal on the target system is at the low level).
	Not illuminated	A reset is not being applied (the reset signal on the target system is at the high level).
RUN	Illuminated	A program is being run in the state that the debugger is connected.
	Not illuminated	The debugger is not connected or the debugger is connected and a break has occurred.

2.2 Trace Cable for the IE850A (Sold Separately)

The trace cable is used to connect the IE850A and the emulator connector (34-pin ASP-137973-01 from SAMTEC) on the target system.



Figure 2-2 Names of the Parts of the Trace Cable for the IE850A (RTE0T0850AKCAC0000J)

(1) IE850A-side connector

This connector is for connection to the DEBUG I/F connector for the IE850A. After you have connected it, tighten the screws on both sides of the connector.

(2) Target-side connector

This connector is for connection to the emulator connector (34-pin ASP-137973-01 from SAMTEC) mounted on the target system, which includes the emulation adapter. Press the spring latches on both sides of this connector when inserting or removing it.

(3) Spring latches

Press the spring latches on both sides when inserting or removing the cable and emulator connector.

CAUTION

Spring latches:



Be sure to press the spring latches when inserting or removing the cable and emulator connector. Failure to do so will damage the cable or the connector on the target system.

2.3 Power-Supply Cable for the Emulation Adapter

The IE850A can supply power to the emulation adapter by inserting the power-supply cable for the emulation adapter which comes with the IE850A into the VOUT connector of the IE850A and connecting it to the emulation adapter.

Whenever the power-supply switch of the IE850A is turned on, it starts supplying power through the VOUT connector. However, the IE850A has a facility for detecting an abnormal voltage or overcurrent at the destination of the supply of power through VOUT (i.e., the emulation adapter and target system). If the IE850A detects an abnormal state before it starts supplying power through VOUT, it does not start supplying power through VOUT. Furthermore, if the IE850A detects an abnormal state while it is supplying power through VOUT, it stops supplying power through VOUT.

Stoppage of the supply of power through VOUT is indicated by an error message from the debugger and the state of a status LED (TARGET LED) of the IE850A.

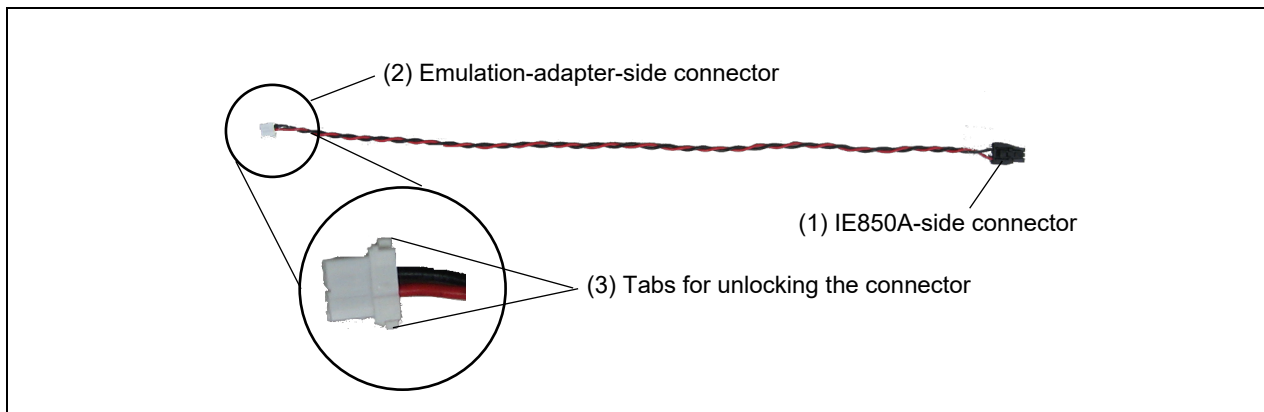
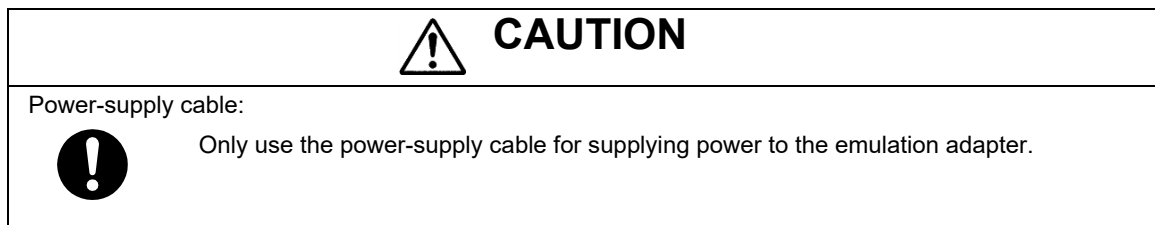

Figure 2-3 Names of the Parts of the Power-Supply Cable for the Emulation Adapter

(1) IE850A-side connector

This connector is for connection to the VOUT connector of the IE850A.

(2) Emulation-adapter-side connector

This connector (LEAR-02V-S from JST) is for connection to the power-supply connector on the emulation adapter.

(3) Tabs for unlocking the connector

When disconnecting the power-supply cable from the emulation adapter, press the tabs on both sides of the emulation-adapter-side connector to unlock the connector.

**CAUTION**

Unlocking the connector:



Do not press the tabs for unlocking the connector too hard as this may lead to them being stuck in this position. Take care on this point.

3. Setup Procedure

This chapter explains the procedures for setting up by connecting the IE850A to the target system.

3.1 Installing the Emulator Software

Download and install the latest version of the integrated development environment (IDE) from the following Web page before using the IE850A.

<https://www.renesas.com/us/en/products/software-tools/tools/ide/csplus.html#downloads>

If you are using CS+ from Renesas, the installation package includes a USB driver. If you are using an IDE from another manufacturer, contact your local distributor on this point.

3.2 Connecting the Trace Cable and Power-Supply Cable

Confirm that the IE850A main unit and the target system are turned off, and connect the trace cable for the IE850A as shown below. After that, tighten the screws on both sides of the connector to fix the connection between the IE850A and the target system.

When the target system is the emulation adapter, also connect the power-supply cable for the emulation adapter.



CAUTION

Connecting the connector:



Confirm the direction with the notch on the connector and connect the emulator while taking care that the direction of insertion is correct.

CAUTION

Applied voltage:



The IE850A supplies 5.5 V when it is supplying power to the emulation adapter.

3.3 Connecting the Target System

Confirm that the IE850A main unit and the target system are turned off, and connect the IE850A main unit to the target system via the trace cable for the IE850A as shown below.

Press the spring latches on both sides of the target-side connector of the cable when inserting or removing the trace cable for the IE850A.

When the target system is the emulation adapter, also connect the power-supply cable for the emulation adapter.

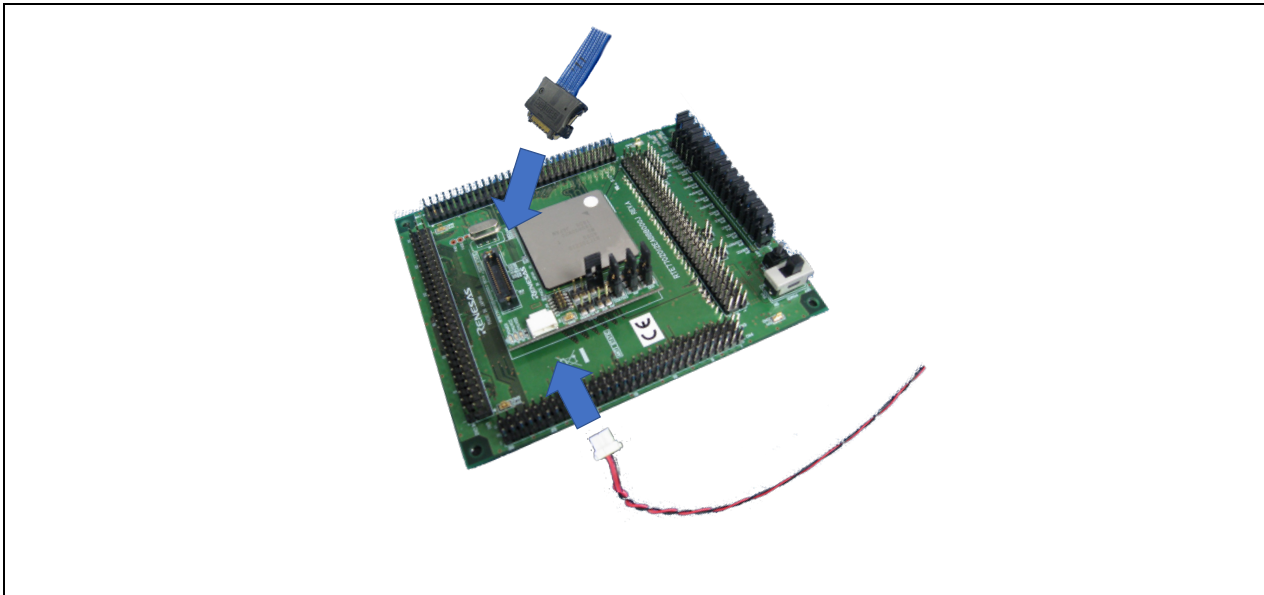
**CAUTION**

Connecting the connector:



Confirm the direction with the notch on the connector and connect the emulator while taking care that the direction of insertion is correct.

3.4 Connecting the USB Cable and the AC Adapter

Confirm that the IE850A main unit and the target system are turned off, and connect the AC adapter and the USB cable as shown below.

3.5 Turning on the IE850A Main Unit

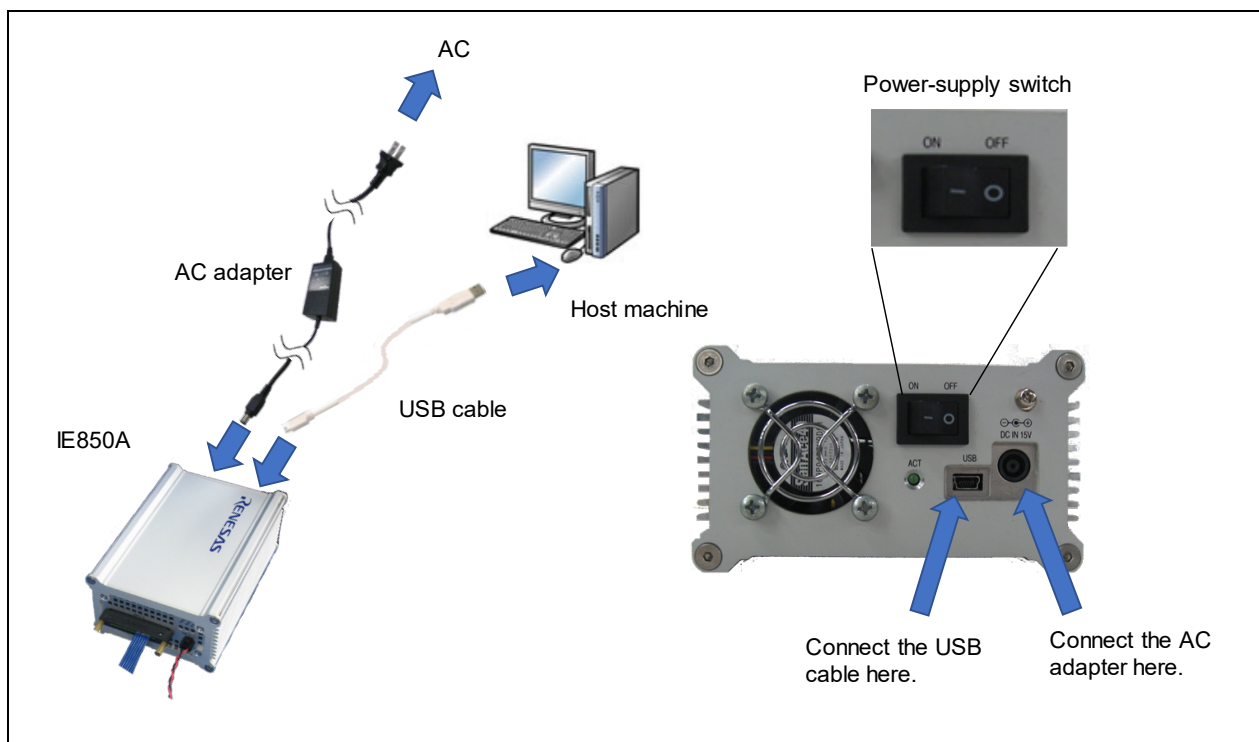

Confirm that the target system is turned off, and turn on the power-supply switch of the IE850A. The ACT LED of the IE850A, which was off, will blink or light up. The TARGET LED of the IE850A will be lit up in red.

If the ACT LED is off or TARGET LED is lit up in green or off, refer to chapter 6, Troubleshooting.

3.6 Turning on the Target System

After the target system is turned on, the TARGET LED of the IE850A will be lit up in orange. If the TARGET LED is lit up in green or off, refer to chapter 6, Troubleshooting.

3.7 Starting the Debugger

Start the debugger. For details on the subsequent debugging procedures, refer to the user's manual for the debugger you are using.

3.8 Shutdown Procedure

Shut down the development system according to the procedure below.

Exit the debugger. -> Turn the target system off. -> Turn the IE850A off.

4. Connecting the IE850A and Target System

To connect the IE850A to the target system, a connector for the emulator must be mounted on the target system. When designing the target system, read this chapter and the hardware manual for the MCUs to be used.

4.1 Emulator Connector for External Tracing

Table 4-1 shows the recommended connectors for connection of the IE850A. When other components are mounted around the connector, do not mount components with heights exceeding 6 mm on the user system as shown in Figure 4-1.

Table 4-1 Recommended Connector

Product	Manufacturer	Type Number
34-pin connector	SAMTEC	ASP-137973-01

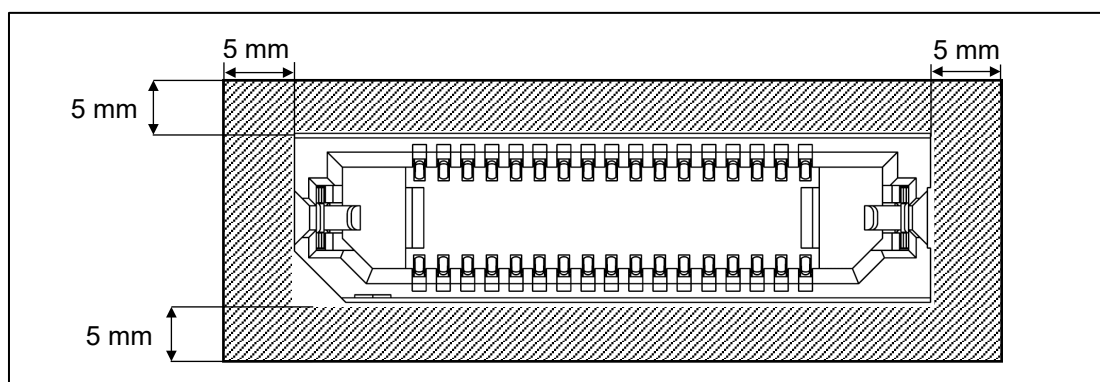

Figure 4-1 Area where Restriction Applies to Mounted Components

4.2 Pin Assignments of the Connector

Table 4-2 shows the pin assignments of the connector.

Table 4-2 Pin Assignments of the Connector for External Tracing

Signal Name	Pin No.	Pin No.	Signal Name
GND	Latch		GND
TODP0	1	2	TVCC
TODN0	3	4	TCK/LPDCLK
GND	5	6	TMS
TODP1	7	8	TDI/LPDI
TODN1	9	10	TDO/LPDO
GND	11	12	TRST/LPDRST
TODP2	13	14	FPMD0
TODN2	15	16	EVTI
GND	17	18	EVTO
TODP3	19	20	FPMD1
TODN3	21	22	RESET
GND	23	24	GND
MSYNZ	25	26	CICREFP
N.C.	27	28	CICREFN
GND	29	30	GND
N.C.	31	32	DRDY/LPDCLKO
N.C.	33	34	N.C.
GND	Latch		GND

- Notes: 1. Pins 27, 31, 33, and 34 may be required for use with an emulator from another manufacturer but are not used with the IE850A. Connecting these signals creates no problems if this is done in accord with the specifications of the emulator from another manufacturer.
2. Although connecting pins 16 (EVTI), 18 (EVTO), and 25 (MSYNZ) is not essential for debugging, we recommend connecting these pins in advance of using the connector. In some devices, the EVTI, EVTO, and MSYNZ pins are not present or the signals are only available as pin functions that are multiplexed with other functions. When these signals are present as multiplexed pin functions and the event output function is to be used, set the corresponding pins according to the user's manual for the device you are using.

CAUTION

Connection of an emulator from another manufacturer:



If you will be using an emulator from another manufacturer for debugging, be sure to read the manual for the given emulator beforehand.

4.3 Examples of Recommended Connections between the Emulator Connector and Target Device

This section describes examples of recommended connections between the emulator connector and the target device.

Table 4-3 Purpose of the IE850A and the Corresponding Example of Recommended Connections

Purpose	Section
Debugging (4-pin LPD, JTAG) and tracing (four lanes)	4.3.1
Debugging (4-pin LPD, JTAG) and tracing (two lanes)	4.3.2
Debugging (4-pin LPD, JTAG) and tracing (one lane)	4.3.3

Design a circuit that is appropriate in consideration of the following points.

 CAUTION	
	<p>Designing the circuit:</p> <p>Be sure to confirm the specifications of the target device before designing the circuit.</p>

- Design the circuit in consideration of noise.
- Make wiring runs between the connector and target device as short as possible.
- Do not connect the signal lines between the connector and MCU to other signal lines.
- Use GND to apply a guard ring for the wiring which runs between the connector and target device. Do not route high-speed signal lines parallel to each other or allow them to cross each other.
- Pin names may vary among target devices. Refer to the user's manual for the target device you are using for the actual pin names.
- Proceed with appropriate processing for pins of target devices which do not require connection to the emulator in accord with the descriptions in "Handling of Unused Pins" in the user's manual for the target device.
- Refer to section 4.3.4 for more information on the reset circuit.
- The signals for pins AURORES, EMUVCC, and EMUVDD of the target device are not assigned to the connector. However, if external tracing (Aurora tracing) is to be used, control these pins on the circuit of the target system according to the specifications of the device.
- The trace interface signals (CICREFP and CICREFN), (TODP0 and TODN0), (TODP1 and TODN1), (TODP2 and TODN2), and (TODP3 and TODN3) are differential pairs. Observe the specifications of the target device such as for wiring length, distance between the signals in the pairs, and differential impedance.
- For other points regarding the connection of trace interfaces, refer to the E2 Emulator, IE850A Additional Document for User's Manual.

4.3.1 Example of Recommended Connections for Debugging (4-Pin LPD, JTAG) and Tracing (Four Lanes)

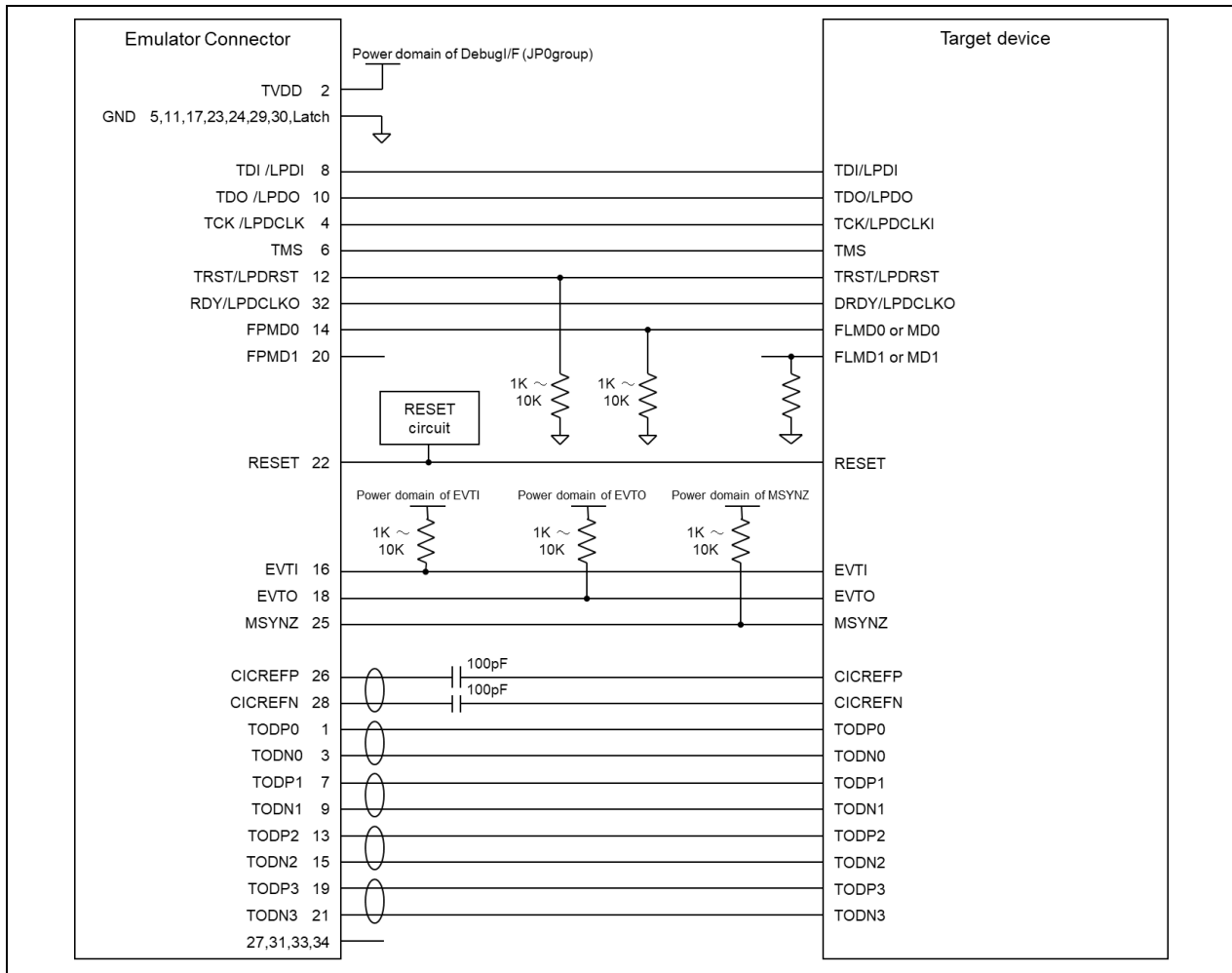

Figure 4-2 Example of Recommended Connections for Debugging (4-Pin LPD, JTAG) and Tracing (Four Lanes)

4.3.2 Example of Recommended Connections for Debugging (4-Pin LPD, JTAG) and Tracing (Two Lanes)

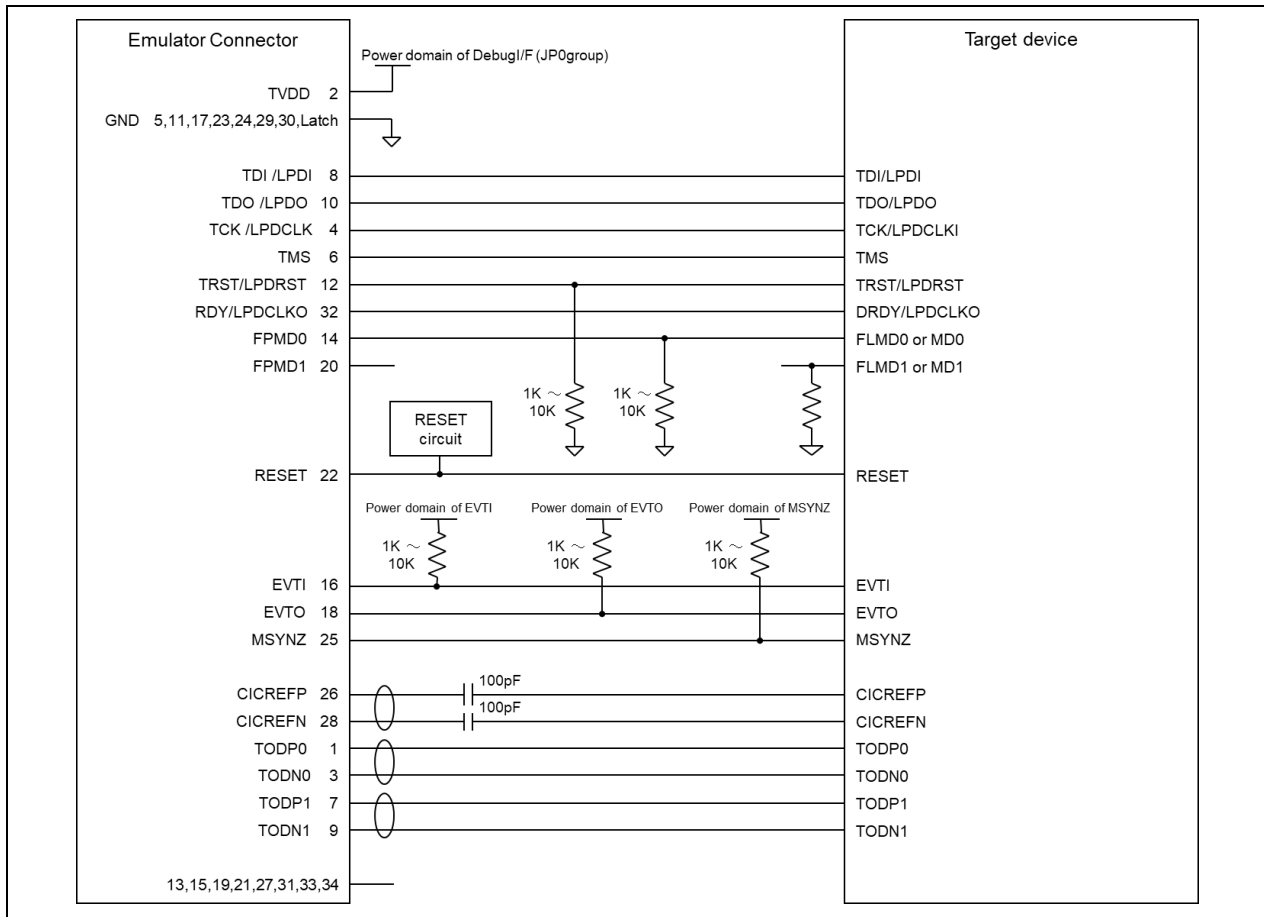

Figure 4-3 Example of Recommended Connections for Debugging (4-Pin LPD, JTAG) and Tracing (Two Lanes)

4.3.3 Example of Recommended Connections for Debugging (4-Pin LPD, JTAG) and Tracing (One Lane)

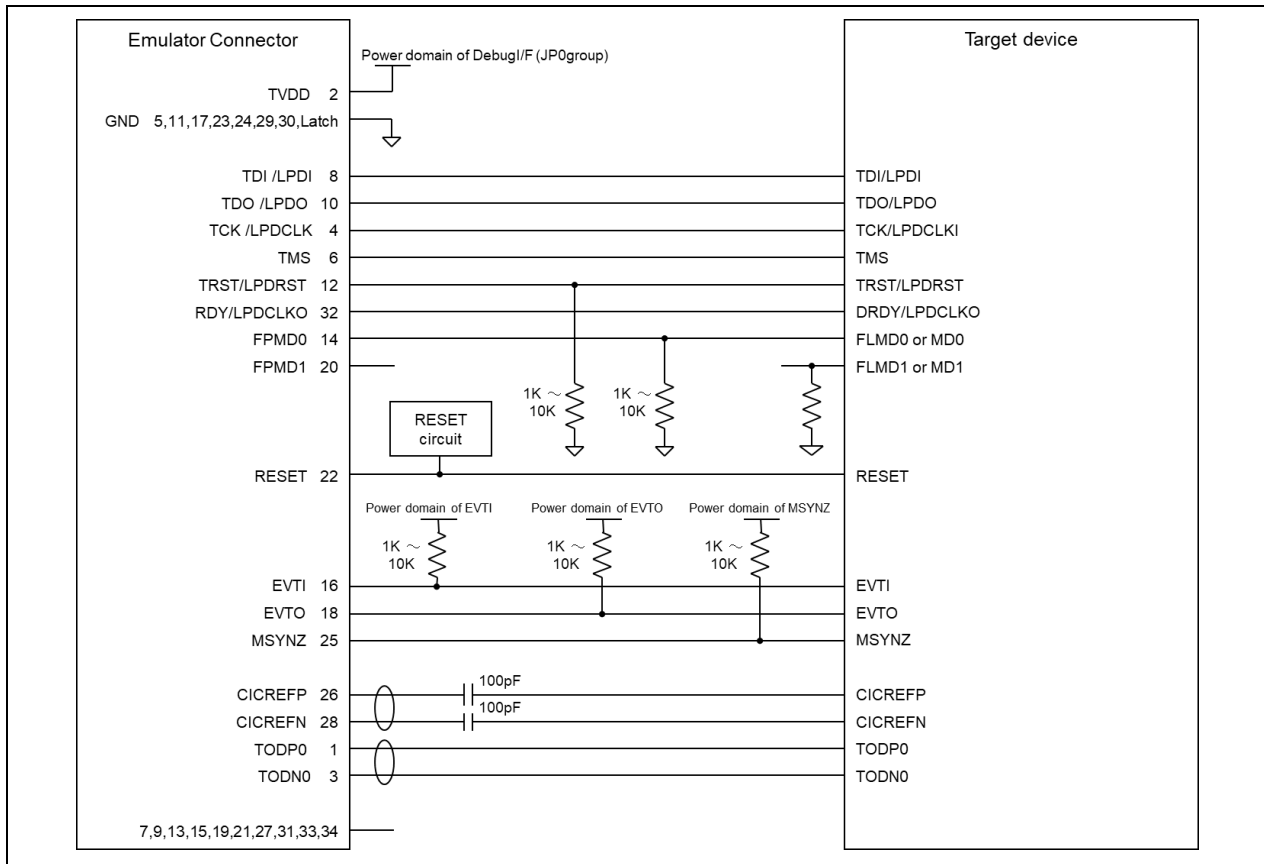

Figure 4-4 Example of Recommended Connections for Debugging (4-Pin LPD, JTAG) and Tracing (One Lane)

4.3.4 Connecting the RESET Pin

While you are using the IE850A, pin 22 (RESET pin) of the emulator connector must be connected to the reset pin of the target device. An example is shown in the figure below.

The IE850A fixes the RESET pin to the low level before the debugger is activated. After the debugger is activated, the emulator either keeps the pin at the low level or places it in the high-impedance state in accord with the operation of the debugger.

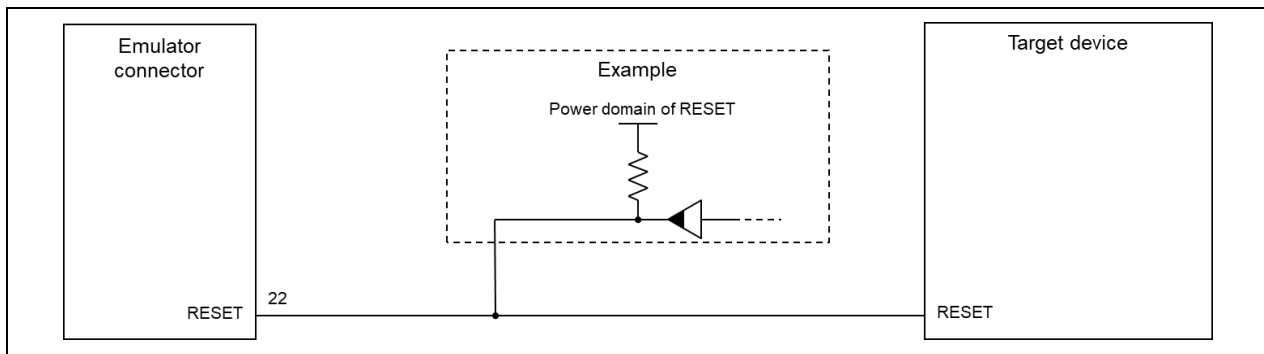

Figure 4-5 Example of Connecting a Reset Circuit

- Output of the reset circuit should be either n-channel open drain or be a signal generated solely by a resistor and capacitor (and possible other components).
- Use the power source for the power domain of the RESET pin of the target device as the destination voltage for pulling up.
- The RESET pin of the IE850A is pulled up (by a 100-kΩ resistor) within the emulator.
- The RESET pin of the target device may be pulled up or down within the device. On this point, refer to the user's manual for the target device.
- The maximum sink current accepted by the RESET pin of the IE850A is 2 mA. Select an appropriate pull-up resistance which does not surpass this value.
- Adjust the time constant of the reset circuit so that the time elapsing before the signal reaches 80% of the high level from the low level is within 900 μs.

5. Note

5.1 Capacity of Trace Memory

The available capacity of trace memory differs with the debugger. Refer to the user's manual for the debugger you are using.

6. Troubleshooting

The following table lists examples of problems that may arise when using the IE850A and the ways of solving them.

Details of the Problem	Error Message in CS+	Description and Resolution
The ACT LED light is off even though the power-supply switch of the IE850A is turned on.	E1200256	[Resolution] Confirm that the AC adapter for the IE850 or IE850A is connected to the power-supply connector.
	E1203261	[Resolution] Confirm the state of the cooling fan of the IE850A. If the cooling fan has stopped, request repairs.
While the IE850A is turned on, the casing becomes hot.	E1203261	[Resolution] Confirm the state of the cooling fan. If the cooling fan has stopped, turn the IE850A off and request repairs. If the casing becomes hot despite the cooling fan operating, you must also request repairs.

<p>The TARGET LED of the IE850A is off or is lit up in green (the power supply through VOUT has stopped).</p>	<p>E1203277</p>	<p>[Description] The supply of power through VOUT (power supply through VOUT) cannot be started. The IE850A does not start supplying power through VOUT if it detects a voltage at the destination of the supply of power through VOUT on the target system even if the supply of power through VOUT has not started. Supplying power may also not be started due to a fault in the IE850A.</p> <p>[Resolution 1] Turn off the power to the IE850A, emulation adapter, and target system, disconnect the power-supply cable and trace cable (so that the target system is not connected), and turn on the power-supply switch of the IE850A.</p> <ul style="list-style-type: none"> • When the TARGET LED is lit up in red: The power supply of the emulation adapter or target system might have been abnormal. Remove the IE850A and confirm the state of the emulation adapter or target system. Examples: <ul style="list-style-type: none"> — Another power supply is connected as the power supply of the destination for the supply of power through VOUT. — There is a leak in the power supply of the destination for the supply of power through VOUT. — The power supply of the destination for the supply of power through VOUT has a short circuit. • When the TARGET LED is off: The IE850A might have a fault. Request repairs. <p>[Resolution 2] Refer to chapter 3, Setup Procedure, and the user's manual for the emulation adapter to check the procedure for turning the power on. Turn the IE850A on before turning the emulation adapter and target system on.</p>
---	-----------------	---

7. Maintenance and Warranty

This chapter covers basic maintenance, warranty information, provisions for repair and the procedures for requesting a repair.

7.1 Maintenance

- (1) If dust or dirt collects on this product, wipe it off with a dry soft cloth. Do not use thinner or other solvents because these chemicals can cause the surface coating to separate.
- (2) When you do not use this product for a long period, disconnect it from the power supply, host machine, and target system.

7.2 Warranty

- (1) This product comes with a one-year warranty after purchase.
Should the product break down or be damaged while you're using it under normal conditions in accord with its user's manual, it will be repaired or replaced free of cost.
- (2) However, if the following types of failure or damage to the product occur during the term of the warranty, repairing or replacing the product will incur a cost.
 - a) Failure or damage attributable to the misuse or abuse of the product or its use under other abnormal conditions.
 - b) Failure or damage attributable to improper handling of the product after purchase, such as dropping the product while it is being transported or otherwise moved.
 - c) Failure or damage to the product caused by other pieces of equipment connected to it.
 - d) Failure or damage attributable to fire, earthquakes, thunderbolts, floods, or other natural disasters, or to abnormal voltages, etc.
 - e) Failure or damage attributable to modifications, repairs, adjustments, or other acts in relation to the product by parties other than Renesas Electronics Corp.
- (3) Consumables (e.g., sockets, adaptors and cables) are beyond the scope of repair and replacement.

In the above cases, contact your local distributor. If you are renting the product, consult the company you are renting it from or the owner.

7.3 Repair Provisions

- (1) Repairs not covered by warranty
Problems arising in products for which more than one year has elapsed since purchase are not covered by warranty.
- (2) Replacement not covered by warranty
If your product's fault falls into any of the following categories, the fault will be corrected by replacing the entire product instead of repairing it, or you will be advised to purchase a new product, depending on the severity of the fault.
 - Faulty or broken mechanical portions
 - Flaws, separation, or rust in coated or plated portions
 - Flaws or cracks in plastic portions
 - Faults or breakage caused by improper use or unauthorized repair or modification
 - Heavily damaged electric circuits due to overvoltage, overcurrent or shorting of power supply
 - Cracks in the printed circuit board or burnt-down patterns

- A wide range of faults that make replacement less expensive than repair
 - Faults that are not locatable or identifiable
- (3) Expiration of the repair period
- We accept requests for repairs up to three years after production of a given model has ceased.
 - Repairing a given model may become impossible even during the above period if the parts required for the repairs are no longer available.
- (4) Carriage fees for sending your product to be repaired
- Carriage fees for sending your product to us for repair are at your own expense.

7.4 How to Request Repairs

If your product is found faulty, fill in a Repair Request Sheet downloadable from the following URL and email the sheet and send the product to your local distributor.

<https://www.renesas.com/repair>

CAUTION

Note on Transporting the Product:



When sending your product for repair, use the packing box and cushioning material supplied with the MCU unit when it was delivered to you and specify caution in handling (handling as precision equipment). If packing of your product is not complete, it may be damaged during transportation. When you pack your product in a bag, make sure to use the conductive plastic bag supplied with the MCU unit (usually a blue bag). If you use a different bag, it may lead to further trouble with your product due to static electricity.

Revision History	IE850A Emulator User's Manual
------------------	-------------------------------

Rev.	Date	Description	
		Page	Summary
1.00	Dec.01.18	—	First Edition issued
1.10	Apr.22.19	Overall	Statements regarding signal words were reviewed.
		17, 18	Statements regarding an LED and the cooling fan were added.
		20	A statement regarding the power-supply cable for the emulation adapter was added.
		24	A statement regarding the LEDs when the IE850A is started was added.
		25	The external dimensions of the area to which a restriction applies to mounted components in Figure 4-1 were modified in consideration of the size of the 34-pin to 14-pin conversion adapter.
		32-34	Chapter 6, Troubleshooting, was added.
1.20	Jul.29.22	27	For the purpose of the IE850A, debugging (4-pin LPD, JTAG) and tracing (two lanes) was added in Table 4-3.
		28, 30	JTAG signals were added.
		29	Section 4.3.2, Example of Recommended Connections for Debugging (4-Pin LPD, JTAG) and Tracing (Two Lanes), was added.

IE850A Emulator User's Manual

Publication Date: Rev.1.00 Dec.01.18
Rev.1.10 Apr.22.19
Rev.1.20 Jul.29.22

Published by: Renesas Electronics Corporation

IE850A Emulator
RTE0T0850AKCT00000J
User's Manual



Renesas Electronics Corporation

R20UT4461EJ0120