

GreenPAK Lite Development Board

GreenPAK Lite Development Board provides full set of programming, emulation, and testing functions for the GreenPAK devices. Works in pair with the Go Configure Software Hub. Board functionality is provided by RX66T series MCU from Renesas.

Specifications

The GreenPAK Lite Development Board R1.1 is optimized for the following operating conditions:

- USB 2.0 specifications to power the board (5.0 V, 500 mA)
- Operating System: Windows 7/8.1/10/11, macOS (v10.15 or higher), Ubuntu 18.04/20.04/22.04, Debian 11/Testing

Kit Contents

- GreenPAK Lite Development Board
- USB cable

Features

- USB 2.0 board power and communication
- DIP and Socket Adapters support
- Dual VDD support
- Build in current meter for both VDD and VDD2 power sources
- USB-I2C Bridge functionality
- 18 individually configurable Test Points (TP):
 - Onboard LED state indication
 - Pull-up, Pull-down, GND, VDD, Hi-Z, VDD2
 - Programmable software button
- Configurable dual pin header for user schematic integration and signal monitoring (Expansion connector)
- 4 floating hooks for probe connection

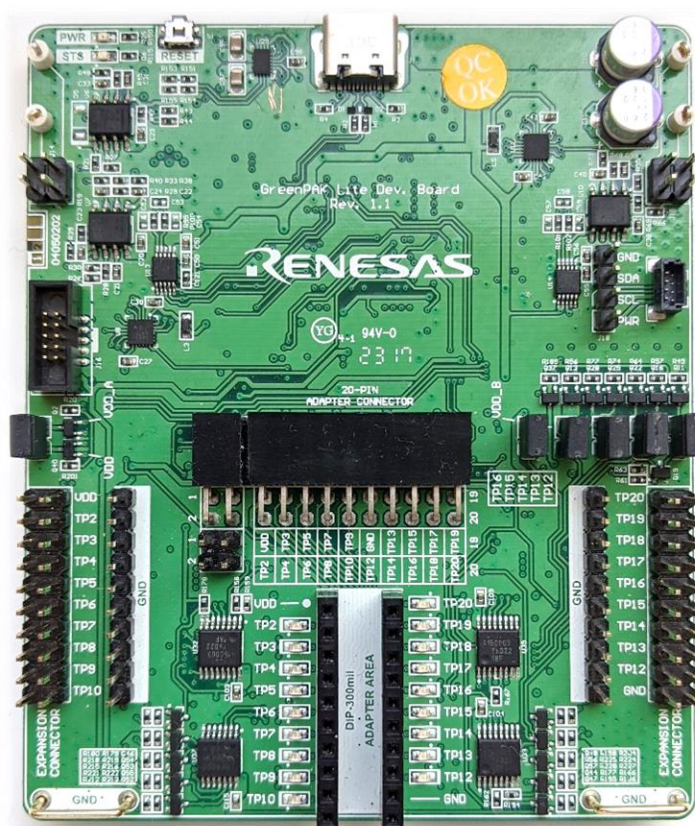

Figure 1. GreenPAK Lite Development Board

Contents

Specifications.....	1
Kit Contents.....	1
Features	1
1. Functional Description.....	4
2. Working with GreenPAK	7
2.1 DIP and Socket Connectors	7
2.1.1. DIP and Socket Connectors Specifications	8
2.2 Expansion Connector	8
2.2.1. Expansion Connector Specifications	10
2.3 GPSD Connector	11
2.3.1. GPSD Connector Specifications	13
2.4 Advanced In-System Programming Connector	14
2.4.1. Advanced In-System Programming Connector Specifications	14
3. Additional Features	15
3.1 LED Indication	15
3.2 Probe Connection	15
3.3 Board Status Indication	15
3.4 Reset Button and Firmware Update	16
4. Ordering Information.....	18
5. Revision History	19

Figures

Figure 1. GreenPAK Lite Development Board.....	1
Figure 2. GreenPAK Lite Development Board Blocks	4
Figure 3. TP3 as Real Time Control Interface	5
Figure 4. TP14 as Power Source	5
Figure 5. DIP Adapter Pinout.....	7
Figure 6. Socket Adapter Pinout.....	7
Figure 7. DIP Adapter Connection.....	7
Figure 8. Socket Adapter Connection.....	7
Figure 9. Debugging Setup for DIP and Socket Adapters	7
Figure 10. Expansion Connector Pinout.....	9
Figure 11. External DIP Adapter Connection to Expansion	9
Figure 12. Debugging Setup.....	9
Figure 13. External Oscilloscope Connection.....	10
Figure 14. Debugging Setup.....	10
Figure 15. Training Board #2 Connection.....	10
Figure 16. Debugging Setup.....	10
Figure 17. GPSD Connector Pinout	12
Figure 18. External DIP Adapter Connection to GPSD	12
Figure 19. Debugging Setup.....	12
Figure 20. Training Board #2 Connection.....	13
Figure 21. Debugging Setup.....	13
Figure 22. Advanced ISP Connector Pinout.....	14
Figure 23. TP LED Indication Configuration	15
Figure 24. Current Meter Connection	15
Figure 25. Oscilloscope Connection.....	15
Figure 26. Board Status Indication and RESET Button.....	15
Figure 27. Board Revision Location	17

Tables

Table 1. Test Point Functions	6
Table 2. VDD and VDD2 Specifications	8
Table 3. TP2-TP10, TP12-TP20 Specifications.....	8
Table 4. E_VDD Specifications	10
Table 5. E_TP2-E_TP10, E_TP12-E_TP20 Specifications.....	11
Table 6. PWR Specifications	13
Table 7. SCL, SDA Specifications	13
Table 8. KEY Specifications	14
Table 9. LED Signals Description	16

1. Functional Description

The GreenPAK Lite Development Board R1.1 provides full debugging capabilities for the GreenPAK family ICs. It has the necessary modules and peripherals to power the IC, measure voltages, generate digital signals. Expansion connector was designed to connect the GreenPAK Lite Development Board to external circuits, apply external power, signal sources, and loads. It can be used to apply the GreenPAK chip to the custom design with minimal additional tools.

The main components and their basic functions are shown in [Figure 2](#).

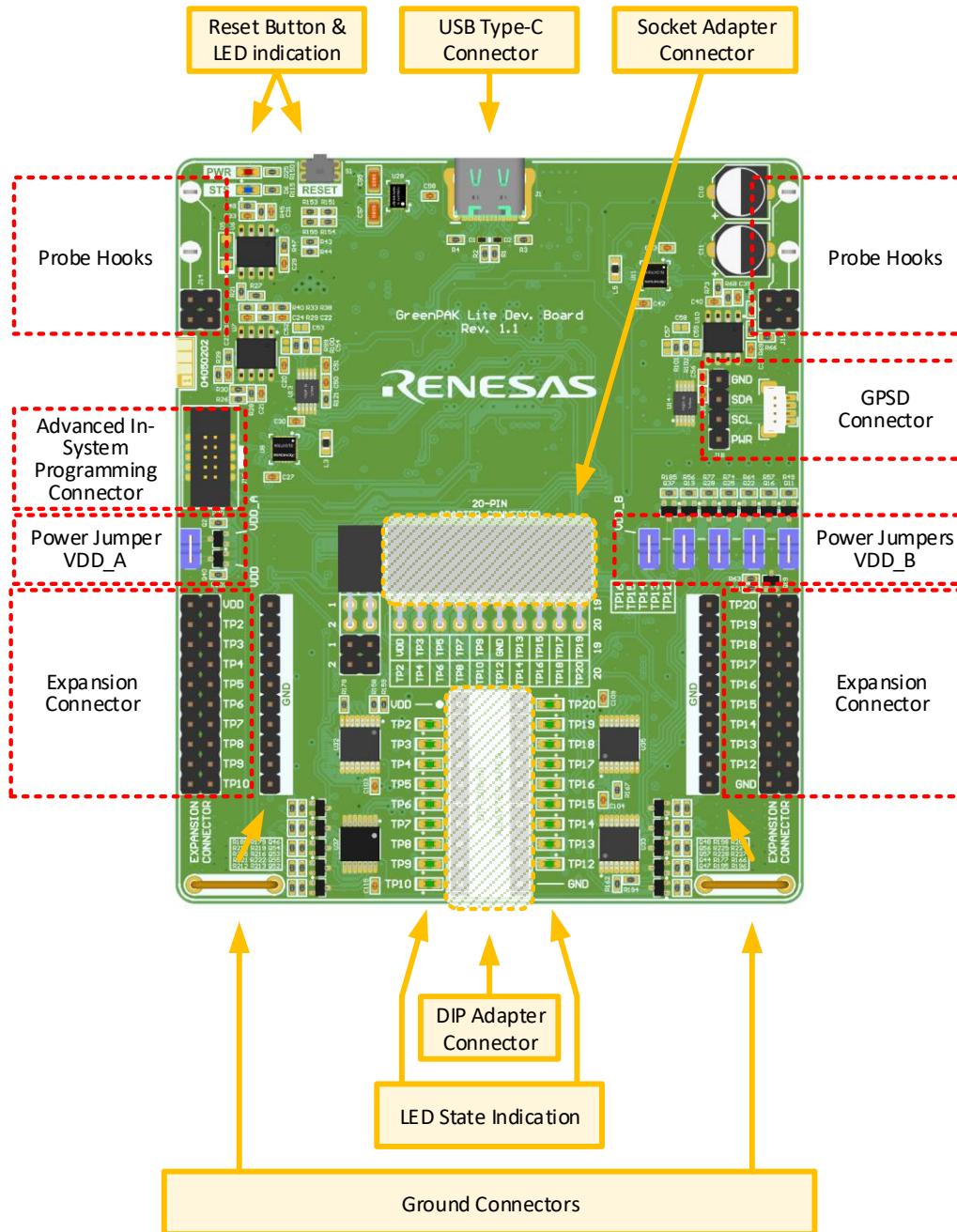

Figure 2. GreenPAK Lite Development Board Blocks

A set of Test Points provides all interactions between Lite Development Board and GreenPAK integrated circuits. Test Points are configured by the software depending on the actual IC's manufacturer part number. There are three main options for Test Points – programming interface, real time control interface, and configurable power source. Programming interface works only during programming and emulation. When programming or emulation entry is done – programming interface Test Points move their functionality to real time control or power source depending on GreenPAK part number. [Figure 3](#) and [Figure 4](#) show power and real time control configurations in Go Configure Software. [Table 1](#) describes functions set for each certain Test Point

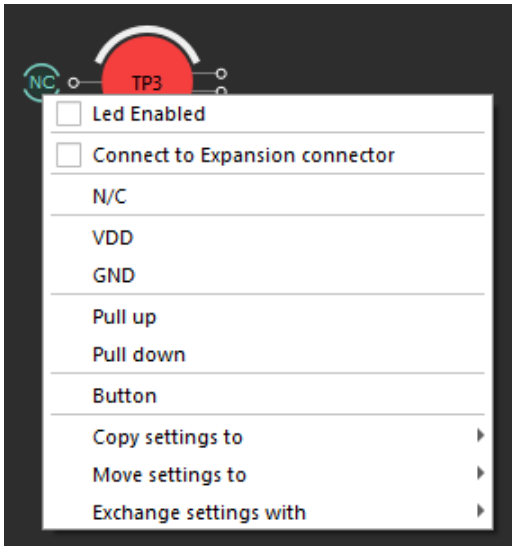

Figure 3. TP3 as Real Time Control Interface

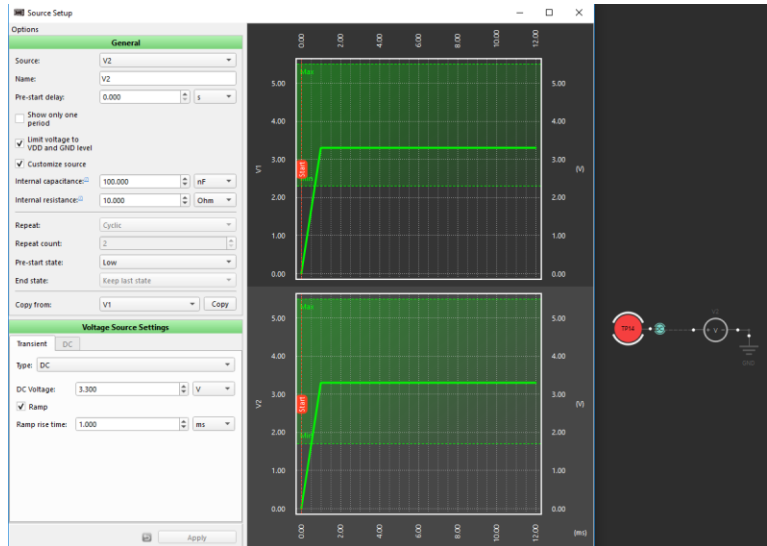

Figure 4. TP14 as Power Source

Table 1. Test Point Functions

Connector	Pin Label	Set to VDD1	Set to GND	Pull-up (V1)	Pull-down	SET Button	Buffered LED	VDD1 (V1)	VDD2 (V2)	Not Connected	EC Connection
20-pin ADAPTER CONNECTOR	TP1 (VDD)	+	-	-	-	-	-	+	-	+	+
	TP2	+	+	+	+	+	+	-	-	+	+
	TP3	+	+	+	+	+	+	-	-	+	+
	TP4	+	+	+	+	+	+	-	-	+	+
	TP5	+	+	+	+	+	+	-	-	+	+
	TP6	+	+	+	+	+	+	-	-	+	+
	TP7	+	+	+	+	+	+	-	-	+	+
	TP8	+	+	+	+	+	+	-	-	+	+
	TP9	+	+	+	+	+	+	-	-	+	+
	TP10	+	+	+	+	+	+	-	-	+	+
	GND	-	+	-	-	-	-	-	-	-	-
	TP12	+	+	+	+	+	+	-	+	+	+
	TP13	+	+	+	+	+	+	-	+	+	+
	TP14	+	+	+	+	+	+	-	+	+	+
	TP15	+	+	+	+	+	+	-	+	+	+
	TP16	+	+	+	+	+	+	-	+	+	+
	TP17	+	+	+	+	+	+	-	-	+	+
	TP18	+	+	+	+	+	+	-	-	+	+
	TP19	+	+	+	+	+	+	-	-	+	+
	TP20	+	+	+	+	+	+	-	-	+	+

Test Point with EC connection option is described as E_TPxx in section [2.2 Expansion Connector](#).

2. Working with GreenPAK

There are five connectors that can establish a connection between GreenPAK and Lite Development Board.

2.1 DIP and Socket Connectors

GreenPAK Lite Development Board works with GreenPAK family products using Socket and DIP Adapters. TP12- TP16 can be configured as VDD2 power sources for dual power devices. Difference between these two connectors is only in form factor. Pinout remains identical.

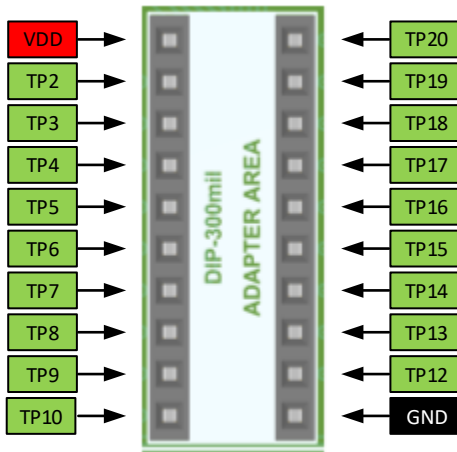

Figure 5. DIP Adapter Pinout

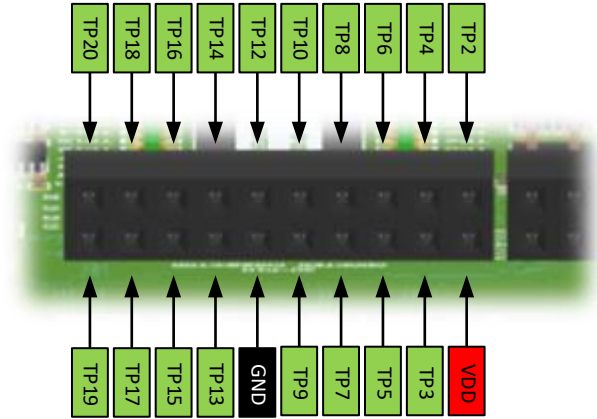

Figure 6. Socket Adapter Pinout

Socket and DIP Adapters connection is shown in Figure 7 and Figure 8.

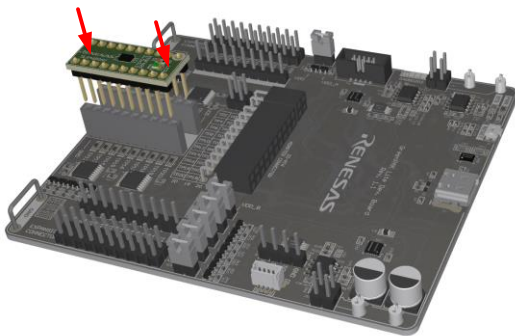

Figure 7. DIP Adapter Connection

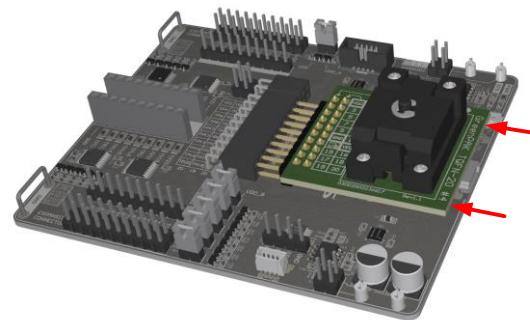

Figure 8. Socket Adapter Connection

Note: Do not use Socket Adapter and DIP Adapter at the same time.

Figure 9 shows debugging control setup for working with DIP and Socket Adapters, device type should be Onboard. Programming option for one time programmable (OTP) devices is available only by using DIP and Socket connectors.

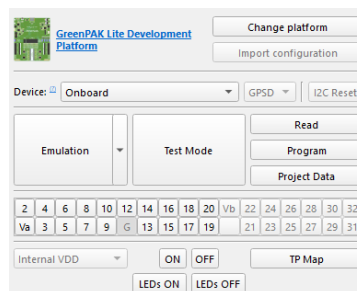

Figure 9. Debugging Setup for DIP and Socket Adapters

2.1.1. DIP and Socket Connectors Specifications

Table 2 shows onboard power specifications.

Table 2. VDD and VDD2 Specifications

Parameter	Description	Min	Typ	Max	Unit
V	Output Voltage Range	1.65	--	5.5	V
ΔV	Output Voltage Adjustment Step	--	50	--	mV
I_{max}	Maximum Output Current	--	150	--	mA
I_l	Switch "OFF" Leakage Current	--	--	500	nA

Table 3 describes TPs specifications. All TPs can be configured as inputs or outputs. Depending on socket or DIP adapter type TPs can be shared with digital programming interfaces, such as I2C or SPI. When working with OTP devices high voltage on TP2 can appear during emulating and programming.

Table 3. TP2-TP10, TP12-TP20 Specifications

Parameter	Description	Condition	Min	Typ	Max	Unit
As Output						
V_O	Output Voltage Level Range	Based on VDD setup	1.65	--	5.5	V
V_{OH}	Output High Voltage	VDD = 5.5 V	5.329	--	--	V
V_{OL}	Output Low Voltage	VDD = 5.5 V	--	--	0.08	V
I_{OH}	Output Current High	VDD = 5.5 V	--	--	50	mA
I_{OL}	Output Current Low	VDD = 5.5 V	--	--	50	mA
As Input						
V_I	Input Voltage Level Range	Based on VDD setup	-0.2	--	VDD+0.2	V
V_{IH}	Input High Voltage		0.7xVDD	--	--	V
V_{IL}	Input Low Voltage		--	--	0.3xVDD	V
I_l	Input Leakage Current		--	--	2	μA
R_{PULL}	Configurable Pull-up and Pull-down Resistance		--	1	--	M Ω
			--	100	--	k Ω
			--	10	--	k Ω
C_{IN}	Input Capacitance		--	20	--	pF

2.2 Expansion Connector

Expansion connector is used for external circuit connection and signal monitoring. This connector duplicates DIP and Socket connectors functionality. E_VDD is a configurable power source. It can also be set as voltage reference input to synchronize voltage level with external circuit. E_VDD source/reference setup, output voltage, connection between TP and E_TP are controlled in Go Configure Software Hub.

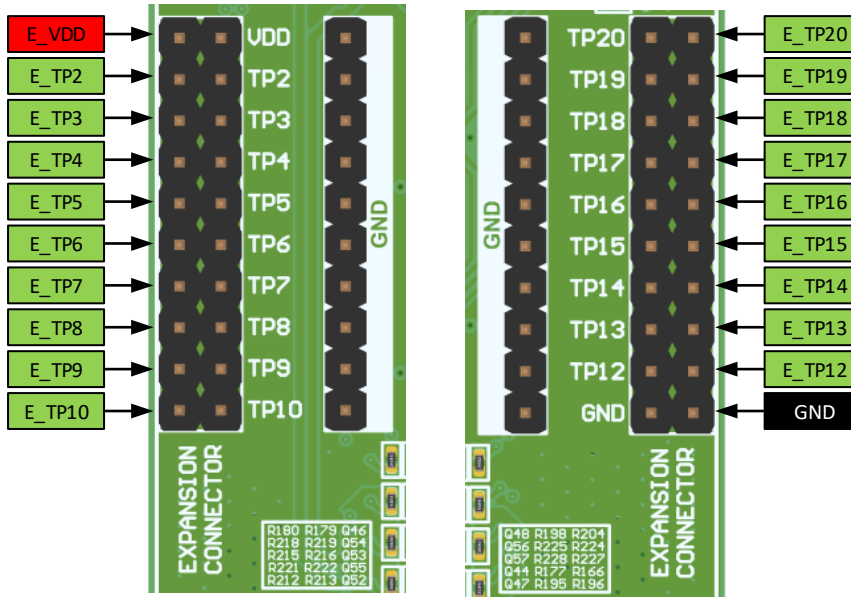

Figure 10. Expansion Connector Pinout

Figure 11 shows emulation of SLG46826V DIP adapter on the breadboard side. Default and actual device address code is 0001. Power for DIP adapter is provided by the Lite Development Board. Figure 12 shows debugging control setup for this use case. For external power supply connection remains the same. E_VDD should be connected to power supply to synchronize voltage level on TPs. VDD setup should be changed to External VDD.

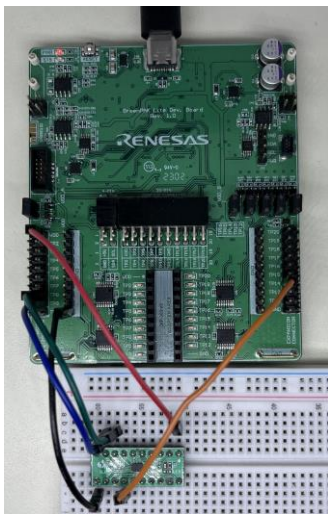

Figure 11. External DIP Adapter Connection to Expansion

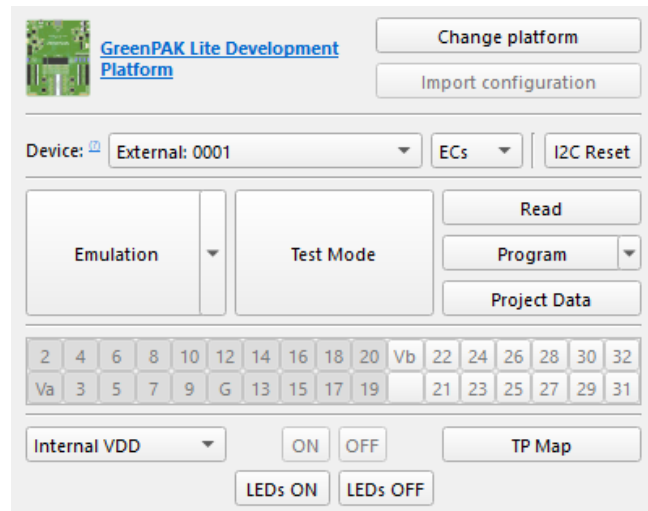

Figure 12. Debugging Setup

Expansion connector is also used for laboratory equipment connection. Figure 13 shows TP2 and VDD monitoring with the oscilloscope. Hooks should be manually connected to TPs with jumper wires. Figure 14 shows debugging control setup for this use case.

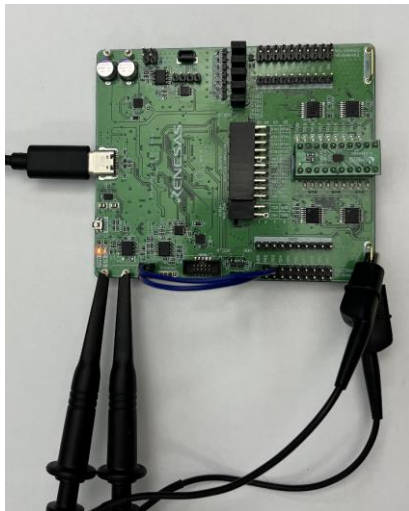

Figure 13. External Oscilloscope Connection

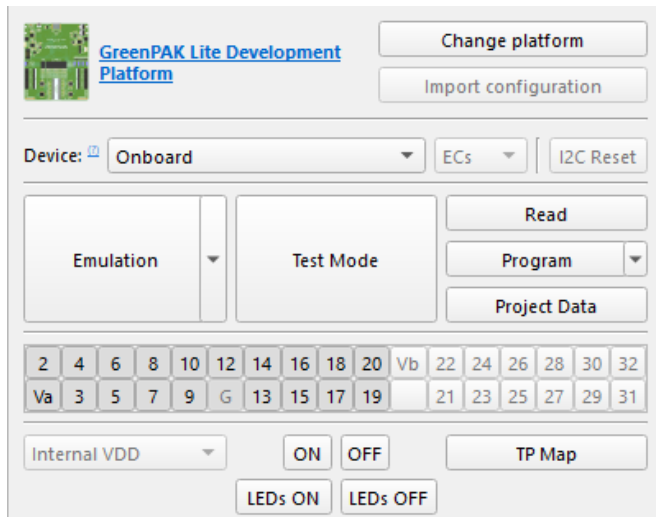

Figure 14. Debugging Setup

GreenPAK Training Board #2 works with the Lite Development Board through expansion connector. Figure 15 shows correct connection example. Jumper J4 should be removed from Training Board. Figure 16 shows debugging control setup for this use case.



Figure 15. Training Board #2 Connection

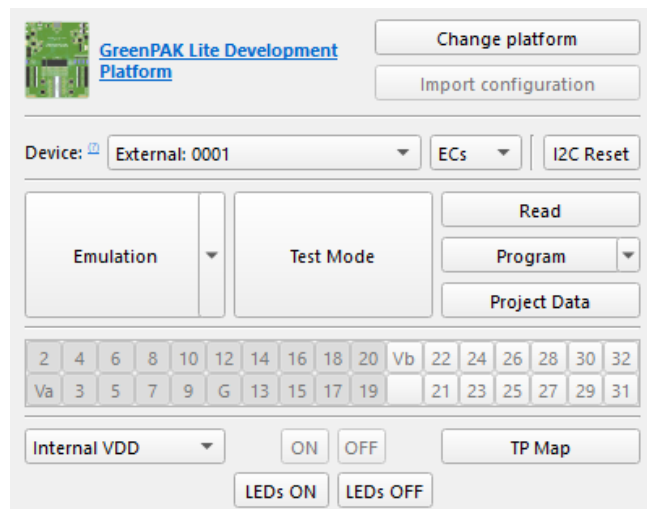

Figure 16. Debugging Setup

2.2.1. Expansion Connector Specifications

Table 4 shows External power specifications.

Table 4. E_VDD Specifications

Parameter	Description	Min	Typ	Max	Unit
V_O	Output Voltage Range	1.65	--	5.5	V
V_I	Input Voltage Range	1.65	--	5.5	V
ΔV	Output Voltage Adjustment Step	--	50	--	mV
I_{max}	Maximum Output Current	--	150	--	mA

Parameter	Description	Min	Typ	Max	Unit
R _I	Input Impedance	--	100	--	kΩ
C _I	Input Capacitance	--	10	--	μF

Table 5 describes E_TPs specifications. All E_TPs can be configured as inputs or outputs. Connection between E_TP and TP, E_VDD and VDD automatically disables during programming and emulation.

Table 5. E_TP2-E_TP10, E_TP12-E_TP20 Specifications

Parameter	Description	Condition	Min	Typ	Max	Unit
As Output						
V _O	Output Voltage Level Range	Based on E_VDD setup	1.65	--	5.5	V
V _{OH}	Output High Voltage	E_VDD = 5.5 V	5.329	--	--	V
V _{OL}	Output Low Voltage	E_VDD = 5.5 V	--	--	0.08	V
I _{OH}	Output Current High	E_VDD = 5.5 V	--	--	20	mA
I _{OL}	Output Current Low	E_VDD = 5.5 V	--	--	20	mA
As Input						
V _I	Input Voltage Level Range	Based on E_VDD setup	-0.2	--	E_VDD+0.2	V
V _{IH}	Input High Voltage		0.7xE_VDD	--	--	V
V _{IL}	Input Low Voltage		--	--	0.3xE_VDD	V
I _I	Input Leakage Current		--	--	2.5	μA
R _{PULL}	Configurable Pull-up and Pull-down Resistance		--	1	--	MΩ
			--	100	--	kΩ
			--	10	--	kΩ
C _{IN}	Input Capacitance		--	30	--	pF

2.3 GPSD Connector

GPSD connector provides a standard In-system debugging option for GreenPak Family integrated circuits. Basically, it is I2C interface with regulated voltage level option. PWR is a configurable power source. It can also be set as voltage reference input to synchronize voltage level with external circuit. PWR source/reference setup and output voltage are controlled in Go Configure Software Hub.

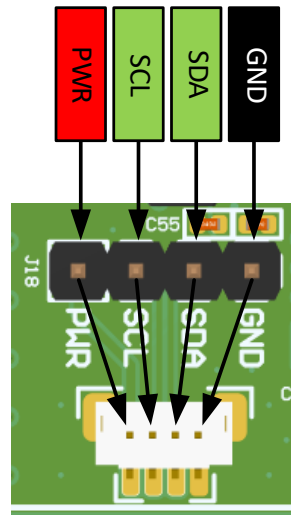

Figure 17. GPSD Connector Pinout

Figure 18 demonstrates emulation of SLG46826V DIP adapter on the breadboard side. Default and actual device address code is 0001. Power for DIP adapter is provided by Lite Development Board. Figure 19 shows debugging control setup for this use case. For external power supply connection remains the same. PWR should be connected to power supply to synchronize voltage level on TPs. VDD setup should be changed to External VDD.

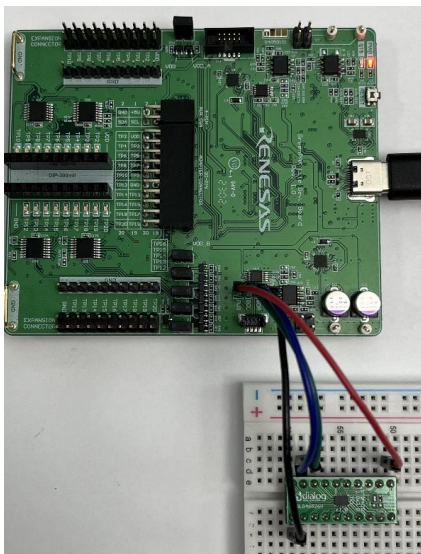

Figure 18. External DIP Adapter Connection to GPSD

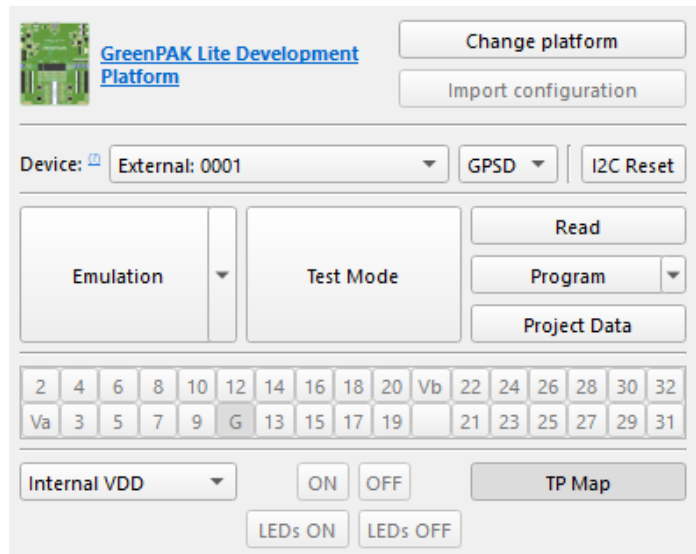

Figure 19. Debugging Setup

GreenPAK Training Board #2 works with Lite Development Board through expansion connector. Figure 20 shows correct connection example. Jumper J4 should be installed on Training Board. Figure 21 shows debugging control setup for this use case.



Figure 20. Training Board #2 Connection

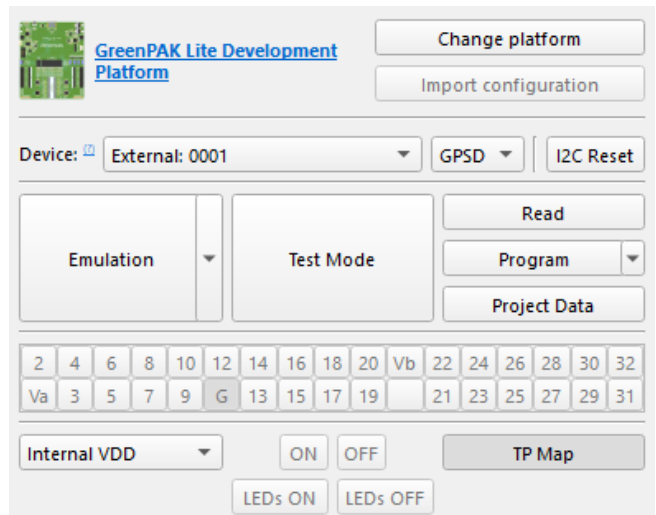

Figure 21. Debugging Setup

2.3.1. GPSD Connector Specifications

Table 6 shows GPSD power specifications.

Table 6. PWR Specifications

Parameter	Description	Min	Typ	Max	Unit
V	Output Voltage Range	0.9	--	5.5	V
ΔV	Output Voltage Adjustment Step	--	50	--	mV
V_I	Input Voltage Range	0.9	--	5.5	V
I_{max}	Maximum Output Current	--	150	--	mA
R_I	Input Impedance	--	100	--	k Ω
C_I	Input Capacitance	--	20	--	pF

Table 7 describes GPSD I2C pins specifications while using interface in Go Configure Software. When interface is not active, pull-up resistors are disabled.

Table 7. SCL, SDA Specifications

Parameter	Description	Condition	Min	Typ	Max	Unit
SCL						
V_O	Output Voltage Level Range	Based on PWR setup	0.9	--	5.5	V
V_{OH}	Output High Voltage	PWR = 5.5 V	--	--	PWR	V
V_{OL}	Output Low Voltage	PWR = 5.5 V	--	--	0.08	V
R_{PULL}	Pull-up Resistance		--	1.8	--	k Ω
I_{oL}	Output Current LOW	PWR = 5.5 V	--	--	15	mA
SDA						
V_O	Output Voltage Level Range	Based on PWR setup	0.9	--	5.5	V

Parameter	Description	Condition	Min	Typ	Max	Unit
V _{OH}	Output High Voltage	PWR = 5.5 V	--	--	PWR	V
V _{OL}	Output Low Voltage	PWR = 5.5 V	--	--	0.08	V
I _{OL}	Output Current Low	PWR = 5.5 V	--	--	20	mA
V _I	Input Voltage Level Range	Based on PWR setup	-0.2	--	PWR+0.2	V
V _{IH}	Input High Voltage		0.7 x PWR	--	--	V
V _{IL}	Input Low Voltage		--	--	0.3 x PWR	V
C _{IN}	Input Capacitance		--	20	--	pF

2.4 Advanced In-System Programming Connector

Advanced ISP connector is used for GreenPAK integrated circuits with SPI, I2C, and JTAG interfaces. E_VDD is a configurable power source. It can also be set as voltage reference input to synchronize voltage level with external circuit. E_VDD source/reference setup, output voltage, connection between TP and E_TP are controlled in Go Configure Software Hub. KEY is used for software detection. Go Configure setup for this connector should be the same as for Expansion connector.

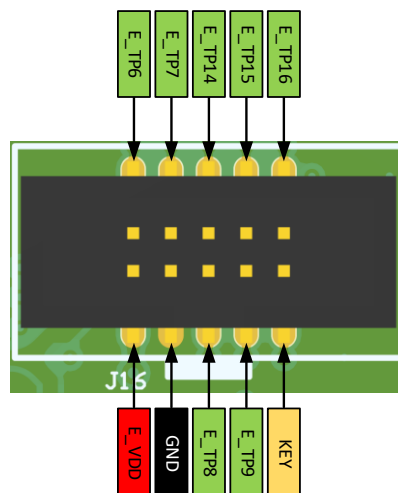

Figure 22. Advanced ISP Connector Pinout

2.4.1. Advanced In-System Programming Connector Specifications

E_VDD and all E_TPs have the same specifications as for the Expansion connector. [Table 8](#) describes specifications for KEY pin.

Table 8. KEY Specifications

Parameter	Description	Condition	Min	Typ	Max	Unit
V _{PULL}	Pull-up Voltage		--	5	--	V
R _{PULL}	Pull-up Resistance		--	10	--	kΩ
V _I	Input Voltage Level Range		-0.2	--	5	V
V _{IH}	Input High Voltage		3.5	--	--	V
V _{IL}	Input Low Voltage		--	--	1.5	V
C _{IN}	Input Capacitance		--	20	--	pF

3. Additional Features

3.1 LED Indication

LED state indication option is available for all TPs except TP1 (VDD) and TP10 (GND). Note that input thresholds for LED are the same as in Test Point input specification. If dual VDD GreenPAK is used and VDD2 voltage value is less than $VDD1 \cdot 0.7$ – indication can work incorrectly because input high threshold will never be reached. [Figure 23](#) shows LED indication configuration in Go Configure Software.

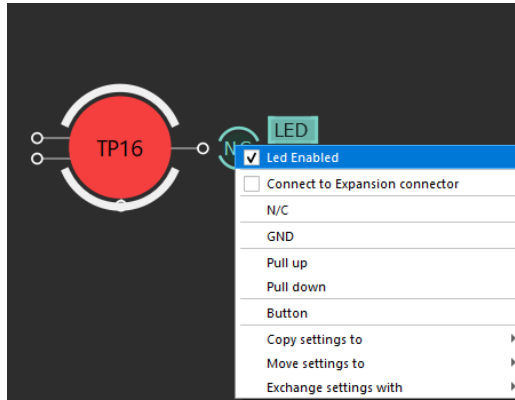

Figure 23. TP LED Indication Configuration

3.2 Probe Connection

[Figure 24](#) demonstrates current meter connection example. Jumper that connects VDD to VDD_A should be removed; probe hooks are connected to jumper pins through jumper wire. Note that some GreenPAKs have high startup current and auto range on current meter can cause sufficient VDD drop. In this case, emulation or programming will be unsuccessful. [Figure 25](#) shows oscilloscope connection. In this case Expansion connector must be enabled in Go Configure Software.

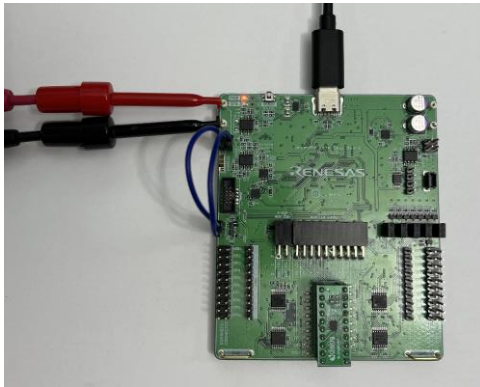

Figure 24. Current Meter Connection

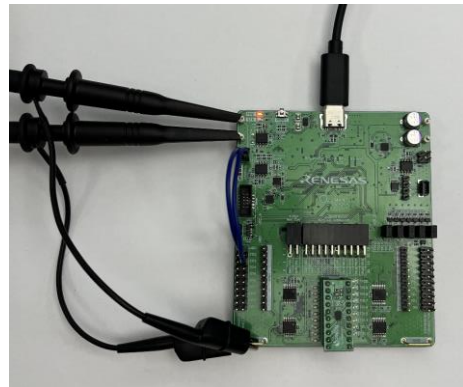

Figure 25. Oscilloscope Connection

3.3 Board Status Indication

The board has LEDs to display and indicate the status of some blocks of the entire system. Description of LED signals is shown in [Table 9](#).

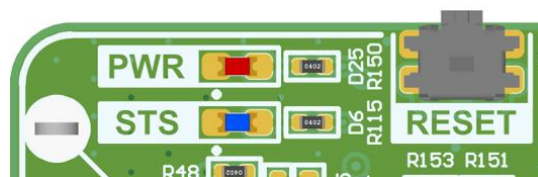

Figure 26. Board Status Indication and RESET Button

Table 9. LED Signals Description

PWR	STS	Event
ON	ON	Data transmission
ON	OFF	Board in standby mode
BLINK	OFF	Board power fail
OFF	BLINK	Ready to connect with software
OFF	OFF	Not connected to USB

3.4 Reset Button and Firmware Update

GreenPAK Lite Development Board has a RESET button. It is not necessary to unplug the board from USB for detach action. This can be done with a short time press on RESET button. This button allows to reboot the board or put it into boot mode. Short press on the button – resets the board, long press (press and hold for 2 seconds) – board enters boot mode and can update firmware from the Go Configure Software Hub.

To update firmware:

1. Insert the board.
2. Open Go Configure Software Hub software.
3. Open the existing project or create a new one.
4. Select Debug → GreenPAK Lite Development Platform → OK.
5. Press and hold RESET button for 2 seconds. When board enters boot mode, PWR LED will be automatically disabled. Then release the button.
6. Go Configure Software Hub should open a new window – Firmware selector.

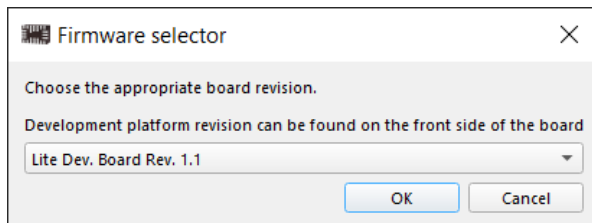

7. Click OK and receive the message.
8. Press on RESET button or reconnect the board to continue.
9. Firmware update procedure is finished.

Software should automatically recognize board revision in firmware selection window. Actual revision location is shown in [Figure 27](#).

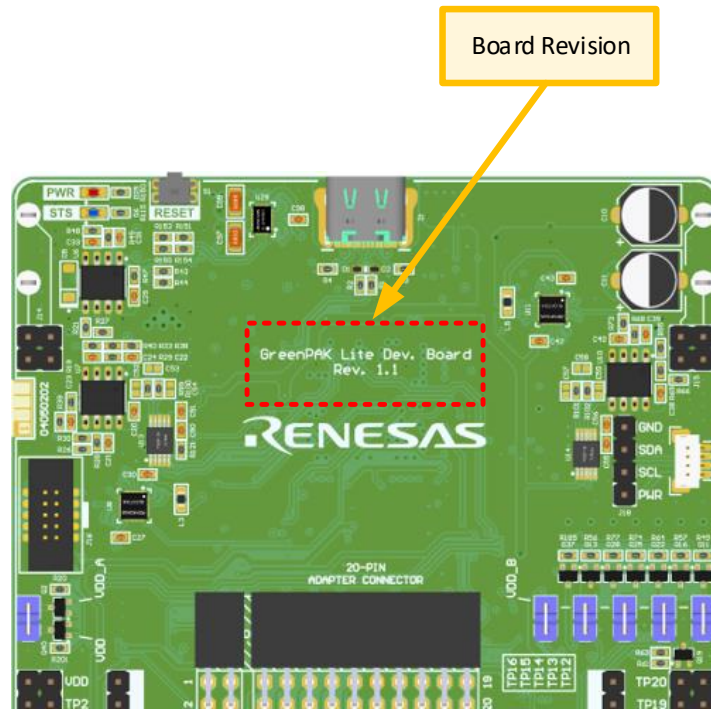

Figure 27. Board Revision Location

4. Ordering Information

Part Number	Description
SLG4DVKLITE	GreenPAK Lite Development Board R1.1

5. Revision History

Revision	Date	Description
1.00	Oct 20, 2023	Initial release.