

E8a Emulator

Additional Document for User's Manual
Notes on Connecting the H8/300H Super Low Power Series
R0E00008AKCE00EP63

Supported Devices:

H8 Family / H8/300H Super Low Power Series

H8/38076RF, H8/38086RF, H8/38776F, H8/38602RF, H8/38606F,

H8/38099F, H8/38799F, H8/38524F, H8/38537F, and H8/38704F

All information contained in these materials, including products and product specifications, represents information on the product at the time of publication and is subject to change by Renesas Electronics Corporation without notice. Please review the latest information published by Renesas Electronics Corporation through various means, including the Renesas Electronics Corporation website (<http://www.renesas.com>).

Notice

1. All information included in this document is current as of the date this document is issued. Such information, however, is subject to change without any prior notice. Before purchasing or using any Renesas Electronics products listed herein, please confirm the latest product information with a Renesas Electronics sales office. Also, please pay regular and careful attention to additional and different information to be disclosed by Renesas Electronics such as that disclosed through our website.
 2. Renesas Electronics does not assume any liability for infringement of patents, copyrights, or other intellectual property rights of third parties by or arising from the use of Renesas Electronics products or technical information described in this document. No license, express, implied or otherwise, is granted hereby under any patents, copyrights or other intellectual property rights of Renesas Electronics or others.
 3. You should not alter, modify, copy, or otherwise misappropriate any Renesas Electronics product, whether in whole or in part.
 4. Descriptions of circuits, software and other related information in this document are provided only to illustrate the operation of semiconductor products and application examples. You are fully responsible for the incorporation of these circuits, software, and information in the design of your equipment. Renesas Electronics assumes no responsibility for any losses incurred by you or third parties arising from the use of these circuits, software, or information.
 5. When exporting the products or technology described in this document, you should comply with the applicable export control laws and regulations and follow the procedures required by such laws and regulations. You should not use Renesas Electronics products or the technology described in this document for any purpose relating to military applications or use by the military, including but not limited to the development of weapons of mass destruction. Renesas Electronics products and technology may not be used for or incorporated into any products or systems whose manufacture, use, or sale is prohibited under any applicable domestic or foreign laws or regulations.
 6. Renesas Electronics has used reasonable care in preparing the information included in this document, but Renesas Electronics does not warrant that such information is error free. Renesas Electronics assumes no liability whatsoever for any damages incurred by you resulting from errors in or omissions from the information included herein.
 7. Renesas Electronics products are classified according to the following three quality grades: "Standard", "High Quality", and "Specific". The recommended applications for each Renesas Electronics product depends on the product's quality grade, as indicated below. You must check the quality grade of each Renesas Electronics product before using it in a particular application. You may not use any Renesas Electronics product for any application categorized as "Specific" without the prior written consent of Renesas Electronics. Further, you may not use any Renesas Electronics product for any application for which it is not intended without the prior written consent of Renesas Electronics. Renesas Electronics shall not be in any way liable for any damages or losses incurred by you or third parties arising from the use of any Renesas Electronics product for an application categorized as "Specific" or for which the product is not intended where you have failed to obtain the prior written consent of Renesas Electronics. The quality grade of each Renesas Electronics product is "Standard" unless otherwise expressly specified in a Renesas Electronics data sheets or data books, etc.

"Standard": Computers; office equipment; communications equipment; test and measurement equipment; audio and visual equipment; home electronic appliances; machine tools; personal electronic equipment; and industrial robots.

"High Quality": Transportation equipment (automobiles, trains, ships, etc.); traffic control systems; anti-disaster systems; anti-crime systems; safety equipment; and medical equipment not specifically designed for life support.

"Specific": Aircraft; aerospace equipment; submersible repeaters; nuclear reactor control systems; medical equipment or systems for life support (e.g. artificial life support devices or systems), surgical implantations, or healthcare intervention (e.g. excision, etc.), and any other applications or purposes that pose a direct threat to human life.
 8. You should use the Renesas Electronics products described in this document within the range specified by Renesas Electronics, especially with respect to the maximum rating, operating supply voltage range, movement power voltage range, heat radiation characteristics, installation and other product characteristics. Renesas Electronics shall have no liability for malfunctions or damages arising out of the use of Renesas Electronics products beyond such specified ranges.
 9. Although Renesas Electronics endeavors to improve the quality and reliability of its products, semiconductor products have specific characteristics such as the occurrence of failure at a certain rate and malfunctions under certain use conditions. Further, Renesas Electronics products are not subject to radiation resistance design. Please be sure to implement safety measures to guard them against the possibility of physical injury, and injury or damage caused by fire in the event of the failure of a Renesas Electronics product, such as safety design for hardware and software including but not limited to redundancy, fire control and malfunction prevention, appropriate treatment for aging degradation or any other appropriate measures. Because the evaluation of microcomputer software alone is very difficult, please evaluate the safety of the final products or system manufactured by you.
 10. Please contact a Renesas Electronics sales office for details as to environmental matters such as the environmental compatibility of each Renesas Electronics product. Please use Renesas Electronics products in compliance with all applicable laws and regulations that regulate the inclusion or use of controlled substances, including without limitation, the EU RoHS Directive. Renesas Electronics assumes no liability for damages or losses occurring as a result of your noncompliance with applicable laws and regulations.
 11. This document may not be reproduced or duplicated, in any form, in whole or in part, without prior written consent of Renesas Electronics.
 12. Please contact a Renesas Electronics sales office if you have any questions regarding the information contained in this document or Renesas Electronics products, or if you have any other inquiries.
- (Note 1) "Renesas Electronics" as used in this document means Renesas Electronics Corporation and also includes its majority-owned subsidiaries.
- (Note 2) "Renesas Electronics product(s)" means any product developed or manufactured by or for Renesas Electronics.

Regulatory Compliance Notices

European Union regulatory notices

This product complies with the following EU Directives. (These directives are only valid in the European Union.)

CE Certifications:

- Electromagnetic Compatibility (EMC) Directive 2004/108/EC

EN 55022 Class A

WARNING: This is a Class A product. In a domestic environment this product may cause radio interference in which case the user may be required to take adequate measures.

EN 55024

- Information for traceability
 - Authorised representative

Name: Renesas Electronics Corporation

Address: 1753, Shimonomabe, Nakahara-ku, Kawasaki, Kanagawa, 211-8668, Japan

- Manufacturer

Name: Renesas Solutions Corp.

Address: Nippon Bldg., 2-6-2, Ote-machi, Chiyoda-ku, Tokyo 100-0004, Japan

- Person responsible for placing on the market

Name: Renesas Electronics Europe Limited

Address: Dukes Meadow, Millboard Road, Bourne End, Buckinghamshire, SL8 5FH, U.K.

Environmental Compliance and Certifications:

- Waste Electrical and Electronic Equipment (WEEE) Directive 2002/96/EC

WEEE Marking Notice (European Union Only)



Renesas development tools and products are directly covered by the European Union's Waste Electrical and Electronic Equipment, (WEEE), Directive 2002/96/EC. As a result, this equipment, including all accessories, must not be disposed of as household waste but through your locally recognized recycling or disposal schemes. As part of our commitment to environmental responsibility Renesas also offers to take back the equipment and has implemented a Tools Product Recycling Program for customers in Europe. This allows you to return equipment to Renesas for disposal through our approved Producer Compliance Scheme. To register for the program, click here "<http://www.renesas.com/weee>".

United States Regulatory notices on Electromagnetic compatibility

FCC Certifications (United States Only):

This equipment has been tested and found to comply with the limits for a Class A digital device, pursuant to Part 15 of the FCC Rules. These limits are designed to provide reasonable protection against harmful interference when the equipment is operated in a commercial environment. This equipment generates, uses, and can radiate radio frequency energy and, if not installed and used in accordance with the instruction manual, may cause harmful interference to radio communications. Operation of this equipment in a residential area is likely to cause harmful interference in which case the user will be required to correct the interference at his own expense.

CAUTION: Changes or modifications not expressly approved by the party responsible for compliance could void the user's authority to operate the equipment.

Table of Contents

Notes on Connecting the H8/38076RF, H8/38086RF, and H8/38776F	1
Section 1 Inside the E8a Emulator User's Manual	3
Section 2 Connecting the Emulator with the User System	5
Section 3 Pin Assignments of the E8a Connector	7
Section 4 Example of Emulator Connection.....	9
Section 5 Differences between the MCUs (H8/38076RF, H8/38086RF, and H8/38776F) and the Emulator	15
Notes on Connecting the H8/38602RF and H8/38606F.....	1
Section 1 Inside the E8a Emulator User's Manual	3
Section 2 Connecting the Emulator with the User System	5
Section 3 Pin Assignments of the E8a Connector	7
Section 4 Example of Emulator Connection.....	9
Section 5 Differences between the MCUs (H8/38602RF and H8/38606F) and the Emulator	15
Notes on Connecting the H8/38099F and H8/38799F.....	1
Section 1 Inside the E8a Emulator User's Manual	3
Section 2 Connecting the Emulator with the User System	5
Section 3 Pin Assignments of the E8a Connector	7
Section 4 Example of Emulator Connection.....	9
Section 5 Differences between the MCUs (H8/38099F and H8/38799F) and the Emulator.....	15
Notes on Connecting the H8/38524F.....	1
Section 1 Inside the E8a Emulator User's Manual	3
Section 2 Connecting the Emulator with the User System	5
Section 3 Pin Assignments of the E8a Connector	7
Section 4 Example of Emulator Connection.....	9
Section 5 Differences between the MCU (H8/38524F) and the Emulator	15
Notes on Connecting the H8/38537F.....	1
Section 1 Inside the E8a Emulator User's Manual	3
Section 2 Connecting the Emulator with the User System	5

Section 3	Pin Assignments of the E8a Connector	7
Section 4	Example of Emulator Connection.....	9
Section 5	Differences between the MCU (H8/38537F) and the Emulator	13
Notes on Connecting the H8/38704F.....		1
Section 1	Inside the E8a Emulator User's Manual	3
Section 2	Connecting the Emulator with the User System	5
Section 3	Pin Assignments of the E8a Connector	7
Section 4	Example of Emulator Connection.....	9
Section 5	Differences between the MCU (H8/38704F) and the Emulator	13

Note: This manual applies to the following product versions of the E8a emulator software.

Table E8a Emulator Software

<p>E8a Emulator V.1.05 Release 00 or later (H8 Tiny/Super Low Power E8a Emulator V.1.03.00 or later)*</p>
--

Note: This is a revision of the debugger.

Notes on Connecting the H8/38076RF, H8/38086RF, and H8/38776F

Section 1 Inside the E8a Emulator User's Manual

The E8a emulator (hereafter referred to as E8a in this document) manual consists of two documents: the E8a User's Manual and the E8a Additional Document for User's Manual (this document). Be sure to read BOTH documents before using the E8a emulator.

(1) E8a Emulator User's Manual

The E8a Emulator User's Manual describes the hardware specifications and how to use the emulator debugger.

- E8a emulator hardware specifications
- Connecting the E8a emulator to the host computer or user system
- Operating the E8a emulator debugger
- Tutorial: From starting up the E8a emulator debugger to debugging

(2) E8a Additional Document for User's Manual

The E8a Additional Document for User's Manual describes content dependent on the MCUs and precautionary notes.

- Example of the E8a emulator connection or interface circuit necessary for designing the hardware
- Notes on using the E8a emulator
- Setting the E8a emulator debugger during startup

Section 2 Connecting the Emulator with the User System

Before connecting an E8a emulator (hereafter referred to as emulator) with the user system, a connector must be installed in the user system so that a user system interface cable can be connected. When designing the user system, refer to the connector and recommended circuits shown in this manual.

Before designing the user system, be sure to read the E8a emulator user's manual and the hardware manual for related MCUs.

Table 2.1 shows the recommended connector for the emulator.

Table 2.1 Recommended Connector

Type Number	Manufacturer	Specifications
2514-6002	3M Limited	14-pin straight type

Connect pins 2, 4, 6, 10, 12, and 14 of the user system connector to GND firmly on the PCB. These pins are used as electrical GND and to monitor the connection of the user system connector. Note the pin assignments of the user system connector.

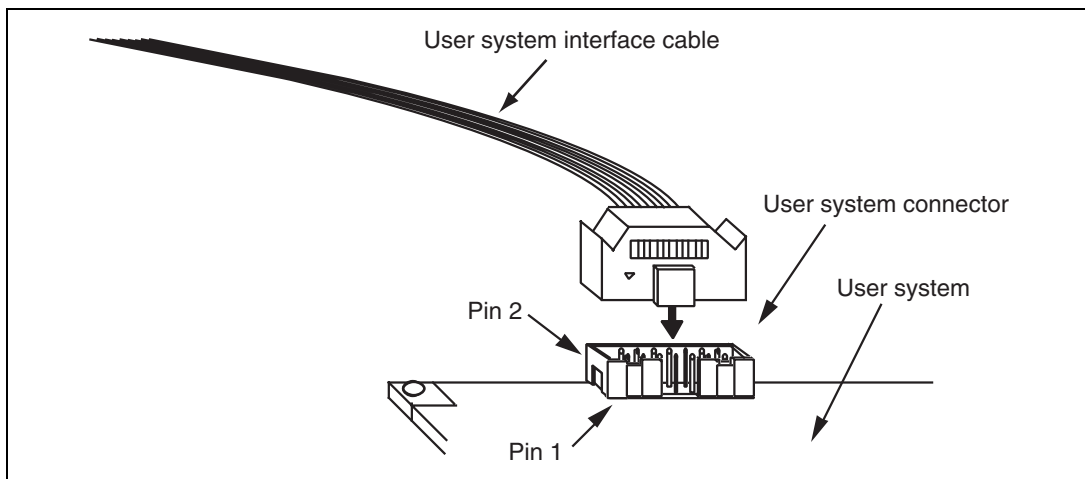

Figure 2.1 Connecting the User System Interface Cable to the User System

- Notes:
1. The pin number assignments of the 14-pin connector differ from those of the E10A-USB emulator; however, the physical location is the same.
 2. Do not place any components within 3 mm of the connector.
 3. When the emulator is used in the [Program Flash] mode, connect the emulator similarly to the user system.

Section 3 Pin Assignments of the E8a Connector

Figure 3.1 shows the pin assignments of the connector.

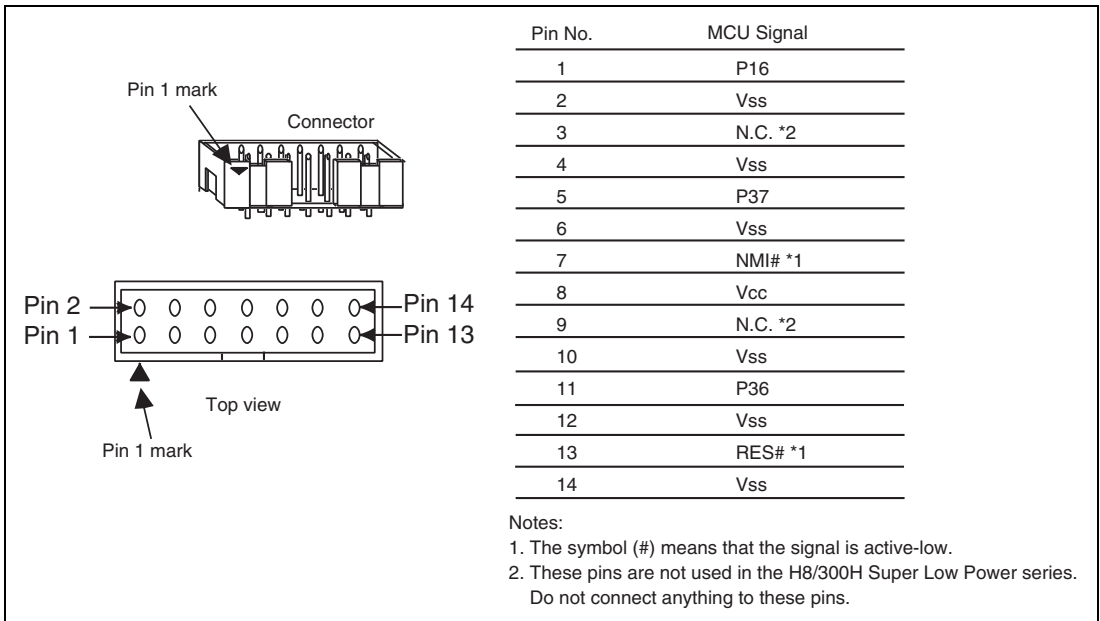

Figure 3.1 Pin Assignments of the Connector

Section 4 Example of Emulator Connection

Figure 4.1 shows an example of emulator connection to the MCU.

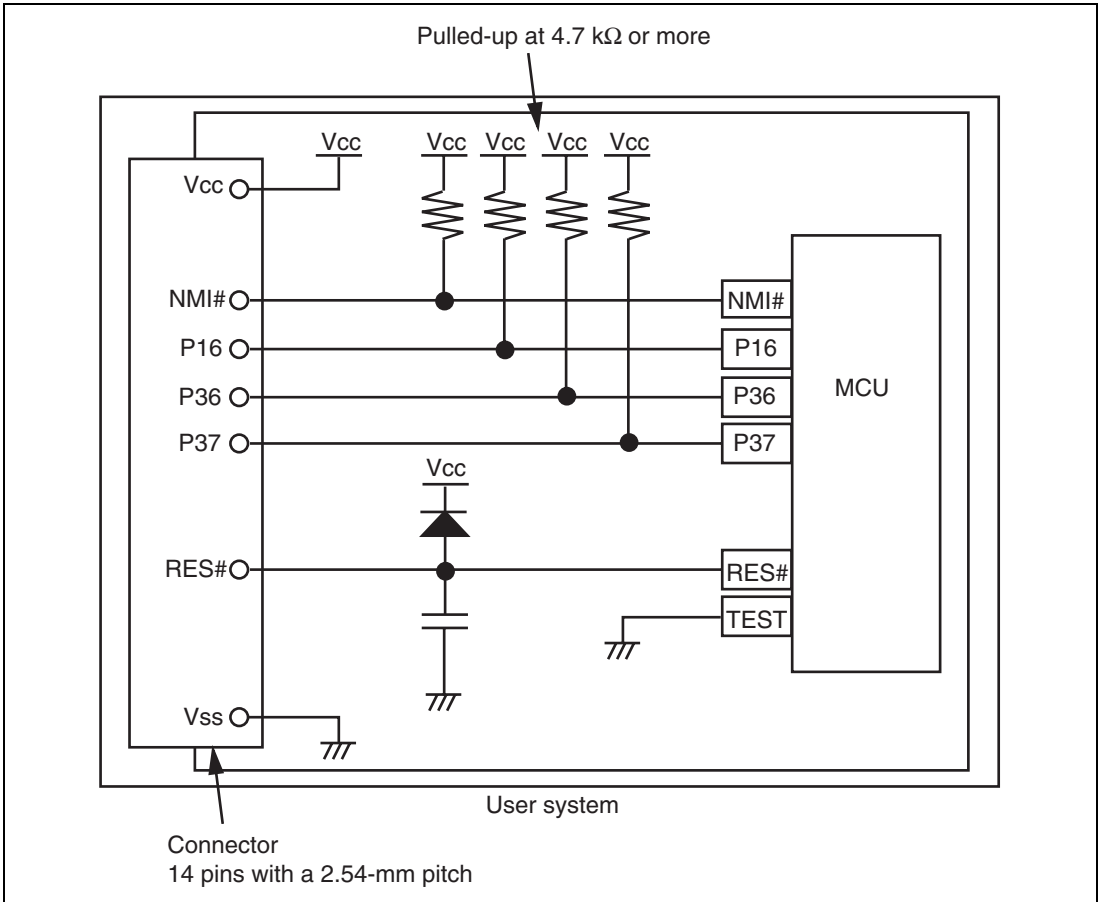

Figure 4.1 Example of Emulator Connection

Notes: 1. P16, P36, and P37 pins are used by the emulator. Pull up and connect the emulator and MCU pins.

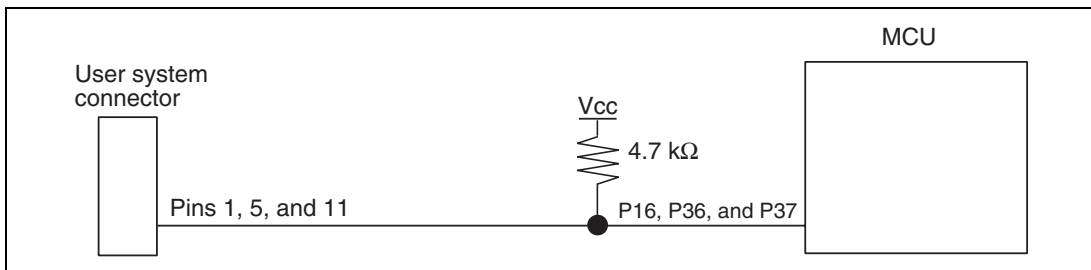

Figure 4.2 Connection of Emulator and P16, P36, and P37 Pins

2. The NMI# signal is used for forced break control by the emulator. Connect the emulator and MCU pins directly. In debugging without forced break control, change the mode with the High-performance Embedded Workshop. Then, when the user logic is connected with the open-collector output buffer, the NMI# pin can be used in the user system (however, at power-on, the NMI# pin is used by the emulator).

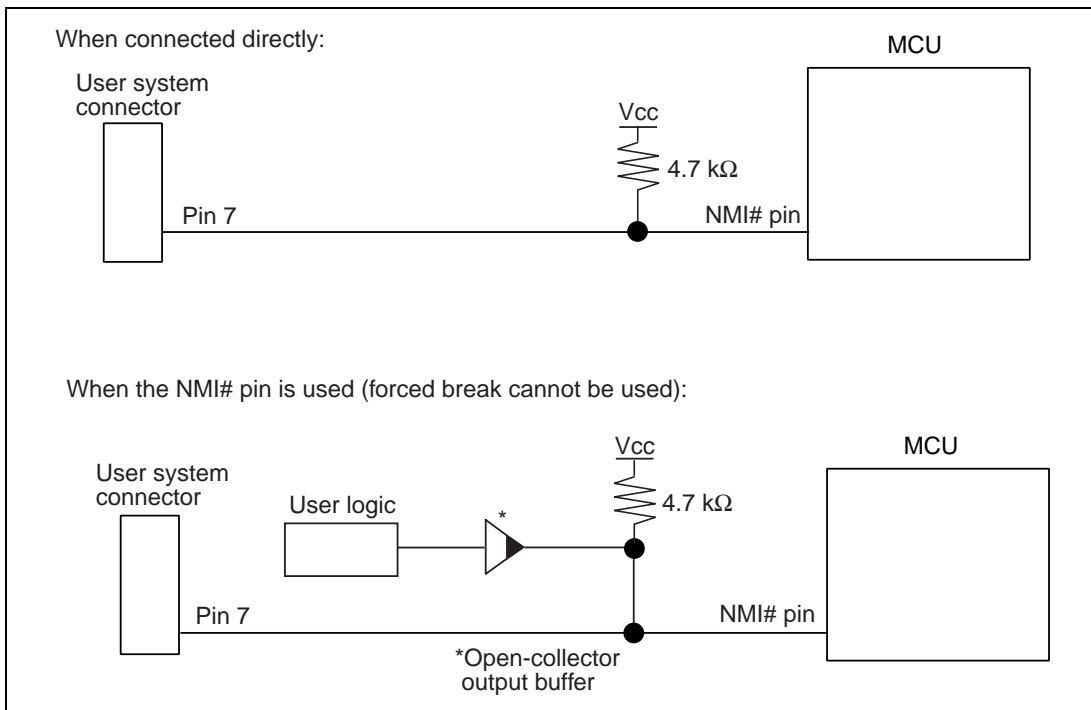

Figure 4.3 Connection of Emulator and NMI# Pin

- The RES# pin is used by the emulator. Create the following circuit so that reset input can be accepted from the emulator.

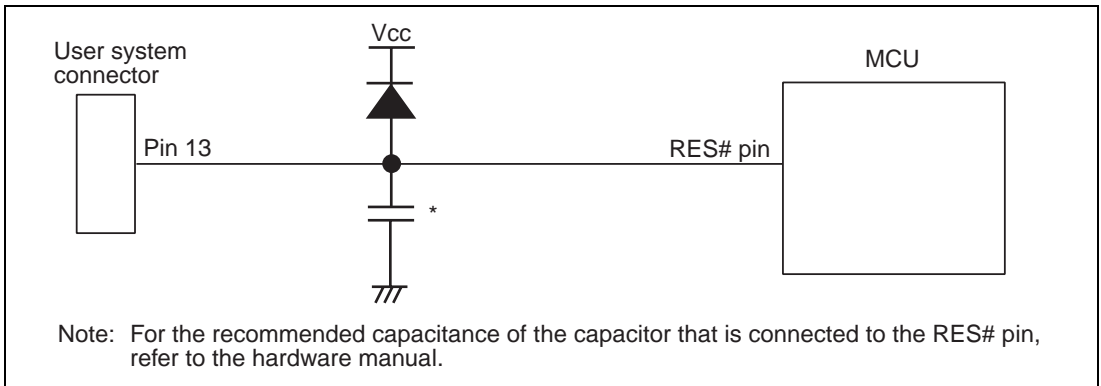

Figure 4.4 Example of a Reset Circuit

- Connect Vss and Vcc with the Vss and Vcc of the MCU, respectively (within the guaranteed range of the microcomputer).
When the power-supply mode is used, the power is supplied to the user system. Check that the power consumption or voltage of the user system is within the available range of E8a and avoid a problem such as closing of the power-supply circuit.
- Connect nothing with N.C.
- When the emulator is connected to the user system, ground the TEST pin of the MCU.

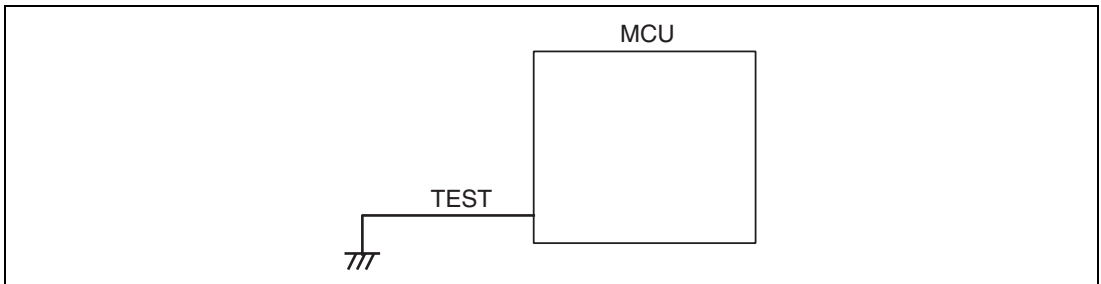

Figure 4.5 Emulator and the TEST Pin

Note: When the emulator is connected, ADTRG#, which is also used as the TEST pin, cannot be used.



WARNING

In the power-supply mode, connect the emulator after checking that the power-supply circuit on the user system is not closed or the pin number assignments of the user system connector is correct.

Failure to do so will result in a FIRE HAZARD and will damage the host computer, the emulator, and the user system.

- When the MCU in use is connected to the emulator, the pin functions listed below are not available.

Table 4.1 Pin Functions Not Available

H8/38076RF, H8/38086RF, and H8/38776F

P16, P36, and P37

NMI# (normal)

ADTRG#

- Figure 4.6 shows the interface circuit in the E8a emulators. Use this figure as a reference when determining the pull-up resistance value.

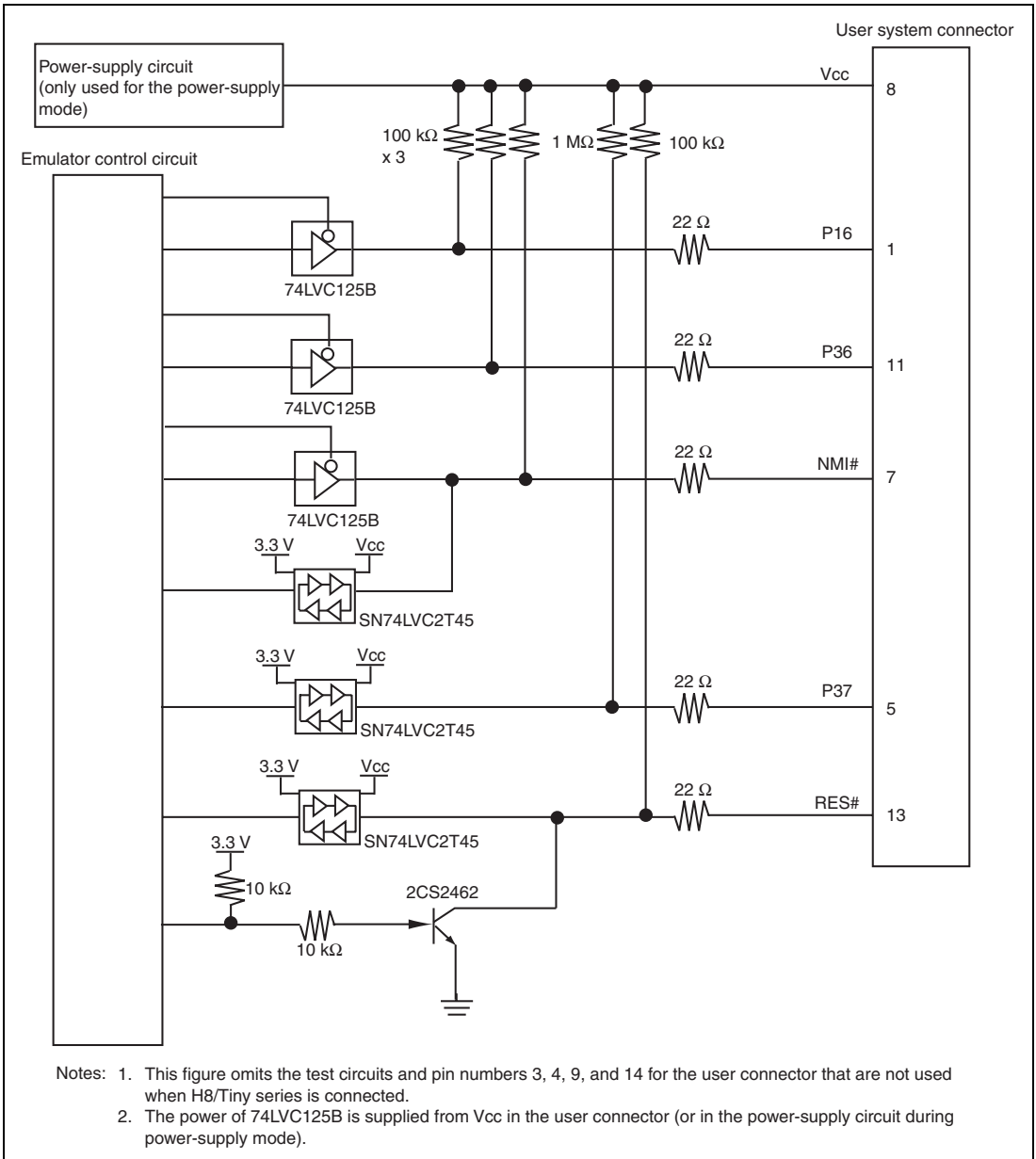

Figure 4.6 Interface Circuit in the E8a Emulator (Reference)

Section 5 Differences between the MCUs (H8/38076RF, H8/38086RF, and H8/38776F) and the Emulator

This section describes the differences between the emulator and MCU operations.

1. [Emulator Setting] Dialog Box

The [Emulator Setting] dialog box is provided for setting the items that need to be set when the emulator starts up (settings are saved in the session).

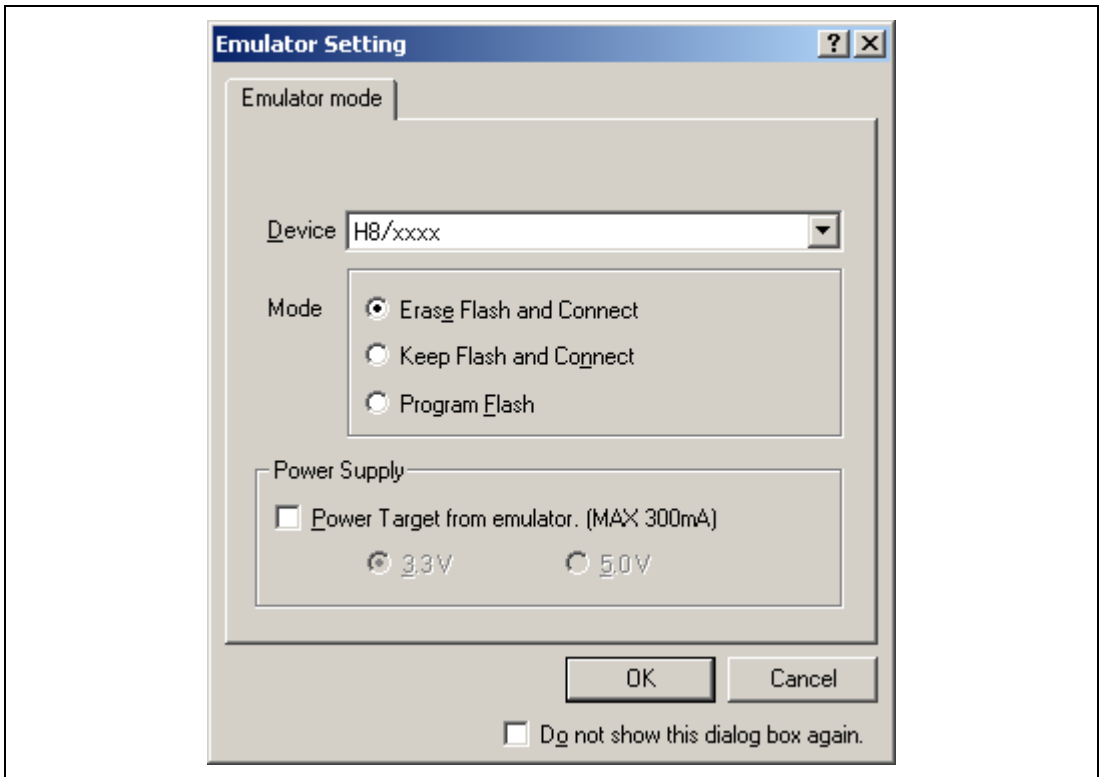

Figure 5.1 [Emulator Setting] Dialog Box

To keep the [Emulator Setting] dialog box closed next time the emulator is started, check "Do not show this dialog box again." at the bottom of the [Emulator Setting] dialog box. You can open the [Emulator Setting] dialog box using either one of the following methods:

- After the emulator gets started, select Menu - [Setup] -> [Emulator] -> [Emulator Setting...].
- Start the emulator while holding down the Ctrl key.
- After the emulator gets started and an error occurred, restart the emulator.

When you check "Do not show this dialog box again.", the emulator doesn't supply power to the user system. To use this check box, start the emulator after turning on the power.

2. Emulator Mode

The selection of the device, the specification of the mode, and the setting of the power supply are done in the [Emulator mode] page of the [Emulator Setting] dialog box.

— Device

Select the device name in use from the [Device] combo box. The following items are selected in the [Mode] group box.

— Modes

- Erase Flash and Connect

This mode is used when there is no emulator program in the flash memory of the target device. In this mode, data of the flash memory of the target device is erased when the emulator is activated. Select this item when the emulator is firstly activated, the version of the emulator's software is updated, or the ID code is changed.

- Keep Flash and Connect

This mode is used when there is an emulator program in the flash memory of the target device. Enter the ID code specified above ('Erase Flash and Connect'). If an incorrect code is entered, all the programs on the flash memory will be erased.

Note: When the emulator gets started in this mode after selecting "Do not show this dialog box again.", the initial values of the ID code is '0E8a' for the E8a emulator. If you use the ID code other than the initial value, do not use "Do not show this dialog box again."

- Program Flash

This mode is used when the emulator is used for programming the flash memory. Debugging the program is disabled. To download the load module, register it in the workspace.

Note: In the H8/Tiny or H8/Super Low Power device, the ID code is not entered in the Program Flash mode.

- Power Supply

When [Power Target from emulator. (MAX 300mA)] is checked, power will be supplied to the user system up to 300 mA. Then select 3.3 V or 5.0 V according to the power voltage of the user system.

3. Emulator Activation and ID Code

In the H8/Tiny- or H8/Super Low Power-series MCU, the [System Clock] and [ID Code] dialog boxes are set when the emulator is activated.

- Setting the system clock

Enter the clock value input to the board in use. The initial value differs in each MCU.

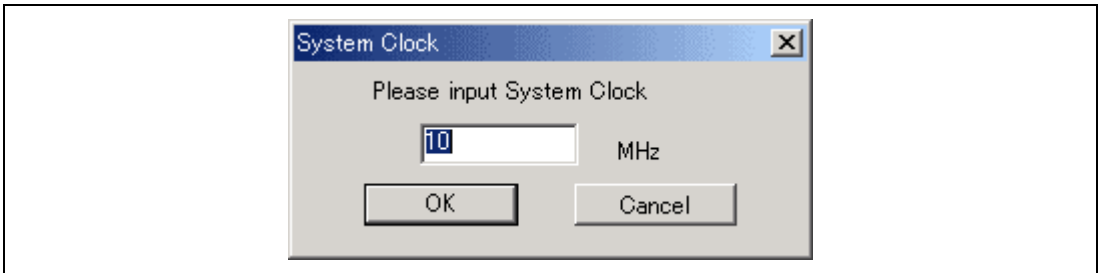

Figure 5.2 [System Clock] Dialog Box

- Setting the ID code

When the emulator is activated in the [Erase Flash and Connect] mode, enter any hexadecimal four-digit ID code to be set (except for H'FFFF). The initial value is H'0E8A. When the emulator is activated in the [Keep Flash and Connect] mode, enter the correct ID code. If an incorrect ID code is entered, all the contents of the flash memory will be erased. In this case, restart the emulator in the [Erase Flash and Connect] mode.

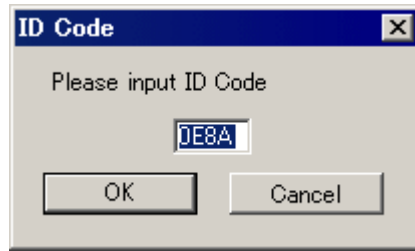

Figure 5.3 [ID Code] Dialog Box

4. When the emulator system is initiated, it initializes the general registers and part of the control registers as shown in table 5.1.

Table 5.1 Register Initial Values at Emulator Power-On

Register	Initial Value
PC	Reset vector value in the vector address table
ER0 to ER6	H'0000
ER7	H'FF80
CCR	H'80

5. Low-Power Mode

During a user program break, the CPU operating frequency is forced to a system clock (ϕ) for high-speed operation.

6. RES# Signal

The RES# signal is only valid during user program execution started with clicking the GO or STEP-type button. During a user program break, the RES# signal is not sent to the MCUs.

Note: Do not start user program execution or access the memory while control input signal (RES#) is being low. A TIMEOUT error will occur.

7. System Control Register

In the emulator, the internal I/O registers can be accessed from the [IO] window. However, be careful when accessing the system control register. The emulator saves the register value of the system control register at a break and returns the value when the user program is executed. Since this is done during a break, do not rewrite the system control register in the [IO] window.

8. Memory Access during Emulation

If the memory contents are referenced or modified during emulation, realtime emulation cannot be performed because the user program is temporarily halted.

9. The emulator communicates with the MCUs by using the NMI#, RES#, P16, P36, and P37 pins. These pins cannot be used, however, the NMI# pin can be used by changing the setting of the [NMI signal] group box in the [Configuration] dialog box.

10. Sum Data Displayed in the Program Flash Mode

Sum data, which is displayed in the 'Program Flash' mode, is a value that data in the whole ROM areas has been added by byte (including data in the dedicated ROM area for the emulator).

11. Note on Executing the User Program

The set value is rewritten since the emulator uses flash memory and watchdog timer registers during programming (Go, Step In, Step Out, or Step Over) of the flash memory.

12. The power consumed by the MCU can reach several milliamperes. This is because the user power supply drives ICs to make the communication signal level match the user-system power-supply voltage. The power consumed rises little during user program execution since the emulator does not perform communication; it rises more during a break.

13. Program Area for the Emulator

Do not access a part of areas in the flash memory or the internal RAM since the emulator program uses these areas. If the contents of the program area for the emulator are changed, the emulator will not operate normally. In this case, restart the emulator with the Erase Flash and Connect mode.

Table 5.2 Program Area for the E8a Emulator

MCU Name	Program Area
H8/38076RF	Emulator ROM: H'C000 to H'CFFF
H8/38086RF	Internal RAM: H'F380 to H'F77F
H8/38776F	Vector, etc.: H'0002 to H'0009, H'CFF8 to H'CFF9

14. The emulator uses a two-word stack pointer for values stored on a user program break. Therefore, the stack area must accept two-word addresses.

15. Do not use an MCU that has been used for debugging.

If the flash memory is rewritten many times, data may be lost due to retention problems after the emulator has been left for a few days and the data will be erased. If an error message is displayed, exchange the MCU for a new one.

16. Forced Break Function

When the NMI# signal is used for a forced break in the emulator, the vector address of NMI# is rewritten by the emulator program. An error will occur if a file in the host computer and the flash memory contents are verified. Do not use the flash memory contents as the ROM data for the mask ROM after it has been saved.

17. Setting the Usage of the NMI# Signal

In the [Configuration] dialog box, when the NMI# signal is changed as it is used in the user program, the vector address of NMI# is not recovered. Reload the user program.

18. Address Break Release Function

In the [Configuration] dialog box, when the address break is changed as it is used in the user program, Break Condition 2 is disabled in this emulator.

19. Hardware Break Functions

- In the H8/38076RF, H8/38086RF, H8/38776F E8a emulator, conditions of Break Condition 1,2 can be set. Table 5.3 lists the items that can be specified.

Note: When the address break is used in the user program, Break Condition 2 is disabled.

Table 5.3 Hardware Break Condition Specification Items

Items	Description
Address bus condition	Breaks when the MCU address bus value matches the specified value.
Data bus condition	Breaks when the MCU data bus value matches the specified value. High or low byte or word can be specified as the access data size.
Read or write condition	Breaks in the read or write cycle.

Table 5.4 lists the combinations of conditions that can be set in the [Break condition] dialog box.

Table 5.4 Conditions Set in [Break condition] Dialog Box

Dialog Box	Condition		
	Address Bus Condition	Data Condition	Read or Write Condition
[Break condition 1]	<input type="radio"/>	<input type="radio"/>	<input type="radio"/>
[Break condition 2]	<input type="radio"/>	<input type="radio"/>	<input type="radio"/>

Note: : Can be set by checking the radio button in the dialog box.

Table 5.5 lists the combinations of conditions that can be set by the BREAKCONDITION_SET command.

Table 5.5 Conditions Set by BREAKCONDITION_SET Command

Channel	Condition		
	Address Bus Condition (<addropt> option)	Data Condition (<dataopt> option)	Read or Write Condition (<r/wopt> option)
Break condition 1	<input type="radio"/>	<input type="radio"/>	<input type="radio"/>
Break condition 2	<input type="radio"/>	<input type="radio"/>	<input type="radio"/>

Note: : Can be set by the BREAKCONDITION_SET command.

- Notes on Setting the Break Condition
 1. When [Step In], [Step Over], or [Step Out] is selected, the settings of Break Condition are disabled.
 2. The settings of Break Condition are disabled when an instruction to which a BREAKPOINT has been set is executed.
 3. When step over function is used, the settings of BREAKPOINT and Break Condition are disabled.
 4. Do not make any setting that satisfies both Break Condition 2 and the BREAKPOINT or Break Condition 1. Otherwise, the break cause of Break Condition 2 is retained and a break will occur by executing no instruction when the user program execution is resumed.
 5. When Break Condition 2 is satisfied, the emulator uses the latest one branch of the branch trace information.
 6. Break Condition 2 causes no break when it has a conflict with a reset.

20. Items Set in the [Configuration] Dialog Box

The emulator operation conditions are set in the [Configuration] dialog box.

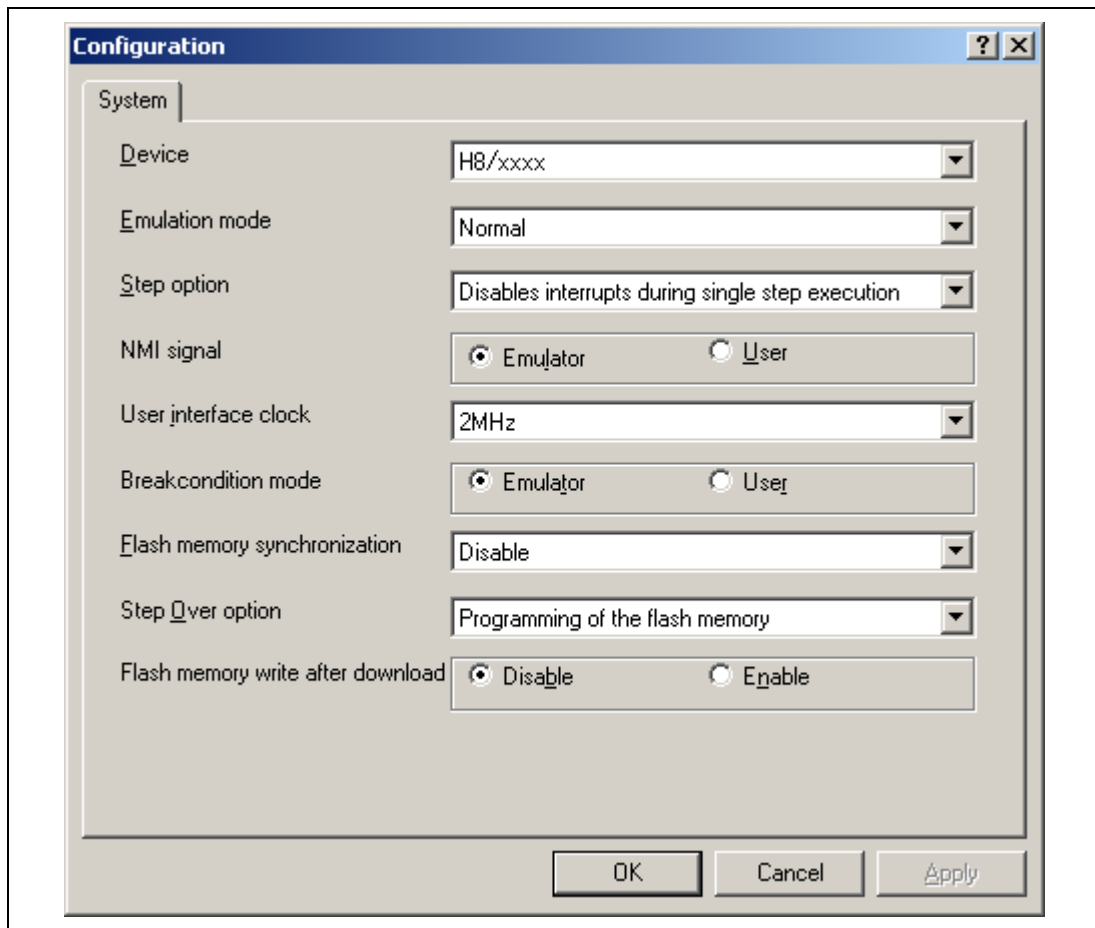

Figure 5.4 [Configuration] Dialog Box ([System] Page)

Items that can be displayed in this dialog box are listed below.

[Device] combo box	Displays the MCU name.
[Emulation mode] combo box	Selects the emulation mode at user program execution. Select Normal to perform normal emulation. Select No break to disable PC breakpoint or break condition settings during emulation.
[Step option] combo box	Sets the step interrupt option. Disable interrupts during single step execution: Disables interrupts ^{*1} during step execution. Enable interrupts during single step execution: Enables interrupts ^{*1} during step execution.
[NMI signal] group box	Sets the use of the NMI# signal. When used as a forced break in the emulator, select Emulator. In this case, the NMI# signal cannot be used. The contents of the NMI# vector address are rewritten by the emulator program. When used in the user program, select User. In this case, the forced break cannot be used. Before user program execution, set the breakpoints or break conditions for the exception processing and generate exceptions to halt the program.
[User interface clock] combo box	Displays the transfer clock of the user interface.
[Breakcondition mode] group box	Sets the address break release function. When the address break function is not used in the user program, select Emulator. In this case, the hardware break and step functions can be used. The contents of the vector address are rewritten by the emulator program to satisfy the break conditions. When the address break is used in the user program, select User. In this case, the hardware break function (Break Condition 2) cannot be used.
[Flash memory synchronization] combo box	Selects whether or not the contents of the flash memory are acquired by the emulator when the user program is stopped or the position where the PC break is set is put back as the original code. When the flash memory is not programmed by the user program, its contents need not be acquired by the emulator.

If there is no problem with the state that the program in the flash memory has been replaced as the PC break code, the position where the PC break is set needs not be put back as the original code.

Disable: Read or program is not performed for the flash memory except when the emulator is activated, the flash memory area is modified, and the settings of the PC break to the flash memory area are changed.

PC to flash memory: When the user program is stopped, the specified PC break code is replaced as the original instruction. Select this option if there is a problem with the state that the program in the flash memory has been replaced as the PC break code.

Flash memory to PC: When the user program is stopped, the contents of the flash memory are read by the emulator. Select this option if the flash memory is reprogrammed by the user program.

PC to flash memory, Flash memory to PC:

When the user program is stopped, the contents of the flash memory are read by the emulator and the specified PC break code is replaced as the original instruction. Select this option if the flash memory is reprogrammed by the user program and there is a problem with the state that the program in the flash memory has been replaced as the PC break code.

[Step Over option] combo box

Enables or disables programming of the flash memory while executing step operation.

Programming of the flash memory: Uses a software break for step operation (e.g. Step Over) and enables programming of the flash memory.

No Programming of the flash memory: Uses Break Condition for step operation (e.g. Step Over) and disables programming of the flash memory².

[Flash memory write after download] group box

Enables or disables programming of the flash memory after downloading the program.

Disable: Disables programming of the flash memory after downloading the program.

Enable: Enables programming of the flash memory after downloading the program.

- Notes:
1. Includes interrupts in a break.
 2. When Step Over is performed after selecting [No Programming of the flash memory] for [Step Over option], the instruction that follows a JSR, BSR, or TRAPA instruction will also be executed. If there are consecutive JSR, BSR, or TRAPA instructions, execution proceeds until it reaches an instruction that is not JSR, BSR, or TRAPA. (When there are consecutive function calls in C language, the program steps all of these functions.)

21. Initializing the Internal I/O Register with the Reset_CPU Function

Be sure to initialize the internal I/O registers shown below by the user program since they are not initialized by selecting [Debug] – [Reset CPU] or using the RESET command.

Table 5.6 Registers Not Initialized

MCU Name	Register Not Initialized
H8/38076RF	SYSCR1, SYSCR2, IEGR, INTM, IENR2, IENR1, IRR1, IRR2, IWPR,
H8/38086RF	CKSTPR1, CKSTPR2
H8/38776F	

Notes on Connecting the H8/38602RF and H8/38606F

Section 1 Inside the E8a Emulator User's Manual

The E8a emulator (hereafter referred to as E8a in this document) manual consists of two documents: the E8a User's Manual and the E8a Additional Document for User's Manual (this document). Be sure to read BOTH documents before using the E8a emulator.

(1) E8a Emulator User's Manual

The E8a Emulator User's Manual describes the hardware specifications and how to use the emulator debugger.

- E8a emulator hardware specifications
- Connecting the E8a emulator to the host computer or user system
- Operating the E8a emulator debugger
- Tutorial: From starting up the E8a emulator debugger to debugging

(2) E8a Additional Document for User's Manual

The E8a Additional Document for User's Manual describes content dependent on the MCUs and precautionary notes.

- Example of the E8a emulator connection or interface circuit necessary for designing the hardware
- Notes on using the E8a emulator
- Setting the E8a emulator debugger during startup

Section 2 Connecting the Emulator with the User System

Before connecting an E8a emulator (hereafter referred to as emulator) with the user system, a connector must be installed in the user system so that a user system interface cable can be connected. When designing the user system, refer to the connector and recommended circuits shown in this manual.

Before designing the user system, be sure to read the E8a emulator user's manual and the hardware manual for related MCUs.

Table 2.1 shows the recommended connector for the emulator.

Table 2.1 Recommended Connector

Type Number	Manufacturer	Specifications
2514-6002	3M Limited	14-pin straight type

Connect pins 2, 4, 6, 10, 12, and 14 of the user system connector to GND firmly on the PCB. These pins are used as electrical GND and to monitor the connection of the user system connector. Note the pin assignments of the user system connector.

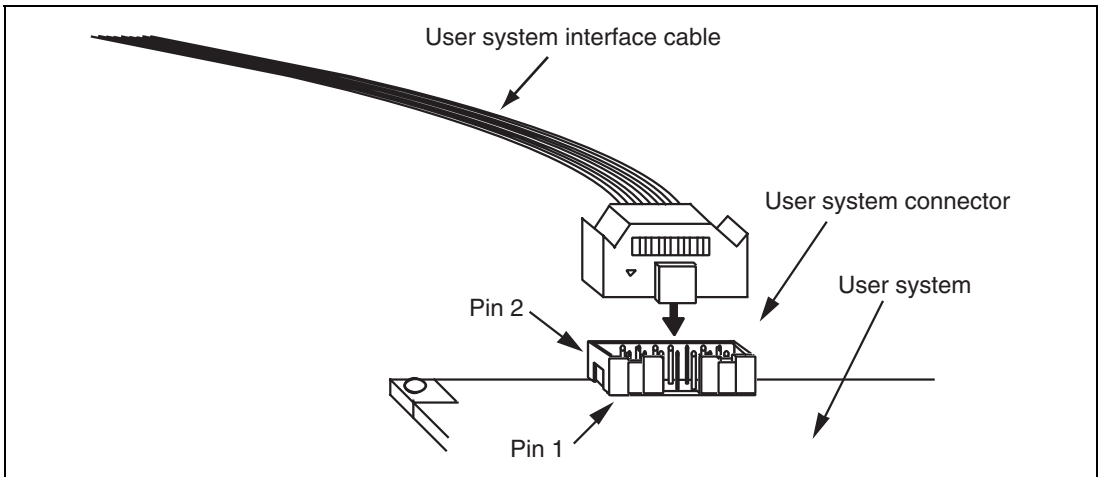

Figure 2.1 Connecting the User System Interface Cable to the User System

- Notes:
1. The pin number assignments of the 14-pin connector differ from those of the E10A-USB emulator; however, the physical location is the same.
 2. Do not place any components within 3 mm of the connector.
 3. When the emulator is used in the [Program Flash] mode, connect the emulator similarly to the user system.

Section 3 Pin Assignments of the E8a Connector

Figure 3.1 shows the pin assignments of the connector.

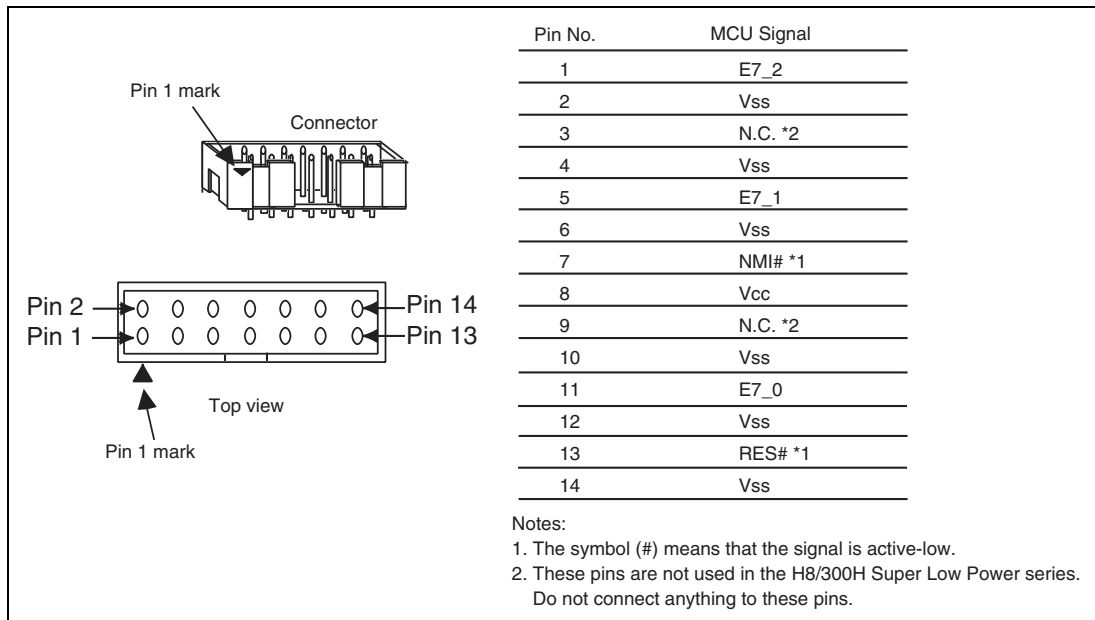

Figure 3.1 Pin Assignments of the Connector

Section 4 Example of Emulator Connection

Figure 4.1 shows an example of emulator connection to the MCU.

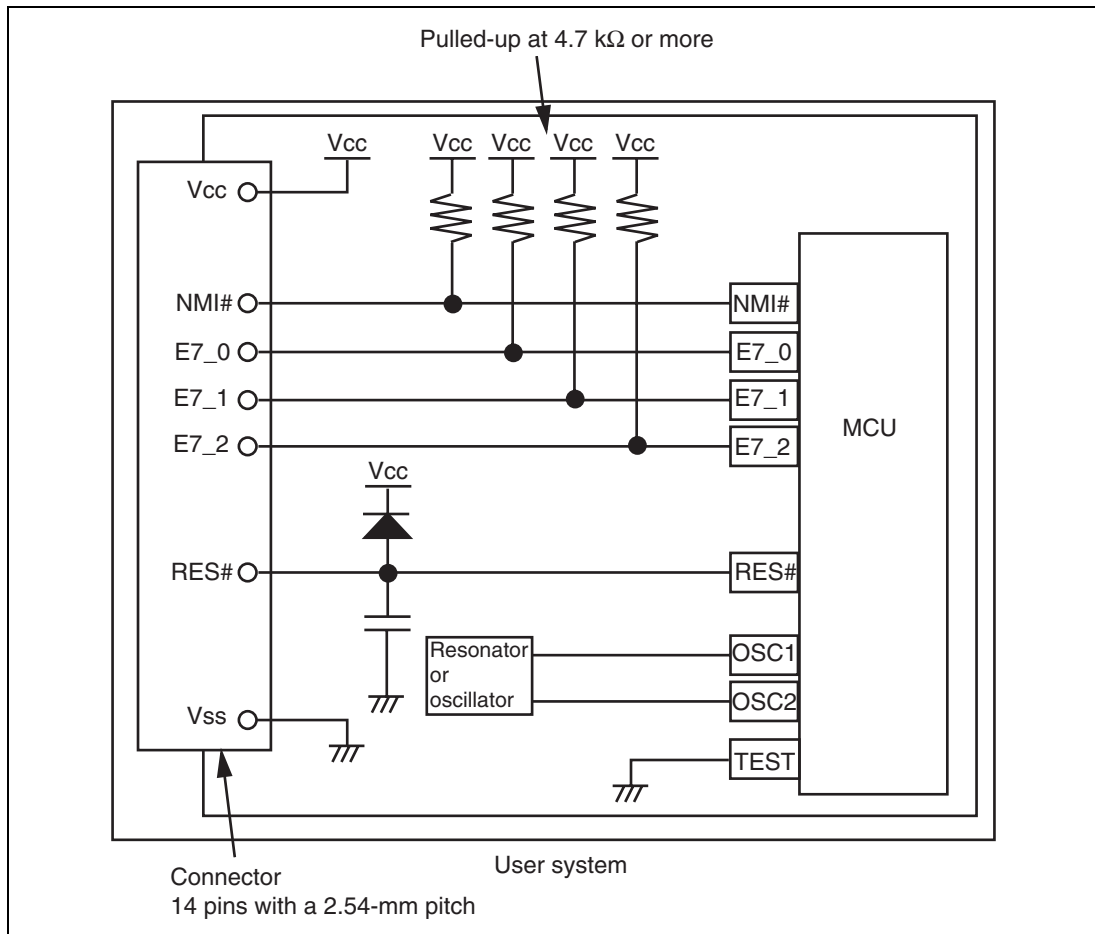

Figure 4.1 Example of Emulator Connection

Notes: 1. E7_0 to E7_2 pins are used by the emulator. Pull up and connect the emulator and MCU pins.

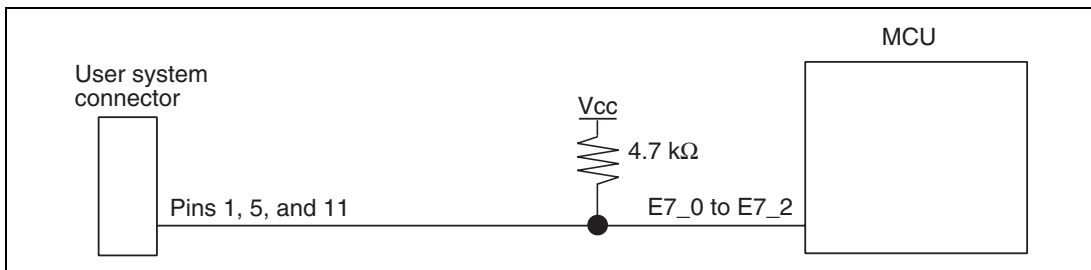

Figure 4.2 Connection of Emulator and E7_0 to E7_2 Pins

2. The NMI# signal is used for forced break control by the emulator. Connect the emulator and MCU pins directly. In debugging without forced break control, change the mode with the High-performance Embedded Workshop. Then, when the user logic is connected with the open-collector output buffer, the NMI# pin can be used in the user system (however, at power-on, the NMI# pin is used by the emulator).

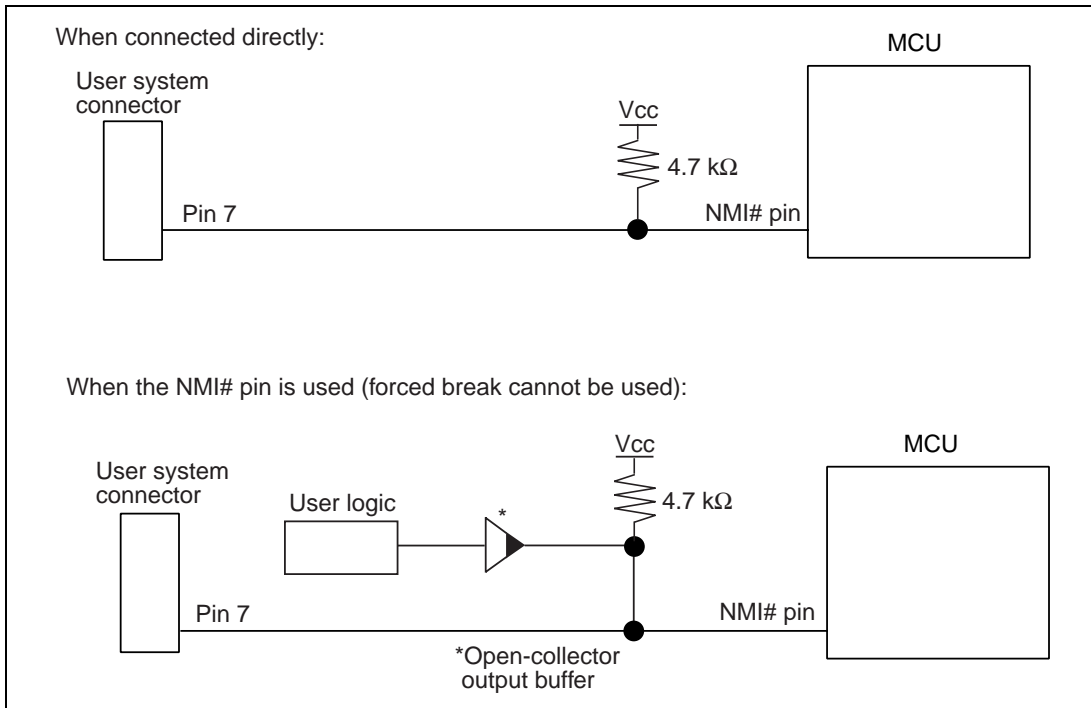

Figure 4.3 Connection of Emulator and NMI# Pin

- The RES# pin is used by the emulator. Create the following circuit so that reset input can be accepted from the emulator.

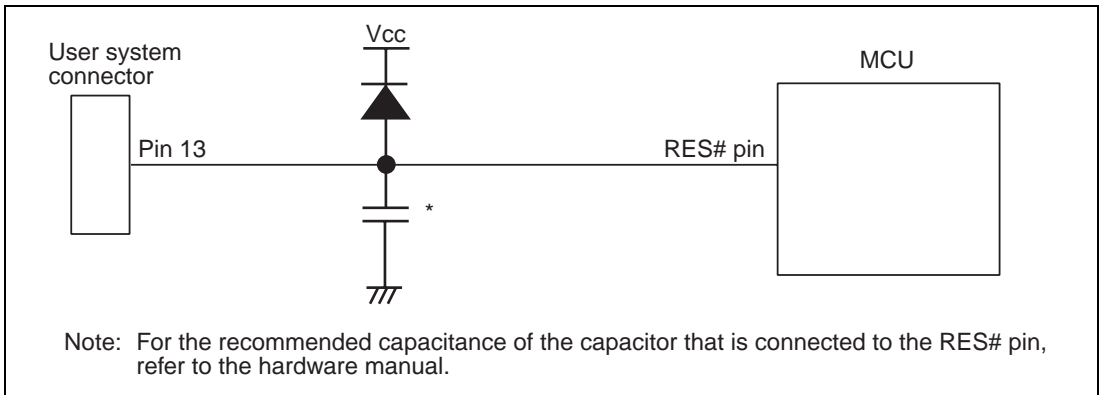

Figure 4.4 Example of a Reset Circuit

- Connect Vss and Vcc with the Vss and Vcc of the MCU, respectively (within the guaranteed range of the microcomputer).
When the power-supply mode is used, the power is supplied to the user system. Check that the power consumption or voltage of the user system is within the available range of E8a and avoid a problem such as closing of the power-supply circuit.
- Connect nothing with N.C.
- Use of the internal oscillator circuit is available in the H8/38602RF or H8/38606F.
However, a resonator or an oscillator must be connected to OSC1 and OSC2 pins when the emulator is connected.
- When the emulator is connected to the user system, ground the TEST pin of the MCU.

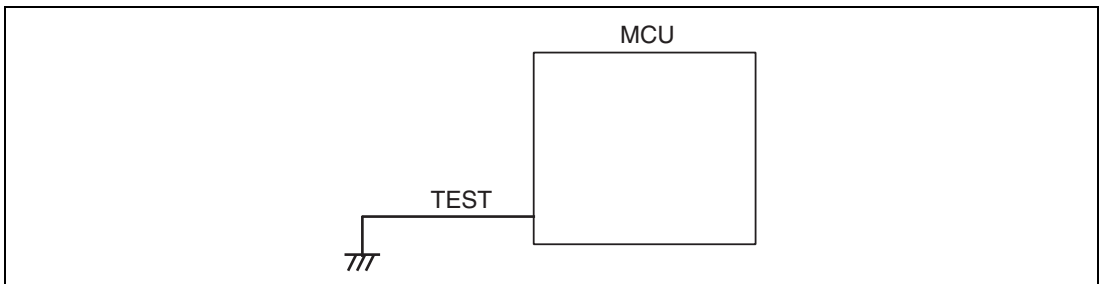

Figure 4.5 Emulator and the TEST Pin

Note: When the emulator is connected, ADTRG#, which is also used as the TEST pin, cannot be used.



WARNING

In the power-supply mode, connect the emulator after checking that the power-supply circuit on the user system is not closed or the pin number assignments of the user system connector is correct.

Failure to do so will result in a FIRE HAZARD and will damage the host computer, the emulator, and the user system.

8. When the MCU in use is connected to the emulator, the pin functions listed below are not available.

Table 4.1 Pin Functions Not Available

H8/38602RF and H8/38606F

NMI# (normal)

ADTRG#

9. Figure 4.6 shows the interface circuit in the E8a emulator. Use this figure as a reference when determining the pull-up resistance value.

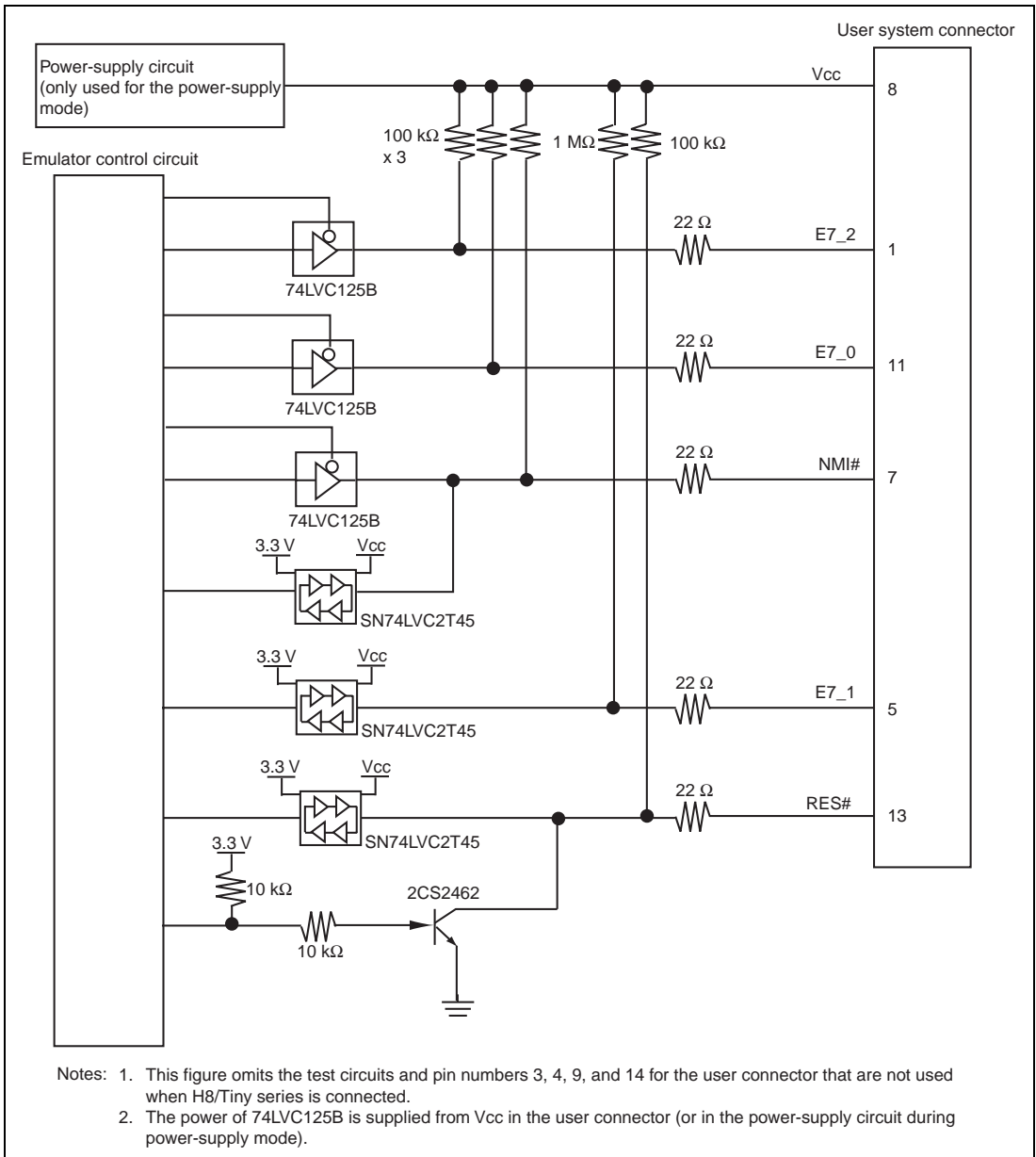

Figure 4.6 Interface Circuit in the E8a Emulator (Reference)

Section 5 Differences between the MCUs (H8/38602RF and H8/38606F) and the Emulator

This section describes the differences between the emulator and MCU operations.

1. [Emulator Setting] Dialog Box

The [Emulator Setting] dialog box is provided for setting the items that need to be set when the emulator starts up (settings are saved in the session).

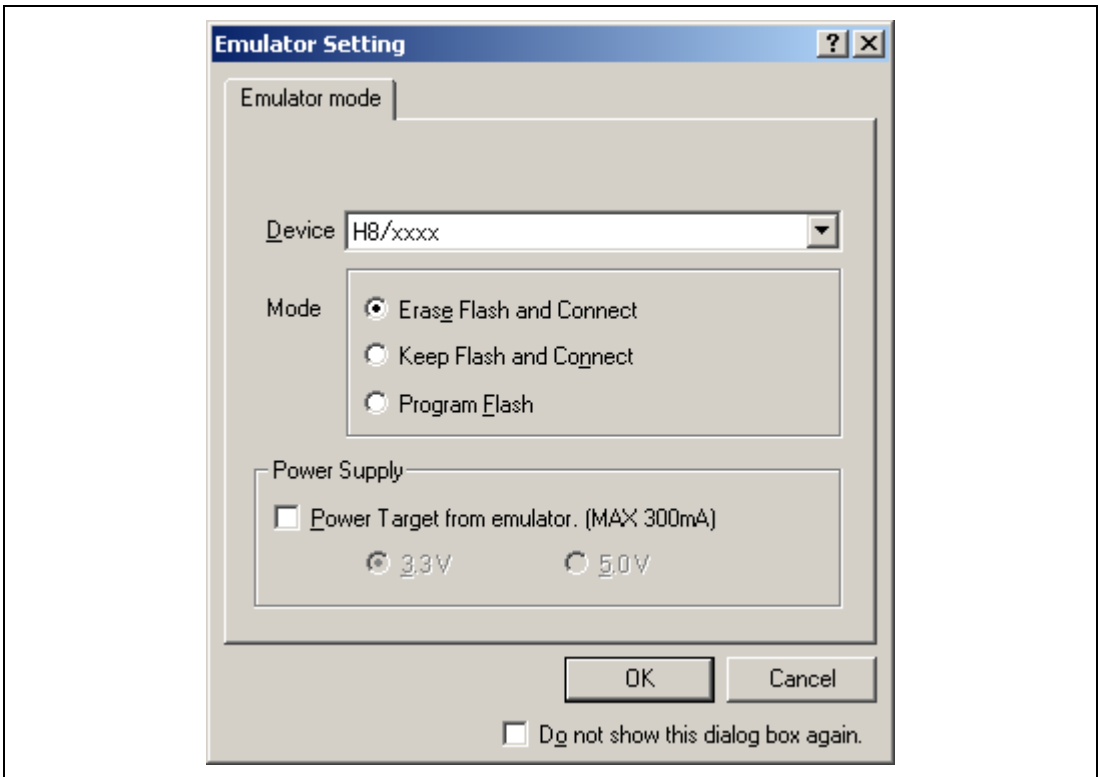

Figure 5.1 [Emulator Setting] Dialog Box

To keep the [Emulator Setting] dialog box closed next time the emulator is started, check "Do not show this dialog box again." at the bottom of the [Emulator Setting] dialog box. You can open the [Emulator Setting] dialog box using either one of the following methods:

- After the emulator gets started, select Menu - [Setup] -> [Emulator] -> [Emulator Setting...].
- Start the emulator while holding down the Ctrl key.
- After the emulator gets started and an error occurred, restart the emulator.

When you check "Do not show this dialog box again.", the emulator doesn't supply power to the user system. To use this check box, start the emulator after turning on the power.

2. Emulator Mode

The selection of the device, the specification of the mode, and the setting of the power supply are done in the [Emulator mode] page of the [Emulator Setting] dialog box.

— Device

Select the device name in use from the [Device] combo box. The following items are selected in the [Mode] group box.

— Modes

- Erase Flash and Connect

This mode is used when there is no emulator program in the flash memory of the target device. In this mode, data of the flash memory of the target device is erased when the emulator is activated. Select this item when the emulator is firstly activated, the version of the emulator's software is updated, or the ID code is changed.

- Keep Flash and Connect

This mode is used when there is an emulator program in the flash memory of the target device. Enter the ID code specified above ('Erase Flash and Connect'). If an incorrect code is entered, all the programs on the flash memory will be erased.

Note: When the emulator gets started in this mode after selecting "Do not show this dialog box again.", the initial values of the ID code is '0E8a' for the E8a emulator. If you use the ID code other than the initial value, do not use "Do not show this dialog box again."

- Program Flash

This mode is used when the emulator is used for programming the flash memory. Debugging the program is disabled. To download the load module, register it in the workspace.

Note: In the H8/Tiny or H8/Super Low Power device, the ID code is not entered in the Program Flash mode.

- Power Supply

When [Power Target from emulator. (MAX 300mA)] is checked, power will be supplied to the user system up to 300 mA. Then select 3.3 V or 5.0 V according to the power voltage of the user system.

3. Emulator Activation and ID Code

In the H8/Tiny- or H8/Super Low Power-series MCU, the [System Clock] and [ID Code] dialog boxes are set when the emulator is activated.

- Setting the system clock

Enter the clock value input to the board in use. The initial value differs in each MCU.

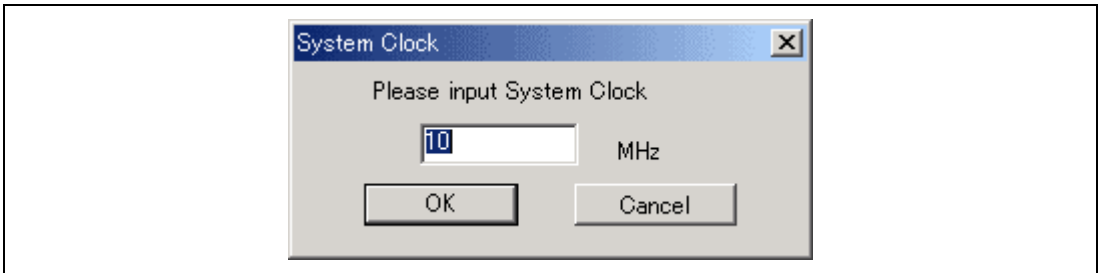

Figure 5.2 [System Clock] Dialog Box

- Setting the ID code

When the emulator is activated in the [Erase Flash and Connect] mode, enter any hexadecimal four-digit ID code to be set (except for H'FFFF). The initial value is H'0E8A. When the emulator is activated in the [Keep Flash and Connect] mode, enter the correct ID code. If an incorrect ID code is entered, all the contents of the flash memory will be erased. In this case, restart the emulator in the [Erase Flash and Connect] mode.

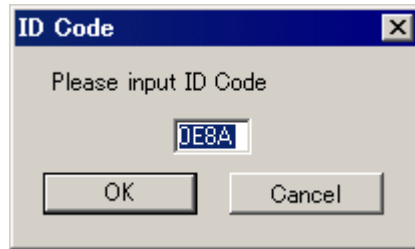

Figure 5.3 [ID Code] Dialog Box

4. When the emulator system is initiated, it initializes the general registers and part of the control registers as shown in table 5.1.

Table 5.1 Register Initial Values at Emulator Power-On

Register	Initial Value
PC	Reset vector value in the vector address table
ER0 to ER6	H'0000
ER7 (SP)	H'FF80
CCR	H'80

5. Low-Power Mode

During a user program break, the CPU operating frequency is forced to a system clock (ϕ) for high-speed operation.

6. RES# Signal

The RES# signal is only valid during user program execution started with clicking the GO or STEP-type button. During a user program break, the RES# signal is not sent to the MCU.

Note: Do not start user program execution or access the memory while control input signal (RES#) is being low. A TIMEOUT error will occur.

7. System Control Register

In the emulator, the internal I/O registers can be accessed from the [IO] window. However, be careful when accessing the system control register. The emulator saves the register value of the system control register at a break and returns the value when the user program is executed. Since this is done during a break, do not rewrite the system control register in the [IO] window.

8. Memory Access during Emulation

If the memory contents are referenced or modified during emulation, realtime emulation cannot be performed because the user program is temporarily halted.

9. The emulator communicates with the MCUs by using the NMI#, RES#, and E7_2 to E7_0 pins. These pins cannot be used, however, the NMI# pin can be used by changing the setting of the [NMI signal] group box in the [Configuration] dialog box.

10. Sum Data Displayed in the Program Flash Mode

Sum data, which is displayed in the 'Program Flash' mode, is a value that data in the whole ROM areas has been added by byte (including data in the dedicated ROM area for the emulator).

11. Note on Executing the User Program

The set value is rewritten since the emulator uses flash memory and watchdog timer registers during programming (Go, Step In, Step Out, or Step Over) of the flash memory.

12. The power consumed by the MCU can reach several milliamperes. This is because the user power supply drives ICs to make the communication signal level match the user-system power-supply voltage. The power consumed rises little during user program execution since the emulator does not perform communication; it rises more during a break.

13. Program Area for the Emulator

Do not access a part of areas in the flash memory or the internal RAM since the emulator program uses these areas. If the contents of the program area for the emulator are changed, the emulator will not operate normally. In this case, restart the emulator with the Erase Flash and Connect mode.

Table 5.2 Program Area for the E8a Emulator

MCU Name	Program Area
H8/38602RF	Emulator ROM: H'4000 to H'4FFF Internal RAM: H'F780 to H'FB7F Vector, etc.: H'0002 to H'000F, H'4FF8 to H'4FF9
H8/38606F	Emulator ROM: H'C000 to H'CFFF Internal RAM: H'F380 to H'F77F Vector, etc.: H'0002 to H'000F, H'CFF8 to H'CFF9

14. The emulator uses a two-word stack pointer for values stored on a user program break. Therefore, the stack area must accept two-word addresses.

15. Do not use an MCU that has been used for debugging.

If the flash memory is rewritten many times, data may be lost due to retention problems after the emulator has been left for a few days and the data will be erased. If an error message is displayed, exchange the MCU for a new one.

16. Forced Break Function

When the NMI# signal is used for a forced break in the emulator, the vector address of NMI# is rewritten by the emulator program. An error will occur if a file in the host computer and the flash memory contents are verified. Do not use the flash memory contents as the ROM data for the mask ROM after it has been saved.

17. Setting the Usage of the NMI# Signal

In the [Configuration] dialog box, when the NMI# signal is changed as it is used in the user program, the vector address of NMI# is not recovered. Reload the user program.

18. Address Break Release Function

When the address break function is not released for users, the vector address of address break is rewritten by the emulator program. An error will occur if a file in the host computer and the flash memory contents are verified. Do not use the flash memory contents as the ROM data for the mask ROM after it has been saved.

19. Initializing the Internal I/O Register with the Reset_CPU Function

Be sure to initialize the internal I/O registers shown below by the user program since they are not initialized by selecting [Debug] – [Reset CPU] or using the RESET command.

Table 5.3 Registers Not Initialized

MCU Name	Register Not Initialized
H8/38602RF	SYSCR1, SYSCR2, IEGR1, IENR1, IENR2, OSCCR, IRR1, IRR2, IWPR,
H8/38606F	CKSTPR1, CKSTPR2

20. Step Execution of the SLEEP Instruction

When the interrupt mask bit (I) in the condition code register (CCR) is 1, do not perform step execution of the SLEEP instruction. If the step execution is performed and not finished correctly, restart the emulator.

21. Use of the internal oscillator circuit is available in the H8/38602RF or H8/38606F. However, a resonator or an oscillator must be connected to OSC1 and OSC2 pins when the emulator is connected.

22. Processing When Booting up the Emulator

When the emulator is booted up, the watchdog timer (WDT) is not active, so the operation of the emulator differs in this way from that of an MCU when the emulator is not in use. When the MCU is initialized by a reset or in some other way after the emulator is booted up, the WDT becomes active. If you intend to use the WDT, set the WDT up as required from the initializing routine, while if you do not intend to use the WDT, stop activation of the WDT from the initializing routine.

23. Hardware Break Functions

- In the H8/38602RF, H8/38606F E8a emulator, conditions of Break Condition 1,2 can be set. Table 5.4 lists the items that can be specified.

Table 5.4 Hardware Break Condition Specification Items

Items	Description
Address bus condition	Breaks when the MCU address bus value matches the specified value.
Data bus condition	Breaks when the MCU data bus value matches the specified value. High or low byte or word can be specified as the access data size.
Read or write condition	Breaks in the read or write cycle.

Table 5.5 lists the combinations of conditions that can be set in the [Break condition] dialog box.

Table 5.5 Conditions Set in [Break condition] Dialog Box

Dialog Box	Condition		
	Address Bus Condition	Data Condition	Read or Write Condition
[Break condition 1]	○	○	○
[Break condition 2]	○	X	X

Note: ○: Can be set by checking the radio button in the dialog box.

Table 5.6 lists the combinations of conditions that can be set by the BREAKCONDITION_SET command.

Table 5.6 Conditions Set by BREAKCONDITION_SET Command

Channel	Condition		
	Address Bus Condition (<addropt> option)	Data Condition (<dataopt> option)	Read or Write Condition (<r/wopt> option)
Break condition 1	○	○	○
Break condition 2	○	X	X

Note: ○: Can be set by the BREAKCONDITION_SET command.

- Notes on Setting the Break Condition
 1. When [Step In], [Step Over], or [Step Out] is selected, the settings of Break Condition are disabled.
 2. The settings of Break Condition are disabled when an instruction to which a BREAKPOINT has been set is executed.
 3. When step over function is used, the settings of BREAKPOINT and Break Condition are disabled.
 4. Do not satisfy Break Condition 2 and another break source (BREAKPOINT or Break Condition 1) simultaneously. A break will occur with an illegal value.

24. Items Set in the [Configuration] Dialog Box

The emulator operation conditions are set in the [Configuration] dialog box.

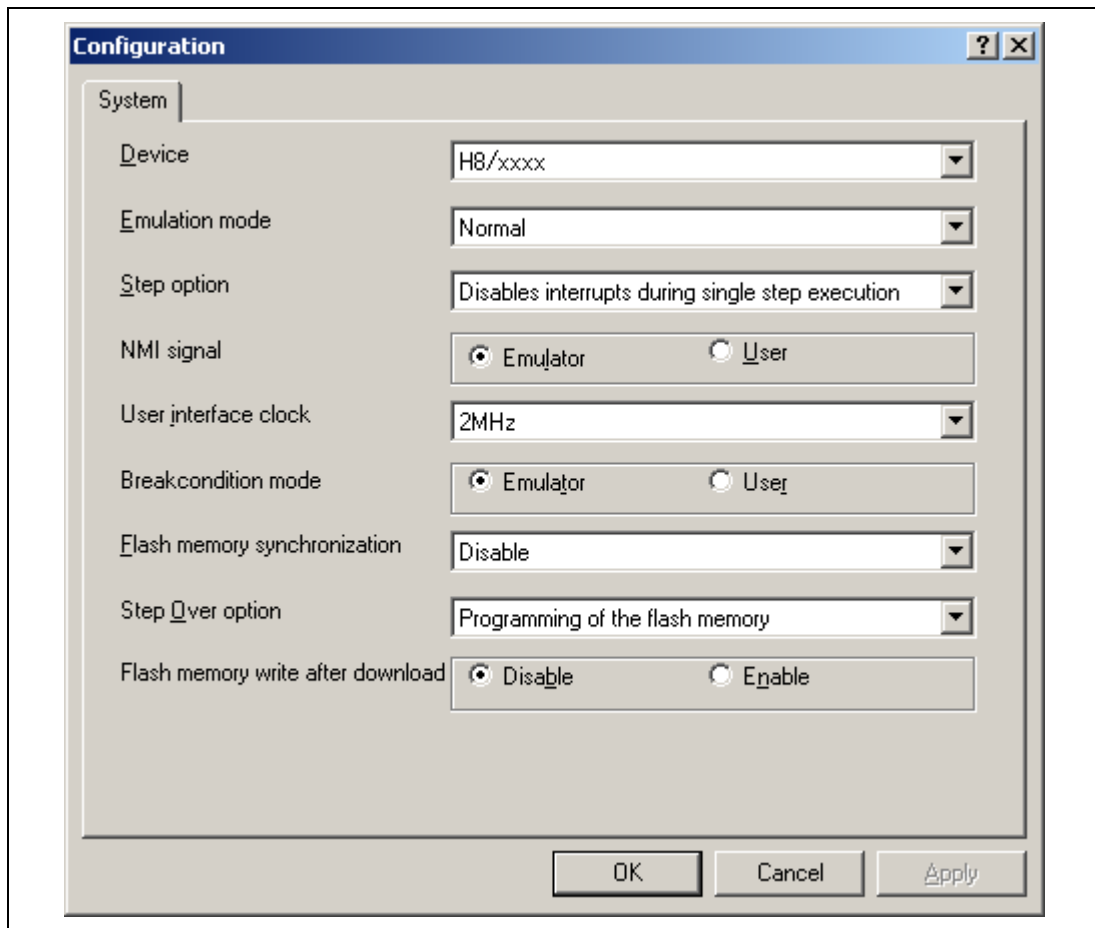

Figure 5.4 [Configuration] Dialog Box ([System] Page)

Items that can be displayed in this dialog box are listed below.

[Device] combo box	Displays the MCU name.
[Emulation mode] combo box	Selects the emulation mode at user program execution. Select Normal to perform normal emulation. Select No break to disable PC breakpoint or break condition settings during emulation.
[Step option] combo box	Sets the step interrupt option. Disable interrupts during single step execution: Disables interrupts ¹ during step execution. Enable interrupts during single step execution: Enables interrupts ¹ during step execution.
[NMI signal] group box	Sets the use of the NMI# signal. When used as a forced break in the emulator, select Emulator. In this case, the NMI# signal cannot be used. The contents of the NMI# vector address are rewritten by the emulator program. When used in the user program, select User. In this case, the forced break cannot be used. Before user program execution, set the breakpoints or break conditions for the exception processing and generate exceptions to halt the program.
[User interface clock] combo box	Displays the transfer clock of the user interface.
[Breakcondition mode] group box	Sets the address break release function. When the address break function is not used in the user program, select Emulator. In this case, the hardware break and step functions can be used. The contents of the vector address are rewritten by the emulator program to satisfy the break conditions. When the address break is used in the user program, select User. In this case, the hardware break function (Break Condition 2) cannot be used.
[Flash memory synchronization] combo box	Selects whether or not the contents of the flash memory are acquired by the emulator when the user program is stopped or the position where the PC break is set is put back as the original code. When the flash memory is not programmed by the user program, its contents need not be acquired by the emulator.

If there is no problem with the state that the program in the flash memory has been replaced as the PC break code, the position where the PC break is set needs not be put back as the original code.

Disable: Read or program is not performed for the flash memory except when the emulator is activated, the flash memory area is modified, and the settings of the PC break to the flash memory area are changed.

PC to flash memory: When the user program is stopped, the specified PC break code is replaced as the original instruction. Select this option if there is a problem with the state that the program in the flash memory has been replaced as the PC break code.

Flash memory to PC: When the user program is stopped, the contents of the flash memory are read by the emulator. Select this option if the flash memory is reprogrammed by the user program.

PC to flash memory, Flash memory to PC:

When the user program is stopped, the contents of the flash memory are read by the emulator and the specified PC break code is replaced as the original instruction. Select this option if the flash memory is reprogrammed by the user program and there is a problem with the state that the program in the flash memory has been replaced as the PC break code.

[Step Over option] combo box

Enables or disables programming of the flash memory while executing step operation.

Programming of the flash memory: Uses a software break for step operation (e.g. Step Over) and enables programming of the flash memory.

No Programming of the flash memory: Uses Break Condition for step operation (e.g. Step Over) and disables programming of the flash memory².

[Flash memory write after download] group box

Enables or disables programming of the flash memory after downloading the program.

Disable: Disables programming of the flash memory after downloading the program.

Enable: Enables programming of the flash memory after downloading the program.

- Notes:
1. Includes interrupts in a break.
 2. When Step Over is performed after selecting [No Programming of the flash memory] for [Step Over option], the instruction that follows a JSR, BSR, or TRAPA instruction will also be executed. If there are consecutive JSR, BSR, or TRAPA instructions, execution proceeds until it reaches an instruction that is not JSR, BSR, or TRAPA. (When there are consecutive function calls in C language, the program steps all of these functions.)

Notes on Connecting the H8/38099F and H8/38799F

Section 1 Inside the E8a Emulator User's Manual

The E8a emulator (hereafter referred to as E8a emulator in this document) manual consists of two documents: the E8a User's Manual and the E8a Additional Document for User's Manual (this document). Be sure to read BOTH documents before using the E8a emulator.

(1) E8a Emulator User's Manual

The E8a Emulator User's Manual describes the hardware specifications and how to use the emulator debugger.

- E8a emulator hardware specifications
- Connecting the E8a emulator to the host computer or user system
- Operating the E8a emulator debugger
- Tutorial: From starting up the E8a emulator debugger to debugging

(2) E8a Additional Document for User's Manual

The E8a Additional Document for User's Manual describes content dependent on the MCUs and precautionary notes.

- Example of the E8a emulator connection or interface circuit necessary for designing the hardware
- Notes on using the E8a emulator
- Setting the E8a emulator debugger during startup

Section 2 Connecting the Emulator with the User System

Before connecting an E8a emulator (hereafter referred to as emulator) with the user system, a connector must be installed in the user system so that a user system interface cable can be connected. When designing the user system, refer to the connector and recommended circuits shown in this manual.

Before designing the user system, be sure to read the E8a emulator user's manual and the hardware manual for related MCUs.

Table 2.1 shows the recommended connector for the emulator.

Table 2.1 Recommended Connector

Type Number	Manufacturer	Specifications
2514-6002	3M Limited	14-pin straight type

Connect pins 2, 4, 6, 10, 12, and 14 of the user system connector to GND firmly on the PCB. These pins are used as electrical GND and to monitor the connection of the user system connector. Note the pin assignments of the user system connector.

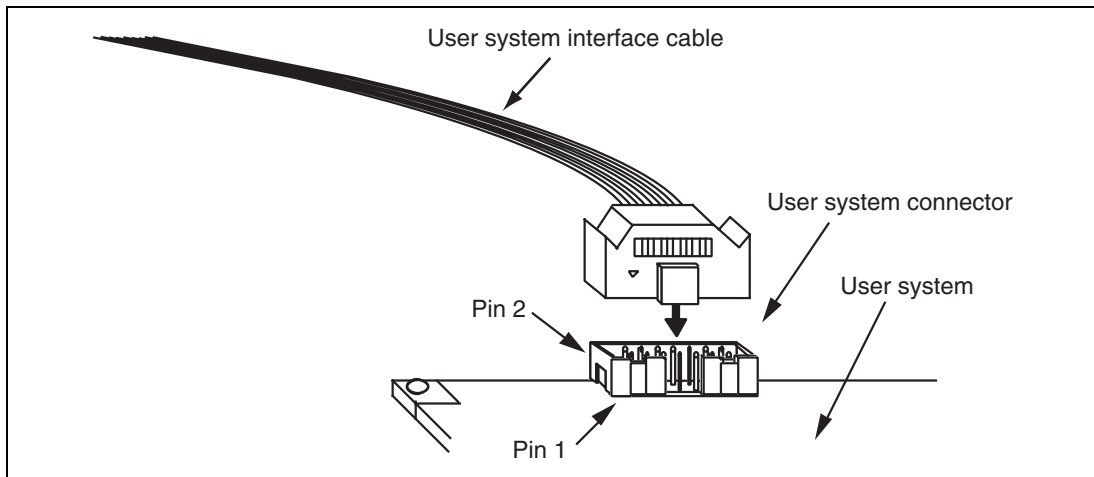

Figure 2.1 Connecting the User System Interface Cable to the User System

- Notes:
1. The pin number assignments of the 14-pin connector differ from those of the E10A-USB emulator; however, the physical location is the same.
 2. Do not place any components within 3 mm of the connector.
- When the emulator is used in the [Program Flash] mode, connect the emulator similarly to the user system.

Section 3 Pin Assignments of the E8a Connector

Figure 3.1 shows the pin assignments of the emulator's connector.

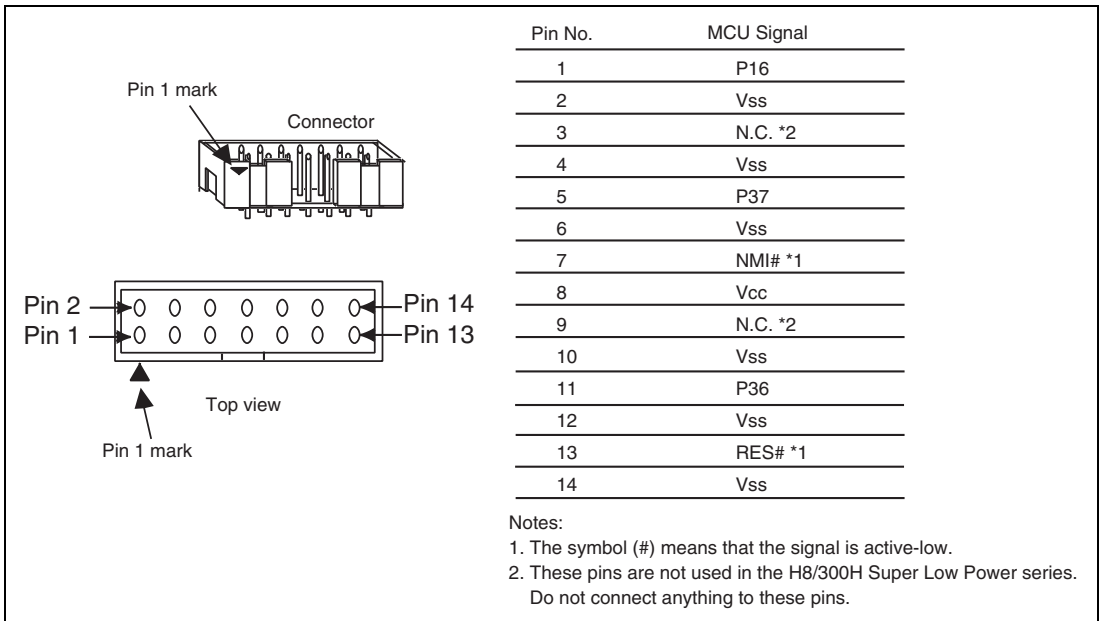

Figure 3.1 Pin Assignments of the Emulator's Connector

Section 4 Example of Emulator Connection

Figure 4.1 shows an example of emulator connection to the MCU.

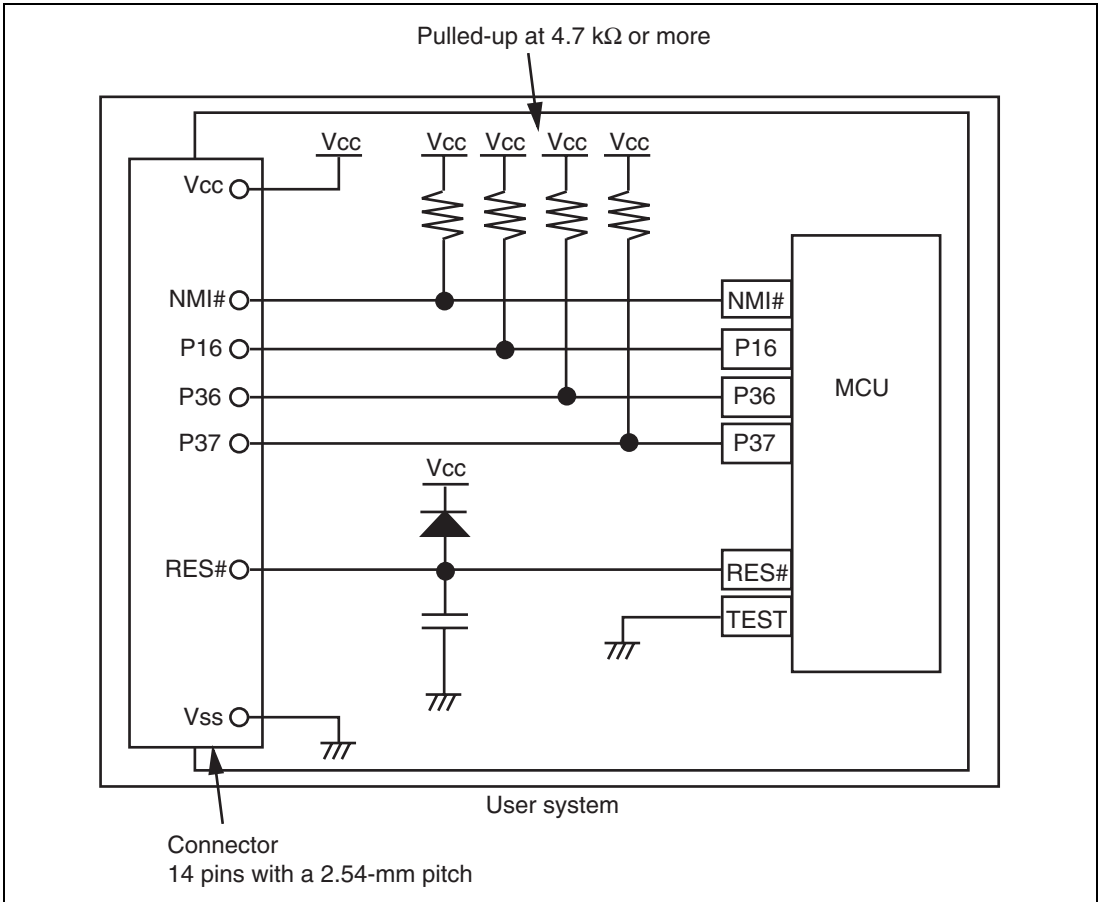

Figure 4.1 Example of Emulator Connection

Notes: 1. P16, P36, and P37 pins are used by the emulator. Pull up and connect the emulator and MCU pins.

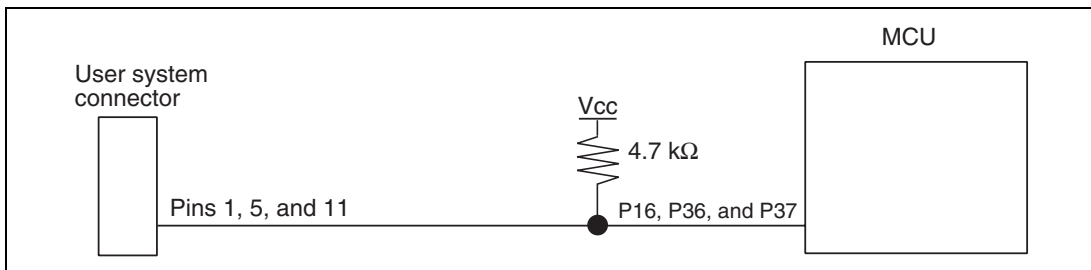

Figure 4.2 Connection of Emulator and P16, P36, and P37 Pins

2. The NMI# signal is used for forced break control by the emulator. Connect the emulator and MCU pins directly. In debugging without forced break control, change the mode with the High-performance Embedded Workshop. Then, when the user logic is connected with the open-collector output buffer, the NMI# pin can be used in the user system (however, at power-on, the NMI# pin is used by the emulator).

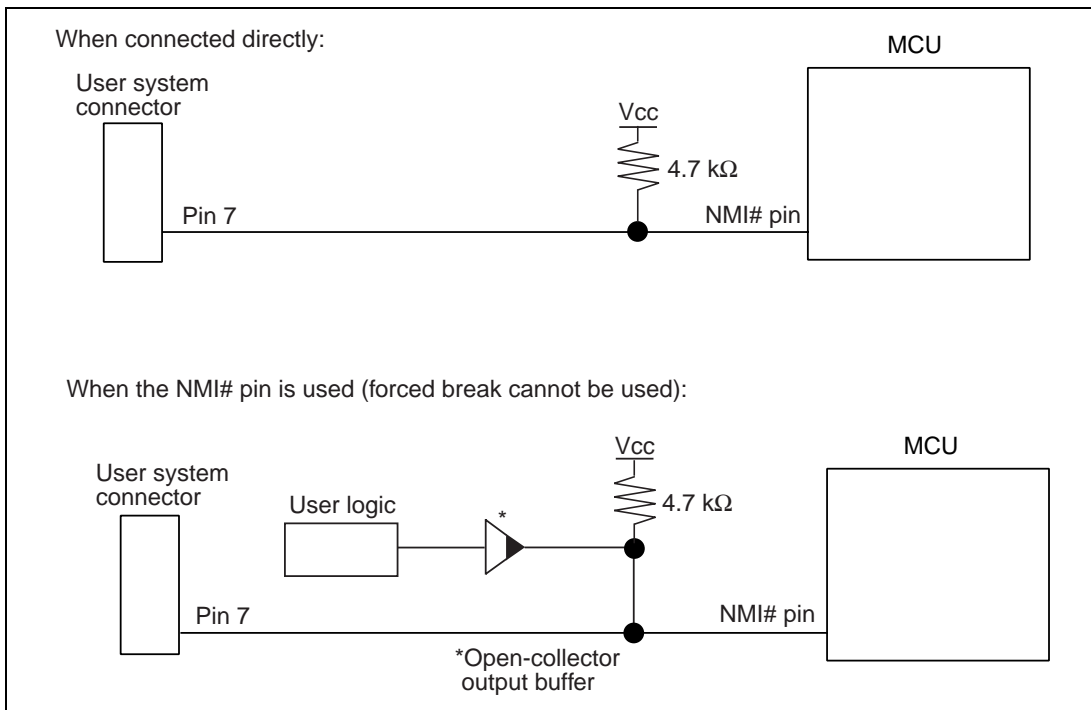

Figure 4.3 Connection of Emulator and NMI# Pin

- The RES# pin is used by the emulator. Create the following circuit so that reset input can be accepted from the emulator.

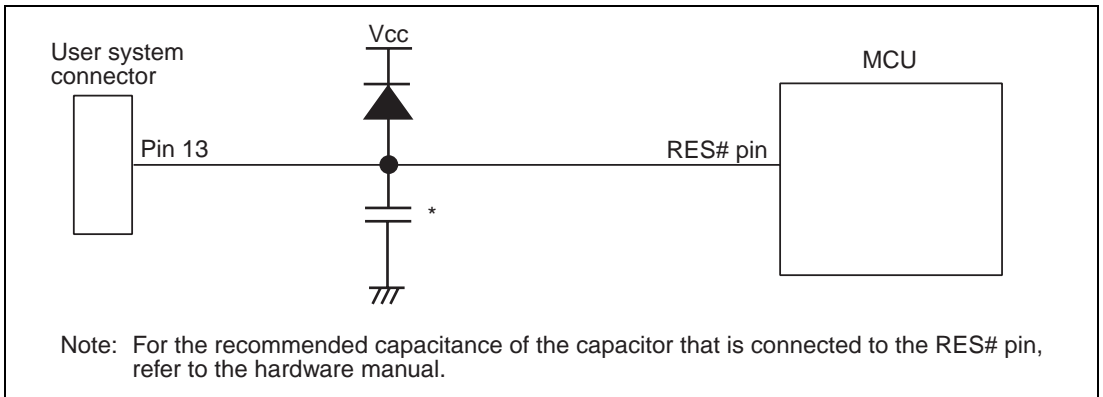

Figure 4.4 Example of a Reset Circuit

- Connect Vss and Vcc with the Vss and Vcc of the MCU, respectively (within the guaranteed range of the microcomputer).
When the power-supply mode is used, the power is supplied to the user system. Check that the power consumption or voltage of the user system is within the available range of E8a and avoid a problem such as closing of the power-supply circuit.
- Connect nothing with N.C.
- When the emulator is connected to the user system, ground the TEST pin of the MCU.

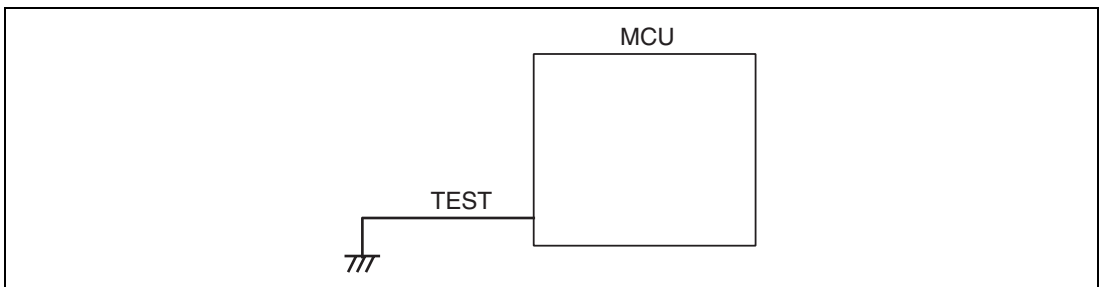

Figure 4.5 Emulator and the TEST Pin

Note: When the emulator is connected, ADTRG#, which is also used as the TEST pin, cannot be used.



WARNING

In the power-supply mode, connect the emulator after checking that the power-supply circuit on the user system is not closed or the pin number assignments of the user system connector is correct.

Failure to do so will result in a FIRE HAZARD and will damage the host computer, the emulator, and the user system.

- When the MCU in use is connected to the emulator, the pin functions listed below are not available.

Table 4.1 Pin Functions Not Available

H8/38099F and H8/38799F

P16, P36, and P37

NMI# (normal)

ADTRG#

- Figure 4.6 shows the interface circuit in the E8a emulator. Use this figure as a reference when determining the pull-up resistance value.

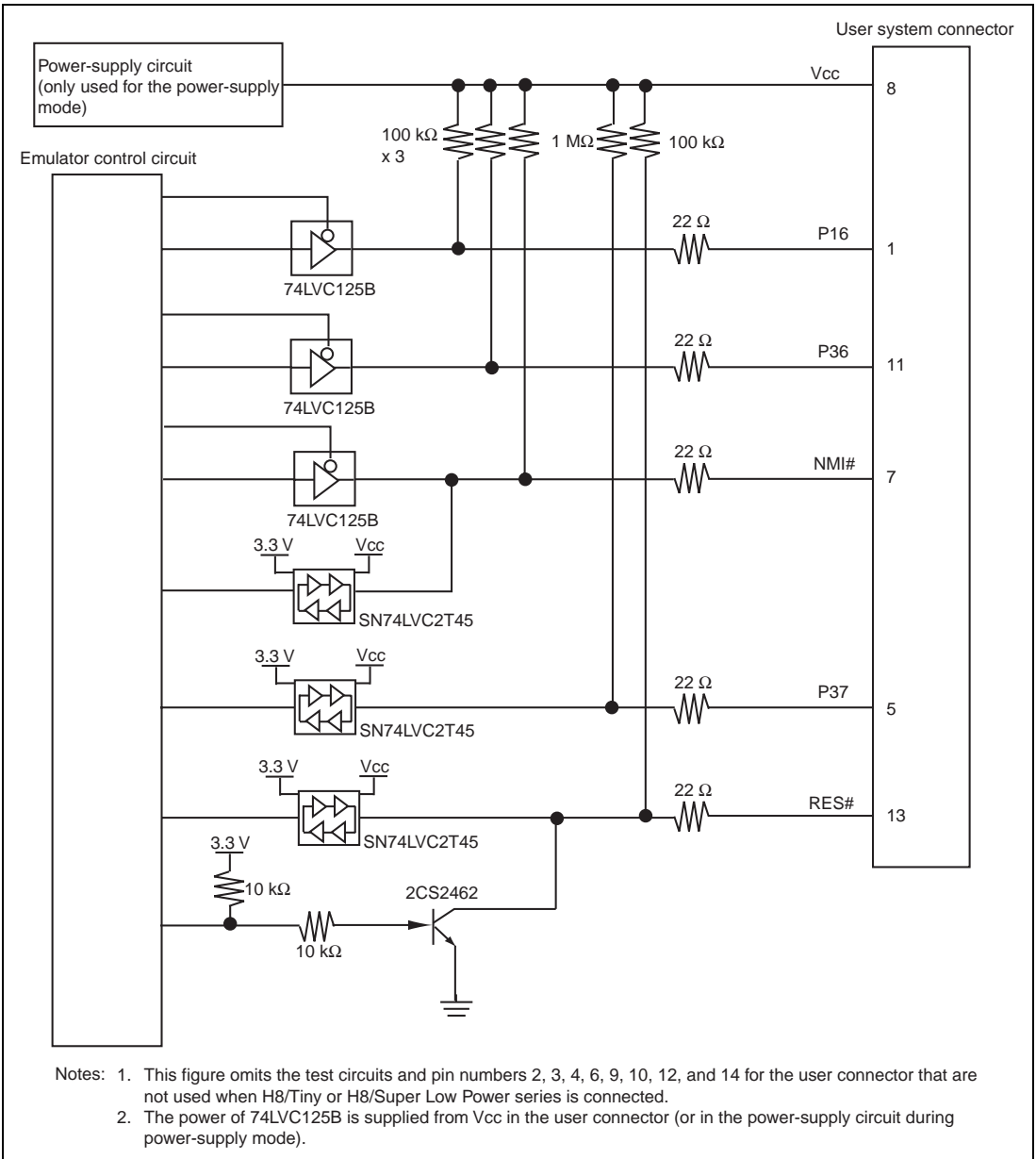

- Notes:
1. This figure omits the test circuits and pin numbers 2, 3, 4, 6, 9, 10, 12, and 14 for the user connector that are not used when H8/Tiny or H8/Super Low Power series is connected.
 2. The power of 74LVC125B is supplied from Vcc in the user connector (or in the power-supply circuit during power-supply mode).

Figure 4.6 Interface Circuit in the E8a Emulator (Reference)

Section 5 Differences between the MCUs (H8/38099F and H8/38799F) and the Emulator

This section describes the differences between the emulator and MCU operations.

1. [Emulator Setting] Dialog Box

The [Emulator Setting] dialog box is provided for setting the items that need to be set when the emulator starts up (settings are saved in the session).

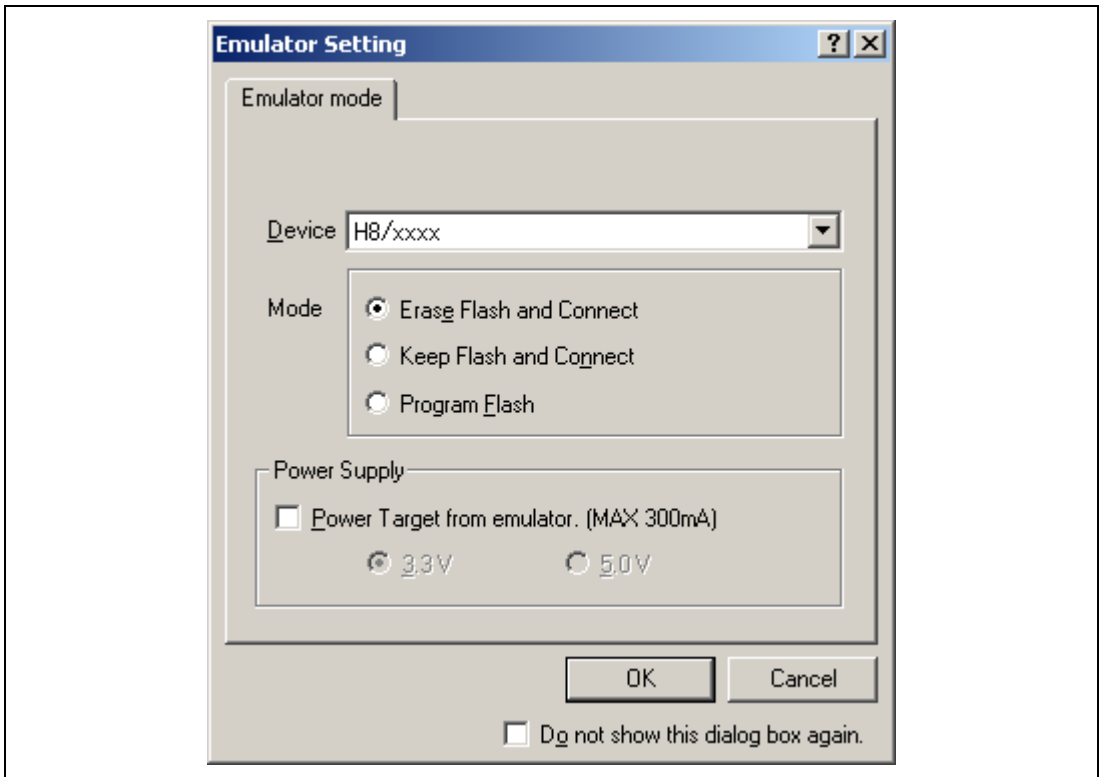

Figure 5.1 [Emulator Setting] Dialog Box

To keep the [Emulator Setting] dialog box closed next time the emulator is started, check "Do not show this dialog box again." at the bottom of the [Emulator Setting] dialog box. You can open the [Emulator Setting] dialog box using either one of the following methods:

- After the emulator gets started, select Menu - [Setup] -> [Emulator] -> [Emulator Setting...].
- Start the emulator while holding down the Ctrl key.
- After the emulator gets started and an error occurred, restart the emulator.

When you check "Do not show this dialog box again.", the emulator doesn't supply power to the user system. To use this check box, start the emulator after turning on the power.

2. Emulator Mode

The selection of the device, the specification of the mode, and the setting of the power supply are done in the [Emulator mode] page of the [Emulator Setting] dialog box.

— Device

Select the device name in use from the [Device] combo box. The following items are selected in the [Mode] group box.

— Modes

- Erase Flash and Connect

This mode is used when there is no emulator program in the flash memory of the target device. In this mode, data of the flash memory of the target device is erased when the emulator is activated. Select this item when the emulator is firstly activated, the version of the emulator's software is updated, or the ID code is changed.

- Keep Flash and Connect

This mode is used when there is an emulator program in the flash memory of the target device. Enter the ID code specified above ('Erase Flash and Connect'). If an incorrect code is entered, all the programs on the flash memory will be erased.

Note: When the emulator gets started in this mode after selecting "Do not show this dialog box again.", the initial value of the ID code is '0E8a'. If you use the ID code other than the initial value, do not use "Do not show this dialog box again."

- Program Flash

This mode is used when the emulator is used for programming the flash memory. Debugging the program is disabled. To download the load module, register it in the workspace.

Note: In the H8/Tiny or H8/Super Low Power device, the ID code is not entered in the Program Flash mode.

- Power Supply

When [Power Target from emulator. (MAX 300mA)] is checked, power will be supplied to the user system up to 300 mA. Then select 3.3 V or 5.0 V according to the power voltage of the user system.

3. Emulator Activation and ID Code

In the H8/Tiny- or H8/Super Low Power-series MCU, the [System Clock] and [ID Code] dialog boxes are set when the emulator is activated.

- Setting the system clock

Enter the clock value input to the board in use. The initial value differs in each MCU.

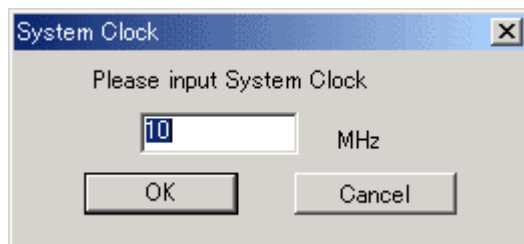

Figure 5.2 [System Clock] Dialog Box

- Setting the ID code

When the emulator is activated in the [Erase Flash and Connect] mode, enter any hexadecimal four-digit ID code to be set (except for H'FFFF). The initial value is H'0E8A. When the emulator is activated in the [Keep Flash and Connect] mode, enter the correct ID code. If an incorrect ID code is entered, all the contents of the flash memory will be erased. In this case, restart the emulator in the [Erase Flash and Connect] mode.

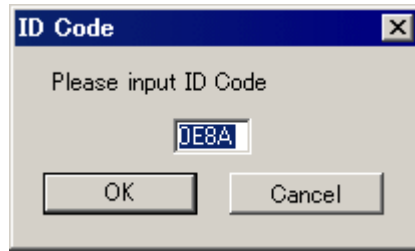

Figure 5.3 [ID Code] Dialog Box

4. When the emulator system is initiated, it initializes the general registers and part of the control registers as shown in table 5.1.

Table 5.1 Register Initial Values at Emulator Power-On

Register	Initial Value
PC	Reset vector value in the vector address table
ER0 to ER6	H'000000
ER7	H'FFFF80
CCR	H'80

5. Low-Power Mode

During a user program break, the CPU operating frequency is forced to a system clock (ϕ) for high-speed operation.

6. RES# Signal

The RES# signal is only valid during user program execution started with clicking the GO or STEP-type button. During a user program break, the RES# signal is not sent to the MCUs.

Note: Do not start user program execution or access the memory while control input signal (RES#) is being low. A TIMEOUT error will occur.

7. System Control Register

In the emulator, the internal I/O registers can be accessed from the [IO] window. However, be careful when accessing the system control register. The emulator saves the register value of the system control register at a break and returns the value when the user program is executed. Since this is done during a break, do not rewrite the system control register in the [IO] window.

8. Memory Access during Emulation

If the memory contents are referenced or modified during emulation, realtime emulation cannot be performed because the user program is temporarily halted.

9. The emulator communicates with the MCUs by using the NMI#, RES#, P16, P36, and P37 pins. These pins cannot be used, however, the NMI# pin can be used by changing the setting of the [NMI signal] group box in the [Configuration] dialog box.

10. Sum Data Displayed in the Program Flash Mode

Sum data, which is displayed in the 'Program Flash' mode, is a value that data in the whole ROM areas has been added by byte (including data in the dedicated ROM area for the emulator).

11. Note on Executing the User Program

The set value is rewritten since the emulator uses flash memory and watchdog timer registers during programming (Go, Step In, Step Out, or Step Over) of the flash memory.

12. The power consumed by the MCU can reach several milliamperes. This is because the user power supply drives ICs to make the communication signal level match the user-system power-supply voltage. The power consumed rises little during user program execution since the emulator does not perform communication; it rises more during a break.

13. Program Area for the Emulator

Do not access a part of areas in the flash memory or the internal RAM since the emulator program uses these areas. If the contents of the program area for the emulator are changed, the emulator will not operate normally. In this case, restart the emulator with the Erase Flash and Connect mode.

Table 5.2 Program Area for the Emulator

MCU Name	Program Area
H8/38099F	Emulator ROM: H'020000 to H'020FFF
H8/38799F	Internal RAM: H'FFA000 to H'FFA7FF Vector, etc.: H'000004 to H'000017, H'20FF8 to H'20FFF

14. The emulator uses a two-word stack pointer for values stored on a user program break. Therefore, the stack area must accept two-word addresses.
15. Do not use an MCU that has been used for debugging.
If the flash memory is rewritten many times, data may be lost due to retention problems after the emulator has been left for a few days and the data will be erased. If an error message is displayed, exchange the MCU for a new one.
16. Forced Break Function
When the NMI# signal is used for a forced break in the emulator, the vector address of NMI# is rewritten by the emulator program. An error will occur if a file in the host computer and the flash memory contents are verified. Do not use the flash memory contents as the ROM data for the mask ROM after it has been saved.
17. Setting the Usage of the NMI# Signal
In the [Configuration] dialog box, when the NMI# signal is changed as it is used in the user program, the vector address of NMI# is not recovered. Reload the user program.
18. Address Break Release Function
In the [Configuration] dialog box, when the address break is changed as it is used in the user program, Break Condition 2 is disabled in this emulator.
19. For the H8/38099F or H8/38799F, the internal resonator for the system clock is available; however, when the emulator is used, the oscillator or resonator must be connected to the OSC1 and OSC2 pins.
20. Hardware Break Functions
- In the H8/38099F or H8/38799F E8a emulator, conditions of Break Condition 1,2,3,4 can be set. Table 5.3 lists the items that can be specified.

Note: When the address break is used in the user program, Break Condition 2 is disabled.

Table 5.3 Hardware Break Condition Specification Items

Items	Description
Address bus condition	Breaks when the MCU address bus value matches the specified value.
Data bus condition	Breaks when the MCU data bus value matches the specified value. High or low byte or word can be specified as the access data size.
Read or write condition	Breaks in the read or write cycle.

Table 5.4 lists the combinations of conditions that can be set in the [Break condition] dialog box.

Table 5.4 Conditions Set in [Break condition] Dialog Box

Dialog Box	Condition		
	Address Bus Condition	Data Condition	Read or Write Condition
[Break condition 1]	○	○	○
[Break condition 2]	○	○	○
[Break condition 3]	○	X	X
[Break condition 4]	○	X	X

Note: ○: Can be set by checking the radio button in the dialog box.

Table 5.5 lists the combinations of conditions that can be set by the BREAKCONDITION_SET command.

Table 5.5 Conditions Set by BREAKCONDITION_SET Command

Channel	Condition		
	Address Bus Condition (<addropt> option)	Data Condition (<dataopt> option)	Read or Write Condition (<r/wopt> option)
Break condition 1	O	O	O
Break condition 2	O	O	O
Break condition 3	O	X	X
Break condition 4	O	X	X

Note: O: Can be set by the BREAKCONDITION_SET command.

- Notes on Setting the Break Condition

- When [Step In], [Step Over], or [Step Out] is selected, the settings of Break Condition are disabled.
- The settings of Break Condition are disabled when an instruction to which a BREAKPOINT has been set is executed.
- When step over function is used, the settings of BREAKPOINT and Break Condition are disabled.
- Do not make any setting that satisfies both Break Condition 2 and the BREAKPOINT or Break Condition 1,3,4. Otherwise, the break cause of Break Condition 2 is retained and a break will occur by executing no instruction when the user program execution is resumed.
- When Break Condition 2 is satisfied, the emulator uses the latest one branch of the branch trace information.
- Break Condition 2 causes no break when it has a conflict with a reset.

21. Items Set in the [Configuration] Dialog Box

The emulator operation conditions are set in the [Configuration] dialog box.

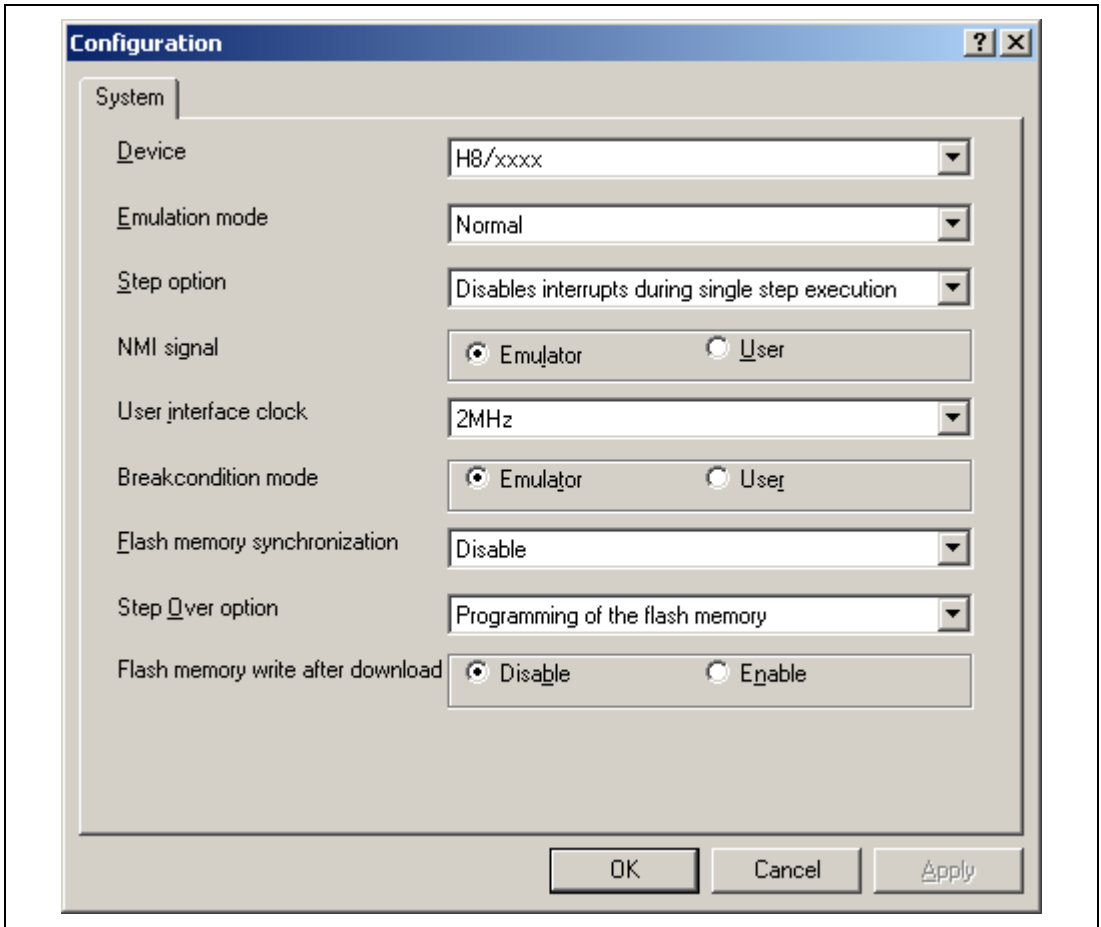

Figure 5.4 [Configuration] Dialog Box ([System] Page)

Items that can be displayed in this dialog box are listed below.

[Device] combo box	Displays the MCU name.
[Emulation mode] combo box	<p>Selects the emulation mode at user program execution.</p> <p>Select Normal to perform normal emulation.</p> <p>Select No break to disable PC breakpoint or break condition settings during emulation.</p>
[Step option] combo box	<p>Sets the step interrupt option.</p> <p>Disable interrupts during single step execution: Disables interrupts^{*1} during step execution.</p> <p>Enable interrupts during single step execution: Enables interrupts^{*1} during step execution.</p>
[NMI signal] group box	<p>Sets the use of the NMI# signal.</p> <p>When used as a forced break in the emulator, select Emulator. In this case, the NMI# signal cannot be used. The contents of the NMI# vector address are rewritten by the emulator program.</p> <p>When used in the user program, select User. In this case, the forced break cannot be used. Before user program execution, set the breakpoints or break conditions for the exception processing and generate exceptions to halt the program.</p>
[User interface clock] combo box	Displays the transfer clock of the user interface.
[Breakcondition mode] group box	<p>Sets the address break release function.</p> <p>When the address break function is not used in the user program, select Emulator. In this case, the hardware break and step functions can be used. The contents of the vector address are rewritten by the emulator program to satisfy the break conditions.</p> <p>When the address break is used in the user program, select User. In this case, the hardware break function (Break Condition 2) cannot be used.</p>
[Flash memory synchronization] combo box	<p>Selects whether or not the contents of the flash memory are acquired by the emulator when the user program is stopped or the position where the PC break is set is put back as the original code.</p> <p>When the flash memory is not programmed by the user program, its contents need not be acquired by the emulator.</p>

If there is no problem with the state that the program in the flash memory has been replaced as the PC break code, the position where the PC break is set needs not be put back as the original code.

Disable: Read or program is not performed for the flash memory except when the emulator is activated, the flash memory area is modified, and the settings of the PC break to the flash memory area are changed.

PC to flash memory: When the user program is stopped, the specified PC break code is replaced as the original instruction. Select this option if there is a problem with the state that the program in the flash memory has been replaced as the PC break code.

Flash memory to PC: When the user program is stopped, the contents of the flash memory are read by the emulator. Select this option if the flash memory is reprogrammed by the user program.

PC to flash memory, Flash memory to PC:
When the user program is stopped, the contents of the flash memory are read by the emulator and the specified PC break code is replaced as the original instruction. Select this option if the flash memory is reprogrammed by the user program and there is a problem with the state that the program in the flash memory has been replaced as the PC break code.

[Step Over option] combo box

Enables or disables programming of the flash memory while executing step operation.

Programming of the flash memory: Uses a software break for step operation (e.g. Step Over) and enables programming of the flash memory.

No Programming of the flash memory: Uses Break Condition for step operation (e.g. Step Over) and disables programming of the flash memory.

[Flash memory write after download] group box

Enables or disables programming of the flash memory after downloading the program.

Disable: Disables programming of the flash memory after downloading the program.

Enable: Enables programming of the flash memory after downloading the program.

- Notes: 1. Includes interrupts in a break.
2. When Step Over is performed after selecting [No Programming of the flash memory] for [Step Over option], the instruction that follows a JSR, BSR, or TRAPA instruction will also be executed. If there are consecutive JSR, BSR, or TRAPA instructions, execution proceeds until it reaches an instruction that is not JSR, BSR, or TRAPA. (When there are consecutive function calls in C language, the program steps all of these functions.)

22. Initializing the Internal I/O Register with the Reset_CPU Function

Be sure to initialize the internal I/O registers shown below by the user program since they are not initialized by selecting [Debug] – [Reset CPU] or using the RESET command.

Table 5.6 Registers Not Initialized

MCU Name	Register Not Initialized
H8/38099F H8/38799F	IEGR, IENR1, IENR2, INTM, IRR1, IRR2, IWPR, CKSTPR1, CKSTPR2, CKSTPR3

23. Updating the I/O Register Window and Memory Window during Debugging

Registers such as the ICDRR of the IIC Bus Interface Controller 2 (IIC2) and the RDR of Serial Communications Interface 3 (SCI3) are affected by the generation of read cycles. Displaying the contents of such peripheral function registers in the I/O register window or the memory window can lead to malfunctions of the peripheral function.

Notes on Connecting the H8/38524F

Section 1 Inside the E8a Emulator User's Manual

The E8a emulator (hereafter referred to as E8a in this document) manual consists of two documents: the E8a User's Manual and the E8a Additional Document for User's Manual (this document). Be sure to read BOTH documents before using the E8a emulator.

(1) E8a Emulator User's Manual

The E8a Emulator User's Manual describes the hardware specifications and how to use the emulator debugger.

- E8a emulator hardware specifications
- Connecting the E8a emulator to the host computer or user system
- Operating the E8a emulator debugger
- Tutorial: From starting up the E8a emulator debugger to debugging

(2) E8a Additional Document for User's Manual

The E8a Additional Document for User's Manual describes content dependent on the MCUs and precautionary notes.

- Example of the E8a emulator connection or interface circuit necessary for designing the hardware
- Notes on using the E8a emulator
- Setting the E8a emulator debugger during startup

Section 2 Connecting the Emulator with the User System

Before connecting an E8a emulator (hereafter referred to as emulator) with the user system, a connector must be installed in the user system so that an user system interface cable can be connected. When designing the user system, refer to the connector and recommended circuits shown in this manual.

Before designing the user system, be sure to read the E8a emulator user's manual and the hardware manual for related MCUs.

Table 2.1 shows the recommended connector for the emulator.

Table 2.1 Recommended Connector

Type Number	Manufacturer	Specifications
2514-6002	3M Limited	14-pin straight type

Connect pins 2, 4, 6, 10, 12, and 14 of the user system connector to GND firmly on the PCB. These pins are used as electrical GND and to monitor the connection of the user system connector. Note the pin assignments of the user system connector.

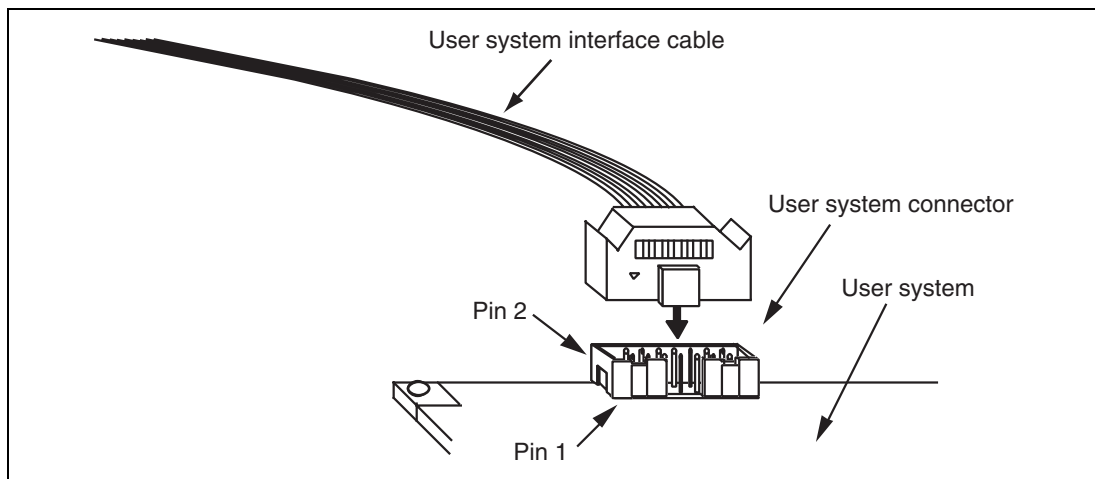

Figure 2.1 Connecting the User System Interface Cable to the User System

- Notes:
1. The pin number assignments of the 14-pin connector differ from those of the E10A-USB emulator; however, the physical location is the same.
 2. Do not place any components within 3 mm of the connector.
 3. When the emulator is used in the [Program Flash] mode, connect the emulator similarly to the user system.

Section 3 Pin Assignments of the E8a Connector

Figure 3.1 shows the pin assignments of the connector.

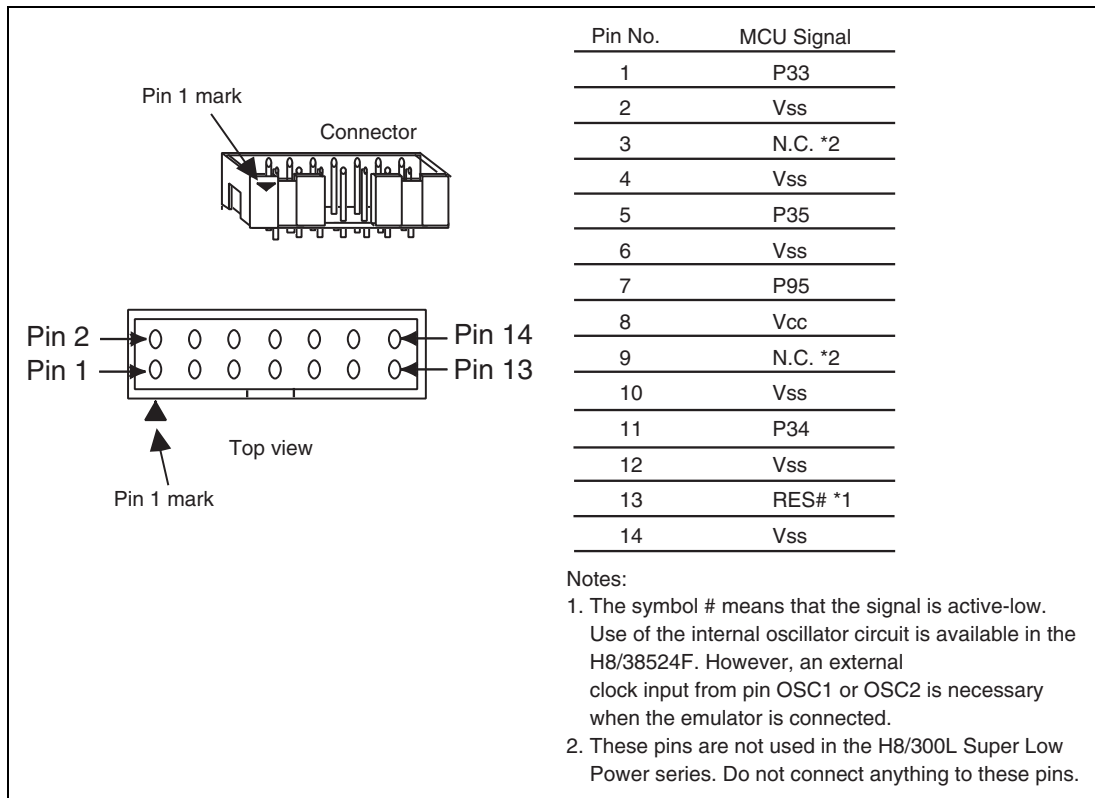

Figure 3.1 Pin Assignments of the Connector

Section 4 Example of Emulator Connection

The figures shown below are examples of connecting the user system to the emulator. The H8/38524F incorporates a power-on reset circuit (hereafter referred to as POR). See figure 4.1 when you use the POR function or figure 4.2 when you do not use the POR function, respectively.

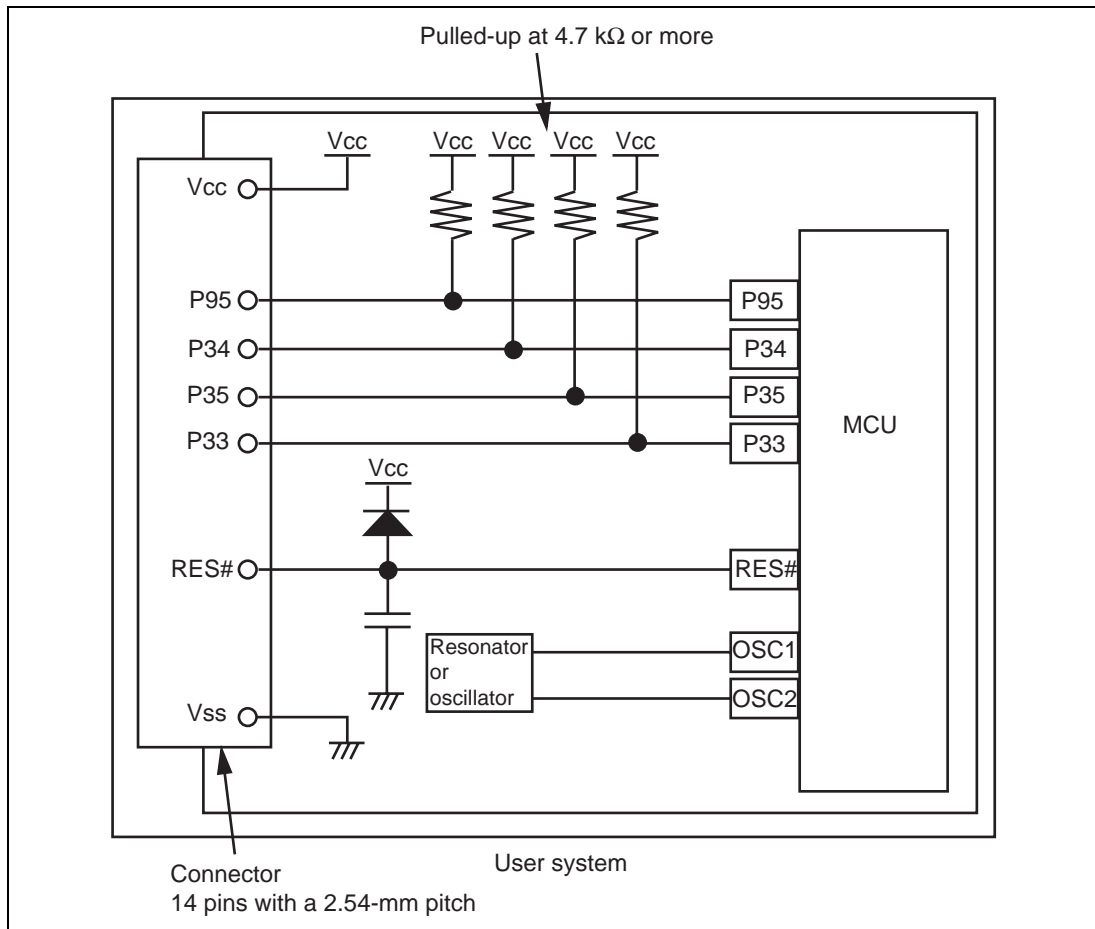

Figure 4.1 Example of Emulator Connection (when a POR is in Use)

Notes: 1. Pins P33 to P35 are used by the emulator. Pull up and connect the emulator and MCU pins.

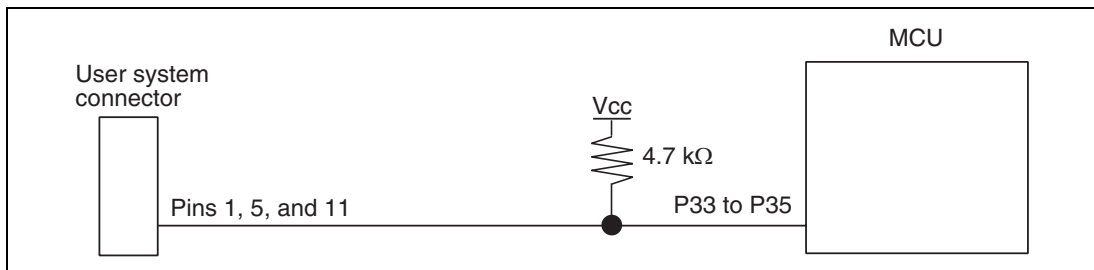

Figure 4.3 Connection of Emulator and Pins P33 to P35

2. Pin P95 is used for forced break control by the emulator. Connect the emulator and MCU pins directly.

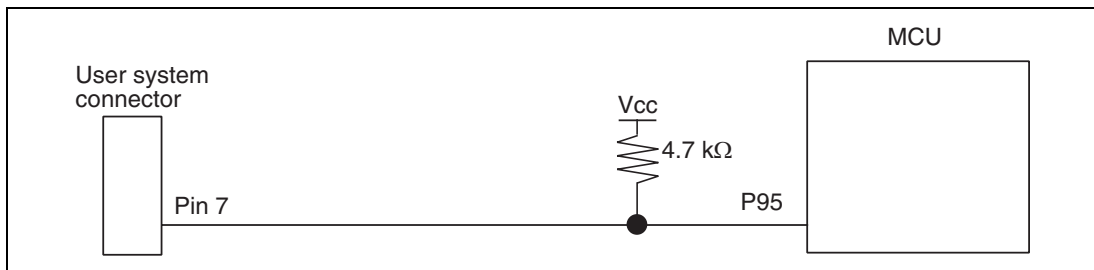

Figure 4.4 Connection of Emulator and Pin P95

3. The RES# pin is used by the emulator. Create the following circuit by connecting the open-collector output buffer so that a reset input from the emulator can be accepted:

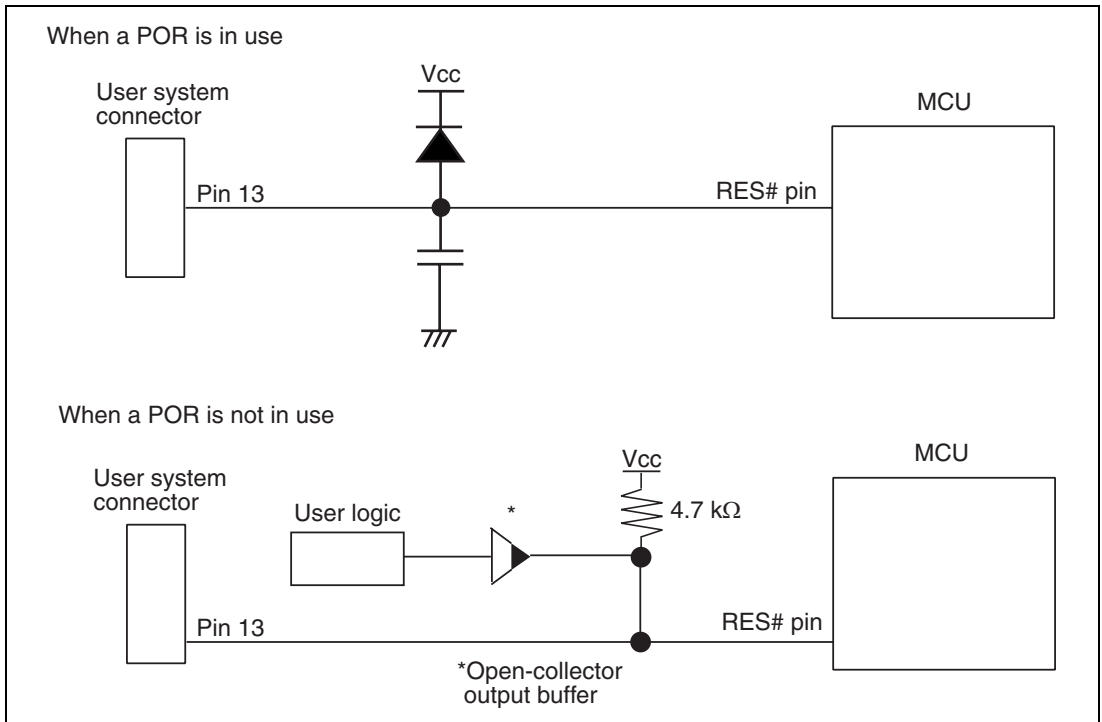

Figure 4.5 Examples of Reset Circuits

4. Connect Vss and Vcc with the Vss and Vcc of the MCU, respectively (within the guaranteed range of the microcomputer).
When the power-supply mode is used, the power is supplied to the user system. Check that the power consumption or voltage of the user system is within the available range of E8a and avoid a problem such as closing of the power-supply circuit.
5. Connect nothing with N.C.
6. Refer to the hardware manual for the recommended capacitance of the capacitor that is connected to the RES# pin.
7. Use of the internal oscillator circuit is available in the H8S/38524F. However, an external clock input from pin OSC1 or OSC2 is necessary when the emulator is connected.

 **WARNING**

In the power-supply mode, connect the emulator after checking that the power-supply circuit on the user system is not closed or the pin number assignments of the user system connector is correct.

Failure to do so will result in a FIRE HAZARD and will damage the host computer, the emulator, and the user system.

7. When the MCU in use is connected to the emulator, the pin functions listed below are not available.

Table 4.1 Pin Functions Not Available

H8/38524F

P33 to P35 and P95

8. Figure 4.6 shows the interface circuit in the E8a emulator. Use this figure as a reference when determining the pull-up resistance value.

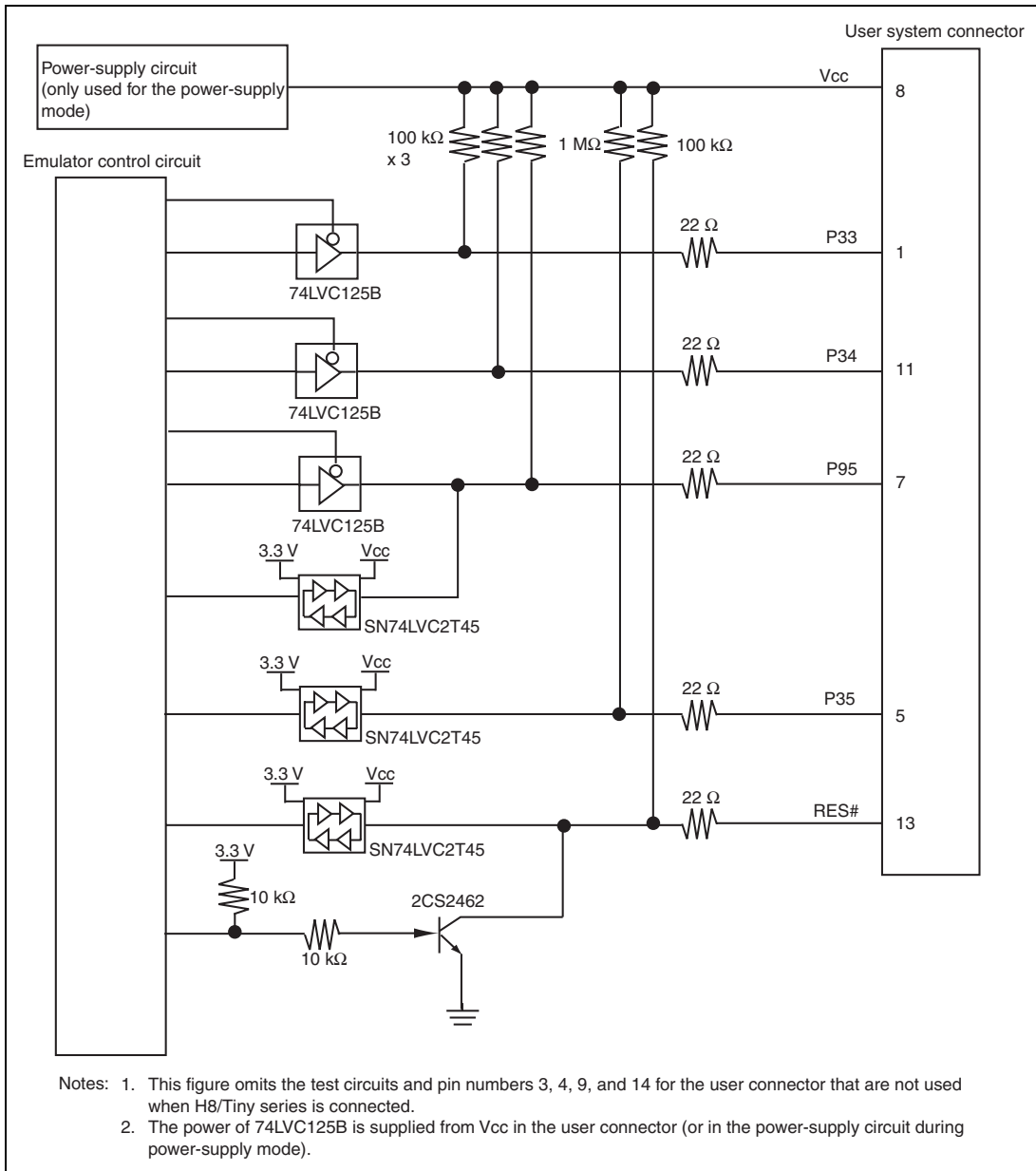

Figure 4.6 Interface Circuit in the E8a Emulator (Reference)

Section 5 Differences between the MCU (H8/38524F) and the Emulator

This section describes the differences between the emulator and MCU operations.

1. [Emulator Setting] Dialog Box

The [Emulator Setting] dialog box is provided for setting the items that need to be set when the emulator starts up (settings are saved in the session).

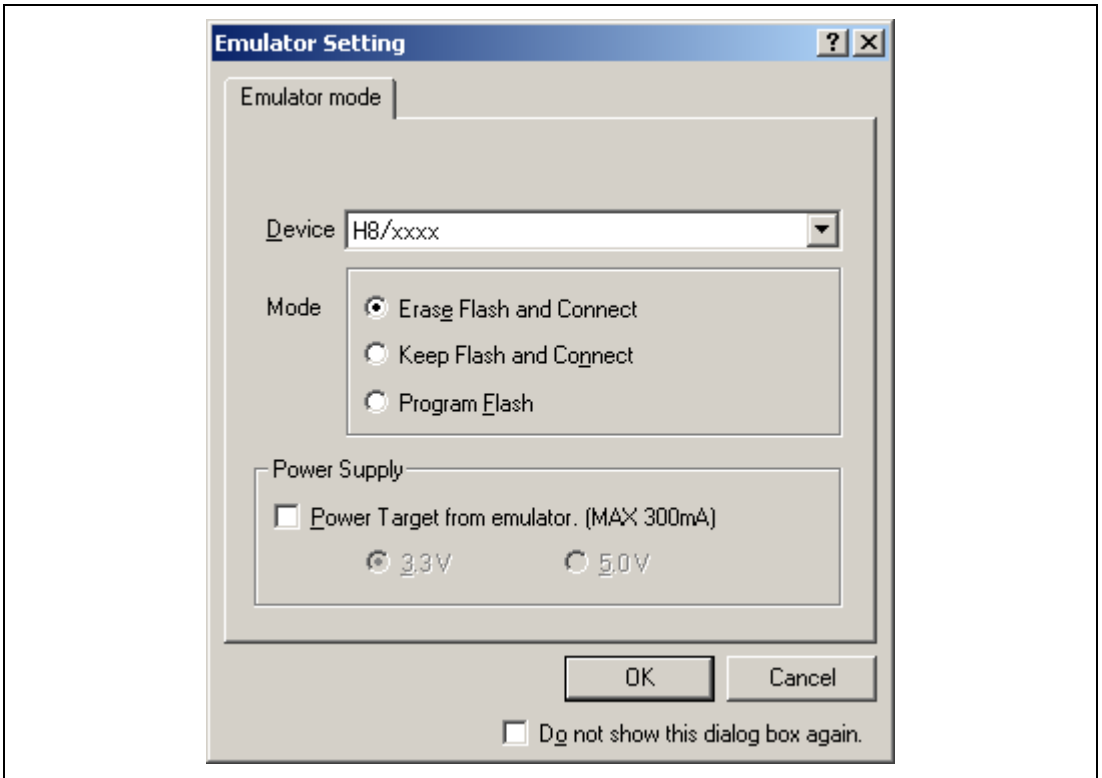

Figure 5.1 [Emulator Setting] Dialog Box

To keep the [Emulator Setting] dialog box closed next time the emulator is started, check "Do not show this dialog box again." at the bottom of the [Emulator Setting] dialog box. You can open the [Emulator Setting] dialog box using either one of the following methods:

- After the emulator gets started, select Menu - [Setup] -> [Emulator] -> [Emulator Setting...].
- Start the emulator while holding down the Ctrl key.
- After the emulator gets started and an error occurred, restart the emulator.

When you check "Do not show this dialog box again.", the emulator doesn't supply power to the user system. To use this check box, start the emulator after turning on the power.

2. Emulator Mode

The selection of the device, the specification of the mode, and the setting of the power supply are done in the [Emulator mode] page of the [Emulator Setting] dialog box.

— Device

Select the device name in use from the [Device] combo box. The following items are selected in the [Mode] group box.

— Modes

- Erase Flash and Connect

This mode is used when there is no emulator program in the flash memory of the target device. In this mode, data of the flash memory of the target device is erased when the emulator is activated. Select this item when the emulator is firstly activated, the version of the emulator's software is updated, or the ID code is changed.

- Keep Flash and Connect

This mode is used when there is an emulator program in the flash memory of the target device. Enter the ID code specified above ('Erase Flash and Connect'). If an incorrect code is entered, all the programs on the flash memory will be erased.

Note: When the emulator gets started in this mode after selecting "Do not show this dialog box again.", the initial values of the ID code is '0E8a' for the E8a emulator. If you use the ID code other than the initial value, do not use "Do not show this dialog box again."

- Program Flash

This mode is used when the emulator is used for programming the flash memory. Debugging the program is disabled. To download the load module, register it in the workspace.

Note: In the H8/Tiny or H8/Super Low Power device, the ID code is not entered in the Program Flash mode.

— Power Supply

When [Power Target from emulator. (MAX 300mA)] is checked, power will be supplied to the user system up to 300 mA. Then select 3.3 V or 5.0 V according to the power voltage of the user system.

3. Emulator Activation and ID Code

In the H8/Tiny- or H8/Super Low Power-series MCU, the [System Clock] and [ID Code] dialog boxes are set when the emulator is activated.

— Setting the system clock

Enter the clock value input to the board in use. The initial value differs in each MCU.

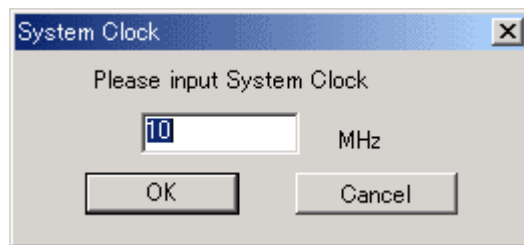

Figure 5.2 [System Clock] Dialog Box

— Setting the ID code

When the emulator is activated in the [Erase Flash and Connect] mode, enter any hexadecimal four-digit ID code to be set (except for H'FFFF). The initial value is H'0E8A. When the emulator is activated in the [Keep Flash and Connect] mode, enter the correct ID code. If an incorrect ID code is entered, all the contents of the flash memory will be erased. In this case, restart the emulator in the [Erase Flash and Connect] mode.

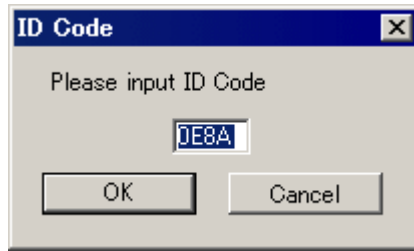

Figure 5.3 [ID Code] Dialog Box

4. When the emulator system is initiated, it initializes the general registers and part of the control registers as shown in table 5.1.

Table 5.1 Register Initial Values at Emulator Power-On

Register	Initial Value
PC	Reset vector value in the vector address table
ER0 to ER6	H'0000
ER7	H'FF80
CCR	H'80

5. Low-power Mode

During a user program break, the CPU operating frequency is forced to a system clock (ϕ) for high-speed operation.

6. RES# Signal

The RES# signal is only valid during user program execution started with clicking the GO or STEP-type button. During a user program break, the RES# signal is not sent to the MCUs.

Note: Do not start user program execution or access the memory while control input signal (RES#) is being low. A TIMEOUT error will occur.

7. System Control Register

In the emulator, the internal I/O registers can be accessed from the [IO] window. However, be careful when accessing the system control register. The emulator saves the register value of the system control register at a break and returns the value when the user program is executed. Since this is done during a break, do not rewrite the system control register in the [IO] window.

8. Memory Access during Emulation

If the memory contents are referenced or modified during emulation, realtime emulation cannot be performed because the user program is temporarily halted.

9. The emulator communicates with the MCUs by using the RES#, P33 to P35, and P95 pins. These pins except for RES# cannot be used.

10. Sum Data Displayed in the Program Flash Mode

Sum data, which is displayed in the 'Program Flash' mode, is a value that data in the whole ROM areas has been added by byte (including data in the dedicated ROM area for the emulator).

11. Note on Executing the User Program

The set value is rewritten since the emulator uses flash memory and watchdog timer registers during programming (Go, Step In, Step Out, or Step Over) of the flash memory.

12. The power consumed by the MCU can reach several milliamperes. This is because the user power supply drives ICs to make the communication signal level match the user-system power-supply voltage. The power consumed rises little during user program execution since the emulator does not perform communication; it rises more during a break.

13. Program Area for the Emulator

Do not access a part of areas in the flash memory or the internal RAM since the emulator program uses these areas. If the contents of the program area for the emulator are changed, the emulator will not operate normally. In this case, restart the emulator with the Erase Flash and Connect mode.

Table 5.2 Program Area for the E8a Emulator

MCU Name	Program Area
H8/38524F	Flash memory: H'7000 to H'7FFF Internal RAM: H'F780 to H'FB7F Vector, etc.: H'0002 to H'0007, H'0014 to H'0015, H'7FF8 to H'7FF9

14. The emulator uses a two-word stack pointer for values stored on a user program break. Therefore, the stack area must accept two-word addresses.

15. Do not use an MCU that has been used for debugging.

If the flash memory is rewritten many times, data may be lost due to retention problems after the emulator has been left for a few days and the data will be erased. If an error message is displayed, exchange the MCU for a new one.

16. Use of the internal oscillator circuit is available in the H8S/38524F. However, an external clock input from pin OSC1 or OSC2 is necessary when the emulator is connected.

17. Items Set in the [Configuration] Dialog Box

The emulator operation conditions are set in the [Configuration] dialog box.

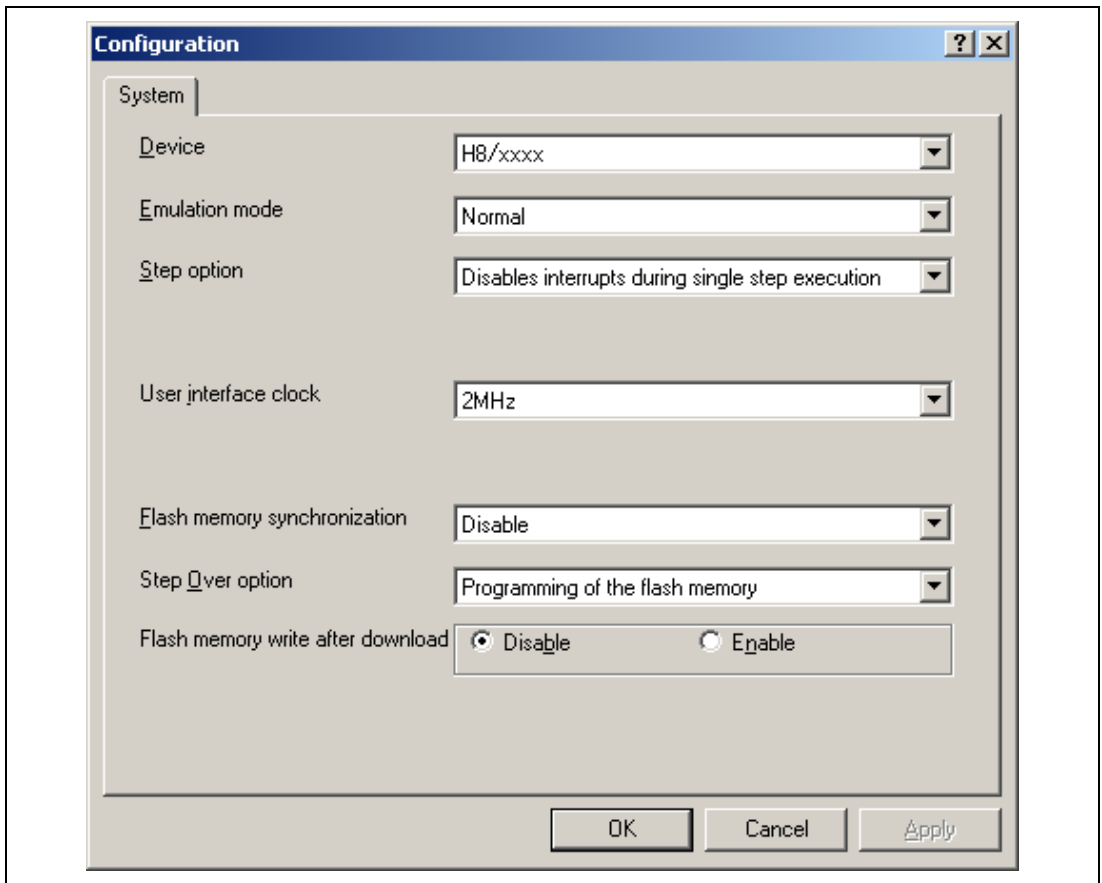

Figure 5.4 [Configuration] Dialog Box ([System] Page)

Items that can be displayed in this dialog box are listed below.

[Device] combo box	Displays the MCU name.
[Emulation mode] combo box	Selects the emulation mode at user program execution. Select Normal to perform normal emulation. Select No break to disable PC breakpoint or break condition settings during emulation.
[Step option] combo box	Sets the step interrupt option. Disable interrupts during single step execution: Disables interrupts ^{*1} during step execution. Enable interrupts during single step execution: Enables interrupts ^{*1} during step execution.
[User interface clock] combo box	Displays the transfer clock of the user interface.
[Flash memory synchronization] combo box	Selects whether or not the contents of the flash memory are acquired by the emulator when the user program is stopped or the position where the PC break is set is put back as the original code. When the flash memory is not programmed by the user program, its contents need not be acquired by the emulator.

If there is no problem with the state that the program in the flash memory has been replaced as the PC break code, the position where the PC break is set needs not be put back as the original code.

Disable: Read or program is not performed for the flash memory except when the emulator is activated, the flash memory area is modified, and the settings of the PC break to the flash memory area are changed.

PC to flash memory: When the user program is stopped, the specified PC break code is replaced as the original instruction. Select this option if there is a problem with the state that the program in the flash memory has been replaced as the PC break code.

Flash memory to PC: When the user program is stopped, the contents of the flash memory are read by the emulator. Select this option if the flash memory is reprogrammed by the user program.

PC to flash memory, Flash memory to PC:
When the user program is stopped, the contents of the flash memory are read by the emulator and the specified PC break code is replaced as the original instruction. Select this option if the flash memory is reprogrammed by the user program and there is a problem with the state that the program in the flash memory has been replaced as the PC break code.

[Step Over option] combo box

Enables or disables programming of the flash memory while executing step operation.

Programming of the flash memory: Uses a software break for step operation (e.g. Step Over) and enables programming of the flash memory.

No Programming of the flash memory: Uses Break Condition for step operation (e.g. Step Over) and disables programming of the flash memory^{*2}.

[Flash memory write after download] group box

Enables or disables programming of the flash memory after downloading the program.

Disable: Disables programming of the flash memory after downloading the program.

Enable: Enables programming of the flash memory after downloading the program.

- Notes:
1. Includes interrupts in a break.
 2. When Step Over is performed after selecting [No Programming of the flash memory] for [Step Over option], the instruction that follows a JSR, BSR, or TRAPA instruction will also be executed. If there are consecutive JSR, BSR, or TRAPA instructions, execution proceeds until it reaches an instruction that is not JSR, BSR, or TRAPA. (When there are consecutive function calls in C language, the program steps all of these functions.)

18. Initializing the Internal I/O Register with the Reset_CPU Function

Be sure to initialize the internal I/O registers shown below by the user program since they are not initialized by selecting [Debug] – [Reset CPU] or using the RESET command.

Table 5.3 Registers Not Initialized

MCU Name	Register Not Initialized
H8/38524F	SYSCR1, SYSCR2, IEGR1, IENR2, IENR1, IRR1, IRR2, IWPR, TMW, CKSTPR1, CKSTPR2

Notes on Connecting the H8/38537F

Section 1 Inside the E8a Emulator User's Manual

The E8a emulator (hereafter referred to as E8a emulator in this document) manual consists of two documents: the E8a User's Manual and the E8a Additional Document for User's Manual (this document). Be sure to read BOTH documents before using the E8a emulator.

(1) E8a Emulator User's Manual

The E8a Emulator User's Manual describes the hardware specifications and how to use the emulator debugger.

- E8a emulator hardware specifications
- Connecting the E8a emulator to the host computer or user system
- Operating the E8a emulator debugger
- Tutorial: From starting up the E8a emulator debugger to debugging

(2) E8a Additional Document for User's Manual

The E8a Additional Document for User's Manual describes content dependent on the MCUs and precautionary notes.

- Example of the E8a emulator connection or interface circuit necessary for designing the hardware
- Notes on using the E8a emulator
- Setting the E8a emulator debugger during startup

Section 2 Connecting the Emulator with the User System

Before connecting an E8a emulator (hereafter referred to as emulator) with the user system, a connector must be installed in the user system so that an user system interface cable can be connected. When designing the user system, refer to the connector and recommended circuits shown in this manual.

Before designing the user system, be sure to read the E8a emulator user's manual and the hardware manual for related MCUs.

Table 2.1 shows the recommended connector for the emulator.

Table 2.1 Recommended Connector

Type Number	Manufacturer	Specifications
2514-6002	3M Limited	14-pin straight type

Connect pins 2, 4, 6, 10, 12, and 14 of the user system connector to GND firmly on the PCB. These pins are used as electrical GND and to monitor the connection of the user system connector. Note the pin assignments of the user system connector.

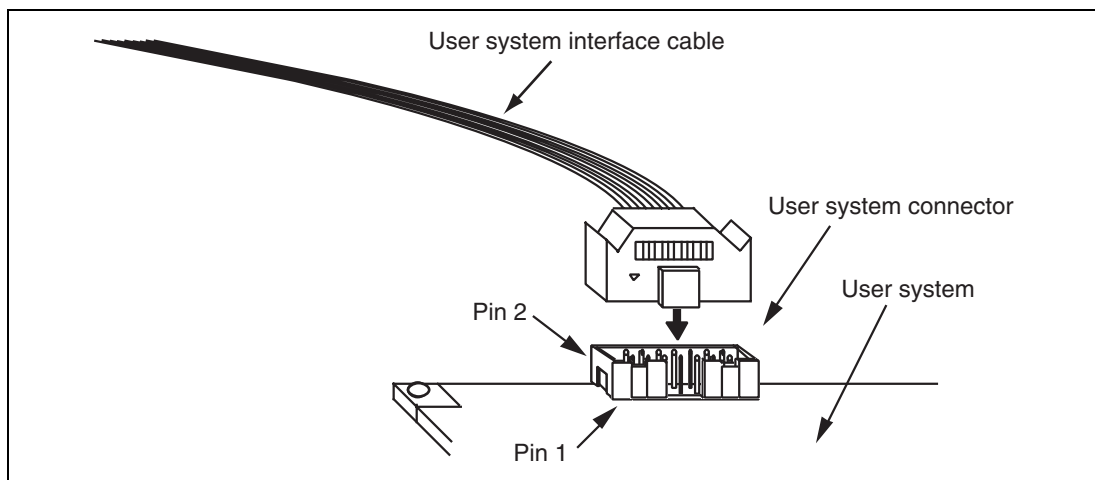

Figure 2.1 Connecting the User System Interface Cable to the User System

- Notes:
1. The pin number assignments of the 14-pin connector differ from those of the E10A-USB emulator; however, the physical location is the same.
 2. Do not place any components within 3 mm of the connector.
 3. When the emulator is used in the [Program Flash] mode, connect the emulator similarly to the user system.

Section 3 Pin Assignments of the E8a Connector

Figure 3.1 shows the pin assignments of the emulator's connector.

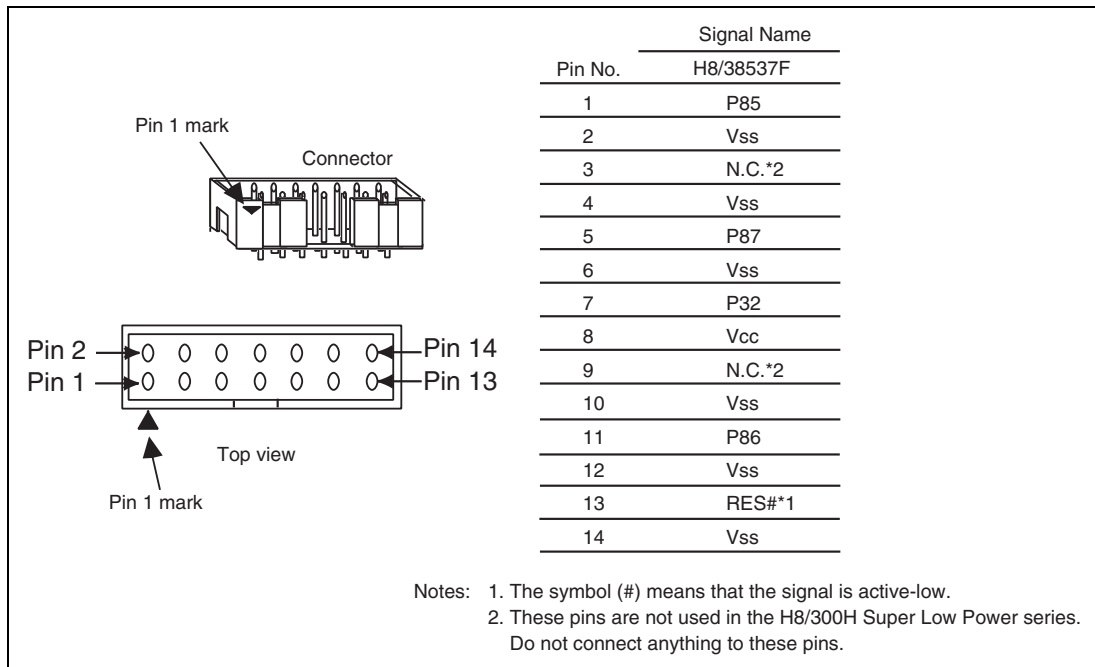

Figure 3.1 Pin Assignments of the Emulator's Connector

Section 4 Example of Emulator Connection

Figure 4.1 shows an example of emulator connection to the MCU.

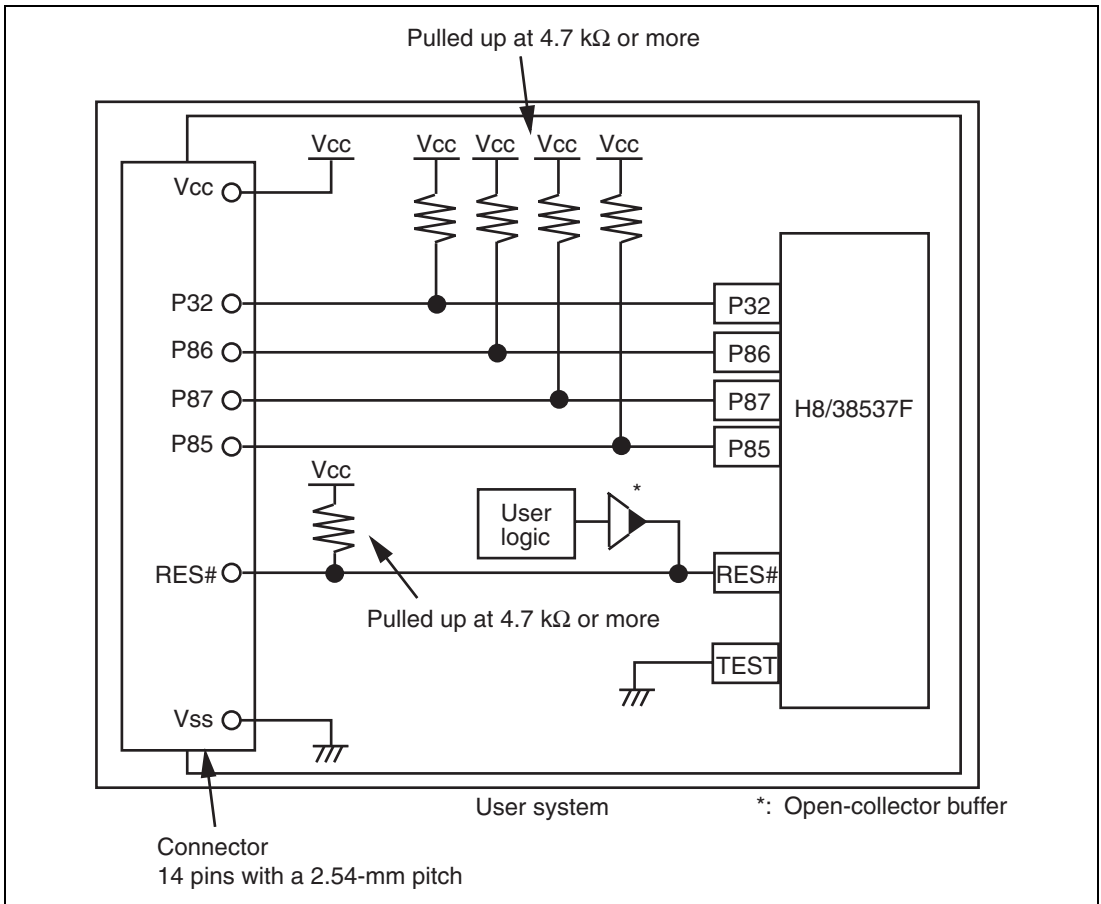

Figure 4.1 Example of Emulator Connection (H8/38537F)

Notes: 1. P85 to P87 pins are used by the emulator. Pull up and connect the emulator and MCU pins.

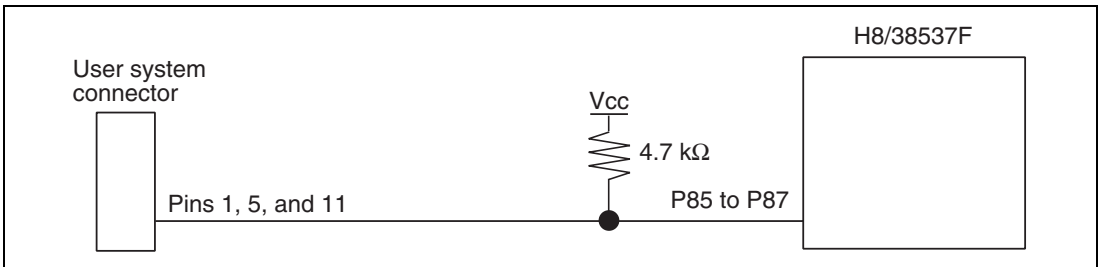

Figure 4.2 Connection of Emulator and P85 to P87 Pins

2. The P32 pin is used for forced break control by the emulator. Connect the emulator and MCU pins directly.

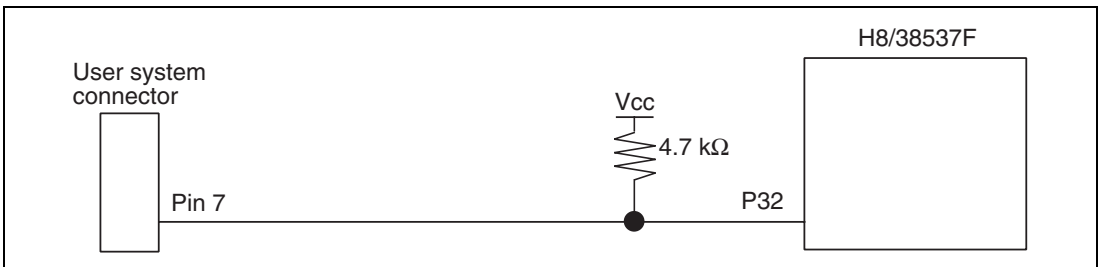

Figure 4.3 Connection of Emulator and P32 Pin

3. The RES# pin is used by the emulator. Create the following circuit by connecting the open-collector output buffer so that reset input can be accepted from the emulator.

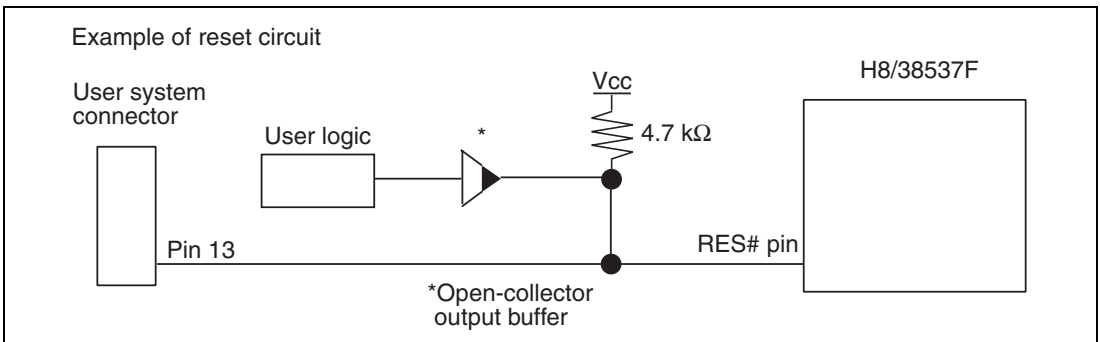

Figure 4.4 Example of a Reset Circuit

4. Connect Vss and Vcc with the Vss and Vcc of the MCU, respectively.
The input voltage, Vcc, must be connected to the user system Vcc (power supply).
The amount of voltage permitted to input to Vcc must be within the guaranteed range of the microcomputer.
5. Connect nothing with N.C.



WARNING

In the power-supply mode, connect the emulator after checking that the power-supply circuit on the user system is not closed or the pin number assignments of the user system connector is correct.

Failure to do so will result in a FIRE HAZARD and will damage the host computer, the emulator, and the user system.

6. When the MCU in use is connected to the emulator, the pin functions listed below are not available.

Table 4.1 Pin Functions Not Available

H8/38537F

P85 to P87 and P32

SEG30 to SEG32

7. Figure 4.5 shows the interface circuit in the E8a emulator. Use this figure as a reference when determining the pull-up resistance value.

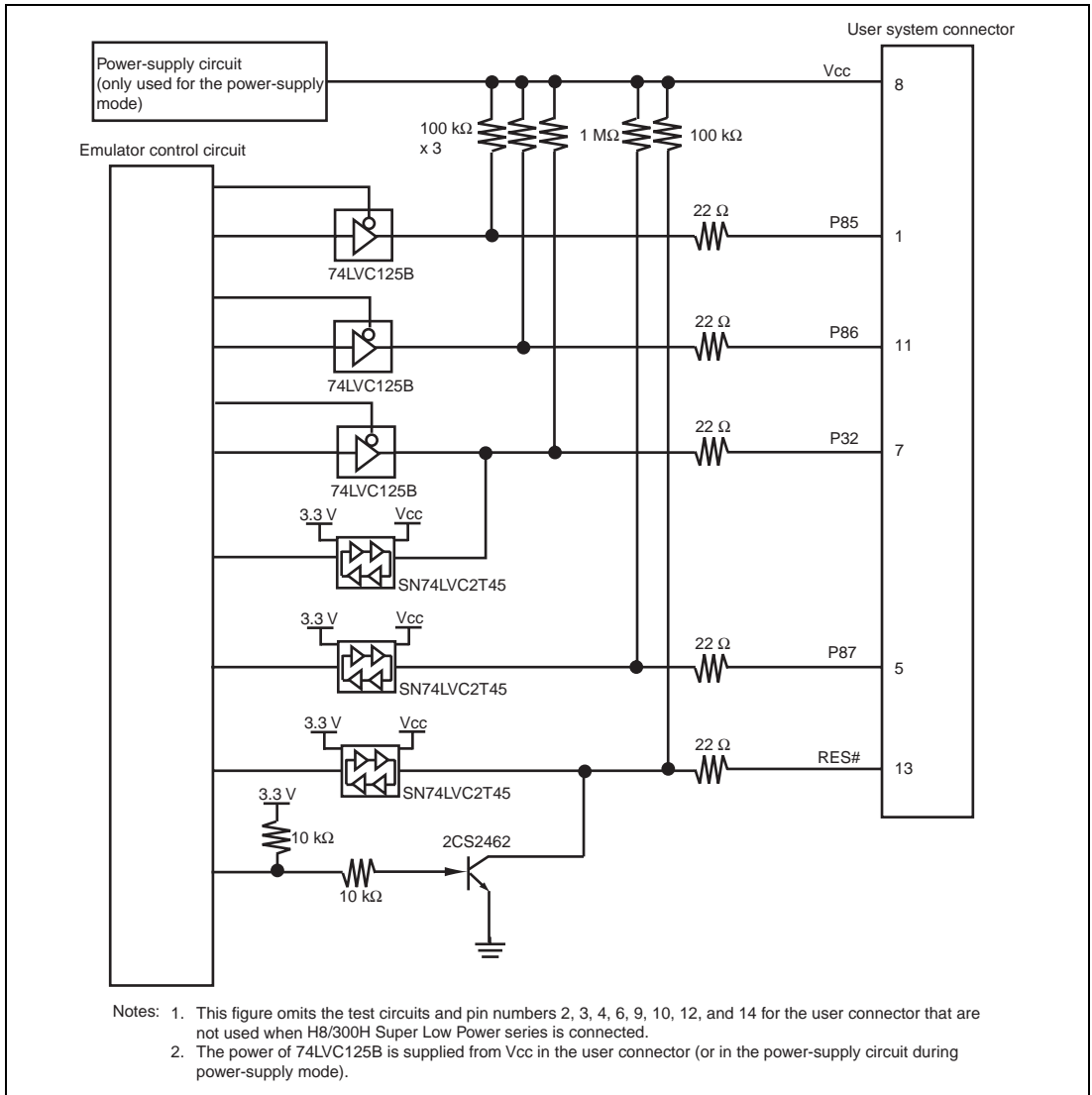

Figure 4.5 Interface Circuit in the E8a Emulator (Reference)

Section 5 Differences between the MCU (H8/38537F) and the Emulator

This section describes the differences between the emulator and MCU operations.

1. [Emulator Setting] Dialog Box

The [Emulator Setting] dialog box is provided for setting the items that need to be set when the emulator starts up (settings are saved in the session).

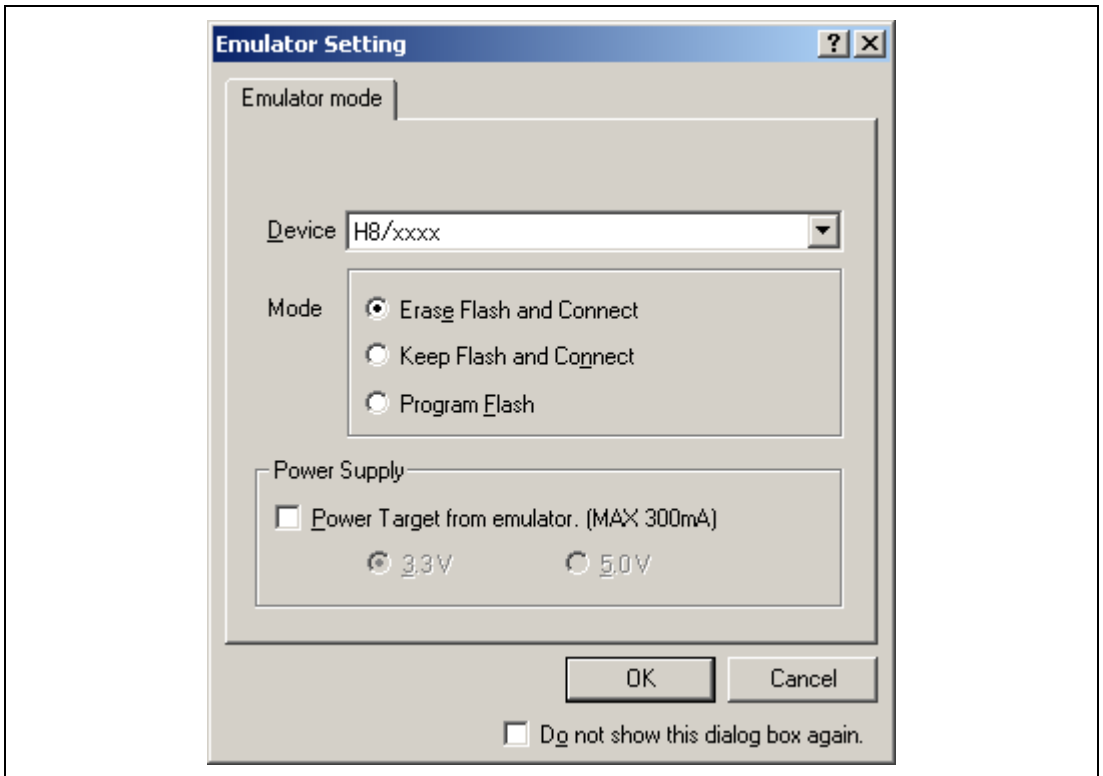

Figure 5.1 [Emulator Setting] Dialog Box

To keep the [Emulator Setting] dialog box closed next time the emulator is started, check "Do not show this dialog box again." at the bottom of the [Emulator Setting] dialog box. You can open the [Emulator Setting] dialog box using either one of the following methods:

- After the emulator gets started, select Menu - [Setup] -> [Emulator] -> [Emulator Setting...].
- Start the emulator while holding down the Ctrl key.
- After the emulator gets started and an error occurred, restart the emulator.

When you check "Do not show this dialog box again.", the emulator doesn't supply power to the user system. To use this check box, start the emulator after turning on the power.

2. Emulator Mode

The selection of the device, the specification of the mode, and the setting of the power supply are done in the [Emulator mode] page of the [Emulator Setting] dialog box.

— Device

Select the device name in use from the [Device] combo box. The following items are selected in the [Mode] group box.

— Modes

- Erase Flash and Connect

This mode is used when there is no emulator program in the flash memory of the target device. In this mode, data of the flash memory of the target device is erased when the emulator is activated. Select this item when the emulator is firstly activated, the version of the emulator's software is updated, or the ID code is changed.

- Keep Flash and Connect

This mode is used when there is an emulator program in the flash memory of the target device. Enter the ID code specified above ('Erase Flash and Connect'). If an incorrect code is entered, all the programs on the flash memory will be erased.

Note: When the emulator gets started in this mode after selecting "Do not show this dialog box again.", the initial values of the ID code is '0E8a' for the E8a emulator. If you use the ID code other than the initial value, do not use "Do not show this dialog box again.".

- Program Flash

This mode is used when the emulator is used for programming the flash memory. Debugging the program is disabled. To download the load module, register it in the workspace.

Note: In the H8/Tiny or H8/Super Low Power device, the ID code is not entered in the Program Flash mode.

- Power Supply

When [Power Target from emulator. (MAX 300mA)] is checked, power will be supplied to the user system up to 300 mA. Then select 3.3 V or 5.0 V according to the power voltage of the user system.

3. Emulator Activation and ID Code

In the H8/Tiny- or H8/Super Low Power-series MCU, the [System Clock] and [ID Code] dialog boxes are set when the emulator is activated.

- Setting the system clock

Enter the clock value input to the board in use. The initial value differs in each MCU.

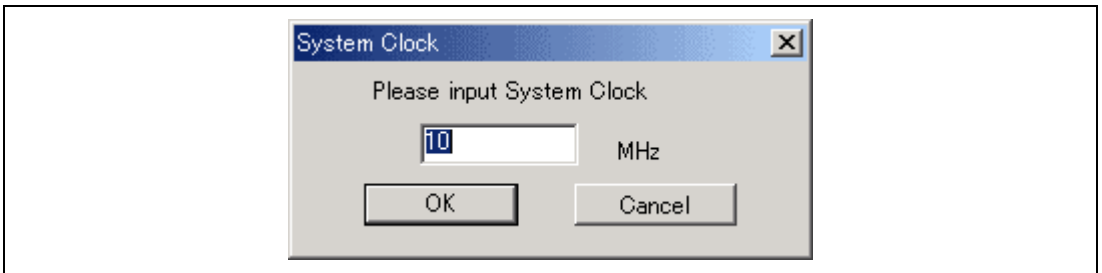

Figure 5.2 [System Clock] Dialog Box

- Setting the ID code

When the emulator is activated in the [Erase Flash and Connect] mode, enter any hexadecimal four-digit ID code to be set (except for H'FFFF). The initial value is H'0E8A. When the emulator is activated in the [Keep Flash and Connect] mode, enter the correct ID code. If an incorrect ID code is entered, all the contents of the flash memory will be erased. In this case, restart the emulator in the [Erase Flash and Connect] mode.

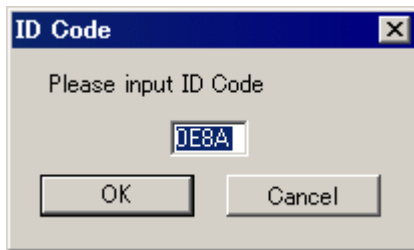

Figure 5.3 [ID Code] Dialog Box

4. When the emulator system is initiated, it initializes the general registers and part of the control registers as shown in table 5.1.

Table 5.1 Register Initial Values at Emulator Power-On

Register	Initial Value
PC	Reset vector value in the vector address table
R0 to R6	H'0000
R7	H'FF80
CCR	H'80

5. Low-power Mode

During a user program break, the CPU operating frequency is forced to a system clock (ϕ) for high-speed operation.

6. RES# Signal

The RES# signal is only valid during user program execution started with clicking the GO or STEP-type button. During a user program break, the RES# signal is not sent to the MCUs.

Note: Do not start user program execution or access the memory while control input signal (RES#) is being low. A TIMEOUT error will occur.

7. System Control Register

In the emulator, the internal I/O registers can be accessed from the [IO] window. However, be careful when accessing the system control register. The emulator saves the register value of the system control register at a break and returns the value when the user program is executed. Since this is done during a break, do not rewrite the system control register in the [IO] window.

8. Memory Access during Emulation

If the memory contents are referenced or modified during emulation, realtime emulation cannot be performed because the user program is temporarily halted.

9. The emulator communicates with the MCUs by using the P85 to P87 and P32, and RES# pins. These pins except for RES# cannot be used.

10. Sum Data Displayed in the Program Flash Mode

Sum data, which is displayed in the 'Program Flash' mode, is a value that data in the whole ROM areas has been added by byte (including data in the dedicated ROM area for the emulator).

11. Note on Executing the User Program

The set value is rewritten since the emulator uses flash memory and watchdog timer registers during programming (Go, Step In, Step Out, or Step Over) of the flash memory.

12. The power consumed by the MCU can reach several milliamperes. This is because the user power supply drives ICs to make the communication signal level match the user-system power-supply voltage. The power consumed rises little during user program execution since the emulator does not perform communication; it rises more during a break.

13. Program Area for the Emulator

Do not access a part of areas in the flash memory or the internal RAM since the emulator program uses these areas. If the contents of the program area for the emulator are changed, the emulator will not operate normally. In this case, restart the emulator with the Erase Flash and Connect mode.

Table 5.2 Program Area for the E8a Emulator

MCU Name	Program Area
H8/38537F	Flash memory: H'E000 to H'EFFF Internal RAM: H'F300 to H'F6FF Vector, etc.: H'0002 to H'0007, H'EFF8 to H'EFF9

14. The emulator uses a two-word stack pointer for values stored on a user program break. Therefore, the stack area must accept two-word addresses.

15. Do not use an MCU that has been used for debugging.

If the flash memory is rewritten many times, data may be lost due to retention problems after the emulator has been left for a few days and the data will be erased. If an error message is displayed, exchange the MCU for a new one.

16. Debugging of the emulator will not be normally performed if bit 2 of PCR3 and bit 2 of PDR3 are rewritten in the user program or the BSET.B and BCLR.B instructions are issued to other than bit 2 in each register.

17. Items Set in the [Configuration] Dialog Box

The emulator operation conditions are set in the [Configuration] dialog box.

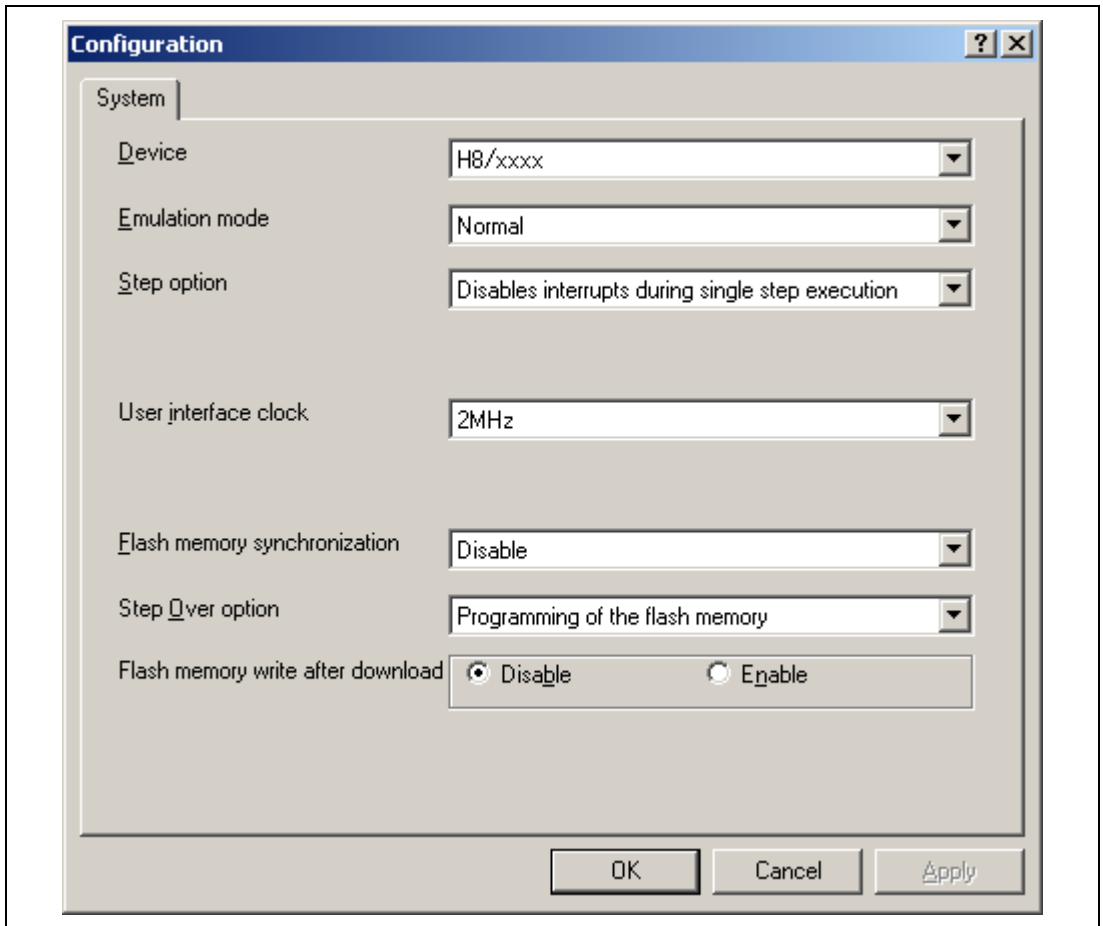

Figure 5.4 [Configuration] Dialog Box ([System] Page)

Items that can be displayed in this dialog box are listed below.

[Device] combo box	Displays the MCU name.
[Emulation mode] combo box	Selects the emulation mode at user program execution. Select Normal to perform normal emulation. Select No break to disable PC breakpoint or break condition settings during emulation.
[Step option] combo box	Sets the step interrupt option. Disable interrupts during single step execution: Disables interrupts ^{*1} during step execution. Enable interrupts during single step execution: Enables interrupts ^{*1} during step execution.
[User interface clock] combo box	Displays the transfer clock of the user interface.
[Flash memory synchronization] combo box	Selects whether or not the contents of the flash memory are acquired by the emulator when the user program is stopped or the position where the PC break is set is put back as the original code. When the flash memory is not programmed by the user program, its contents need not be acquired by the emulator.

If there is no problem with the state that the program in the flash memory has been replaced as the PC break code, the position where the PC break is set needs not be put back as the original code.

Disable: Read or program is not performed for the flash memory except when the emulator is activated, the flash memory area is modified, and the settings of the PC break to the flash memory area are changed.

PC to flash memory: When the user program is stopped, the specified PC break code is replaced as the original instruction. Select this option if there is a problem with the state that the program in the flash memory has been replaced as the PC break code.

Flash memory to PC: When the user program is stopped, the contents of the flash memory are read by the emulator. Select this option if the flash memory is reprogrammed by the user program.

PC to flash memory, Flash memory to PC:

When the user program is stopped, the contents of the flash memory are read by the emulator and the specified PC break code is replaced as the original instruction. Select this option if the flash memory is reprogrammed by the user program and there is a problem with the state that the program in the flash memory has been replaced as the PC break code.

[Step Over option] combo box

Enables or disables programming of the flash memory while executing step operation.

Programming of the flash memory: Uses a software break for step operation (e.g. Step Over) and enables programming of the flash memory.

No Programming of the flash memory: Uses Break Condition for step operation (e.g. Step Over) and disables programming of the flash memory.

[Flash memory write after download] group box

Enables or disables programming of the flash memory after downloading the program.

Disable: Disables programming of the flash memory after downloading the program.

Enable: Enables programming of the flash memory after downloading the program.

Notes: 1. Includes interrupts in a break.

2. When Step Over is performed after selecting [No Programming of the flash memory] for [Step Over option], the instruction that follows a JSR, BSR, or TRAPA instruction will also be executed. If there are consecutive JSR, BSR, or TRAPA instructions, execution proceeds until it reaches an instruction that is not JSR, BSR, or TRAPA. (When there are consecutive function calls in C language, the program steps all of these functions).

18. Initializing the Internal I/O Register with the Reset_CPU Function

Be sure to initialize the internal I/O registers shown below by the user program since they are not initialized by selecting [Debug] – [Reset CPU] or using the RESET command.

Table 5.3 Registers Not Initialized

MCU Name	Register Not Initialized
H8/38537F	SYSCR1, SYSCR2, IEGR, IENR2, IENR1, IRR1, IRR2, IWPR, CKSTPR1, CKSTPR2

19. Available MCUs for E8a Emulator

The H8/38534F is also available for the emulator. When the emulator is activated, set the MCU to be selected as shown in table 5.4. Note that, however, an error will not be displayed even if a program which is larger than the internal ROM capacity is downloaded.

Table 5.4 List of Available MCUs

MCU to be Used	MCU to be Selected
H8/38534F	H8/38537F

20. Restriction on Software Write Enable (SWE) Bit

If the SWE bit is set to 1 during execution of the user program, a communication timeout error will occur. Do not set this bit to 1.

Notes on Connecting the H8/38704F

Section 1 Inside the E8a Emulator User's Manual

The E8a emulator (hereafter referred to as E8a in this document) manual consists of two documents: the E8a User's Manual and the E8a Additional Document for User's Manual (this document). Be sure to read BOTH documents before using the E8a emulator.

(1) E8a Emulator User's Manual

The E8a Emulator User's Manual describes the hardware specifications and how to use the emulator debugger.

- E8a emulator hardware specifications
- Connecting the E8a emulator to the host computer or user system
- Operating the E8a emulator debugger
- Tutorial: From starting up the E8a emulator debugger to debugging

(2) E8a Additional Document for User's Manual

The E8a Additional Document for User's Manual describes content dependent on the MCUs and precautionary notes.

- Example of the E8a emulator connection or interface circuit necessary for designing the hardware
- Notes on using the E8a emulator
- Setting the E8a emulator debugger during startup

Section 2 Connecting the Emulator with the User System

Before connecting an E8a emulator (hereafter referred to as emulator) with the user system, a connector must be installed in the user system so that a user system interface cable can be connected. When designing the user system, refer to the connector and recommended circuits shown in this manual.

Before designing the user system, be sure to read the E8a emulator user's manual and the hardware manual for related MCUs.

Table 2.1 shows the recommended connector for the emulator.

Table 2.1 Recommended Connector

Type Number	Manufacturer	Specifications
2514-6002	3M Limited	14-pin straight type

Connect pins 2, 4, 6, 10, 12, and 14 of the user system connector to GND firmly on the PCB. These pins are used as electrical GND and to monitor the connection of the user system connector. Note the pin assignments of the user system connector.

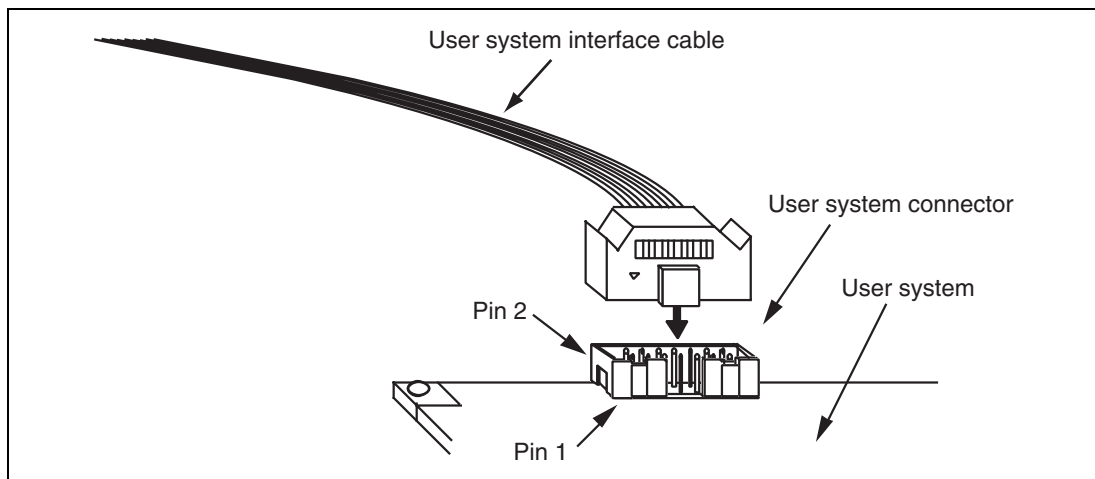

Figure 2.1 Connecting the User System Interface Cable to the User System

- Notes:
1. The pin number assignments of the 14-pin connector differ from those of the E10A-USB emulator; however, the physical location is the same.
 2. Do not place any components within 3 mm of the connector.
 3. When the emulator is used in the [Program Flash] mode, connect the emulator similarly to the user system.

Section 3 Pin Assignments of the E8a Connector

Figure 3.1 shows the pin assignments of the connector.

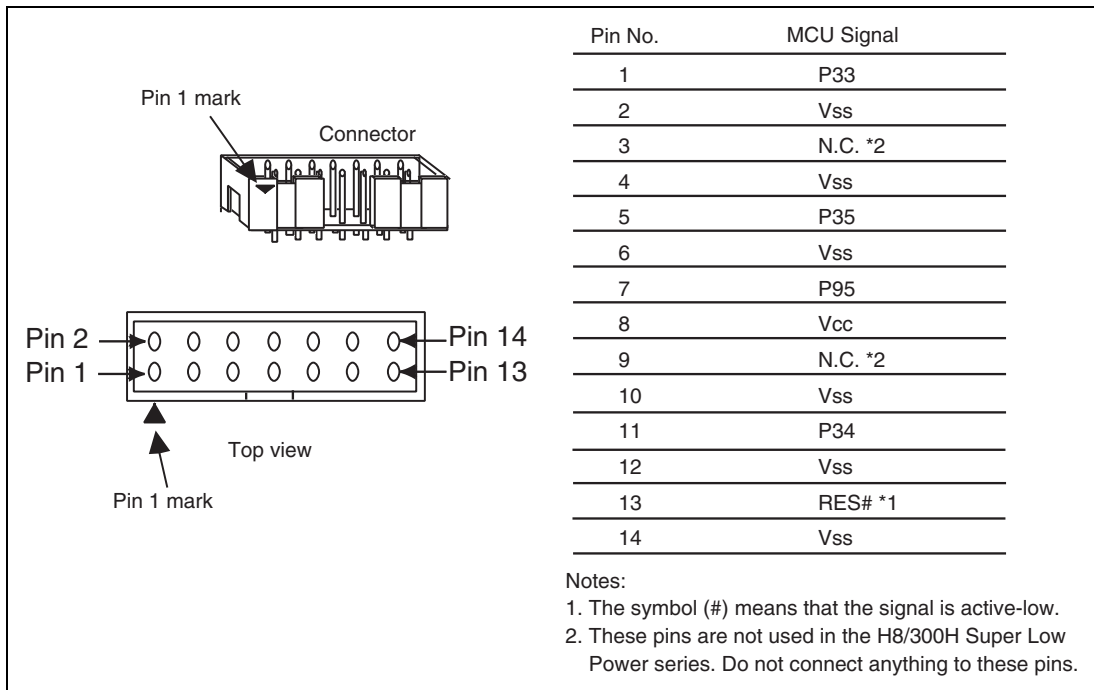

Figure 3.1 Pin Assignments of the Connector

Section 4 Example of Emulator Connection

Figure 4.1 shows an example of emulator connection to the MCU.

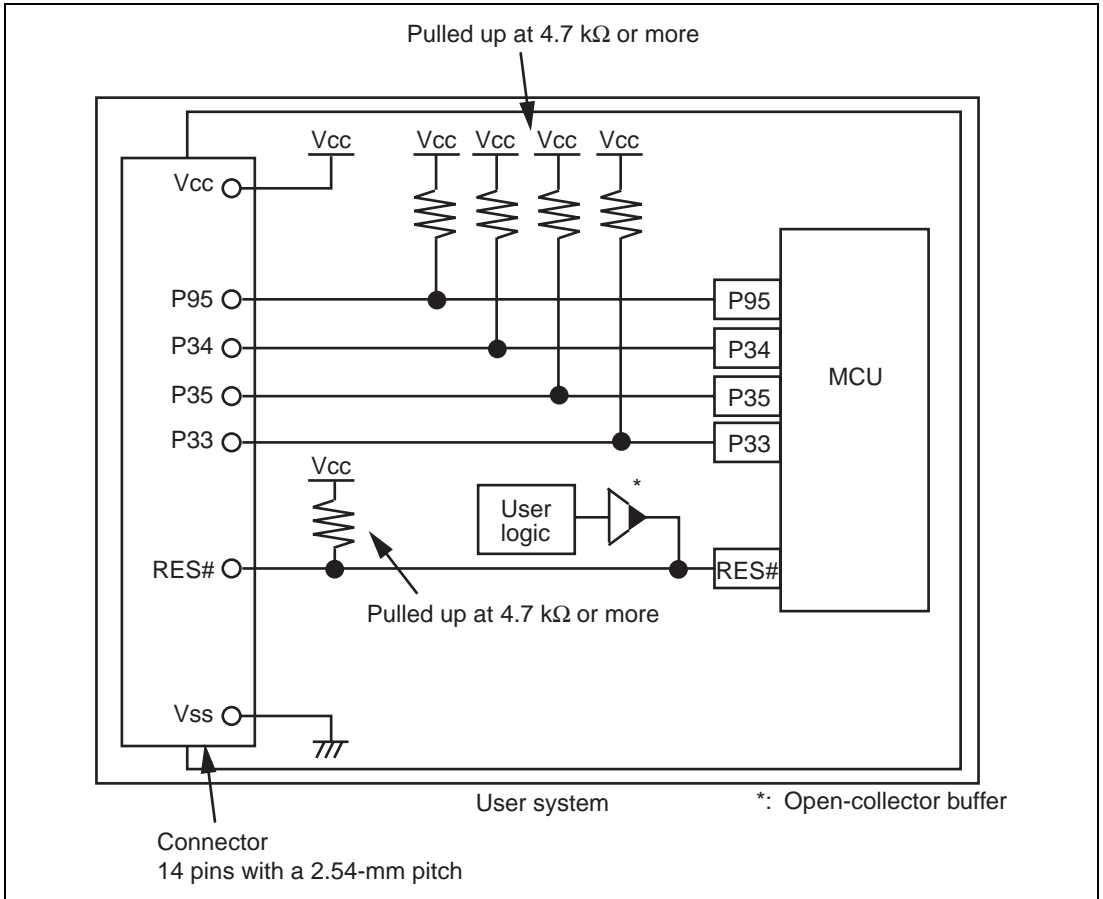

Figure 4.1 Example of Emulator Connection

Notes: 1. P33 to P35 pins are used by the emulator. Pull up and connect the emulator and MCU pins.

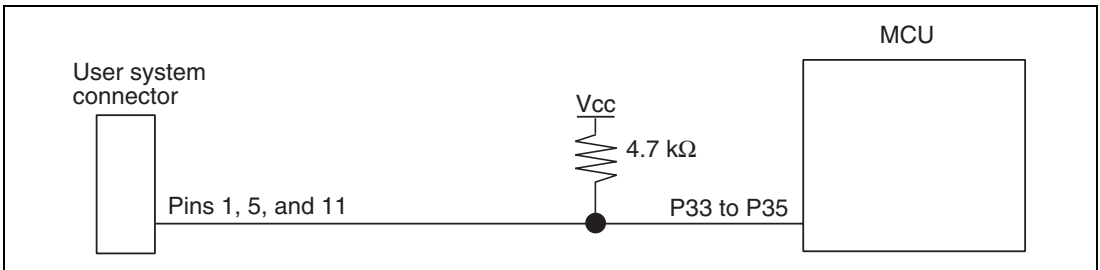

Figure 4.2 Connection of Emulator and P33 to P35 Pins

2. The P95 pin is used for forced break control by the emulator. Connect the emulator and MCU pins directly.

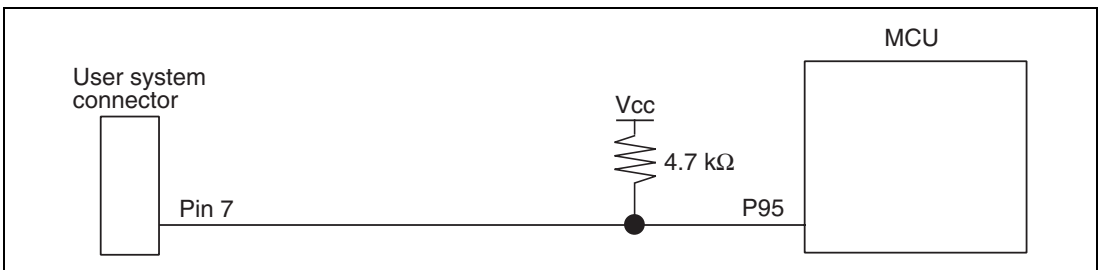

Figure 4.3 Connection of Emulator and P95 Pin

3. The RES# pin is used by the emulator. Create the following circuit by connecting the open-collector output buffer so that reset input can be accepted from the emulator.

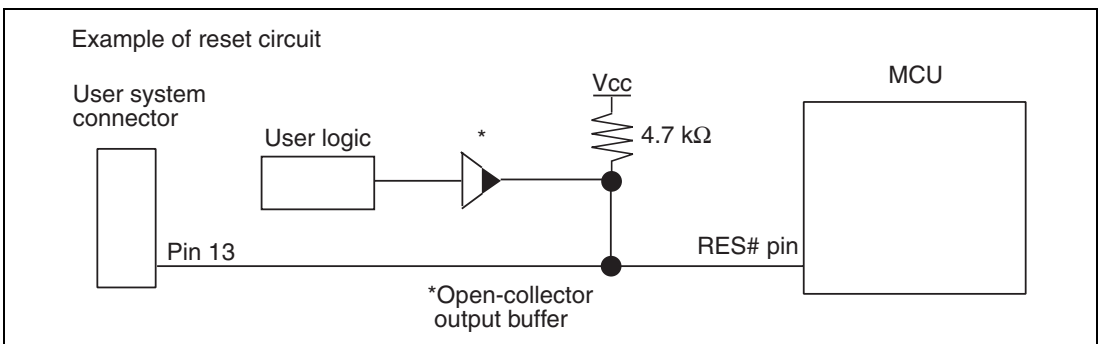

Figure 4.4 Example of a Reset Circuit

4. Connect Vss and Vcc with the Vss and Vcc of the MCU, respectively (within the guaranteed range of the microcomputer).

When the power-supply mode is used, the power is supplied to the user system. Check that the power consumption or voltage of the user system is within the available range of E8a and avoid a problem such as closing of the power-supply circuit.

5. Connect nothing with N.C.

WARNING

In the power-supply mode, connect the emulator after checking that the power-supply circuit on the user system is not closed or the pin number assignments of the user system connector is correct.

Failure to do so will result in a FIRE HAZARD and will damage the host computer, the emulator, and the user system.

6. When the MCU in use is connected to the emulator, the pin functions listed below are not available.

Table 4.1 Pin Functions Not Available

H8/38704F

P33 to P35 and P95

7. Figure 4.5 shows the interface circuit in the E8a emulator. Use this figure as a reference when determining the pull-up resistance value.

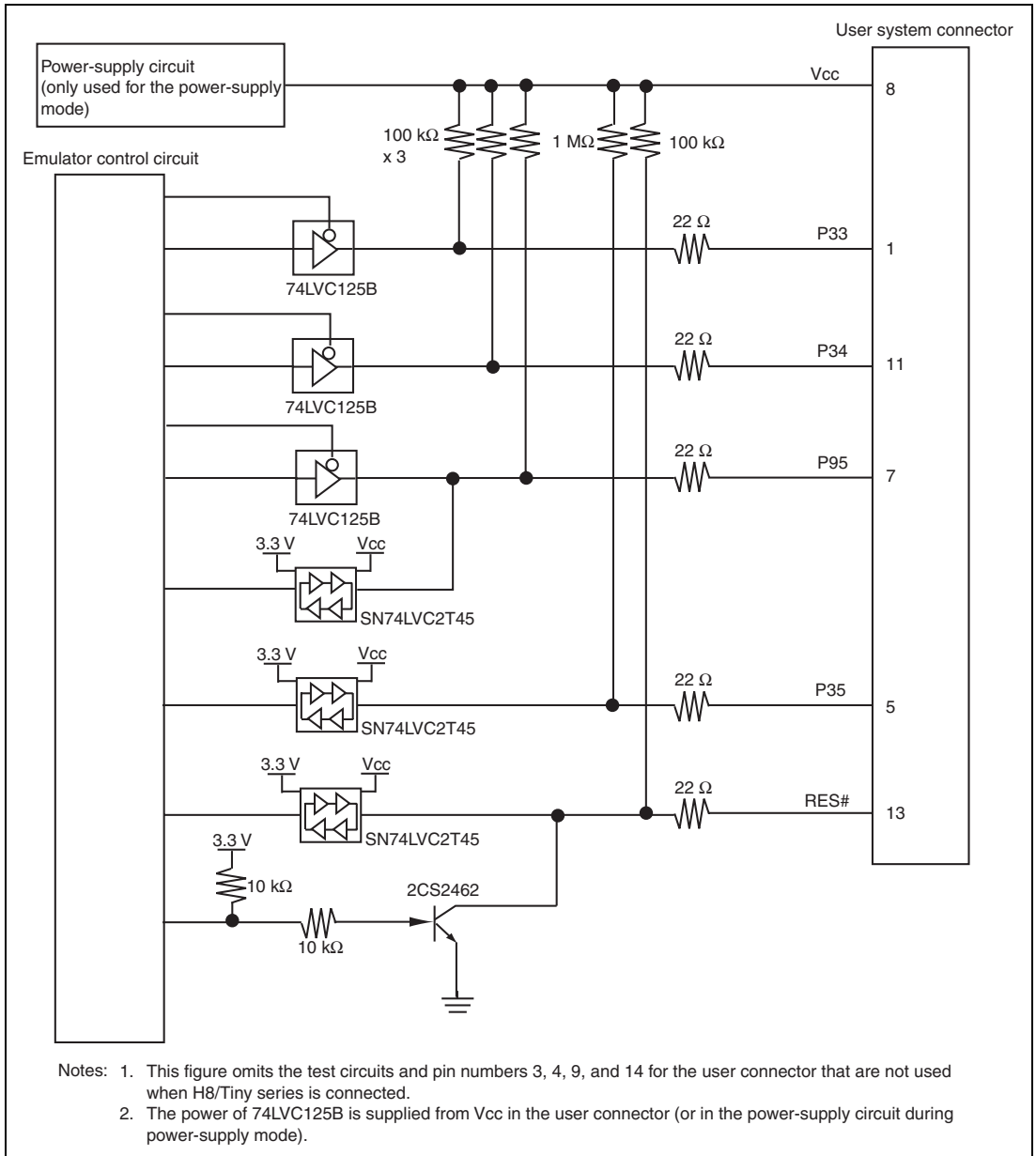

Figure 4.5 Interface Circuit in the E8a Emulator (Reference)

Section 5 Differences between the MCU (H8/38704F) and the Emulator

This section describes the differences between the emulator and MCU operations.

1. [Emulator Setting] Dialog Box

The [Emulator Setting] dialog box is provided for setting the items that need to be set when the emulator starts up (settings are saved in the session).

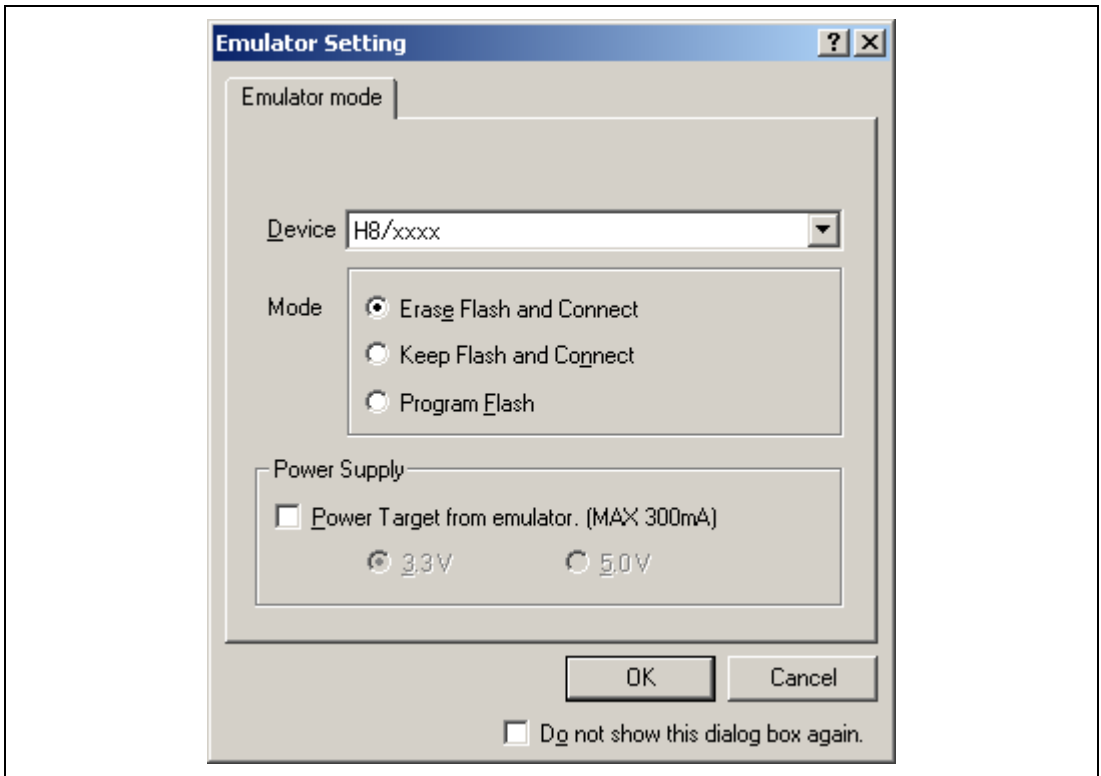

Figure 5.1 [Emulator Setting] Dialog Box

To keep the [Emulator Setting] dialog box closed next time the emulator is started, check "Do not show this dialog box again." at the bottom of the [Emulator Setting] dialog box. You can open the [Emulator Setting] dialog box using either one of the following methods:

- After the emulator gets started, select Menu - [Setup] -> [Emulator] -> [Emulator Setting...].
- Start the emulator while holding down the Ctrl key.
- After the emulator gets started and an error occurred, restart the emulator.

When you check "Do not show this dialog box again.", the emulator doesn't supply power to the user system. To use this check box, start the emulator after turning on the power.

2. Emulator Mode

The selection of the device, the specification of the mode, and the setting of the power supply are done in the [Emulator mode] page of the [Emulator Setting] dialog box.

— Device

Select the device name in use from the [Device] combo box. The following items are selected in the [Mode] group box.

— Modes

- Erase Flash and Connect

This mode is used when there is no emulator program in the flash memory of the target device. In this mode, data of the flash memory of the target device is erased when the emulator is activated. Select this item when the emulator is firstly activated, the version of the emulator's software is updated, or the ID code is changed.

- Keep Flash and Connect

This mode is used when there is an emulator program in the flash memory of the target device. Enter the ID code specified above ('Erase Flash and Connect'). If an incorrect code is entered, all the programs on the flash memory will be erased.

Note: When the emulator gets started in this mode after selecting "Do not show this dialog box again.", the initial value of the ID code is '0E8A'. If you use the ID code other than the initial value, do not use "Do not show this dialog box again."

- Program Flash

This mode is used when the emulator is used for programming the flash memory. Debugging the program is disabled. To download the load module, register it in the workspace.

Note: In the H8/Tiny or H8/Super Low Power device, the ID code is not entered in the Program Flash mode.

- Power Supply

When [Power Target from emulator. (MAX 300mA)] is checked, power will be supplied to the user system up to 300 mA. Then select 3.3 V or 5.0 V according to the power voltage of the user system.

3. Emulator Activation and ID Code

In the H8/Tiny- or H8/Super Low Power-series MCU, the [System Clock] and [ID Code] dialog boxes are set when the emulator is activated.

- Setting the system clock

Enter the clock value input to the board in use. The initial value differs in each MCU.

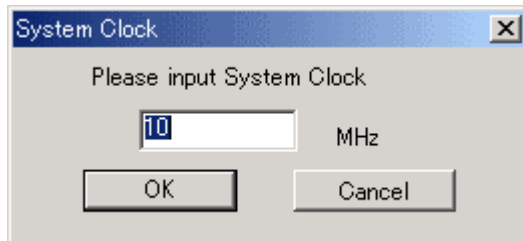

Figure 5.2 [System Clock] Dialog Box

- Setting the ID code

When the emulator is activated in the [Erase Flash and Connect] mode, enter any hexadecimal four-digit ID code to be set (except for H'FFFF). The initial value is H'0E8A. When the emulator is activated in the [Keep Flash and Connect] mode, enter the correct ID code. If an incorrect ID code is entered, all the contents of the flash memory will be erased. In this case, restart the emulator in the [Erase Flash and Connect] mode.

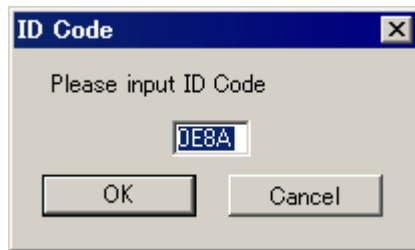

Figure 5.3 [ID Code] Dialog Box

4. When the emulator system is initiated, it initializes the general registers and part of the control registers as shown in table 5.1.

Table 5.1 Register Initial Values at Emulator Power-On

Register	Initial Value
PC	Reset vector value in the vector address table
ER0 to ER6	H'0000
ER7	H'FF80
CCR	H'80

5. Low-Power Mode

During a user program break, the CPU operating frequency is forced to a system clock (ϕ) for high-speed operation.

6. RES# Signal

The RES# signal is only valid during user program execution started with clicking the GO or STEP-type button. During a user program break, the RES# signal is not sent to the MCUs.

Note: Do not start user program execution or access the memory while control input signal (RES#) is being low. A TIMEOUT error will occur.

7. System Control Register

In the emulator, the internal I/O registers can be accessed from the [IO] window. However, be careful when accessing the system control register. The emulator saves the register value of the system control register at a break and returns the value when the user program is executed. Since this is done during a break, do not rewrite the system control register in the [IO] window.

8. Memory Access during Emulation

If the memory contents are referenced or modified during emulation, realtime emulation cannot be performed because the user program is temporarily halted.

9. The emulator communicates with the MCUs by using the RES#, P33 to P35, and P95 pins. These pins except for RES# cannot be used.

10. Sum Data Displayed in the Program Flash Mode

Sum data, which is displayed in the 'Program Flash' mode, is a value that data in the whole ROM areas has been added by byte (including data in the dedicated ROM area for the emulator).

11. Note on Executing the User Program

The set value is rewritten since the emulator uses flash memory and watchdog timer registers during programming (Go, Step In, Step Out, or Step Over) of the flash memory.

12. The power consumed by the MCU can reach several milliamperes. This is because the user power supply drives ICs to make the communication signal level match the user-system power-supply voltage. The power consumed rises little during user program execution since the emulator does not perform communication; it rises more during a break.

13. Program Area for the Emulator

Do not access a part of areas in the flash memory or the internal RAM since the emulator program uses these areas. If the contents of the program area for the emulator are changed, the emulator will not operate normally. In this case, restart the emulator with the Erase Flash and Connect mode.

Table 5.2 Program Area for the Emulator

MCU Name	Program Area
H8/38704F	Flash memory: H'7000 to H'7FFF Internal RAM: H'F780 to H'FB7F Vector, etc.: H'0002 to H'0007, H'0014 to H'0015, H'7FF8 to H'7FF9

14. The emulator uses a two-word stack pointer for values stored on a user program break. Therefore, the stack area must accept two-word addresses.

15. Do not use an MCU that has been used for debugging.

If the flash memory is rewritten many times, data may be lost due to retention problems after the emulator has been left for a few days and the data will be erased. If an error message is displayed, exchange the MCU for a new one.

16. Items Set in the [Configuration] Dialog Box

The emulator operation conditions are set in the [Configuration] dialog box.

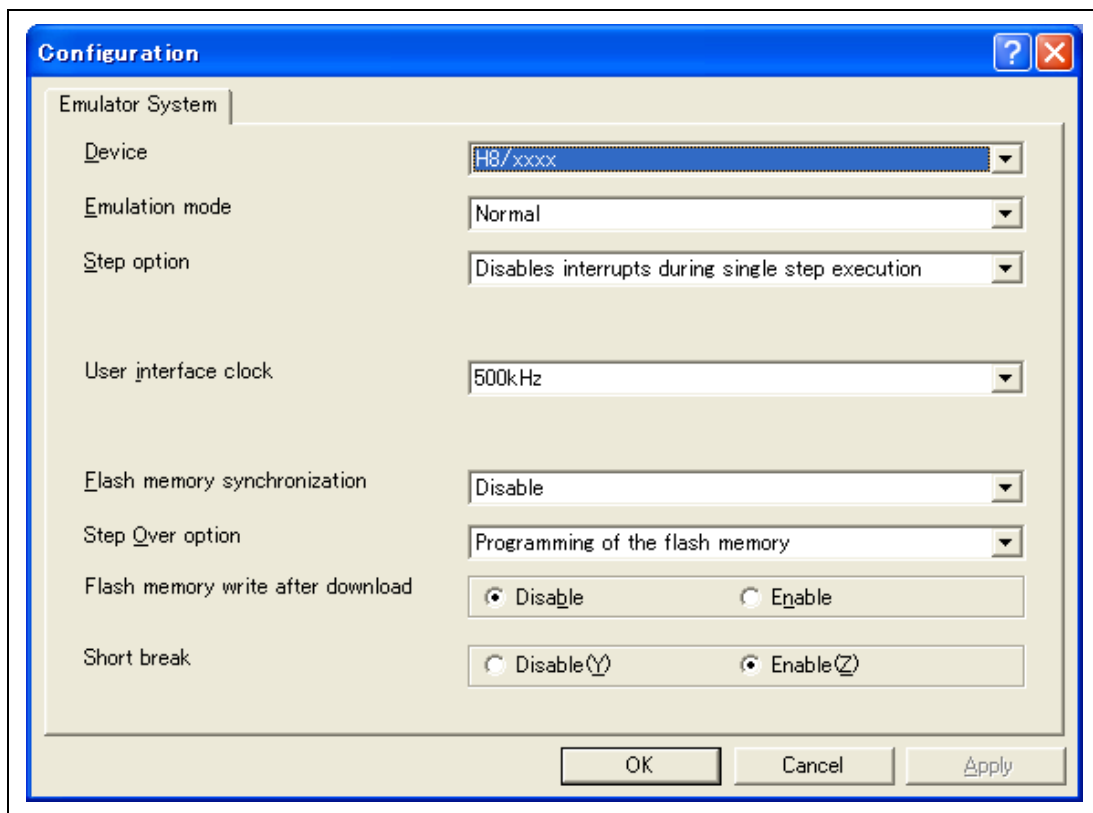

Figure 5.4 [Configuration] Dialog Box ([Emulator System] Page)

Items that can be displayed in this dialog box are listed below.

[Device] combo box	Displays the MCU name.
[Emulation mode] combo box	Selects the emulation mode at user program execution. Select Normal to perform normal emulation. Select No break to disable PC breakpoint or break condition settings during emulation.
[Step option] combo box	Sets the step interrupt option. Disable interrupts during single step execution: Disables interrupts ^{*1} during step execution. Enable interrupts during single step execution: Enables interrupts ^{*1} during step execution.
[User interface clock] combo box	Displays the transfer clock of the user interface.
[Flash memory synchronization] combo box	Selects whether or not the contents of the flash memory are acquired by the emulator when the user program is stopped or the position where the PC break is set is put back as the original code. When the flash memory is not programmed by the user program, its contents need not be acquired by the emulator.

If there is no problem with the state that the program in the flash memory has been replaced as the PC break code, the position where the PC break is set needs not be put back as the original code.

Disable: Read or program is not performed for the flash memory except when the emulator is activated, the flash memory area is modified, and the settings of the PC break to the flash memory area are changed.

PC to flash memory: When the user program is stopped, the specified PC break code is replaced as the original instruction. Select this option if there is a problem with the state that the program in the flash memory has been replaced as the PC break code.

Flash memory to PC: When the user program is stopped, the contents of the flash memory are read by the emulator. Select this option if the flash memory is reprogrammed by the user program.

PC to flash memory, Flash memory to PC:

When the user program is stopped, the contents of the flash memory are read by the emulator and the specified PC break code is replaced as the original instruction. Select this option if the flash memory is reprogrammed by the user program and there is a problem with the state that the program in the flash memory has been replaced as the PC break code.

[Step Over option] combo box

Enables or disables programming of the flash memory while executing step operation.

Programming of the flash memory: Uses a software break for step operation (e.g. Step Over) and enables programming of the flash memory.

No Programming of the flash memory: Uses Break Condition for step operation (e.g. Step Over) and disables programming of the flash memory^{*2}.

[Flash memory write after download] group box

Enables or disables programming of the flash memory after downloading the program.

Disable: Disables programming of the flash memory after downloading the program.

Enable: Enables programming of the flash memory after downloading the program.

[Short break] group box	<p>Enables or disables memory access during user program execution.</p> <p>Disable: Disables memory access during user program execution.</p> <p>Enable: Enables memory access during user program execution.</p>
-------------------------	---

Notes: 1. Includes interrupts in a break.

2. When Step Over is performed after selecting [No Programming of the flash memory] for [Step Over option], the instruction that follows a JSR, BSR, or TRAPA instruction will also be executed. If there are consecutive JSR, BSR, or TRAPA instructions, execution proceeds until it reaches an instruction that is not JSR, BSR, or TRAPA. (When there are consecutive function calls in C language, the program steps all of these functions.)

17. Initializing the Internal I/O Register with the Reset_CPU Function

Be sure to initialize the internal I/O registers shown below by the user program since they are not initialized by selecting [Debug] – [Reset CPU] or using the RESET command.

Table 5.3 Registers Not Initialized

MCU Name	Register Not Initialized
H8/38704F	SYSCR1, SYSCR2, IEGR, IENR2, IENR1, IRR1, IWPR, CKSTPR1, CKSTPR2

E8a Emulator

Additional Document for User's Manual

Notes on Connecting the H8/300H Super Low Power Series

Publication Date: Rev.1.00 August 3, 2009

Rev.3.00 March 14, 2012

Published by: Renesas Electronics Corporation



SALES OFFICES

Renesas Electronics Corporation

<http://www.renesas.com>

Refer to "http://www.renesas.com/" for the latest and detailed information.

Renesas Electronics America Inc.

2880 Scott Boulevard Santa Clara, CA 95050-2554, U.S.A.
Tel: +1-408-588-6000, Fax: +1-408-588-6130

Renesas Electronics Canada Limited

1101 Nicholson Road, Newmarket, Ontario L3Y 9C3, Canada
Tel: +1-905-898-5441, Fax: +1-905-898-3220

Renesas Electronics Europe Limited

Dukes Meadow, Millboard Road, Bourne End, Buckinghamshire, SL8 5FH, U.K.
Tel: +44-1628-585-100, Fax: +44-1628-585-900

Renesas Electronics Europe GmbH

Arcadiastrasse 10, 40472 Düsseldorf, Germany
Tel: +49-211-65030, Fax: +49-211-6503-1327

Renesas Electronics (China) Co., Ltd.

7th Floor, Quantum Plaza, No.27 ZhiChunLu Haidian District, Beijing 100083, P.R.China
Tel: +86-10-8235-1155, Fax: +86-10-8235-7679

Renesas Electronics (Shanghai) Co., Ltd.

Unit 204, 205, AZIA Center, No.1233 Lujiazui Ring Rd., Pudong District, Shanghai 200120, China
Tel: +86-21-5877-1818, Fax: +86-21-5887-7858 / -7898

Renesas Electronics Hong Kong Limited

Unit 1601-1613, 16/F., Tower 2, Grand Century Place, 193 Prince Edward Road West, Mongkok, Kowloon, Hong Kong
Tel: +852-2886-9318, Fax: +852-2886-9022/9044

Renesas Electronics Taiwan Co., Ltd.

13F, No. 363, Fu Shing North Road, Taipei, Taiwan
Tel: +886-2-8175-9600, Fax: +886-2-8175-9670

Renesas Electronics Singapore Pte. Ltd.

1 harbourFront Avenue, #06-10, Keppel Bay Tower, Singapore 098632
Tel: +65-6213-0200, Fax: +65-6278-8001

Renesas Electronics Malaysia Sdn.Bhd.

Unit 906, Block B, Menara Amcorp, Amcorp Trade Centre, No. 18, Jin Persiaran Barat, 46050 Petaling Jaya, Selangor Darul Ehsan, Malaysia
Tel: +60-3-7955-9390, Fax: +60-3-7955-9510

Renesas Electronics Korea Co., Ltd.

11F., Samik Laviel' or Bldg., 720-2 Yeoksam-Dong, Kangnam-Ku, Seoul 135-080, Korea
Tel: +82-2-558-3737, Fax: +82-2-558-5141

E8a Emulator
Additional Document for User's Manual
Notes on Connecting the H8/300H Super Low Power Series