

QCIOT-RRH46410POCZ

The RRH46410 is Renesas intelligent sensor module. The design encompasses the on-board microcontroller with integrated firmware, MEMS gas sensing element, and CMOS signal conditioning IC in one package. Examples of available support for RRH46410 are the evaluation kit hardware/software, application notes, white papers, and examples codes. For faster development, Renesas offers the RRH46410 sensor module in popular form factor Pmod™ board. Using the e2 studio IDE and RRH46410 Flexible Support Package (FSP), the method of adding the sensor into the project is simplified. The IDE software features a code generation tool providing an excellent starting point for code development.

The QCIOT-RRH46410POCZ board provides a standard Pmod Type 6A (Extended I²C) connection for the on-board sensor to plug into any MCU evaluation kit with a matching connector. The QCIOT-RRH46410POCZ features Pmod connectors on both sides of the board allowing additional Type 6/6A boards to be connected in a daisy-chained solution with multiple sensors on the same MCU Pmod connector. With its standard connector and software support, the QCIOT-RRH46410POCZ is ideal for rapidly creating an IoT system using the Renesas Quick-Connect IoT tools.

Features

- Sensor output based on AI machine learning algorithm:
 - Absolute measurement of total organic compounds (TVOC) concentrations and indoor air quality (IAQ)
 - Absolute TVOC output to meet Public Building Air Quality (PBAQ) standards
 - Relative IAQ based on TVOC and odor changes
 - Estimated carbon dioxide level (eCO₂)
- Ultra-low power consumption down to 226μW
- Siloxane resistant
- JEDEC JESD47 qualified for 10 years time-of-life
- Supply voltage: 1.8V to 3.3V
- Programmable GPIO pins
- Operating temperature: -40°C to +65°C
- IP67 rating
- Package: 4.5 × 4.0 × 0.950 mm body, 0.50 pitch 20-LGA
- Support I²C and UART

Kit Contents

- QCIOT-RRH46410POCZ Board



Figure 1. QCIOT-RRH46410POCZ Pmod Board

Contents

1. Functional Description	3
1.1 Setup and Configuration	3
1.1.1 Software Installation and Usage	3
1.1.2 Software Setup	3
1.1.3 Programming Interface	3
1.1.4 Kit Hardware Connections	5
2. Board Design	6
2.1 Application Schematic Diagram	6
2.2 Bill of Materials	7
2.3 Board Layout	7
3. Ordering Information	8
4. Revision History	8

1. Functional Description

The QCIOT-RTC22MPOCZ board functions as a sensor building block enabling the designer to create a fast prototyping custom system solution. Use the board individually or with a combination of other sensor boards by using the Pmod Type 6A interface. For a list of available sensor Pmod boards, visit the Renesas [Quick-Connect IoT](#) web page.

1.1 Setup and Configuration

The following additional lab equipment is required for using the board (and is sold separately):

- Any MCU board that supports Type 6A Pmod
- US082-INTERPEVZ interposer board (see [Table 1](#))

1.1.1 Software Installation and Usage

For more information on creating a full system design, further information on software development, and additional hardware availability, visit the Renesas website for the latest version of the e2 studio [installer](#). The minimum FSP version supporting the RRH46410 sensor block is FSP 5.3.0. For the latest sensor support, ensure that the latest release is used.

Visit the Renesas [Quick-Connect IoT](#) site for more information about creating your customized system solution.

1.1.2 Software Setup

The [US082-INTERPEVZ](#) interposer board is required when using one of the Renesas MCU kits listed in [Table 1](#).

Table 1. MCU Kits^[1] Capable of Supporting Type 6A Pmod Boards When Used with US082-INTERPEVZ

RA	RX	Synergy
EK-RA4W1 Evaluation Kit	RSK-RX111 Starter Kit	PK-S5D9 Promotion Kit
EK-RA2A1 Evaluation Kit	RSK-RX231 Starter Kit	DK-S3A7 Development Kit
EK-RA4M1 Evaluation Kit	RSK-RX23W Starter Kit	DK-S128 Development Kit
EK-RA6M1 Evaluation Kit	RSK-RX23T Starter Kit	TB-S1JA Target Board
EK-RA6M2 Evaluation Kit	RSK-RX24T Starter Kit	TB-S3A6 Target Board
EK-RA6M3 Evaluation Kit	RSK-RX24U Starter Kit	DK-S7G2 Development Kit
EK-RA6M3G Evaluation Kit	-	-

1. This table is not a comprehensive list of supported MCU Kits. See the evaluation kit hardware manual to confirm Pmod pinout.

1.1.3 Programming Interface

Programming of the system is accomplished through the Renesas IDE [e2 studio](#). See the MCU evaluation kit documentation to setup the initial project in e2 studio. Add the RRH46410 sensor during project initialization with the following steps:

1. From the Project Explorer tab, locate and open the **script** folder and double-click on **configuration.xml**.
2. Open the FSP Configuration view/file.
3. Add the following stack element by clicking the *New Stack* button and editing the configuration values for desired operation (see [Figure 2](#)).
4. Select **RRH46410 Gas Sensor Module (rm_rrh46410)**.
5. Click the *Generate Project Content* icon and the system will generate the code for the MCU to communicate to the RRH Pmod board.

6. Sample calls displaying the functions to open the sensors are shown in [Figure 3](#). Similar calls are required for the I²C bus. Utilize the data given in your application. For additional information, refer to the manual related to FSP configuration and function APIs.

Note: Renesas recommends downloading and reviewing sample projects that are available on the Renesas website.

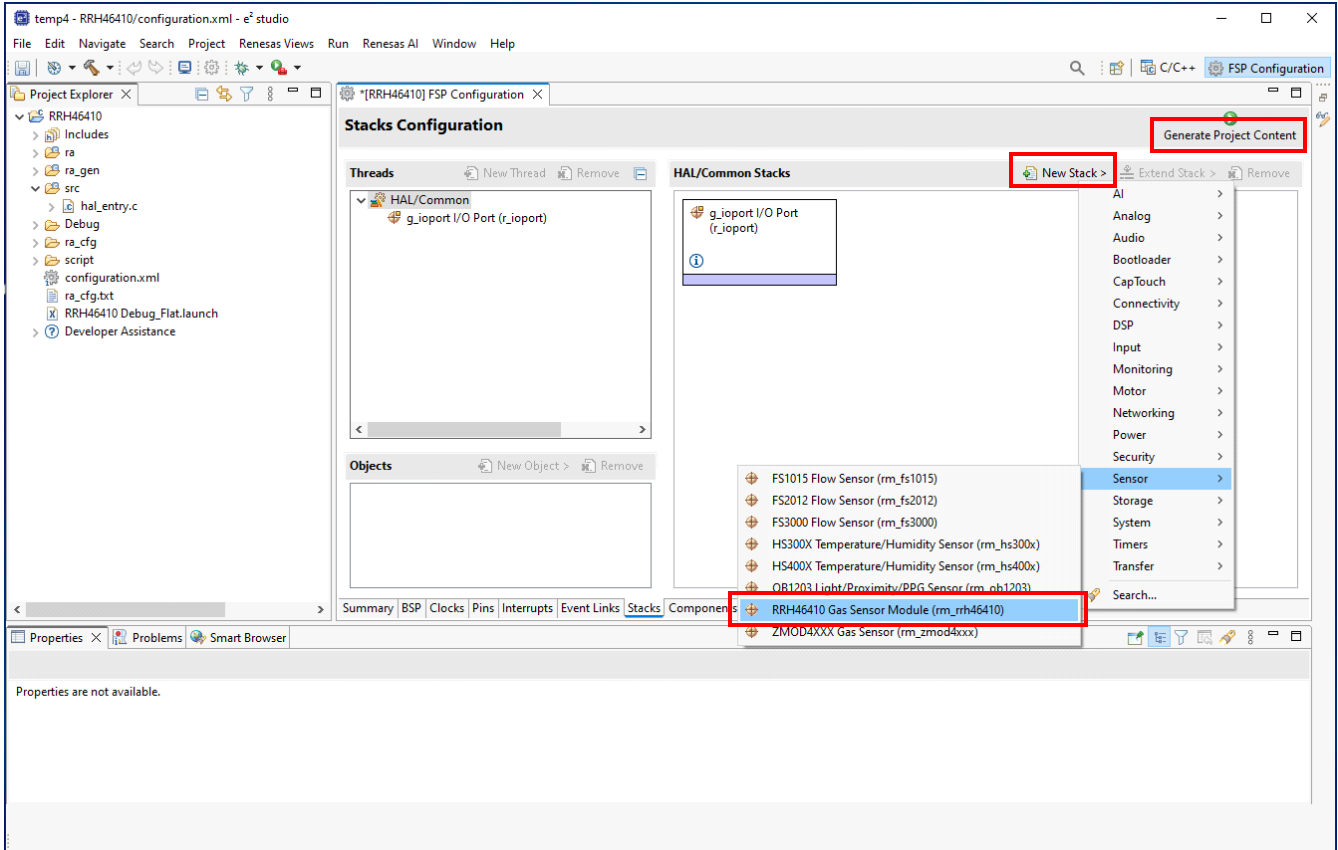

Figure 2. Stacks Configuration Window

```

/* Quick setup for g_rrh46410_sensor0.
 * - i2c_bus_name must be setup before calling this function
 *   (See Developer Assistance -> g_rrh46410_sensor0 -> RRH46410 ***** on rm_rrh46410 -> g_comms_i2c_device0 -> i2c_bus_name -> Quick Setup).
 */
void g_rrh46410_sensor0_quick_setup(void);

/* Quick setup for g_rrh46410_sensor0. */
void g_rrh46410_sensor0_quick_setup(void)
{
    fsp_err_t err;

    /* Open RRH46410 sensor instance, this must be done before calling any RRH46410 API */
    err = RM_RRH46410_Open(&g_rrh46410_sensor0_ctrl, &g_rrh46410_sensor0_cfg);
    assert(FSP_SUCCESS == err);

    /* Clear the flag */
    g_rrh46410_measurement_start = false;
}

```

Figure 3. Example Code to Start the Sensor after FSP Configuration

1.1.4 Kit Hardware Connections

Follow these procedures to set up the kit as shown in [Figure 4](#).

1. Ensure the MCU evaluation kit being used has a Pmod connector set to Type 6A (refer to the kit's hardware manual for settings).
 - a. If a Type 6A Pmod is unavailable, ensure the MCU evaluation kit can use the US082-INTERPEVZ interposer board. Insert the interposer board into the MCU connector before adding any sensor boards.
2. Plug in the QCIOT-RRH46410POCZ board to the Type 6A connector. Care must be taken when aligning Pin 1 on the MCU connector.
3. Connect the J4 and J5 jumpers to place 4.7k pull-up resistors on the I²C bus lines.
 - a. Only one set of pull-up resistors should be used on the I²C bus lines. If multiple sensor boards are used, only one board should have the jumpers present.
 - b. MCU kits typically do not have pull-up resistors present on these lines, however, ensure to check and verify if resistors are present.
4. Connect the J3 jumper to place 4.7k pull-up resistors on the Pmod INT# line.
 - a. Only one pull-up resistor should be used on the Pmod INT# line. If multiple sensor boards using the INT# signal are used, only one board should have the jumpers present.

The sensor is now set up and ready to be used in the system. Follow the MCU kit instructions for connecting and powering up the evaluation kit.

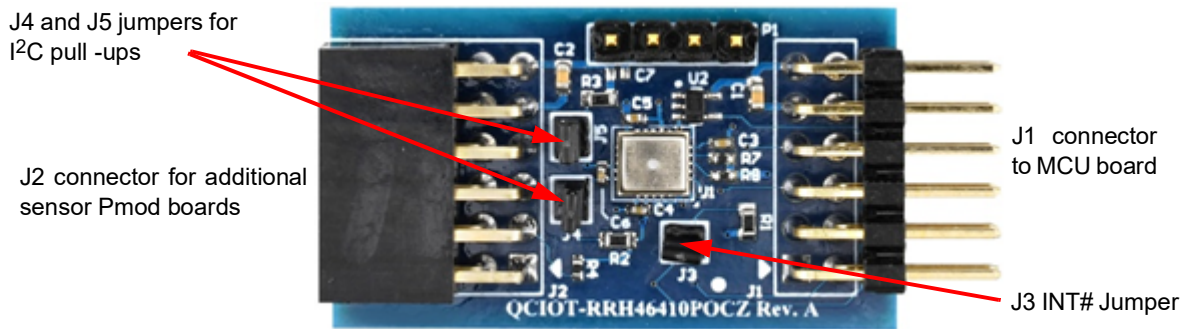

Figure 4. QCIOT-RTC22MPOCZ Board Connections

2. Board Design

2.1 Application Schematic Diagram

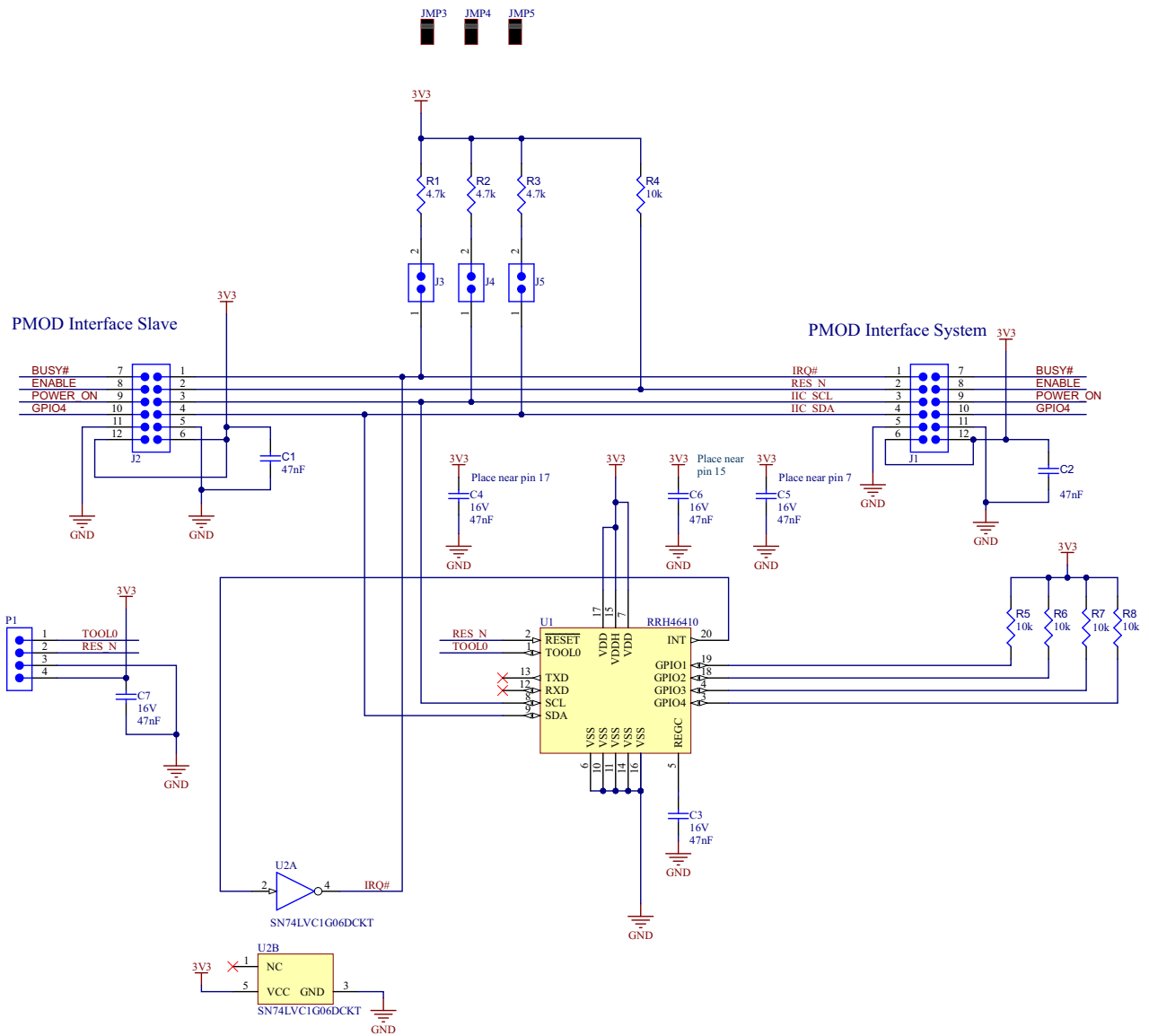

Figure 5. QCIOT-RRH46410MPOCZ Application Schematic

2.2 Bill of Materials

Qty	Reference Designator	Description	Manufacturer	Part Number
2	C1, C2	Ceramic Capacitor, Multilayer, Ceramic, 50V, 10% +Tol, 10% -Tol, X7R, 15% TC, 0.047uF, Surface Mount, 0603	Kyocera AVX	06035C473KAZ2A
4	C3, C4, C5, C6	Ceramic Chip Capacitor 0402 47nF 16V	Samsung	CL05B473KO5NNNC
1	FOOT1	Foot, Rubber, Self-adhesive, Black, 6.4mm diameter, 2.1mm tall	Bumper Specialties	BS25BL07X30RP
1	J1	Male Header 0.1" pitch PMOD 2 × 6 Right Angle	Wurth Elektronik	61301221021
1	J2	Female Header 0.1" pitch PMOD 2 × 6 Right Angle	Wurth Electronics	613012243121
3	J3, J4, J5	Conn Header Vert 2Pos 1.27mm	Samtec	FTS-102-01-L-S
3	JMP3, JMP4, JMP5	2 C, Closed Top, .050" CC; No Mounting, 105 C, Nylon 66; Phos Bronze, Gold Flash	Sullins	NPB02SVFN-RC
3	R1, R2, R3	Chip Resistor, 4.7kOhm, ±1%, 0.1W, -55 to +155 °C, 0603 (1608 Metric)	Yageo	RC0603FR-134K7L
1	R4	Chip Resistor, 10kOhm, ±1%, 63mW, -55 to +155 °C, 0402 (1005 Metric)	Panasonic	RC0402FR-0710KL
4	R5, R6, R7, R8	Chip Resistor, 10kOhm, ±1%, 0.1W, -55 to +155 °C, 0402 (1005 Metric)	Sullins	ERJ-2RKF1002X
1	U1	RRH46410 Integrated Air Quality Sensor, I2C and UART Interface.	Renesas	RRH46410-A3R
1	U2	Single Inverter Buffer/Driver With Open-Drain Output, DCK0005A, Small T&R	Texas Instrument	SN74LVC1G06DCKT

2.3 Board Layout

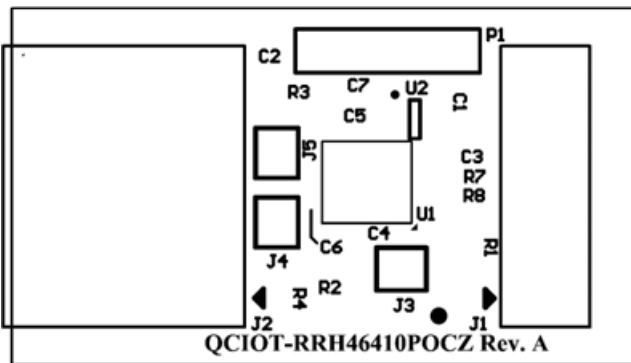

Figure 6. Silkscreen Top

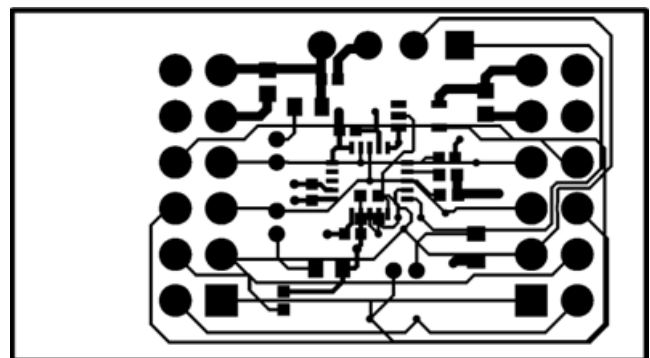

Figure 7. Copper Top

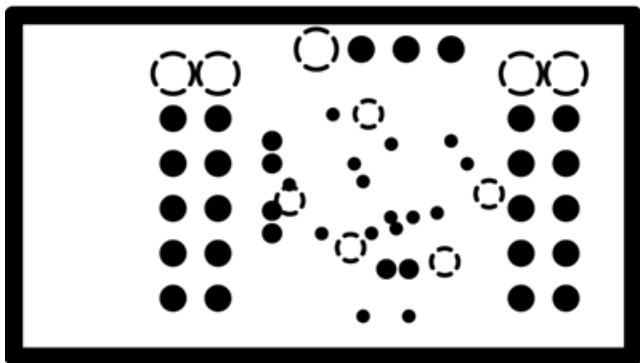

Figure 8. Copper L1 Layer

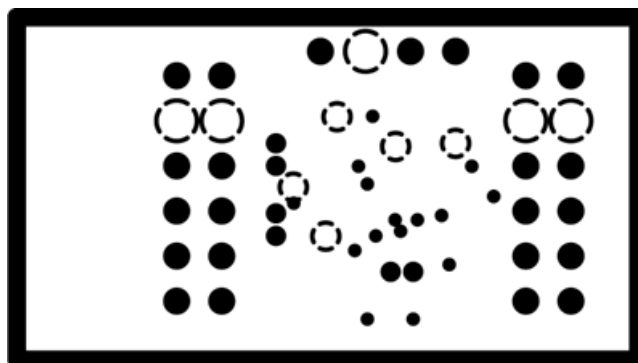

Figure 9. Copper L2 Layer

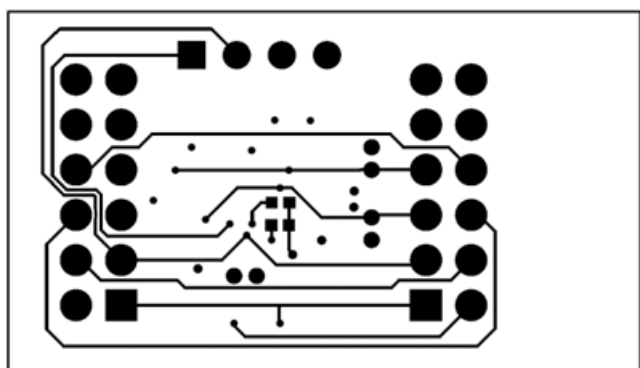

Figure 10. Copper Bottom

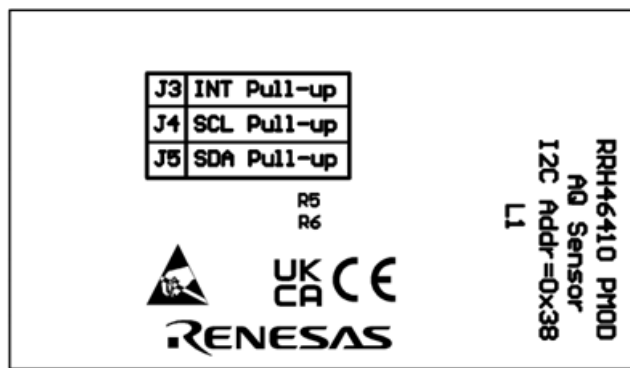

Figure 11. Silkscreen Bottom

3. Ordering Information

Part Number	Description
QCIOT-RRH46410POCZ	RRH46410 Pmod Board
US082-INTERPEVZ	Pmod interposer board to convert Type 2A and 3A to Type 6A on older Renesas MCU kits.

4. Revision History

Revision	Date	Description
1.00	Jul 17, 2024	Initial release.

IMPORTANT NOTICE AND DISCLAIMER

RENESAS ELECTRONICS CORPORATION AND ITS SUBSIDIARIES (“RENESAS”) PROVIDES TECHNICAL SPECIFICATIONS AND RELIABILITY DATA (INCLUDING DATASHEETS), DESIGN RESOURCES (INCLUDING REFERENCE DESIGNS), APPLICATION OR OTHER DESIGN ADVICE, WEB TOOLS, SAFETY INFORMATION, AND OTHER RESOURCES “AS IS” AND WITH ALL FAULTS, AND DISCLAIMS ALL WARRANTIES, EXPRESS OR IMPLIED, INCLUDING, WITHOUT LIMITATION, ANY IMPLIED WARRANTIES OF MERCHANTABILITY, FITNESS FOR A PARTICULAR PURPOSE, OR NON-INFRINGEMENT OF THIRD-PARTY INTELLECTUAL PROPERTY RIGHTS.

These resources are intended for developers who are designing with Renesas products. You are solely responsible for (1) selecting the appropriate products for your application, (2) designing, validating, and testing your application, and (3) ensuring your application meets applicable standards, and any other safety, security, or other requirements. These resources are subject to change without notice. Renesas grants you permission to use these resources only to develop an application that uses Renesas products. Other reproduction or use of these resources is strictly prohibited. No license is granted to any other Renesas intellectual property or to any third-party intellectual property. Renesas disclaims responsibility for, and you will fully indemnify Renesas and its representatives against, any claims, damages, costs, losses, or liabilities arising from your use of these resources. Renesas' products are provided only subject to Renesas' Terms and Conditions of Sale or other applicable terms agreed to in writing. No use of any Renesas resources expands or otherwise alters any applicable warranties or warranty disclaimers for these products.

(Disclaimer Rev.1.01 Jan 2024)

Corporate Headquarters

TOYOSU FORESIA, 3-2-24 Toyosu,
Koto-ku, Tokyo 135-0061, Japan
www.renesas.com

Trademarks

Renesas and the Renesas logo are trademarks of Renesas Electronics Corporation. All trademarks and registered trademarks are the property of their respective owners.

Contact Information

For further information on a product, technology, the most up-to-date version of a document, or your nearest sales office, please visit www.renesas.com/contact-us/.