

Measure it! RL78/I1B

The Off-the-shelf Energy Monitoring Solution



Renesas Electronics' RL78/I1B microcontroller family delivers a genuine single-chip solution for electricity measurements in applications such as single or multi-load energy monitoring. The software defined metrology architecture offers a highly flexible methodology that can be adapted to many varied industrial and consumer applications both within and outside of the traditional 50/60 Hz power measurement arena, whilst high accuracy and a wide range of peripherals, including segment LCD direct drive and flexible serial communications, make the RL78/I1B family an ideal fit for any non-billing single-phase application.

The Measure it! RL78 energy monitor kit comes complete with a suite of tools including the e2studio IDE and software, and a Windows™ GUI for logging and visualization of the energy use on single phases, frequency, etc. The energy monitor evaluation platform features two outlets that allow independent performance tests to be conducted on two loads simultaneously.

Target Applications

- Industrial metering
- Sub-Metering
- Smart plugs
- Appliance monitoring
- Power Distribution Units
- UPS and Stored Energy systems

RL78 Measure it! Kit and SW Screenshots

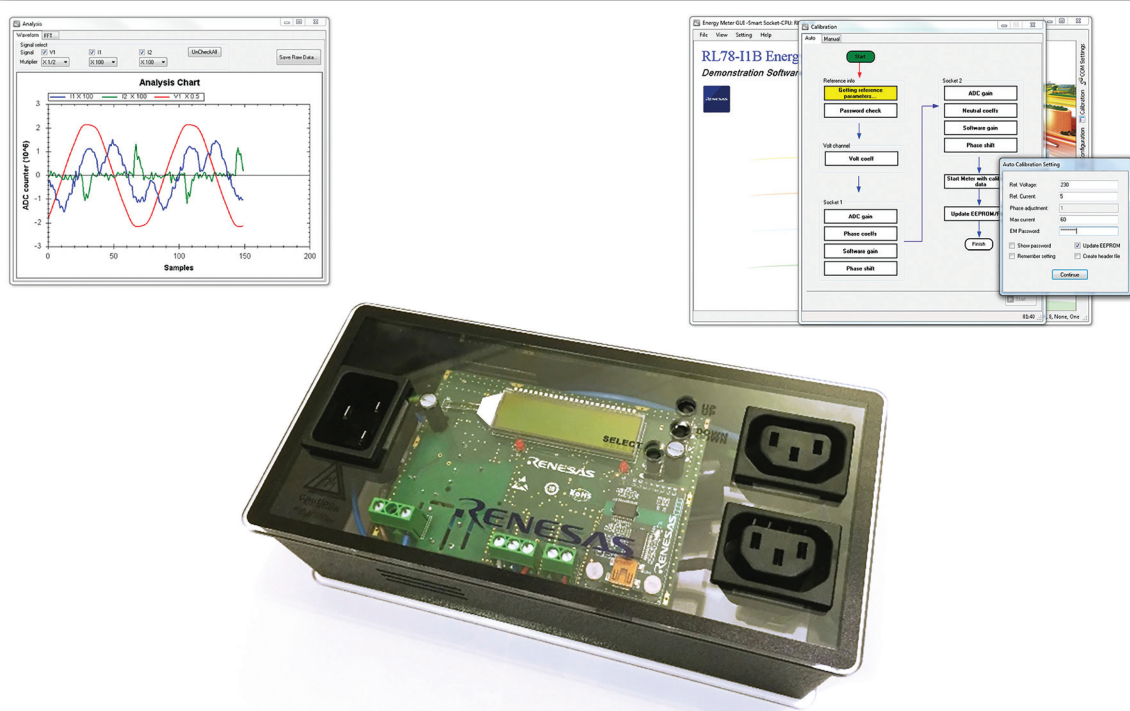

Block Diagram

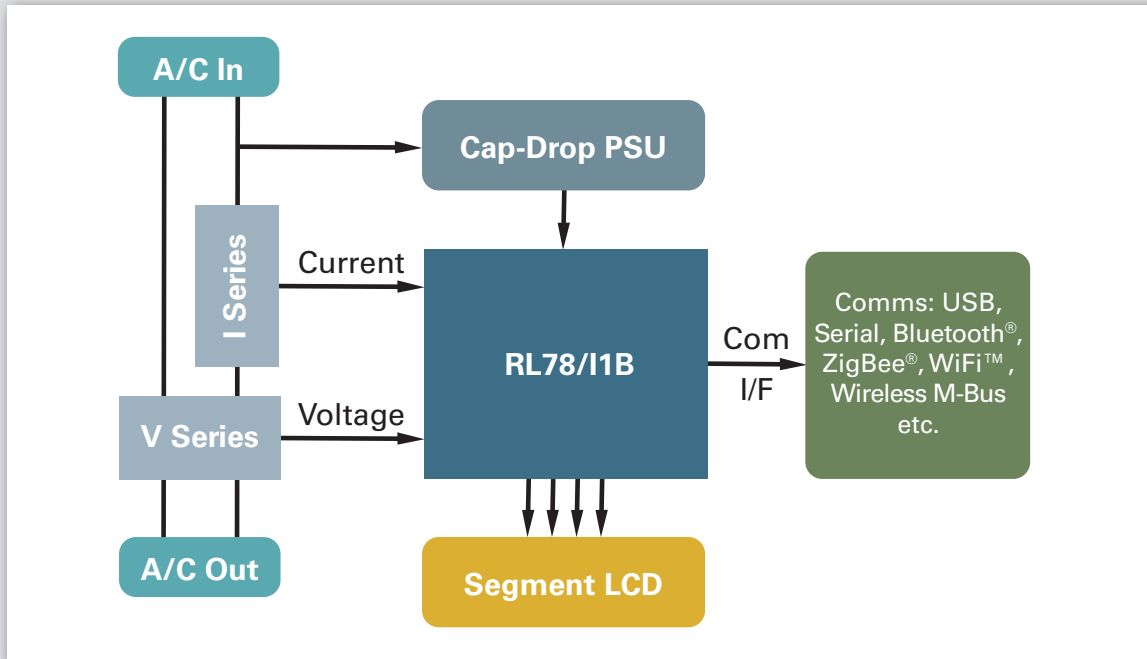

Solution key strengths

| Key Features | Key Benefits |
|---|--|
| Single chip solution | Higher reliability and total cost saving |
| Tested metrology software available in source code | Ready tested metrology software allows fast time to market |
| Multi outlet monitoring with independent data recording | Monitors up to two independent loads with one chip |
| CT and shunt support | Highly flexible system |
| Single point calibration routine embedded | Allows fast factory calibration |
| Windows™ GUI with logging and visualization of the energy use on single phases, frequency, etc. | Ready-to-use platform for visualizing the energy consumption |

Reference design with

- Single phase power monitor design
- User's manual
- Complete metrology software
- Schematics and Gerber files
- Single point calibration methodology embedded
- Windows™ GUI, allows to visualize and log meter feedback, connects via isolated USB port on the meter to the PC

Ordering Information

- YMEASURE-IT-RL78

Before purchasing or using any Renesas Electronics products listed herein, please refer to the latest product manual and/or data sheet in advance.

