

Brief Description

The ZSSC3018 is a sensor signal conditioner (SSC) integrated circuit for high-accuracy amplification and analog-to-digital conversion of differential or pseudo-differential input signals. Designed for high-resolution sensor module applications, the ZSSC3018 can perform offset, span, and 1st and 2nd order temperature compensation of the measured signal. Developed for correction of resistive bridge or absolute voltage sensors, it can also provide a corrected temperature output measured with an internal sensor.

The measured and corrected sensor values are provided at the digital output pins, which can be configured as I²C ($\leq 3.4\text{MHz}$) or SPI ($\leq 10\text{MHz}$). Digital compensation of signal offset, sensitivity, temperature, and non-linearity is accomplished via a 26-bit internal digital signal processor (DSP) running a correction algorithm. Calibration coefficients are stored on-chip in a highly reliable, non-volatile, multiple-time programmable (MTP) memory. Programming the ZSSC3018 is simple via the serial interface. The interface is used for the PC-controlled calibration procedure, which programs the set of calibration coefficients in memory. The ZSSC3018 provides accelerated signal processing, increased resolution, and improved noise immunity in order to support high-speed control, safety, and real-time sensing applications with the highest requirements for energy efficiency.

Features

- Flexible, programmable analog front-end design; up to 18-bit analog-to-digital converter (ADC)
- Fully programmable gain amplifier with gain range from 6.6 to 216 (linear)
- Internal auto-compensated temperature sensor
- Digital compensation of individual sensor offset; 1st and 2nd order digital compensation of sensor gain as well as of 1st and 2nd order temperature gain and offset drift
- Programmable interrupt operation
- High-speed sensing: e.g., 16-bit conditioned sensor signal measurement rate $>500\text{s}^{-1}$
- Typical sensor system can achieve an accuracy of better than $\pm 0.10\% \text{ FSO}^* @ -40 \text{ to } 125^\circ\text{C}$

Benefits

- Integrated 26-bit calibration math DSP
- Fully corrected signal at digital output
- Layout customized for die-die bonding with sensor for high-density chip-on-board assembly
- One-pass calibration minimizes calibration costs
- No external trimming, filter, or buffering components required
- Highly integrated CMOS design
- Integrated reprogrammable non-volatile memory
- Excellent for low-voltage and low-power battery applications
- Optimized for operation in calibrated resistive sensor (e.g., pressure) or calibrated absolute voltage sensor (e.g., thermopile) modules

Physical Characteristics

- Supply voltage range: 1.68V to 3.6V
- Current consumption: $\sim 1.0\text{mA}$ (typical) in operating mode
- Sleep Mode current: 50nA (typical) at $\leq 125^\circ\text{C}$; 20nA (typical) at $\leq 85^\circ\text{C}$
- Temperature resolution: $< 0.003\text{K/LSB}$
- Best-in-class energy-efficiency:
 - with 16-bit resolution: $< 140\text{pJ/step}$
 - with 18-bit resolution: $< 50\text{pJ/step}$
- Operation temperature: -40°C to $+125^\circ\text{C}$
- Delivery options: die or 24-PQFN (4 x 4 mm) package

* FSO = Full Scale Output.

ZSSC3018 Application Example

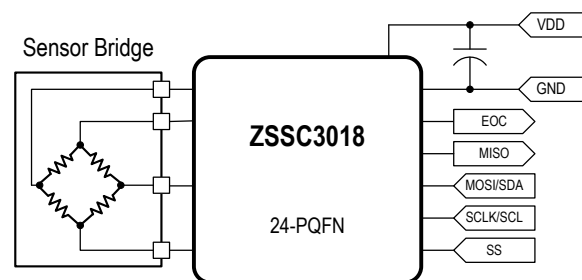

Block Diagram

(Bridge Sensor Example)

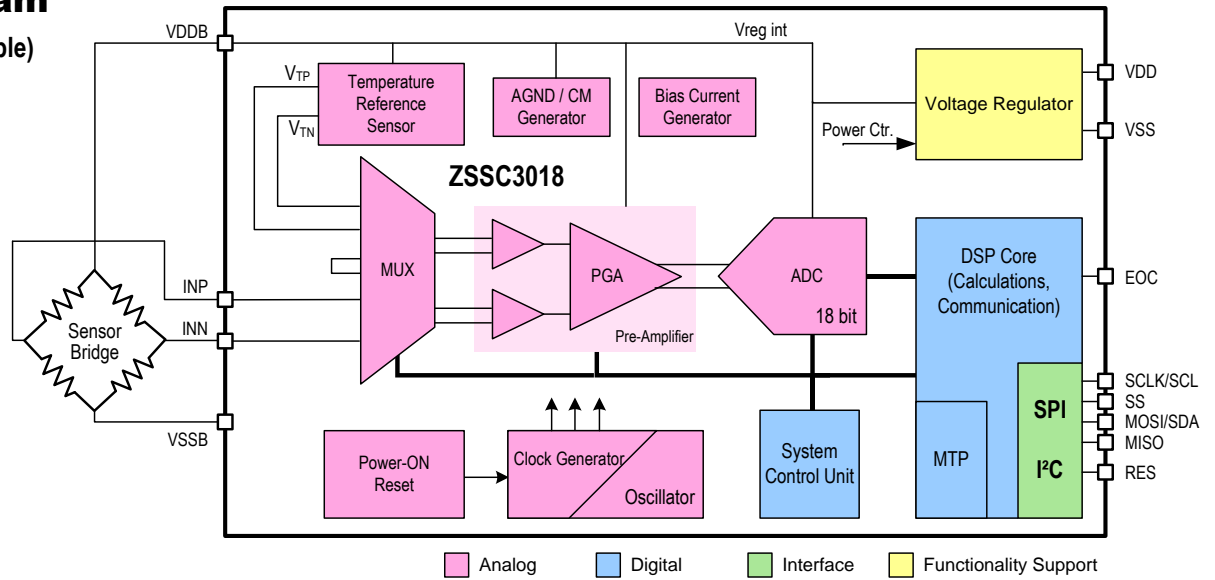

Applications

- Barometric altitude measurement for portable navigation or emergency call systems
- Altitude measurement for car navigation
- Weather forecast
- Fan control
- Industrial, pneumatic, and liquid pressure
- High-resolution temperature measurements
- Object-temperature radiation (via thermopile)

Table of Contents

1.	IC Characteristics	6
1.1	Absolute Maximum Ratings	6
1.2	Operating Conditions	6
1.3	Electrical Parameters	7
1.4	Power Supply Rejection Ratio (RSRR) versus Frequency	9
2.	Circuit Description	10
2.1	Brief Description	10
2.2	Signal Flow and Block Diagram	10
2.3	Analog Front End	12
2.3.1	Amplifier	12
2.3.2	Analog-to-Digital Converter	13
2.3.3	Selection of Gain and Offset – Sensor System Dimensioning	15
2.3.4	Temperature Measurement	16
2.3.5	External Sensor Supply: Bridge Sensors	16
2.3.6	External Sensor: Absolute Voltage Source Sensors	16
2.4	Digital Section	17
2.4.1	Digital Signal Processor (DSP) Core	17
2.4.2	MTP Memory	17
2.4.3	Clock Generator	17
2.4.4	Power Supervision	17
2.4.5	Interface	17
3.	Functional Description	18
3.1	Power-Up	18
3.2	Measurements	18
3.3	Interrupt (EOC Pin)	18
3.4	Operational Modes	20
3.4.1	SPI/I ² C Commands	23
3.5	Communication Interface	26
3.5.1	Common Functionality	26
3.5.2	SPI	27
3.5.3	I ² C	29
3.6	Memory	30
3.6.1	Programming Memory	30
3.6.2	Memory Contents	31
3.7	Calibration Sequence	39
3.7.1	Calibration Step 1 – Assigning Unique Identification	39
3.7.2	Calibration Step 2 – Data Collection	39
3.7.3	Calibration Step 3a) – Coefficient Calculations	40

3.7.4	Calibration Step 3b) – Post-Calibration Offset Correction	40
3.7.5	SSC Measurements	41
3.8	The Calibration Math	42
3.8.1	Bridge Signal Compensation	42
3.8.2	Temperature Signal Compensation	44
3.8.3	Measurement Output Data Format	45
4.	Packaging Dimensions and Pin Assignments	46
5.	Quality and Reliability	48
6.	Ordering Information	48
7.	Related Documents	48
8.	Glossary	48
9.	Revision History	50

Table of Figures

Figure 2.1	ZSSC3018 Functional Block Diagram, Resistive-Bridge-Sensor	10
Figure 2.2	ZSSC3018 Functional Block Diagram, Voltage-Source-Sensor	11
Figure 2.3	ADC Gain and Offset Setup	16
Figure 3.1	Interrupt Functionality: INT_setup = 01 and INT_setup = 10	19
Figure 3.2	Interrupt Functionality: INT_setup = 11	20
Figure 3.3	Operational Flow Chart: Power Up	21
Figure 3.4	Operational Flow Chart: Command Mode and Normal Mode (Sleep and Cyclic)	22
Figure 3.5	SPI Configuration CPHA=0	27
Figure 3.6	SPI Configuration CPHA=1	27
Figure 3.7	SPI Command Request	28
Figure 3.8	SPI Read Status	28
Figure 3.9	SPI Read Data	28
Figure 3.10	I ² C Command Request	29
Figure 3.11	I ² C Read Status	29
Figure 3.12	I ² C Read Data	30

List of Tables

Table 1.1 Absolute Maximum Ratings6

Table 1.2 Operating Conditions6

Table 1.3 Requirements for VDD Power-on Reset (POR)7

Table 1.4 Electrical Parameters7

Table 2.1 Amplifier Gain: Stage 112

Table 2.2 Amplifier Gain: Stage 212

Table 2.3 Gain Polarity13

Table 2.4 ADC Conversion Times for a Single A2D Conversion13

Table 2.5 ADC Offset Shift14

Table 2.6 Typical Conversion Times versus Noise Performance with Full Sensor Signal Conditioning for Measurement Including AZSM, SM, AZTM, and TM (Bridge-Type Sensor)14

Table 3.1 SPI/I²C Commands23

Table 3.2 Get_Raw Commands25

Table 3.3 General Status Byte26

Table 3.4 Mode Status26

Table 3.5 MTP Memory Content Assignments31

Table 3.6 Measurement Results of ADC Raw Measurement Request (Two's Complement)45

Table 3.7 Calibration Coefficients (Factors and Summands) in Memory (Sign-Magnitude)45

Table 3.8 Output Results from SSC-Correction Math or DSP—Sensor and Temperature45

Table 3.9 Interrupt Thresholds TRSH1 and TRSH2—Format as for SSC-Correction Math Output45

Table 4.1 24-PQFN Dimensions (4 x 4 mm)46

Table 4.2 Pin Assignments 24-PQFN47

1. IC Characteristics

1.1 Absolute Maximum Ratings

Note: The absolute maximum ratings are stress ratings only. The ZSSC3018 might not function or be operable above the recommended operating conditions. Stresses exceeding the absolute maximum ratings might also damage the device. In addition, extended exposure to stresses above the recommended operating conditions might affect device reliability. Renesas does not recommend designing to the "Absolute Maximum Ratings."

Table 1.1 Absolute Maximum Ratings

PARAMETER	SYMBOL	Min	TYP	MAX	UNITS
Voltage Reference	V _{SS}	0	–	0	V
Analog Supply Voltage	V _{DD}	-0.4	–	3.63	V
Voltage at all Analog and Digital IO Pins	V _{A_IO} , V _{D_IO}	-0.5	–	V _{DD} +0.5	V
Input Current into any Pin except RES, TEST1, TEST2, TEST3, TEST4, TEST5, and SS [a], [b]	I _{IN}	-100	–	100	mA
Electrostatic Discharge Tolerance – Human Body Model (HBM1) [c]	V _{HBM1}	4000	–	–	V
Storage Temperature	T _{STOR}	-50	–	130	°C

[a] Latch-up current limit for RES, TEST1, TEST2, TEST3, TEST4, TEST5, and SS: ±70mA.

[b] Latch-up resistance; reference for pin is 0V.

[c] HBM1: C = 100pF charged to V_{HBM1} with resistor R = 1.5kΩ in series based on MIL 883, Method 3015.7. ESD protection referring to the Human Body Model is tested with devices in ceramic dual in-line packages (CDIP) during product qualification.

1.2 Operating Conditions

Note: The reference for all voltages is V_{SS}.

Table 1.2 Operating Conditions

PARAMETER	SYMBOL	MIN	TYP	MAX	UNIT
Supply Voltage	V _{DD}	1.68	–	3.6	V
VDD Rise Time	t _{VDD}	–	–	200	μs
Bridge Current [a]	I _{VDD}	–	–	1.8	mA
		–	–	16.5	
Operation Temperature Range	T _{AMB}	-40	–	125	°C
External (Parasitic) Capacitance between VDD and VSS	C _L	0.01	–	50	nF

[a] Power supply rejection is reduced if a current in the range of 16.5mA > I_{VDD} > 1.8mA is drawn out of VDD.

A dynamic power-on-reset circuit is implemented in order to achieve the minimum current consumption in Sleep Mode. The VDD low level, the subsequent rise time, and the VDD rising slope must meet the requirements in Table 1.3 to guarantee an overall IC reset: lower VDD low levels allow slower rising of the subsequent on-ramp of VDD. Other combinations might also be possible. For example, the reset trigger can be influenced by increasing the power-down time and lowering the VDD rising slope requirement. Alternatively, the RES pin can be connected and used to control safe resetting of the IC. RES is low-active – a VDD-VSS-VDD transition at the RES pin leads to a complete ZSSC3018 reset.

Table 1.3 Requirements for VDD Power-on Reset (POR)

PARAMETER	SYMBOL	MIN	TYP	MAX	UNIT
Power Down Time (duration of VDD Low Level)	t_{SPIKE}	3	–	–	μs
VDD Low Level	V_{DDLOW}	0	–	0.2	V
VDD Rising Slope	SR_{VDD}	10	–	–	V/ms

1.3 Electrical Parameters

All parameter values are valid only under the specified operating conditions. All voltages are referenced to Vss.

Table 1.4 Electrical Parameters

Note: See important table notes at the end of the table.

Parameter	Symbol	Conditions/Comments	Min	Typ	Max	Unit
Supply						
External Sensor Supply Voltage, ADC Reference Voltage	V_{DDB}	Internally generated	1.60	1.68	1.75	V
Current Consumption	I_{VDD}	Active State, average	–	1050	1500	μA
		Sleep Mode, idle current, $\leq 85^{\circ}C$	–	20	250	nA
		Sleep Mode, idle current, $\leq 125^{\circ}C$	–	50	750	
Power Supply Rejection $20 \cdot \log_{10}(V_{DD}/V_{DDB})$ (see section 1.4)	PSR_{VDD}	$V_{DD} = 1.8V$	17	60	88	dB
		$V_{DD} = 2V$	32	65	91	dB
Analog-to-Digital Converter (ADC, A2D)						
Resolution	r_{ADC}		12	–	18	Bit
ADC Clock Frequency	f_{ADC}	Internal ADC clock	0.9	1	1.1	MHz
Conversion Rate	$f_{S,raw}$	Conversions per second for single 18-bit external sensor A2D conversion (w/o AZ)	–	–	1.1	kHz
		Conversions per second for single 16-bit temperature sensor A2D conversion (w/o AZ)	–	–	2.3	kHz
Amplifier						
Gain	G_{AMP}	64 steps	6.6	–	216	
Gain Error	G_{ERR}	Referenced to nominal gain	-2.5	–	2.5	%

Parameter	Symbol	Conditions/Comments	Min	Typ	Max	Unit
Sensor Signal Conditioning Performance						
IC Accuracy Error [a]	$Err_{A,IC}$	Accuracy error for ideally linear (in temperature and measurand) sensor	–	–	0.01	%FSO
Conversion Rate, 18-Bit Output with Sensor Signal Conditioning	$f_{S,SSC}$	Conversion per second for fully corrected 18-bit measurement	–	270	300	Hz
Input						
Input Voltage Range	V_{INP}, V_{INN}	Input voltage range at INP and INN	0.65	–	1.05	V
External Sensor Bridge Resistance	R_{BR}	Full power supply disturbance rejection (PSRR) capabilities	1	10	50	k Ω
		Reduced PSRR, but full functionality	100	–	999	Ω
Power-Up						
Start-up Time	t_{STA1}	V_{DD} ramp up to interface communication (see section 3.1)	–	–	1	ms
	t_{STA2}	V_{DD} ramp up to analog operation	–	–	2.5	ms
Wake-up Time	t_{WUP1}	Sleep to Active State interface communication	–	–	0.5	ms
	t_{WUP2}	Sleep to Active State analog operation	–	–	2	ms
Oscillator						
Internal Oscillator Frequency	f_{CLK}		3.6	4	4.4	MHz
Internal Temperature Sensor						
Temperature Resolution		-40°C to +125°C (Temperature resolution is 16 bits)	–	0.003	–	K/LSB
Interface and Memory						
SPI Clock Frequency	$f_{C,SPI}$	Maximum capacitance at MISO line: 40pF @ $V_{DD}=1.8V$	–	1	10	MHz
I ² C Clock Frequency	$f_{C,I2C}$		–	–	3.4	MHz
Program Time	t_{PROG}	MTP programming time per 16-bit register	–	5	16	ms
Endurance	n_{MTP}	Number of reprogramming cycles	1000	10000	–	numeric
Data Retention	t_{RET_MTP}	1000h @ 125°C	10	–	–	years

[a] Percentage referenced to maximum full-scale output (FSO); e.g. for 18-bit measurements:
 $Err_{A,IC} [\%FSO] = 100 \cdot \text{MAX}\{|ADC_{meas} - ADC_{ideal}|\} / 2^{18}$.

1.4 Power Supply Rejection Ratio (RSRR) versus Frequency

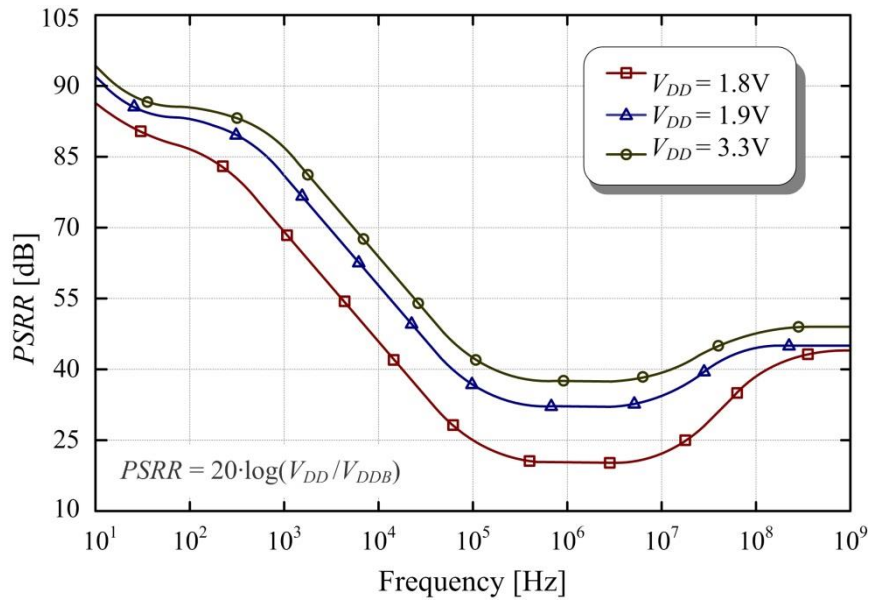

2. Circuit Description

2.1 Brief Description

The ZSSC3018 provides a highly accurate amplification of bridge sensor signals. The compensation of sensor offset, sensitivity, temperature drift, and non-linearity is accomplished via a 26-bit DSP core running a correction algorithm with calibration coefficients stored in a non-volatile memory. The ZSSC3018 can be configured for a wide range of resistive bridge sensor types and for absolute voltage-source sensors. A digital interface (SPI or I²C) enables communication. The ZSSC3018 supports two operational modes: Normal Mode and Command Mode. Normal Mode is the standard operating mode. Typically in Normal Mode, the ZSSC3018 wakes up from Sleep Mode (low power), runs a measurement in Active State, and automatically returns to the Sleep Mode. (See section 3.3 for details on operational modes.)

2.2 Signal Flow and Block Diagram

See Figure 2.1 and Figure 2.2 for the ZSSC3018 block diagram for different input sensors. The sensor bridge supply V_{DDB} and the power supply for analog circuitry are provided by a voltage regulator, which is optimized for power supply disturbance rejection (PSRR). See section 1.4 for a graph of PSRR versus frequency. To improve noise suppression, the digital blocks are powered by a separate voltage regulator. A power supervision circuit monitors all supply voltages and generates appropriate reset signals for initializing the digital blocks.

The System Control Unit controls the analog circuitry to perform the three measurement types: external sensor, temperature, and offset measurement. The multiplexer selects the signal input to the amplifier, which can be the external signals from the input pins INP and INN or the internal temperature reference sensor signals. A full measurement request will trigger an automatic sequence of all measurement types and all input signals.

Figure 2.1 ZSSC3018 Functional Block Diagram, Resistive-Bridge-Sensor

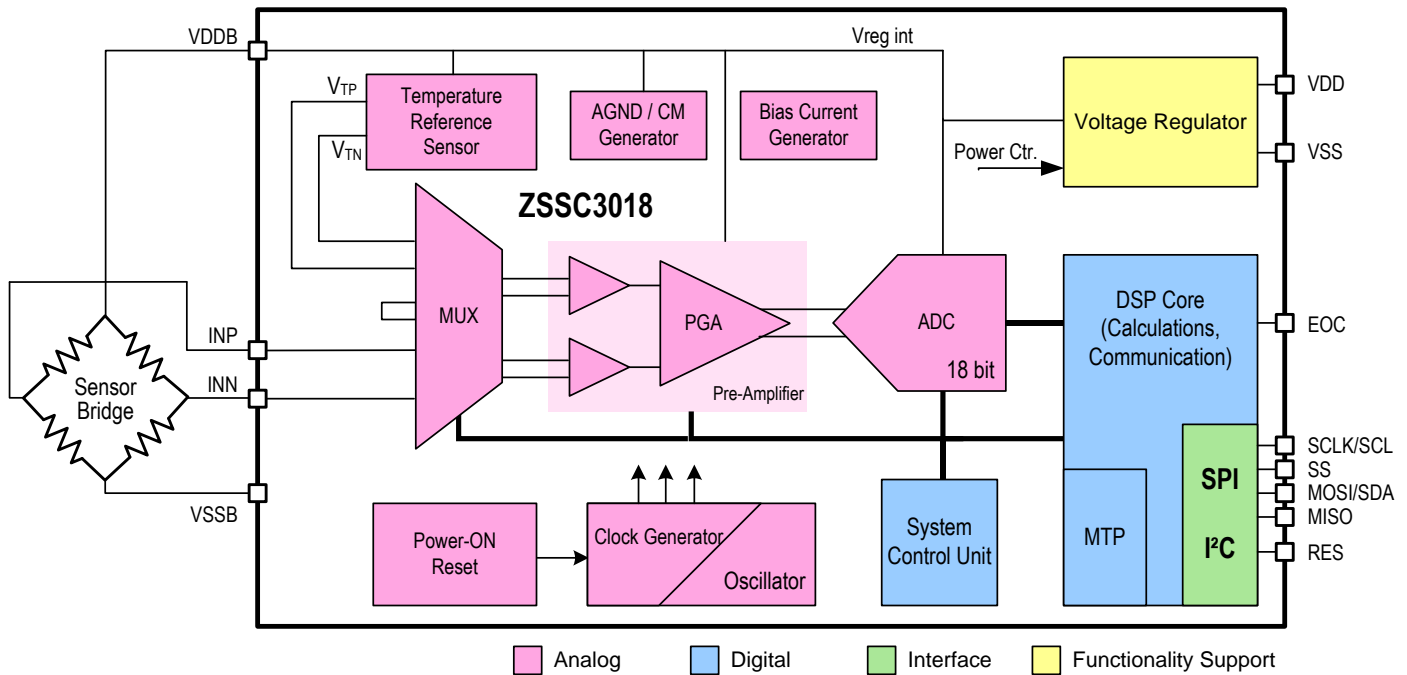
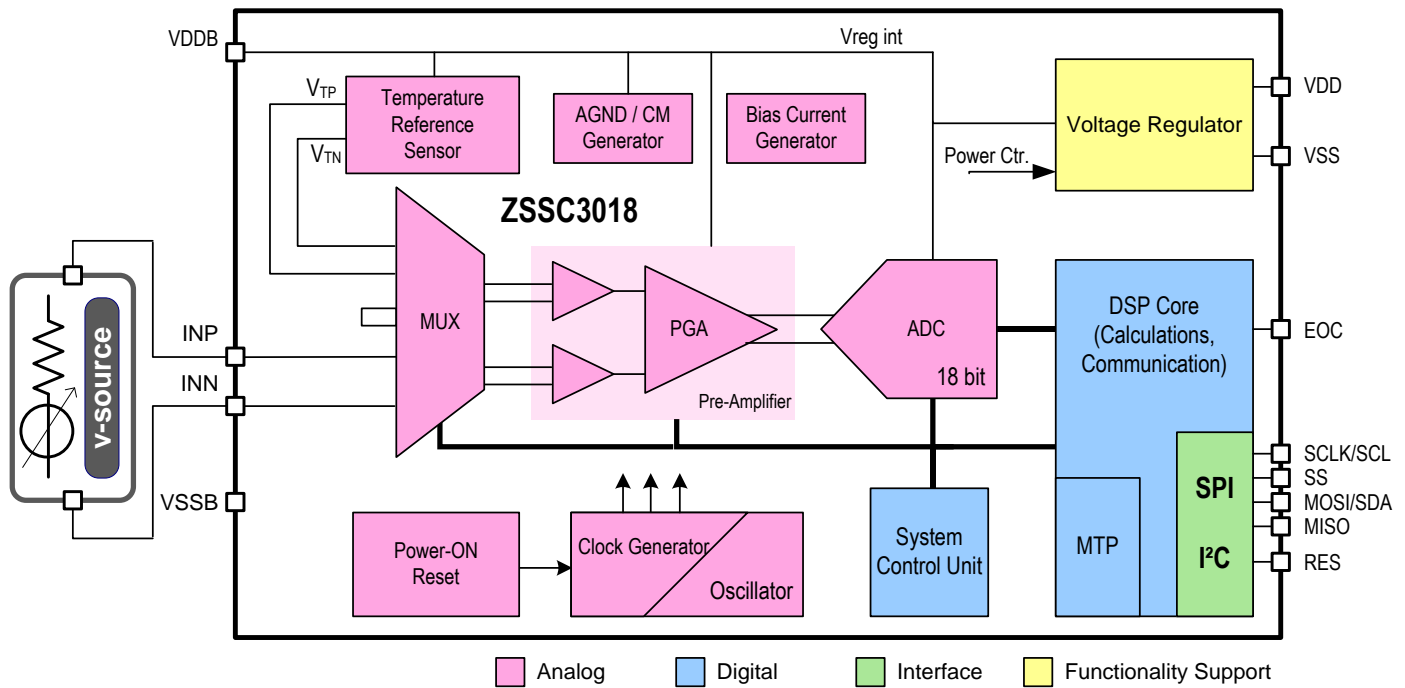

Figure 2.2 ZSSC3018 Functional Block Diagram, Voltage-Source-Sensor



The amplifier consists of two stages with programmable gain values.

The ZSSC3018 employs a programmable analog-to-digital converter (ADC) optimized for conversion speed and noise suppression. The programmable resolution from 12 to 18 bits provides flexibility for adapting the conversion characteristics. To improve power supply noise suppression, the ADC uses the bridge supply V_{DDB} as its reference voltage leading to a ratiometric measurement topology if the external sensor is a bridge-type element.

The remaining IC-internal offset and the sensor element offset, i.e., the overall system offset for the amplifier and ADC, can be canceled by means of an offset and auto-zero measurement, respectively.

The DSP accomplishes the auto-zero, span, and 1st and 2nd order temperature compensation of the measured external sensor signal. The correction coefficients are stored in the MTP memory.

The ZSSC3018 supports SPI and I²C interface communication for controlling the ZSSC3018, configuration, and measurement result output.

2.3 Analog Front End

2.3.1 Amplifier

The amplifier has a fully differential architecture and consists of two stages. The amplification of each stage and the external sensor gain polarity are programmable via settings in the Measurement Configuration Registers *SM_config1* and *SM_config2* (addresses 12_{HEX} and 16_{HEX}; see section 3.6.2) in the MTP memory (see section 2.4.2). Only one of these two possible configurations is used for measurements. The default configuration is *SM_config1*. Alternately, *SM_config2* can be implemented by sending a command to select this configuration for the measurement (see section 3.5.1). The term *SM_config* is used for general register content and functionality explanations for both, *SM_config1* and *SM_config2*, as the registers' bit assignments are exactly the same for both registers.

The first 6 bits of *SM_config* are the programmable gain settings *Gain_stage1* and *Gain_stage2*. The options for the programmable gain settings are listed in Table 2.1 and Table 2.2.

Table 2.1 Amplifier Gain: Stage 1

Gain_stage1			
<i>SM_config</i> Bit G2	<i>SM_config</i> Bit G1	<i>SM_config</i> Bit G0	Gain _{amp1}
0	0	0	6
0	0	1	12
0	1	0	20
0	1	1	30
1	0	0	40
1	0	1	60
1	1	0	80
1	1	1	120

Table 2.2 Amplifier Gain: Stage 2

Gain_stage2			
<i>SM_config</i> Bit G5	<i>SM_config</i> Bit G4	<i>SM_config</i> Bit G3	Gain _{amp2}
0	0	0	1.1
0	0	1	1.2
0	1	0	1.3
0	1	1	1.4
1	0	0	1.5
1	0	1	1.6
1	1	0	1.7
1	1	1	1.8

If needed, the polarity of the sensor bridge gain can be reversed by setting the *Gain_polarity* bit, which is bit 6 in the *SM_config* register (see section 3.6.2). Changing the gain polarity is achieved by inverting the chopper clock. Table 2.3 gives the settings for the *Gain_polarity* bit. This feature enables applying a sensor to the ZSSC3018 with swapped input signals at INN and INP; e.g., to avoid crossing wires for the final sensor module's assembly.

Table 2.3 Gain Polarity

<i>Gain_polarity</i> (SM_config Bit 6)	Gain	Setting Description
0	+1	No polarity change.
1	-1	Gain polarity is inverted.

2.3.2 Analog-to-Digital Converter

An analog-to-digital converter (ADC) is used to digitize the amplifier signal. To allow optimizing the trade-off between conversion time and resolution, the resolution can be programmed from 12-bit to 18-bit (see *Adc_bits*, *SM_config* register; section 3.6.2). The ADC processes differential input signals.

Table 2.4 ADC Conversion Times for a Single A2D Conversion

Resolution [Bits]	Conversion Time in μ s (typical)
12	140
13	185
14	250
15	335
16	470
17	640
18	890

The ADC can perform an offset shift in order to adapt input signals with offsets to the ADC input range. The shift feature is enabled by setting *SM_config* registers' bit[15] = 1 (*Shift_method* = 1). The respective analog offset shift can be set up with bits[14:12], the *Offset* bit field in *SM_config*.

Note: The offset shift causes the ADC to perform an additional amplification of the ADC's input signal by a factor of 2. This must be considered for a correct analog sensor setup using the pre-amplifier's gain, the ADC offset shift, and the potential ADC gain.

The overall analog amplification $Gain_{total} = Gain_{amp1} * Gain_{amp2} * Gain_{ADC}$ can be determined for the following options:

- If no offset shift is selected, i.e. *Shift_method* = 0 and *Offset* = 000 in *SM_config*:

$$Gain_{total} = Gain_{amp1} * Gain_{amp2} * 1$$

- If ADC offset shift is selected, i.e. *Shift_method* = 1 and *Offset* \neq 000 in *SM_config*:

$$Gain_{total} = Gain_{amp1} * Gain_{amp2} * 2$$

Table 2.5 ADC Offset Shift

SM_config Bit 15 (Shift_method)	Offset Shift in ADC				Gain _{ADC}	ADC Offset Shift of Input Signal as a Percent of Full Scale
	Offset: SM_config Bit 14	Offset: SM_config Bit 13	Offset: SM_config Bit 12			
0	0	0	0	1	0%	
1	0	0	0	2	0%	
1	0	0	1	2	6.75%	
1	0	1	0	2	12.50%	
1	0	1	1	2	19.25%	
1	1	0	0	2	25.00%	
1	1	0	1	2	31.75%	
1	1	1	0	2	38.50%	
1	1	1	1	2	43.25%	

Important: If the required configuration is no offset shift and no additional gain factor (and therefore $Gain_{ADC} = 1$), then the only valid settings are $Shift_method = 0$ and $Offset = 000$ in SM_config . Any other setup using $Shift_method = 0$ combined with $Offset \neq 000$ leads to erroneous analog setups.

The setting for ADC resolution for the external sensor (bridge or voltage-source sensor) affects the typical measurement duration and noise performance as shown in Table 2.6 for the example of a bridge sensor measurement using the “Measure” command (AA_{HEX}; see section 3.4.1). See section 3.2 for definitions of measurement types AZSM, SM, AZTM, and TM.

Table 2.6 Typical Conversion Times versus Noise Performance with Full Sensor Signal Conditioning for Measurement Including AZSM, SM, AZTM, and TM (Bridge-Type Sensor)

Note: See important table notes at the end of this table.

ADC Resolution: Internal Temperature Sensor	ADC Resolution: External Sensor	Typical Measurement Duration ^[a] , MEASURE, (AA _{HEX}) [ms]	Typical 3-Sigma Noise for SSC-Corrected Output ^[b] [counts]
16	12	2.2	2.4
16	13	2.3	2.5
16	14	2.4	3.0
16	15	2.6	4.4

ADC Resolution: Internal Temperature Sensor	ADC Resolution: External Sensor	Typical Measurement Duration ^[a] , MEASURE, (AA _{HEX}) [ms]	Typical 3-Sigma Noise for SSC-Corrected Output ^[b] [counts]
16	16	2.8	5.7
16	17	3.2	10.5
16	18	3.7	18.0

[a] Measurement duration is defined as the time from the high/low transition on the EOC pin at the beginning of the measurement until the next low/high transition on the EOC signal at the end of a single measurement in Sleep Mode.

[b] Reference noise values normalized to the external sensor's ADC resolution; obtained with the setup: 20kΩ sensor bridge, 25°C operating temperature, gain=52, ADC offset=25%, VDD=1.8V.

2.3.3 Selection of Gain and Offset – Sensor System Dimensioning

The optimal gain (and offset) setup for a specific sensor element can be determined by the following steps:

1. Collect sensor element's characteristic, statistical data (over temperature, ambient sensor parameter, and over production tolerances):
 - a. Minimum differential output voltage: V_{min}
 - b. Maximum differential output voltage: V_{max}

Note: The best possible setup can only be determined if the absolute value of V_{max} is greater than the absolute value of V_{min} . If this is not the case, the gain polarity should be reversed by means of the *Gain_polarity* bit in the *SM_config* register (see section 3.6.2).

2. Calculate:
 - a. Common mode level; i.e., differential offset of the sensor output:

$$V_{CM} = 0.5 * (V_{max} + V_{min})$$
 - b. Relative or percent offset of the sensor output:

$$Offset_{sensor}[\%] = \frac{V_{CM}}{V_{max} - V_{min}} * 100\%$$
3. Determine which of the two following cases is valid.
 - a. If $Offset_{sensor}[\%] > 43\%$ then select $Offset = 111$ (i.e., 43.25%)
 - b. If $0\% < Offset_{sensor}[\%] < 43\%$ then select $Offset \leq Offset_{sensor}[\%]$ (see Table 2.5 for possible ADC *Offset* setup values)
4. The total required, optimum gain can be determined as

$$Gain_{total, opt} = \frac{1.4V}{V_{max} * \left(1 - \frac{Offset_{sensor}}{100}\right)}$$

Configure gain factors in the following step such that $Gain_{total} \leq Gain_{total, opt}$ (see section 2.3.1).

5. The gain setup can be separated into the three factors $Gain_{amp1}$, $Gain_{amp2}$ (for the stage 2 amplifier) and $Gain_{ADC}$ (1 for no-shift or 2 for shift operation) according to

$$Gain_{total} = Gain_{amp1} * Gain_{amp2} * Gain_{ADC}$$

- a. If no offset shift is performed ($Shift_method = 0$ and $Offset = 000$), the amplifier gain is $Gain_{total}$.
- b. If an offset shift is performed ($Shift_method = 1$), the amplifier gain is $0.5 * Gain_{total}$.

Figure 2.3 ADC Gain and Offset Setup

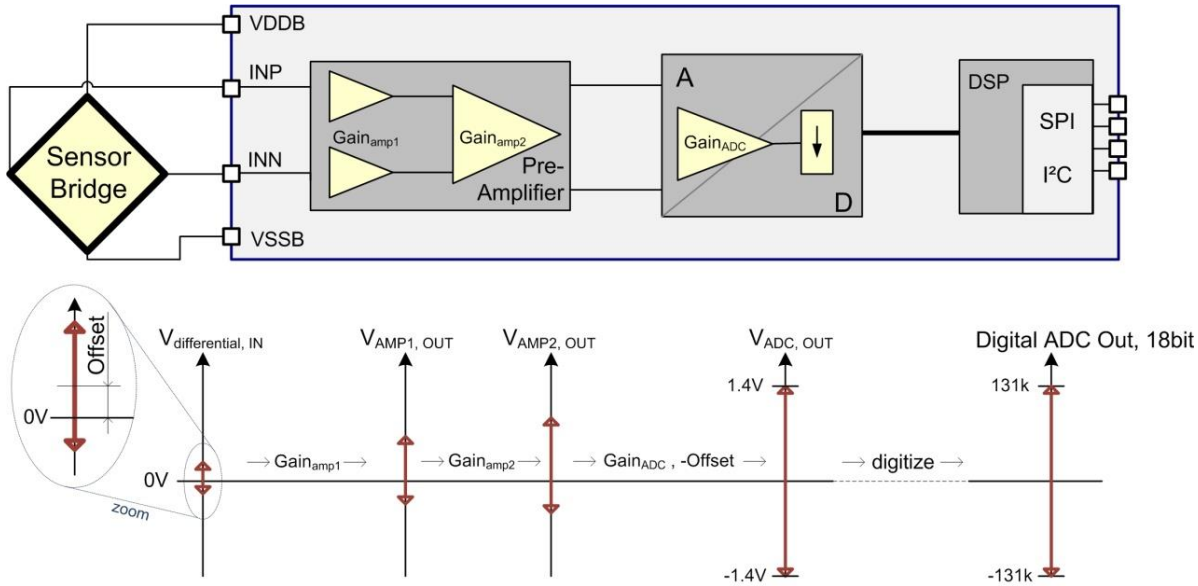

2.3.4 Temperature Measurement

The ZSSC3018 provides an internal temperature sensor measurement to allow compensation for temperature effects. See section 1.3 for the temperature sensor resolution. The temperature output signal is a differential voltage that is adapted by the amplifier for the ADC input.

For temperature measurements, the respective settings are defined and programmed to the MTP by Renesas.

2.3.5 External Sensor Supply: Bridge Sensors

The ZSSC3018 provides dedicated supply pins VDDB and VSSB for resistive bridge-type sensors (*AbsV_enable* bit[11]=0 in *SM_config* registers 12_{HEX} or 16_{HEX}; see section 3.6.2). The ADC reference voltages for the sensor bridge measurement are derived from these internal voltages such that bridge supply disturbances are suppressed. The current drive ability of V_{DDB} is limited (see I_{VDDB} in section 1.2).

2.3.6 External Sensor: Absolute Voltage Source Sensors

As an optional alternative to a bridge sensor application, the ZSSC3018 can process signals from an absolute-voltage source sensor; e.g., a thermopile element. The respective input type can be selected with *AbsV_enable* bit[11]=1 in *SM_config*, registers 12_{HEX} or 16_{HEX}. The absolute-voltage source sensor element must be connected between the INP and INN pins; INN is internally connected to the ZSSC3018’s analog ground (important: this is not VSSB). Do not connect VDDB and VSSB if an absolute-voltage source sensor is applied. The offset shift should be set to maximum in this case: *Shift_method* = 1 and *Offset* = 111 in *SM_config*. The required gain can be determined according to the procedure described in section 2.3.3.

2.4 Digital Section

2.4.1 Digital Signal Processor (DSP) Core

The DSP core block performs the algorithm for correcting the sensor signal. The required coefficients are stored in the MTP memory.

When the measurement results are available, the "end of conversion" signal is set at the EOC pin if no interrupt-threshold has been set up (bits[8:7]=00 in register 02_{HEX}; see section 3.6.2). The internal EOC information is valid only if both the measurement and calculation have been completed. Alternatively, the EOC pin can indicate exceeding or underrunning a specified threshold or leaving a valid-result range as described in section 3.3.

2.4.2 MTP Memory

The ZSSC3018's memory is designed with a true multiple-time programmable (MTP) structure. The memory is organized in 16-bit registers that can be re-written multiple (at least 1000) times. The user has access to a 57 x 16-bit storage area for values such as calibration coefficients. The required programming voltage is generated internally in the ZSSC3018. A checksum of the whole memory is evaluated for integrity-checking purposes. The checksum can be generated with command 90_{HEX} (see section 3.4.1).

2.4.3 Clock Generator

The clock generator provides approximately 4MHz, and 1MHz clock signals as the time base for IC-internal signal processing. The frequency is trimmed during production test.

2.4.4 Power Supervision

The power supervision block, which is a part of the voltage regulator combined with the digital section, monitors all power supplies to ensure a defined reset of all digital blocks during power-up or power supply interruptions. "Brown-out" events at the supply that do not meet the power-on-reset (POR) requirements (see Table 1.3), must be resolved with a reset pulse at the RES pin.

2.4.5 Interface

The ZSSC3018 can communicate with the user's communication master or computer via an SPI or I²C interface*. The interface type is selectable by the first activity at the interface immediately after power-up or reset:

- a. If the first command is an I²C command and the SS pin has been inactive until this command is received, the ZSSC3018 enters I²C Mode.
- b. If the first interface action sets the SS pin to active (active-HIGH or active-LOW depends on the SS_polarity bit[9] in register 02_{HEX}; see section 3.6.2), then the ZSSC3018 enters SPI Mode.

Note: During the initiation sequence (after power-up or reset) any potential transition on SS is ignored. Switching to SPI Mode is only possible after the power-up sequence. If SS is not connected, the SS pin internal pull-up keeps the ZSSC3018 in I²C™ Mode.

To also provide interface accessibility in Sleep Mode (all features inactive except the digital interface logic), the interface circuitry is directly supplied by VDD.

* Functional I²C interface properties correspond to the NXP I²C Bus Specification Rev. 0.3 (June 2009).

3. Functional Description

3.1 Power-Up

Specifications related to power-up are given in sections 1.2 and 1.3. On power-up, the ZSSC3018 communication interface is able to receive the first command after the time t_{STA1} from when the VDD supply is within operating specifications. The ZSSC3018 can begin the first measurement after the time t_{STA2} from when the VDD supply is operational. As an alternative to a power-on-reset, a reset and new power-up-sequence can be triggered by an IC-reset signal (high low) at the RES pin.

The wake-up time from Sleep Mode to Active State (see section 3.3) after receiving the activating command is defined as t_{WUP1} and t_{WUP2} . In Command Mode, subsequent commands can be sent after t_{WUP1} . The first measurement starts after t_{WUP2} if a measurement request has been sent.

3.2 Measurements

Available measurement procedures are

- AZSM: auto-zero (external) sensor measurement
- SM: (external) sensor measurement
- AZTM: auto-zero temperature measurement
- TM: temperature measurement

AZSM: The configuration for the external sensor measurement, i.e. a resistive bridge or an absolute-voltage source, is loaded. The multiplexer block connects the amplifier input to the AGND analog ground reference. An analog-to-digital conversion is performed so that the inherent system offset for the respective configuration is converted by the ADC to a digital value, quantized according to the respective MTP configuration.

SM: The configuration for the external sensor measurement, i.e. a resistive bridge or an absolute-voltage source, is loaded. The multiplexer connects the amplifier input to the INP and INN pins accordingly. An analog-to-digital conversion is performed. The result is a digital value with a resolution according to the MTP configuration.

AZTM: The configuration for temperature measurements is loaded. The multiplexer connects the amplifier input to AGND. An analog-to-digital conversion is performed so that the inherent system offset for the temperature configuration is converted by the ADC to a digital value, quantized according to the respective MTP configuration.

TM: The configuration for temperature measurements is loaded. The multiplexer connects the amplifier input to the internal temperature sensor. An analog-to-digital conversion is performed. The result is a digital value with a resolution according to the MTP configuration.

The typical application's measurement cycle is a complete SSC measurement (using one of the commands AA_{HEX} to AF_{HEX}) with AZSM, SM, AZTM, and TM followed by a signal correction calculation.

3.3 Interrupt (EOC Pin)

The EOC pin can be programmed to operate either as a pure "measurement busy" and end-of-conversion (EOC) transducer, or as a configurable interrupt transducer. The respective basic operation must be programmed to the *INT_setup* bits [1:0] in register 02_{HEX} [8:7] (see section 3.6.2). One or two 24-bit-quantized thresholds can be programmed (TRSH1, TRSH2 in memory registers 13_{HEX} , 14_{HEX} and 15_{HEX}).

Dependent on the *INT_setup* selection, the EOC pin provides a logic 1 or logic 0 (also dependent on the respective interface setup; e.g., SPI with logic 0 \Leftrightarrow VDD or logic 0 \Leftrightarrow VSS, etc.) according to the SSC-corrected result. The respective thresholds are programmed left-aligned in the memory, such that they must be programmed with the threshold's MSB in the memory register's MSB, etc. The LSBs of the 24-bit threshold in the memory must be truncated to the number of bits of the selected ADC resolution (according to *Adc_bits*).

The interrupt functionality is only available for digital values from the SSC-calculation unit – raw values cannot be monitored by the interrupt feature. Figure 3.1 and Figure 3.2 show the different setup options and the respective response at the EOC pin. The use of the interrupt functionality is recommended for cyclic operation. Only in cyclic operation (command AB_{HEX} with respective power-down setup in the 02_{HEX} register *Interface Configuration*), the EOC-level continuously represents the respective SSC-measurement result. For single or oversample measurement requests without cyclic operation, the EOC output signal is reset to logical zero at the beginning of each new measurement, even though the interrupt thresholds are established correctly (setting EOC to logical one or zero is dependent on interrupt setup) at the end of each measurement.

Figure 3.1 Interrupt Functionality: INT_setup = 01 and INT_setup = 10

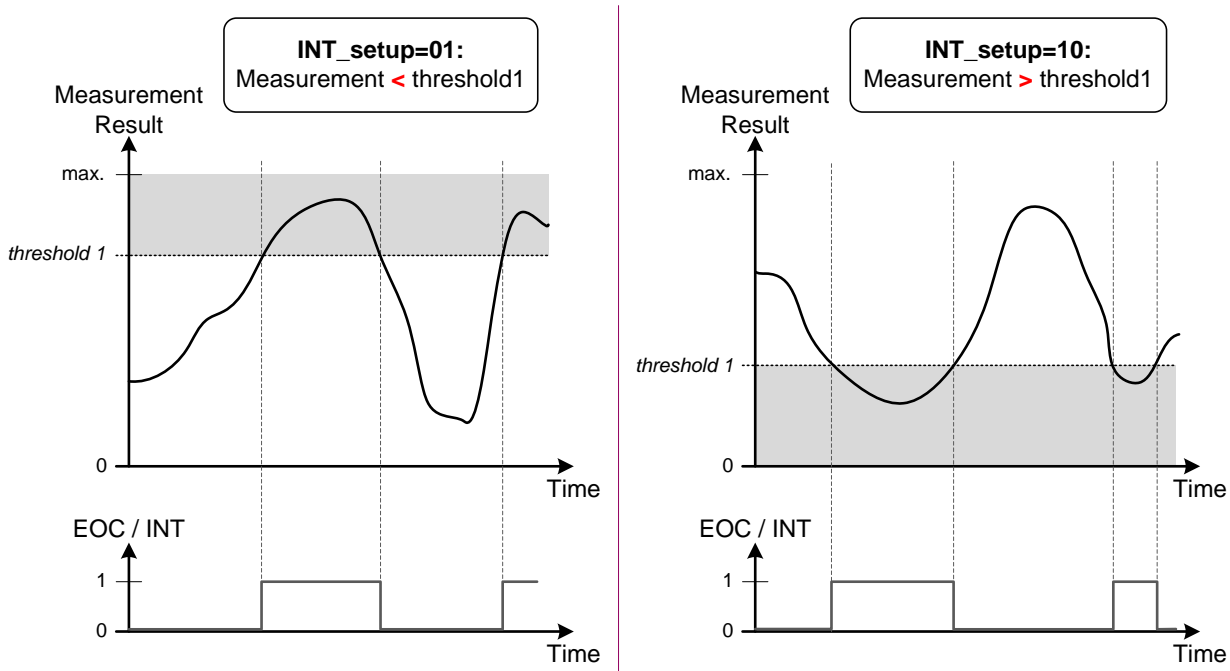
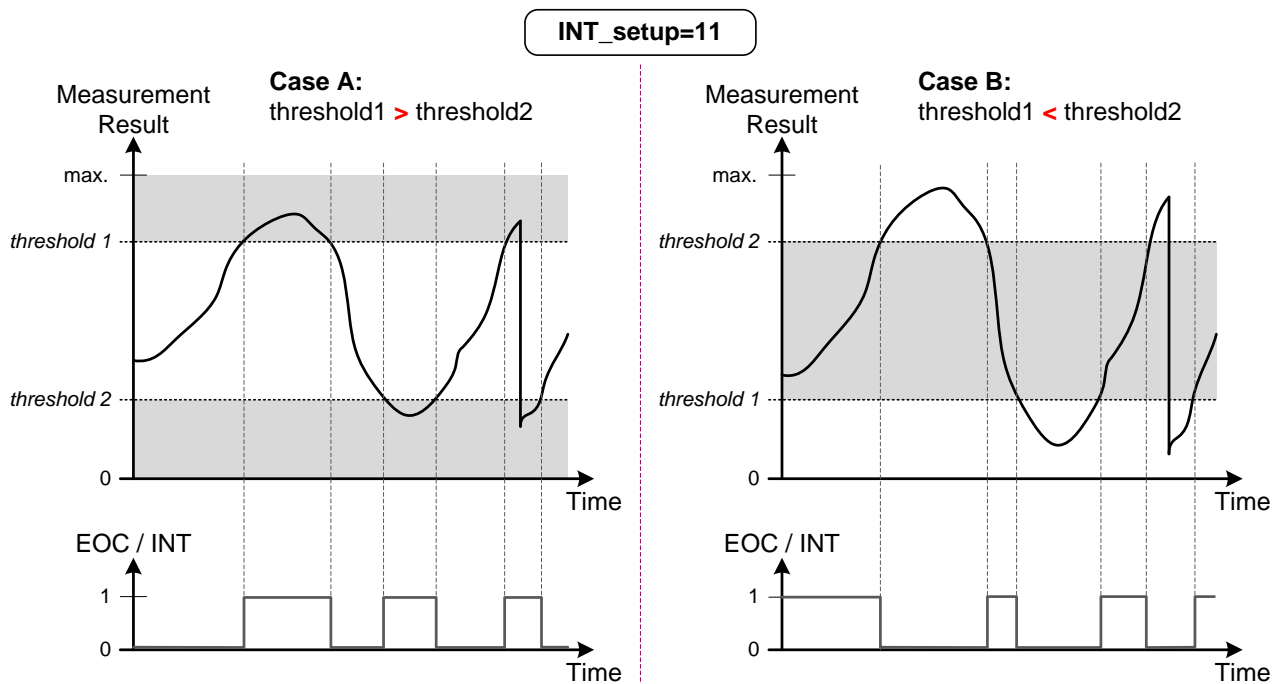

Figure 3.2 Interrupt Functionality: INT_setup = 11



3.4 Operational Modes

Figure 3.3 illustrates the ZSSC3018 power-up sequence and subsequent operation depending on the selected interface communication mode (I²C or SPI) as determined by interface related first activities after power-up or reset. If the first command after power-up is a valid I²C™ command, the interface will react as an I²C interface until the next power-on-reset (POR). If there is no valid I²C command, but an active signal at the SS pin is detected as the first valid activity, then the interface will respond as an SPI slave. With either interface, after the voltage regulators are switched on, the ZSSC3018's low voltage section (LV) is active while the related interface configuration information is read from memory. Then the LV section is switched off, the ZSSC3018 goes into Sleep Mode, and the interface is ready to receive commands. Since the interface is always powered by V_{DD}, it is referred to as the high voltage section (HV).

See Table 3.1 for definitions of the commands.

Figure 3.4 shows the ZSSC3018 operation in Normal Mode (with two operation principles: "Sleep" and "Cyclic") and Command Mode including when the LV and HV sections are active as indicated by the color legend. The Normal Mode automatically returns to Sleep Mode after executing the requested measurements, or periodically wakes up and conducts another measurement according to the selection of the "sleep duration" with the *CYC_period* (bits[14:12] in memory register 02_{HEX}). In Command Mode, the ZSSC3018 remains active if a dedicated command (Start_NOM) has been sent, which is helpful during calibration. Command Mode can only be entered if Start_CM (command A9_{HEX}; see Table 3.1) is the first command received after POR.

Figure 3.3 Operational Flow Chart: Power Up

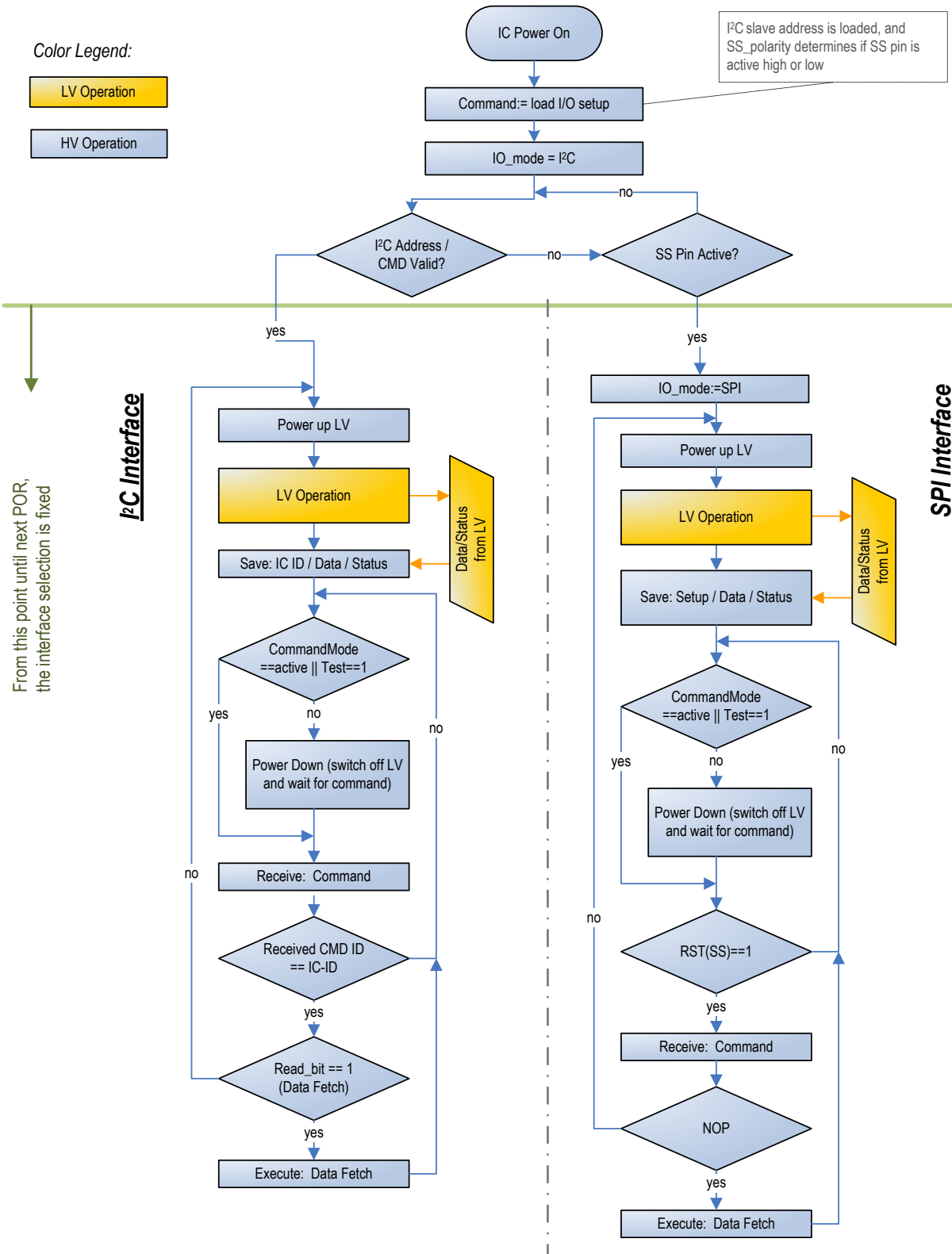
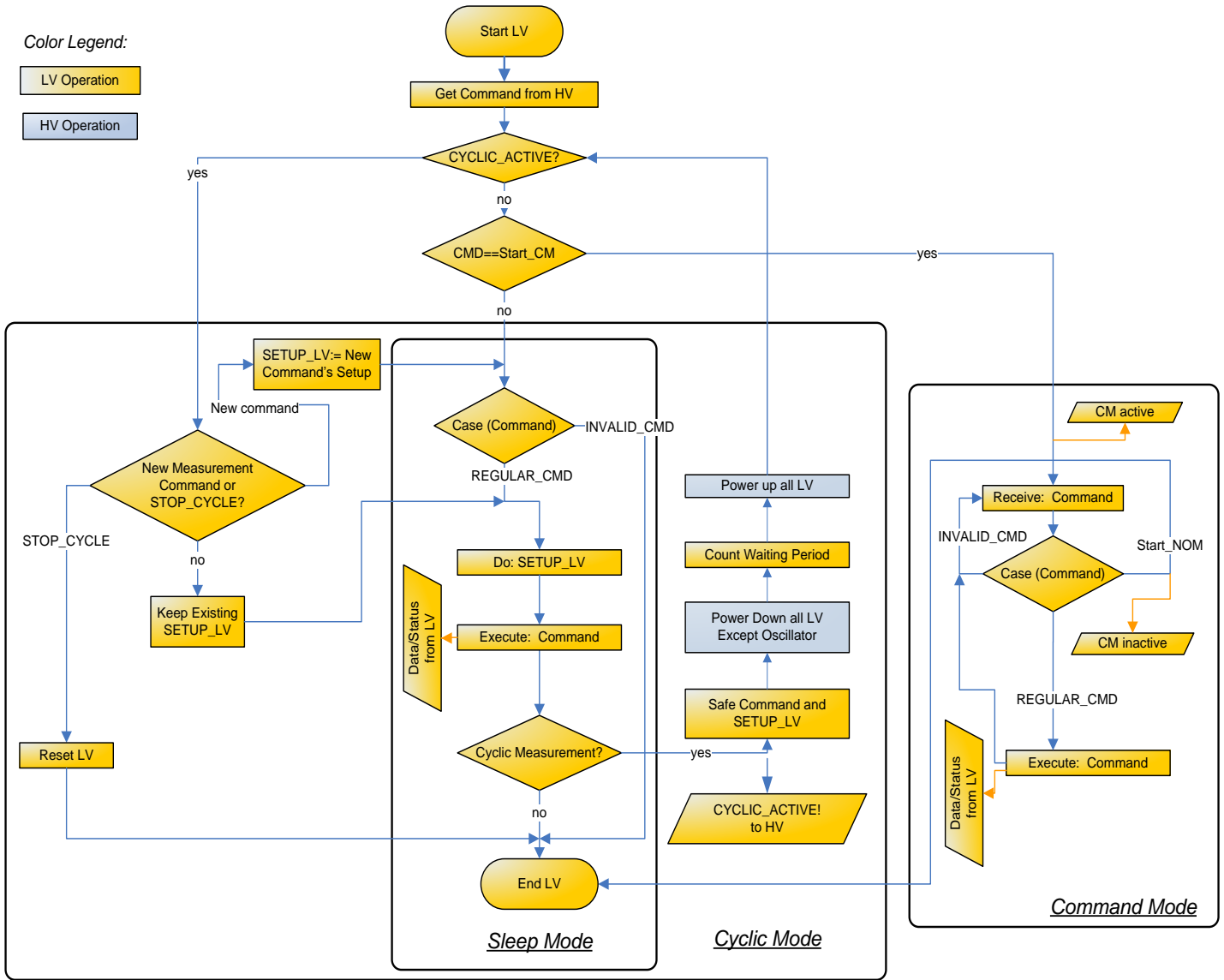

Figure 3.4 Operational Flow Chart: Command Mode and Normal Mode (Sleep and Cyclic)



3.4.1 SPI/I²C Commands

The SPI/I²C commands supported by the ZSSC3018 are listed in Table 3.1. The command to read an address in the user memory is the same as its address. The command to write to an address in user memory is the address plus 40_{HEX}.

There is a Renesas-reserved section of memory that can be read but not over-written by the user.

Table 3.1 SPI/I²C Commands

Note: Every return starts with a status byte followed by the data word as described in section 3.5.1.

Note: The output for any ADC measurement and signal conditioning calculation is formatted as a 24-bit data word, regardless of the effective ADC resolution used.

Command (Byte)	Return	Description	Normal Mode	Command Mode
00 _{HEX} to 39 _{HEX}	16-bit user data	Read data in the user memory address (00 _{HEX} to 39 _{HEX}) matching the command (might not be using all addresses).	yes	yes
3A _{HEX} to 3F _{HEX}	16-bit Renesas-reserved memory data	Read data in Renesas-reserved memory at address (3A _{HEX} to 3F _{HEX}).	yes	yes
40 _{HEX} to 79 _{HEX} followed by data (0000 _{HEX} to FFFF _{HEX})	–	Write data to user memory at address specified by command minus 40 _{HEX} (addresses 00 _{HEX} to 39 _{HEX} respectively; might not be using all addresses).	yes	yes
90 _{HEX}	–	Calculate and write memory checksum (CRC)	yes	yes
A0 _{HEX} to A7 _{HEX} followed by XXXX _{HEX} (see Table 3.2)	24-bit formatted raw data	Get_Raw This command can be used to perform a measurement and write the raw ADC data into the output register. The LSB of the command determines how the AFE configuration register is loaded for the Get_Raw measurement (see Table 3.2).	yes	yes
A8 _{HEX}	–	Start_NOM Exit Command Mode and transition to Normal (Sleep or Cyclic) Mode.	no	yes
A9 _{HEX}	–	Start_CM Exit Normal Mode and transition to Command Mode (as very first command after power-up).	yes	no
AA _{HEX}	24-bit formatted fully corrected sensor measurement data + 24-bit corrected temperature data	Measure Triggers full measurement cycle (AZSM, SM, AZTM, and TM, as described in section 3.2) and calculation and storage of data in interface (configurations from MTP).	yes	yes
AB _{HEX}	24-bit formatted fully corrected sensor measurement data + 24-bit corrected temperature data	Measure Cyclic Triggers continuous full measurement cycle (AZSM, SM, AZTM, and TM, as described in section 3.2) and calculation and storage of data in interface (configurations from MTP) followed by pause according to <i>CYC_period</i> (bits[14:12] in register 02 _{HEX})	yes	yes

Command (Byte)	Return	Description	Normal Mode	Command Mode
AC _{HEX}	24-bit formatted fully corrected sensor measurement data + 24-bit corrected temperature data	Oversample-2 Measure Mean value generation: 2 full measurements (as in command AA _{HEX}) are conducted, the mean value of the measurements is calculated, and the data is stored in the interface (configurations from MTP); no power down or pause between the 2 measurements	yes	yes
AD _{HEX}	24-bit formatted fully corrected sensor measurement data + 24-bit corrected temperature data	Oversample-4 Measure Mean value generation: 4 full measurements (as in command AA _{HEX}) are conducted, the mean value of the measurements is calculated, and the data is stored in the interface (configurations from MTP), no power down or pause between the 4 measurements	yes	yes
AE _{HEX}	24-bit formatted fully corrected sensor measurement data + 24-bit corrected temperature data	Oversample-8 Measure Mean value generation: 8 full measurements (as in command AA _{HEX}) are conducted, the mean value of the measurements is calculated, and the data is stored in the interface (configurations from MTP), no power down or pause between the 8 measurements	yes	yes
AF _{HEX}	24-bit formatted fully corrected sensor measurement data + 24-bit corrected temperature data	Oversample-16 Measure Mean value generation: 16 full measurements (as in command AA _{HEX}) are conducted, the mean value of the measurements is calculated, and the data is stored in the interface (configurations from MTP), no power down or pause between the 16 measurements	yes	yes
B0 _{HEX}	–	Select 1st, SM_config1 register (12 _{HEX} in memory) For any measurement using the memory content for analog front-end / sensor setup, the respective setup is loaded from SM_config1 register, status bit[1]=0 (default)	yes	yes
B1 _{HEX}	–	Select 2nd, SM_config2 register (16 _{HEX} in memory) For any measurement using the memory content for analog front-end / sensor setup, the respective setup is loaded from the SM_config2 register, status bit[1]=1	yes	yes
BF _{HEX}	–	STOP_CYC Causes power-down leading to halting update / cyclic measurement operation and transition from Normal to Sleep Mode.	yes	yes
FX _{HEX}	Status followed by last 24-bit data	NOP Only valid for SPI (see sections 3.5.1 and 3.5.2).	yes	yes

Table 3.2 Get_Raw Commands

Command	Measurement	AFE Configuration Register
A0 _{HEX} followed by 0000 _{HEX}	SM – Sensor Measurement	<i>SM_config</i>
A1 _{HEX} followed by ssss _{HEX}	SM – Sensor Measurement	sss is the user's configuration setting for the measurement provided via the interface. The format and purpose of the configuration bits must be according to the definitions for <i>SM_config</i> .
A2 _{HEX} followed by 0000 _{HEX}	SM-AZSM – Auto-Zero Corrected Sensor Measurement ^[a]	<i>SM_config</i>
A3 _{HEX} followed by ssss _{HEX}	SM-AZSM – Auto-Zero Corrected Sensor Measurement ^[b]	sss is the user's configuration setting for the measurement provided via the interface. The format and purpose of configuration bits must be according to the definitions for <i>SM_config</i> .
A4 _{HEX} followed by 0000 _{HEX}	TM – Temperature Measurement	Renesas-defined register
A5 _{HEX} followed by ssss _{HEX}	TM – Temperature Measurement	sss is the user's configuration setting for the measurement provided via the interface. The format and purpose of configuration bits must be according to the definitions for <i>SM_config</i> and valid for temperature measurement in this case (bits [15:13] will be ignored).
A6 _{HEX} followed by 0000 _{HEX}	TM-AZTM – Auto-Zero Corrected Temperature Measurement ^[a]	Renesas-defined register
A7 _{HEX} followed by ssss _{HEX}	TM-AZTM – Auto-Zero Corrected Temperature Measurement ^[b]	sss is the user's configuration setting for the measurement provided via the interface. The format and purpose of configuration bits must be according to the definitions for <i>SM_config</i> being valid for temperature measurement in this case (bits [15:13] will be ignored).

[a] Recommended for raw data collection during calibration coefficient determination using pre-programmed (in MTP) measurement setups.

[b] Recommended for raw data collection during calibration coefficient determination using un-programmed (not in MTP), external measurement setups; e.g., for evaluation purposes.

3.5 Communication Interface

3.5.1 Common Functionality

Commands are handled by the command interpreter in the LV section. Commands that need additional data are not treated differently than other commands because the HV interface is able to buffer the command and all the data that belongs to the command and the command interpreter is activated as soon as a command byte is received.

Every response starts with a status byte followed by the data word. The data word depends on the previous command. It is possible to read the same data more than once if the read request is repeated (I²C) or a NOP command is sent (SPI). If the next command is not a read request (I²C) or a NOP (SPI), it invalidates any previous data.

The ZSSC3018 supports the parallel setup of two amplifier-ADC configurations by means of *SM_config1* (default) and *SM_config2*. Switching between the two setups can be done with the commands B0_{HEX} (selects *SM_config1*) and B1_{HEX} (selects *SM_config2*), whereas the respective activation command must always be sent prior to the measurement request.

The status byte contains the following bits (see Table 3.3, for sequence):

- Power indication (bit 6): 1 if the device is powered (V_{DDB} on); 0 if not powered. This is needed for SPI Mode where the master reads all zeros if the device is not powered or in power-on reset (POR).
- Busy indication (bit 5): 1 if the device is busy, which indicates that the data for the last command is not available yet. No new commands are processed if the device is busy.
Note: The device is always busy if the cyclic measurement operation has been set up and started.
- Actual ZSSC3018 mode (bits 4:3): 00 = Normal Mode; 01 = Command Mode; 1X = Renesas-reserved. See Table 3.4.
- Memory integrity/error flag (bit 2): 0 if integrity test passed, 1 if test failed. This bit indicates whether the checksum-based integrity check passed or failed. The memory error status bit is calculated only during the power-up sequence, so a newly written CRC will only be used for memory verification and status update after a subsequent ZSSC3018 power-on reset (POR) or reset by means of the RES pin.
- Config Setup (bit 1): Indicates the selection of the *SM_config* register being used (register 12_{HEX}: *SM_config1* or register 16_{HEX}: *SM_config2*). The respective separate configuration setup allows two different configurations of the external sensor channel in order to support up to two application scenarios with the use of only one sensor-IC pair. This bit is 0 (default) if *SM_config1* was selected. This bit is 1 if *SM_config2* was selected.
- ALU saturation (bit 0): If the last command was a measurement request, this bit is 0 if any intermediate value and the final SSC result are in a valid range and no SSC-calculation internal saturation occurred, respectively. If the last command was a measurement request, this bit is 1 if an SSC-calculation internal saturation occurred. This bit is also 0 for any non-measurement command.

Table 3.3 General Status Byte

Bit	7	6	5	4	3	2	1	0
Meaning	0	Powered?	Busy?	Mode		Memory error?	Config Setup	ALU Saturation

Table 3.4 Mode Status

Status[4:3]	Mode
00	Normal Mode (sleep and cyclic operations)
01	Command Mode
10	Renesas-Reserved
11	Command Mode and Reserved

Further status information can be provided by the EOC pin. The EOC pin is set high when a measurement and calculation have been completed (if no interrupt threshold is used; i.e., $INT_setup=00_{BIN}$, see section 3.3).

3.5.2 SPI

The SPI Mode is available if the very first interface activity (after ZSSC3018 power-up) is an active signal at the SS pin. The polarity and phase of the SPI clock are programmable via the CKP_CKE setting in register 02_{HEX} as described in Table 3.5. CKP_CKE is two bits: $CPHA$ (bit 10), which selects which edge of SCLK latches data, and $CPOL$ (bit 11), which indicates whether SCLK is high or low when it is idle. The polarity of the SS signal and pin are programmable via the $SS_polarity$ setting (bit 9). The different combinations of polarity and phase are illustrated in the figures below.

Figure 3.5 SPI Configuration CPHA=0

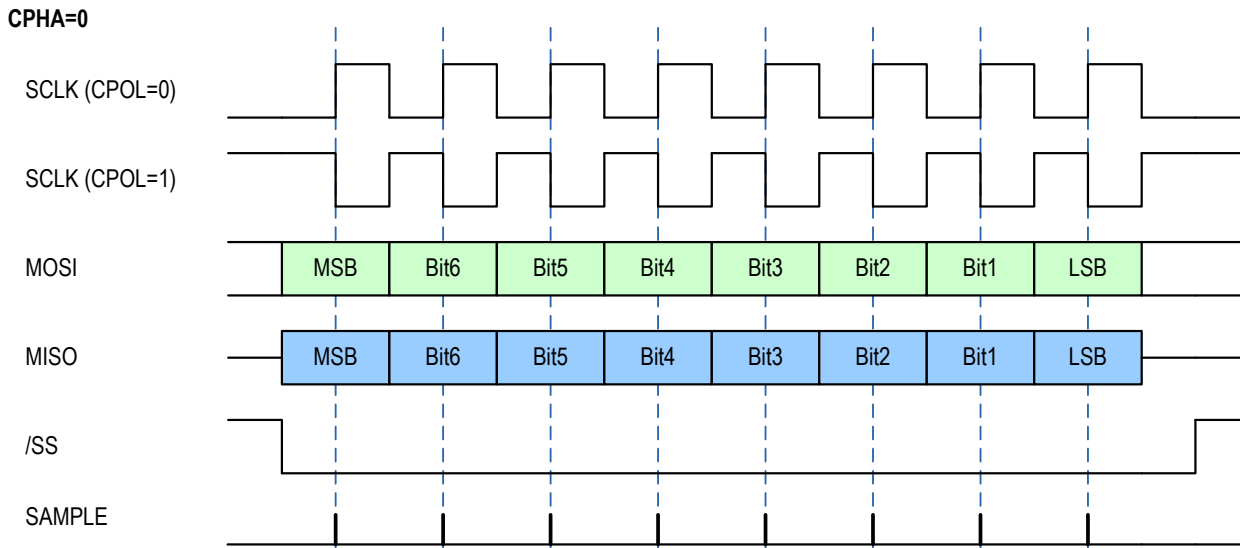
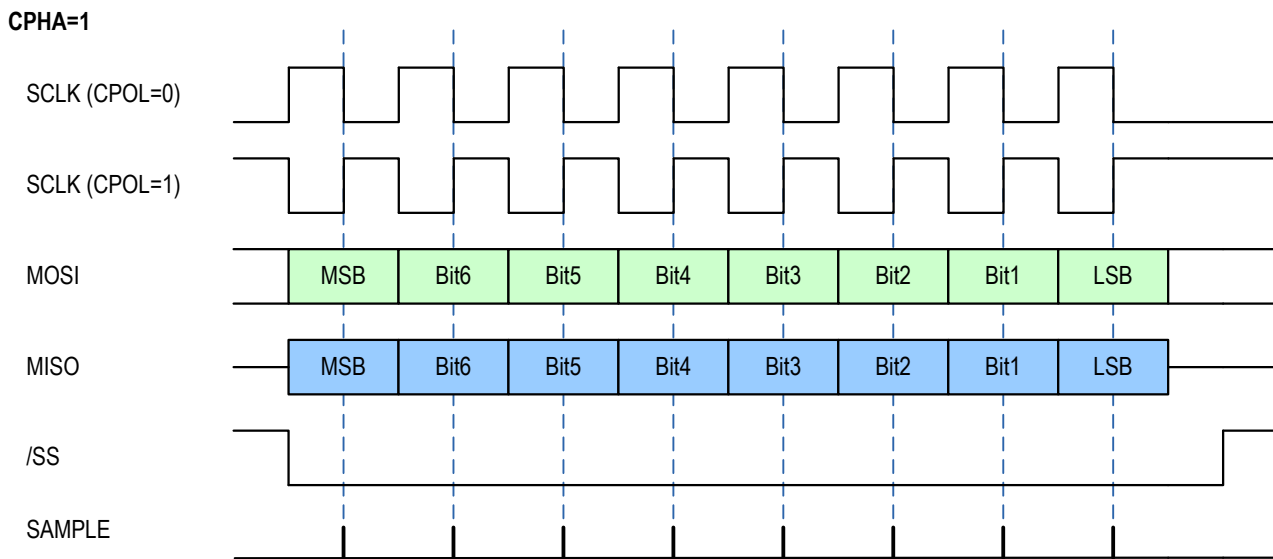

Figure 3.6 SPI Configuration CPHA=1



In SPI Mode, each command except NOP is started as shown in Figure 3.7. After the execution of a command (busy = 0), the expected data can be read as illustrated in Figure 3.8 or if no data are returned by the command, the next command can be sent. The status can be read at any time with the NOP command (see Figure 3.9).

Figure 3.7 SPI Command Request

Command Request

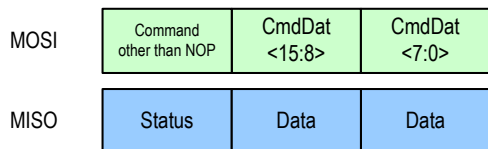

Note: A command request always consists of 3 bytes. If the command is shorter, then it must be completed with 0s. The data on MISO depend on the preceding command.

Figure 3.8 SPI Read Status

Read Status

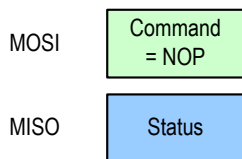

Figure 3.9 SPI Read Data

Read Data

(a) Example: after the completion of a Memory Read command



(b) Example: after the completion of a Full Measurement command (AA_{HEX})

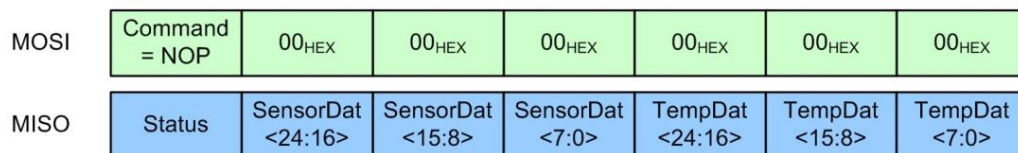

3.5.3 I²C

I²C Mode will be selected if the very first interface activity (after IC power-up) is an I²C command. In I²C Mode, each command is started as shown in Figure 3.10. Only the number of bytes that is needed for the command must be sent. An exception is the I²C High Speed Mode (controlled by the *Slave_Addr* bit field in register 02_{HEX} in Table 3.5) where 3 bytes must always be sent as in SPI Mode. After the execution of a command (busy = 0), the expected data can be read as illustrated in Figure 3.12 or if no data are returned by the command, the next command can be sent. The status can be read at any time as illustrated in Figure 3.11.

Figure 3.10 I²C Command Request

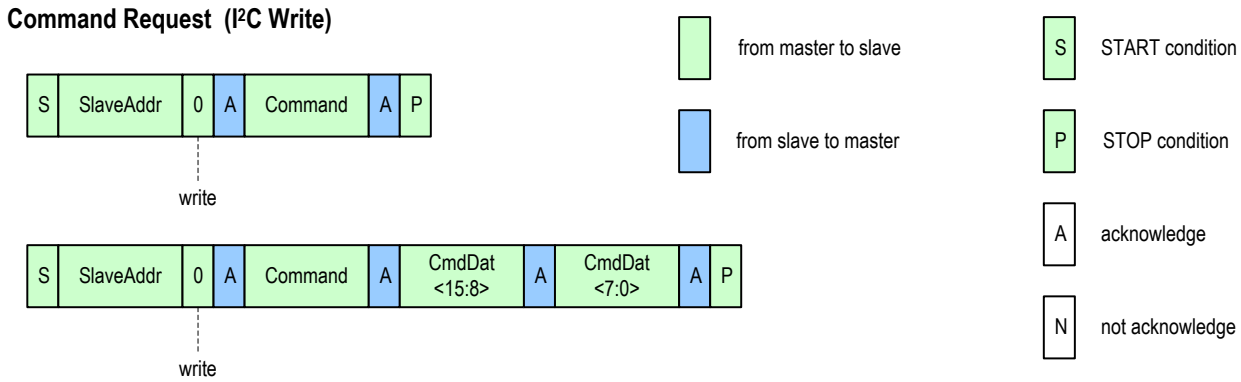

Figure 3.11 I²C Read Status

Read Status (I²C Read)

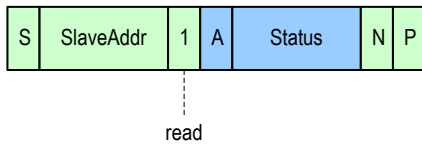
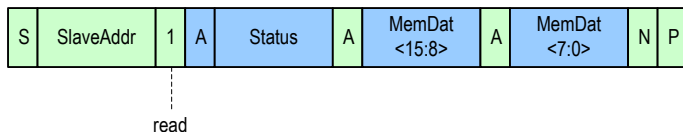

Figure 3.12 I²C Read Data

Read Data (I²C Read)

(a) Example: after the completion of a Memory Read command



(b) Example: after the completion of a Measure command (AA_{HEX})

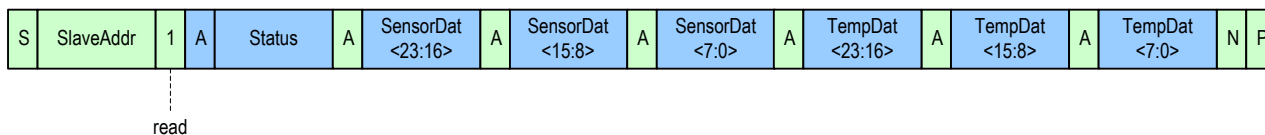

All mandatory I²C-bus protocol features are implemented. Optional features like clock stretching, 10-bit slave address, etc., are not supported by the ZSSC3018's interface.

In I²C High Speed Mode, a command consists of a fixed length of three bytes.

3.6 Memory

In the ZSSC3018, the memory is organized in 16-bit wide registers and can be programmed multiple (at least 1000) times (MTP). There are 57 x 16-bit registers available for customer use. Each register can be re-programmed. Basically, there are two MTP content sectors:

- Customer Use: Accessible by means of regular write operations (40_{HEX} to 79_{HEX}). It contains: the customer ID, interface setup data, measurement setup information, calibration coefficients, etc.
- Renesas Use: Only accessible for write operations by Renesas. The Renesas sector contains specific trim information and is programmed during manufacturing test by Renesas.

3.6.1 Programming Memory

Programming memory is possible with any specified supply voltage level at VDD. The MTP programming voltage itself is generated by means of an integrated charge pump, generating an internal memory programming voltage; no additional external voltage, other than VDD (as specified), needed. A single 16-bit register write will be completed within 16ms after the respective programming command has been sent. After the memory is programmed, it must be read again to verify the validity of the memory contents.

3.6.2 Memory Contents

Table 3.5 MTP Memory Content Assignments

MTP Address	Word / Bit Range	Default Setting	Description	Notes / Explanations
00 _{HEX}	15:0	0000 _{HEX}	Cust_ID0	Customer ID byte 0 (combines with memory word 01 _{HEX} to form customer ID)
01 _{HEX}	15:0	0000 _{HEX}	Cust_ID1	Customer ID byte 1 (combines with memory word 00 _{HEX} to form customer ID)
Interface Configuration				
02 _{HEX}	6:0	000 0000 _{BIN}	Slave_Addr	I ² C slave address; valid range: 00 _{HEX} to 7F _{HEX} (default: 00 _{HEX}). Note: address codes 04 _{HEX} to 07 _{HEX} are reserved for entering the I ² C High Speed Mode
	8:7	00 _{BIN}	INT_setup	Interrupt configuration, EOC pin functionality: 00 End-of-conversion signal 01 0-1 transition if threshold1 (TRSH1) is exceeded and 1-0 transition if threshold1 is underrun again 10 0-1 transition if threshold1 is underrun and 1-0 transition if threshold1 is exceeded again 11 EOC is determined by threshold settings (see section 3.3): If (TRSH1 > TRSH2) then EOC/INT (interrupt level) = 0 if (TRSH1 > MEAS ≥ TRSH2) where MEAS is the conditioned measurement result. Otherwise EOC/INT=1. If (TRSH1 ≤ TRSH2) then EOC/INT = 1 if (TRSH1 ≤ MEAS < TRSH2). Otherwise EOC/INT = 0.
	9	0 _{BIN}	SS_polarity	Determines the polarity of the Slave Select pin (SS) for SPI operation: 0 ⇔ Slave Select is active LOW (SPI and ZSSC3018 are active if SS==0) 1 ⇔ Slave Select is active HIGH (SPI and ZSSC3018 are active if SS==1)
	11:10	00 _{BIN}	CKP_CKE	Clock polarity and clock-edge select—determines polarity and phase of SPI interface clock with the following modes: 00 ⇔ SCLK is low in idle state, data latch with rising edge and data output with falling edge 01 ⇔ SCLK is low in idle state, data latch with falling edge and data output with rising edge 10 ⇔ SCLK is high in idle state, data latch with falling edge and data output with rising edge 11 ⇔ SCLK is high in idle state, data latch with rising edge and data output with falling edge

MTP Address	Word / Bit Range	Default Setting	Description	Notes / Explanations
	14:12	000 _{BIN}	CYC_period	Update period (ZSSC3018 sleep time, except oscillator) in cyclic operation: 000 ⇔ not assigned 001 ⇔ 125ms 010 ⇔ 250ms 011 ⇔ 500ms 100 ⇔ 1000ms 101 ⇔ 2000ms 110 ⇔ 4000ms 111 ⇔ not assigned
	15	0 _{BIN}	SOT_curve	Type / shape of second-order curve correction for the sensor signal. 0 ⇔ parabolic curve 1 ⇔ s-shaped curve
Signal Conditioning Parameters				
03 _{HEX}	15:0	0000 _{HEX}	Offset_S[15:0]	Bits [15:0] of the 24-bit sensor offset correction coefficient Offset_S. (The MSBs of this coefficient including sign are Offset_S[23:16], which is bits [15:8] in 0D _{HEX} .)
04 _{HEX}	15:0	0000 _{HEX}	Gain_S[15:0]	Bits [15:0] of the 24-bit value of the sensor gain coefficient Gain_S. (The MSBs of this coefficient including sign are Gain_S[23:16], which is bits [7:0] in 0D _{HEX} .)
05 _{HEX}	15:0	0000 _{HEX}	Tcg[15:0]	Bits [15:0] of the 24-bit coefficient Tcg for the temperature correction of the sensor gain. (The MSBs of this coefficient including sign are Tcg[23:16], which is bits [15:8] in 0E _{HEX} .)
06 _{HEX}	15:0	0000 _{HEX}	Tco[15:0]	Bits [15:0] of the 24-bit coefficient Tco for temperature correction of the sensor offset. (The MSBs of this coefficient including sign are Tco[23:16], which is bits [7:0] in 0E _{HEX} .)
07 _{HEX}	15:0	0000 _{HEX}	SOT_tco[15:0]	Bits [15:0] of the 24-bit 2 nd order term SOT_tco applied to Tco. (The MSBs of this term including sign are SOT_tco[23:16], which is bits [15:8] in 0F _{HEX} .)
08 _{HEX}	15:0	0000 _{HEX}	SOT_tcg[15:0]	Bits [15:0] of the 24-bit 2 nd order term SOT_tcg applied to Tcg. (The MSBs of this term including sign are SOT_tcg[23:16], which is bits [7:0] in 0F _{HEX} .)
09 _{HEX}	15:0	0000 _{HEX}	SOT_sens[15:0]	Bits [15:0] of the 24-bit 2 nd order term SOT_sens applied to the sensor readout. (The MSBs of this term including sign are SOT_sens[23:16], which is bits [15:8] in 10 _{HEX} .)
0A _{HEX}	15:0	0000 _{HEX}	Offset_T[15:0]	Bits [15:0] of the 24-bit temperature offset correction coefficient Offset_T. (The MSBs of this coefficient including sign are Offset_T[23:16], which is bits [7:0] in 10 _{HEX} .)

MTP Address	Word / Bit Range	Default Setting	Description	Notes / Explanations
0B _{HEX}	15:0	0000 _{HEX}	Gain_T[15:0]	Bits [15:0] of the 24-bit absolute value of the temperature gain coefficient Gain_T. (The MSBs of this coefficient including sign are Gain_T[23:16], which is bits[15:8] in 11 _{HEX} .)
0C _{HEX}	15:0	0000 _{HEX}	SOT_T[15:0]	Bits [15:0] of the 24-bit 2 nd -order term SOT_T applied to the temperature reading. (The MSBs of this coefficient including sign are SOT_T[23:16], which is bit[7:0] in 11 _{HEX} .)
0D _{HEX}	7:0	00 _{HEX}	Gain_S[23:16]	Bits [23:16] including sign for the 24-bit sensor gain correction coefficient Gain_S. (The LSBs of this coefficient are Gain_S[15:0] in register 04 _{HEX} .)
	15:8	00 _{HEX}	Offset_S[23:16]	Bits [23:16] including sign for the 24-bit sensor offset correction coefficient Offset_S. (The LSBs are Offset_S[15:0] in register 03 _{HEX} .)
0E _{HEX}	7:0	00 _{HEX}	Tco[23:16]	Bits [23:16] including sign for the 24-bit coefficient Tco for temperature correction for the sensor offset. (The LSBs are Tco[15:0] in register 06 _{HEX} .)
	15:8	00 _{HEX}	Tcg[23:16]	Bits [23:16] including sign for the 24-bit-wide coefficient Tcg for the temperature correction of the sensor gain. (The LSBs are Tcg[15:0] in register 05 _{HEX} .)
0F _{HEX}	7:0	00 _{HEX}	SOT_tcg[23:16]	Bits [23:16] including sign for the 24-bit 2 nd order term SOT_tcg applied to Tcg. (The LSBs are SOT_tcg[15:0] in register 08 _{HEX} .)
	15:8	00 _{HEX}	SOT_tco[23:16]	Bits [23:16] including sign for the 24-bit 2 nd order term SOT_tco applied to Tco. (The LSBs are SOT_tco[15:0] in register 07 _{HEX} .)
10 _{HEX}	7:0	00 _{HEX}	Offset_T[23:16]	Bits [23:16] including sign for the 24-bit temperature offset correction coefficient Offset_T. (The LSBs are Offset_T[15:0] in register 0A _{HEX} .)
	15:8	00 _{HEX}	SOT_sens[23:16]	Bits [23:16] including sign for the 24-bit 2 nd order term SOT_sens applied to the sensor readout. (The LSBs are SOT_sens[15:0] in register 09 _{HEX} .)
11 _{HEX}	7:0	00 _{HEX}	SOT_T[23:16]	Bits [23:16] including sign for the 24-bit 2 nd -order term SOT_T applied to the temperature reading. (The LSBs are SOT_T[15:0] in register 0C _{HEX} .)
	15:8	00 _{HEX}	Gain_T[23:16]	Bits [23:16] including sign for the 24-bit absolute value of the temperature gain coefficient Gain_T. (The LSBs are Gain_T[15:0] in register 0B _{HEX} .)

MTP Address	Word / Bit Range	Default Setting	Description	Notes / Explanations
1st Measurement Configuration Register (SM_config1)				
12 _{HEX}	2:0	000 _{BIN}	Gain_stage1	Gain setting for the 1 st PREAMP stage with Gain_stage1 ⇔ Gain _{amp1} : 000 ⇔ 6 001 ⇔ 12 010 ⇔ 20 011 ⇔ 30 100 ⇔ 40 101 ⇔ 60 110 ⇔ 80 111 ⇔ 120 (Might affect noise and accuracy specifications depending on sensor setup)
	5:3	000 _{BIN}	Gain_stage2	Gain setting for the 2 nd PREAMP stage with Gain_stage2 ⇔ Gain _{amp2} : 000 ⇔ 1.1 001 ⇔ 1.2 010 ⇔ 1.3 011 ⇔ 1.4 100 ⇔ 1.5 101 ⇔ 1.6 110 ⇔ 1.7 111 ⇔ 1.8
	6	0 _{BIN}	Gain_polarity	Set up the polarity of the sensor bridge's gain (inverting of the chopper) with 0 ⇔ positive (no polarity change) 1 ⇔ negative (180° polarity change)
	10:7	0000 _{BIN} (0100 _{BIN})	Adc_bits	Absolute number of bits for the ADC conversion ADC_bits: 0000 ⇔ 12-bit 0001 ⇔ 13-bit 0010 ⇔ 14-bit 0011 ⇔ 15-bit 0100 ⇔ 16-bit 0101 ⇔ 17-bit 0110 ⇔ 18-bit 0111 to 1111 ⇔ not assigned

MTP Address	Word / Bit Range	Default Setting	Description	Notes / Explanations
	11	0 _{BIN}	AbsV_enable	Enable bit for thermopile input selection (INN connected to AGND, INP connected absolute voltage source) with AbsV_enable: 0 ⇔ absolute voltage input disabled (default) 1 ⇔ absolute voltage input enabled (e.g. for a thermopile)
	14:12	000 _{BIN}	Offset	Differential signal's offset shift in ADC; compensation of x% signal offset: 000 ⇔ no offset compensation 001 ⇔ 6.75% offset 010 ⇔ 12.5% offset 011 ⇔ 19.25% offset 100 ⇔ 25% offset 101 ⇔ 31.75% offset 110 ⇔ 38.5% offset 111 ⇔ 43.25% offset Note: Shift_method (bit 15 below) must be set to 1 to enable the offset shift.
	15	0 _{BIN}	Shift_method	Offset shift method selection: 0 ⇔ No offset shift, Offset (bits[14:12] in 12 _{HEX}) must be set to 000 _{BIN} , GainADC = 1 1 ⇔ Offset shift ADC, GainADC = 2
13 _{HEX}	15:0	0000 _{HEX}	TRSH1[15:0]	Bits [15:0] of the 24-bit interrupt threshold1, TRSH1. (The MSB bits for this threshold are TRSH1[23:16], which is bits [7:0] of register 15 _{HEX} .)
14 _{HEX}	15:0	0000 _{HEX}	TRSH2[15:0]	Bits [15:0] of the 24-bit interrupt threshold2, TRSH2. (The MSB bits for this threshold are TRSH2[23:16], which is bits [15:8] of register 15 _{HEX} .)
15 _{HEX}	7:0	00 _{HEX}	TRSH1[23:16]	Bits [23:16] of the 24-bit interrupt threshold1, TRSH1. (The LSB bits for this threshold are TRSH1[15:0], which is bits [15:0] of register 13 _{HEX} .)
	15:8	00 _{HEX}	TRSH2[23:16]	Bits [23:16] of the 24-bit interrupt threshold2, TRSH2. (The LSB bits for this threshold are TRSH2[15:0], which is bits [15:0] of register 14 _{HEX} .)

MTP Address	Word / Bit Range	Default Setting	Description	Notes / Explanations
2nd Measurement Configuration Register (SM_config2)				
16 _{HEX}	2:0	000 _{BIN}	Gain_stage1	Gain setting for the 1 st PREAMP stage with Gain_stage1 ⇔ Gain _{amp1} : 000 ⇔ 6 001 ⇔ 12 010 ⇔ 20 011 ⇔ 30 100 ⇔ 40 101 ⇔ 60 110 ⇔ 80 111 ⇔ 120 (Might affect noise and accuracy specifications depending on sensor setup)
	5:3	000 _{BIN}	Gain_stage2	Gain setting for the 2 nd PREAMP stage with Gain_stage2 ⇔ Gain _{amp2} : 000 ⇔ 1.1 001 ⇔ 1.2 010 ⇔ 1.3 011 ⇔ 1.4 100 ⇔ 1.5 101 ⇔ 1.6 110 ⇔ 1.7 111 ⇔ 1.8
	6	0 _{BIN}	Gain_polarity	Set up the polarity of the sensor bridge's gain (inverting of the chopper) with 0 ⇔ positive (no polarity change) 1 ⇔ negative (180° polarity change)
	10:7	0000 _{BIN} (0100 _{BIN})	Adc_bits	Absolute number of bits for the ADC conversion ADC_bits: 0000 ⇔ 12-bit 0001 ⇔ 13-bit 0010 ⇔ 14-bit 0011 ⇔ 15-bit 0100 ⇔ 16-bit 0101 ⇔ 17-bit 0110 ⇔ 18-bit 0111 to 1111 ⇔ not assigned

MTP Address	Word / Bit Range	Default Setting	Description	Notes / Explanations
	11	0 _{BIN}	AbsV_enable	Enable bit for thermopile input selection (INN connected to AGND, INP connected absolute voltage source) with AbsV_enable: 0 ⇔ absolute voltage input disabled (default) 1 ⇔ absolute voltage input enabled (e.g. for a thermopile)
	14:12	000 _{BIN}	Offset	Differential signal's offset shift in ADC; compensation of x% signal offset: 000 ⇔ no offset compensation 001 ⇔ 6.75% offset 010 ⇔ 12.5% offset 011 ⇔ 19.25% offset 100 ⇔ 25% offset 101 ⇔ 31.75% offset 110 ⇔ 38.5% offset 111 ⇔ 43.25% offset Note: <i>Shift_method</i> (bit 15 below) must be set to 1 to enable the offset shift.
	15	0 _{BIN}	Shift_method	Offset shift method selection: 0 ⇔ No offset shift, Offset (bits[14:12] in 12 _{HEX}) must be set to 000 _{BIN} , GainADC = 1 1 ⇔ Offset shift ADC, GainADC = 2
Post-Calibration Offset Correction Coefficients				
17 _{HEX}	15:0	0000 _{HEX}	SENS_Shift[15:0]	Bits [15:0] of the post-calibration sensor offset shift coefficient SENS_Shift. (The MSB bits of SENS_Shift are bits [7:0] of register 19 _{HEX} .)
18 _{HEX}	15:0	0000 _{HEX}	T_Shift[15:0]	Bits [15:0] of the post-calibration temperature offset shift coefficient T_Shift. (The MSB bits of T_Shift are bits [15:8] of register 19 _{HEX} .)
19 _{HEX}	7:0	00 _{HEX}	SENS_Shift[23:16]	Bits [23:16] of the post-calibration sensor offset shift coefficient SENS_Shift. (The LSB bits of SENS_Shift are in register 17 _{HEX} .)
	15:8	00 _{HEX}	T_Shift[23:16]	Bits [23:16] of the post-calibration temperature offset shift coefficient T_Shift. (The LSB bits of T_Shift are in register 18 _{HEX} .)
Free Memory – Arbitrary Use				
20 _{HEX}	15:0	0000 _{HEX}		Not assigned (e.g., can be used for Cust_IDx customer identification number)
21 _{HEX}	15:0	0000 _{HEX}		Not assigned (e.g., can be used for Cust_IDx customer identification number)
...				...

MTP Address	Word / Bit Range	Default Setting	Description	Notes / Explanations
37 _{HEX}	15:0	0000 _{HEX}		Not assigned (e.g., can be used for Cust_IDx customer identification number)
38 _{HEX}	15:0	0000 _{HEX}		Not assigned (e.g., can be used for Cust_IDx customer identification number)
39 _{HEX}	15:0	-	Checksum	Checksum generated for whole memory through a linear feedback shift register (LFSR); signature is checked with power-up to ensure memory content integrity

The memory integrity checksum (referred to as *CRC*) is generated through a linear feedback shift register with the polynomial:

$$g(x) = x^{16} + x^{15} + x^2 + 1 \quad \text{with the initialization value: FFFF}_{\text{HEX}}.$$

If the CRC is valid, then the “Memory Error” status bit is set to 0.

3.7 Calibration Sequence

Calibration essentially involves collecting raw signal and temperature data from the sensor-ZSSC3018 system for different known sensor-element values (i.e., a resistive bridge or an absolute voltage source) and temperatures. This raw data can then be processed by the calibration master (assumed to be the user's computer), and the calculated calibration coefficients can then be written to on-chip memory.

Here is a brief overview of the three main steps involved in calibrating the ZSSC3018.

Assigning a unique identification to the ZSSC3018. This identification is written to shadow RAM and programmed in MTP memory. This unique identification can be stored in the two 16-bit registers dedicated to the customer ID (00_{HEX} and 01_{HEX}; see Table 3.5). It can be used as an index into a database stored on the calibration computer. This database will contain all the raw values of the connected sensor-element readings and temperature readings for that part, as well as the known sensor-element measurand conditions and temperature to which the sensor-element was exposed.

Data collection. Data collection involves getting uncorrected or raw data from the external sensor at different known measurand values and temperatures. Then this data is stored on the calibration computer using the unique identification of the device as the index to the database.

Coefficient calculation and storage in MTP memory. After enough data points have been collected to calculate all the desired coefficients, the coefficients can be calculated by the calibrating computer. Then the coefficients can be programmed to the MTP memory.

Result. The sensor signal and the characteristic temperature effect on output will be linearized according to the setup-dependent maximum output range.

It is essential to perform the calibration with a fixed programming setup during the data collection phase. In order to prevent any accidental incorrect processing, it is further recommended that the MTP memory setup is kept stable during the whole calibration process as well as in the subsequent operation. A ZSSC3018 calibration only fits the setup used during its calibration. Changes of functional parameters after a successful calibration can decrease the precision and accuracy performance of the ZSSC3018 as well as of the whole application.

Note: The ZSSC3018 supports operation with different sensor setups via the *SM_config1* and *SM_config2* registers. However, only one calibration coefficient set is supported. Therefore, either an alternative ZSSC3218-external signal calibration using the alternate *SM_config* settings must also be performed to ensure that the programmed SSC coefficients are valid for both setups, or a full reprogramming of the SSC coefficients must be performed each time the sensor setup is changed. The selection of the external sensor setup (i.e., the AFE configuration) can be done with the interface commands B0_{HEX} and B1_{HEX}.

3.7.1 Calibration Step 1 – Assigning Unique Identification

Assign a unique identification number to the ZSSC3018 by using the memory write command (40_{HEX} + data and 41_{HEX} + data; see Table 3.1 and Table 3.5) to write the identification number to *Cust_ID0* at memory address 00_{HEX} and *Cust_ID1* at address 01_{HEX} as described in section 3.6.1. These two 16-bit registers allow for more than 4 billion unique devices.

3.7.2 Calibration Step 2 – Data Collection

The number of unique points (measurand and/or temperature) at which calibration must be performed generally depends on the requirements of the application and the behavior of the sensor in use. The minimum number of points required is equal to the number of correction coefficients to be corrected with a minimum of three different temperatures at three different sensor values. For a full calibration resulting in values for all 7 possible (external) sensor coefficients and 3 possible temperature coefficients, a minimum of 7 pairs of sensor with temperature measurements must be collected.

Within this minimum field of 3 measurand measurements x 3 temperature measurements, data must be collected for the specific value pairs (at known conditions) and then processed to calculate the coefficients. In order to obtain the potentially best and most robust coefficients, it is recommended that measurement pairs (temperature vs. measurand) be collected at the outer corners of the intended operation range or at least at points that are located far apart. It is also essential to provide highly precise reference values as nominal, expected values. The measurement precision of the external calibration-measurement equipment should be ten times more accurate than the expected ZSSC3018 output accuracy after calibration in order to avoid accuracy losses caused by the nominal reference values (e.g., measurand signal and temperature deviations).

Note: The coefficients *SENS_shift* and *T_shift* must not be determined during this calibration step.
Strong recommendation: Set these coefficients to zero until after initial calibration.

Note: An appropriate selection of measurement pairs can significantly improve the overall system performance.

The determination of the measurand-related coefficients will use all of the measurement pairs. For the temperature-related correction coefficients, 3 of the measurement pairs (at three different temperatures) will be used.

Note: There is an inherent redundancy in the 7 sensor-related and 3 temperature-related coefficients. Since the temperature is a necessary output (which also needs correction), the temperature-related information is mathematically separated, which supports faster and more efficient DSP calculations during the normal usage of the sensor-ZSSC3018 system. The recommended approach for data collection is to make use of the raw-measurement commands described in Table 3.2:

For external sensor values, either of the following commands can be used depending on the user's requirements:

- $A2_{\text{HEX}} + 0000_{\text{HEX}}$: Single sensor measurement for which the configuration register will be loaded from the *SM_config1* register (12_{HEX} in MTP); preprogramming the measurement setup in the MTP is required.
Note: *SM_config1* is the default configuration. Alternatively, *SM_config2* (16_{HEX} in MTP) can be used by first sending the command $B1_{\text{HEX}}$ (see section 3.7.5).
- $A3_{\text{HEX}} + \text{ssss}_{\text{HEX}}$: Single sensor measurement for which the *SM_config* configuration register (Gain, ADC, Offset, etc.) will be loaded as the user's configuration ssss_{HEX} and must be provided externally via the interface as the data part of this command.

For temperature values either of the following commands can be used depending on the user's requirements:

- $A6_{\text{HEX}} + 0000_{\text{HEX}}$: Single temperature measurement for which the configuration register will be loaded from an internal temperature configuration register (preprogrammed by Renesas in MTP); preprogramming of the respective configuration is done by Renesas prior to ZSSC3018 delivery. This is the recommended approach for temperature data collection.
- $A7_{\text{HEX}} + \text{ssss}_{\text{HEX}}$: Single temperature measurement for which the configuration register (Gain, ADC, Offset, etc.) will be loaded as ssss_{HEX} , which must be provided externally via the interface as the data part of this command. In this case, the format and purpose of these configuration bits must be according to the definitions for *SM_config* and valid for temperature measurement (bits [15:12] will be ignored).

3.7.3 Calibration Step 3a) – Coefficient Calculations

The math to perform the coefficient calculation is complicated and will not be discussed in detail. There is a brief overview in the next section. Renesas will provide software (DLLs) to perform the coefficient calculation (external to the sensor-ZSSC3018 system) based on auto-zero corrected values. After the coefficients are calculated, the final step is to write them to the MTP memory of the ZSSC3018.

3.7.4 Calibration Step 3b) – Post-Calibration Offset Correction

There are two special SSC-coefficients, *SENS_shift* and *T_shift*. Normally, these coefficients must be set to zero during the initial sensor calibration. The primary purpose of these two coefficients is to cancel additional offset shifts that could occur during or after final sensor assembly, e.g. if a respective sensor is finally placed and soldered on an application board.

If the final sensor assembly induced any kind of offset (on either the temperature or the external sensor signal), the respective influence can be directly compensated via the *SENS_shift* and *T_shift* coefficients without the need to change the original SSC coefficient set. However, this post-calibration offset correction must be done under known ambient conditions (i.e., sensor measurand and/or temperature).

3.7.5 SSC Measurements

After the completion of the calibration procedure, linearized external sensor and temperature readings can be obtained using these commands: AA_{HEX} to AF_{HEX}.

Typically, only one external sensor in a single analog configuration (setup in *SM_config1*, MTP register 12_{HEX}) will be used. However, the ZSSC3018 can support a second analog configuration that is set up in *SM_config2*, MTP register 16_{HEX}. This might be useful in cases where only one sensor-ZSSC3218 pair must support the measurand ranges for two different external sensors that have different precisions, required amplification, and sensor offset.

If a respective switching between setups is to be performed, the SSC coefficients for the alternate external sensor must be handled with one of the following methods:

The programmed SSC coefficients are not used for the alternate external sensor. The ZSSC3218 performs only a one-to-one transfer, i.e. no effective digital SSC correction – only a transfer of the auto-zero corrected raw ADC readings to the ZSSC3218 output without any scaling, etc.

The coefficients are re-programmed each time the analog setup is changed.

SM_config1 is selected as analog setup register by default, so no specific activation is needed if only *SM_config1* is used. If *SM_config2* will also be used, the activation command B1_{HEX} must be sent once prior to the measurement requests. To switch to using *SM_config1*, the activation command B0_{HEX} must be sent prior to use. This respective activation must be refreshed after any power-on-reset or RES pin reset.

3.8 The Calibration Math

3.8.1 Bridge Signal Compensation

The saturation check in the ZSSC3018 detects saturation effects of the internal calculation steps, allowing the final correction output to still be determined. It is possible to get potentially useful signal conditioning results that have had an intermediate saturation during the calculations. These cases are detectable by observing the status bit[0] for each measurement result. Details about the saturation limits and the valid ranges for values are provided in the following equations.

The calibration math description assumes a calculation with integer numbers. The description is numerically correct concerning values, dynamic range, and resolution.

SOT_curve selects whether second-order equations compensate for sensor nonlinearity with a parabolic or S-shaped curve. The parabolic compensation is recommended for most sensor types.

For the following equations, the terms are as follows:

<i>S</i>	Corrected sensor reading output via I ² C or SPI; range [0 _{HEX} to FFFFF _{HEX}]
<i>S_Raw</i>	Raw sensor reading from ADC after AZ correction; range [-7FFFF _{HEX} , 7FFFF _{HEX}]
<i>Gain_S</i>	Sensor gain term; range [-7FFFF _{HEX} , 7FFFF _{HEX}]
<i>Offset_S</i>	Sensor offset term; range [-7FFFF _{HEX} , 7FFFF _{HEX}]
<i>Tcg</i>	Temperature coefficient gain term; range [-7FFFF _{HEX} , 7FFFF _{HEX}]
<i>Tco</i>	Temperature coefficient offset term; range [-7FFFF _{HEX} , 7FFFF _{HEX}]
<i>T_Raw</i>	Raw temperature reading after AZ correction; range [-7FFFF _{HEX} , 7FFFF _{HEX}]
<i>SOT_tcg</i>	Second-order term for <i>Tcg</i> non-linearity; range [-7FFFF _{HEX} , 7FFFF _{HEX}]
<i>SOT_tco</i>	Second-order term for <i>Tco</i> non-linearity; range [-7FFFF _{HEX} , 7FFFF _{HEX}]
<i>SOT_sens</i>	Second-order term for sensor non-linearity; range [-7FFFF _{HEX} , 7FFFF _{HEX}]
<i>SENS_shift</i>	Post-calibration, post-assembly sensor offset shift; range [-7FFFF _{HEX} , 7FFFF _{HEX}]
...	Absolute value
[...] _{ll} ^{ul}	Bound/saturation number range from <i>ll</i> to <i>ul</i> , over/under-flow is reported as saturation in the status byte

The correction formula for the differential signal reading is represented as a two-step process depending on the *SOT_curve* setting.

Equations for the parabolic *SOT_curve* setting (*SOT_curve* = 0):

Simplified:

$$K_1 = 2^{23} + \frac{T_Raw}{2^{23}} * \left(\frac{4 * SOT_tcg}{2^{23}} * T_Raw + 4 * Tcg \right) \tag{1}$$

$$K_2 = 4 * Offset_S + S_Raw + \frac{T_Raw}{2^{23}} * \left(\frac{4 * SOT_tco}{2^{23}} * T_Raw + 4 * Tco \right) \tag{2}$$

$$Z_{SP} = \frac{4 * Gain_S}{2^{23}} * \frac{K_1}{2^{23}} * K_2 + 2^{23} \quad (\text{delimited to positive number range}) \tag{3}$$

$$S = \frac{Z_{BP}}{2^{23}} * \left(\frac{4 * SOT_sens}{2^{23}} * Z_{SP} + 2^{23} \right) + SENS_shift \tag{4}$$

(delimited to positive number range)

Complete:

$$K_1 = \left[2^{23} + \left[\frac{T_Raw}{2^{23}} * \left[\left[\frac{SOT_tcg}{2^{21}} * T_Raw \right]_{-2^{25}}^{2^{25}-1} + 4 * Tcg \right]_{-2^{25}}^{2^{25}-1} \right]_{-2^{25}}^{2^{25}-1} \right]_{-2^{25}}^{2^{25}-1} \quad (5)$$

$$K_2 = \left[4 * Offset_S + \left[S_Raw + \left[\frac{T_Raw}{2^{23}} * \left[\left[\frac{SOT_tco}{2^{21}} * T_Raw \right]_{-2^{25}}^{2^{25}-1} + 4 * Tco \right]_{-2^{25}}^{2^{25}-1} \right]_{-2^{25}}^{2^{25}-1} \right]_{-2^{25}}^{2^{25}-1} \right]_{-2^{25}}^{2^{25}-1} \quad (6)$$

$$Z_{SP} = \left[\left[\frac{Gain_S}{2^{21}} * \left[\frac{K_1}{2^{23}} * K_2 \right]_{-2^{25}}^{2^{25}-1} + 2^{23} \right]_{-2^{25}}^{2^{25}-1} \right]_0^{2^{25}-1} \quad (7)$$

$$B = \left[\frac{Z_{SP}}{2^{23}} * \left[\left[\frac{SOT_sens}{2^{21}} * Z_{BP} \right]_{-2^{25}}^{2^{25}-1} + 2^{23} \right]_{-2^{25}}^{2^{25}-1} + SENS_shift \right]_0^{2^{24}-1} \quad (8)$$

Equations for the S-shaped SOT_curve setting (SOT_curve = 1):

Simplified:

$$Z_{SS} = \frac{4 * Gain_S}{2^{23}} * \frac{K_1}{2^{23}} * K_2 \quad (9)$$

$$S = \frac{Z_{SS}}{2^{23}} * \left(\frac{4 * SOT_sens}{2^{23}} * |Z_{SS}| + 2^{23} \right) + 2^{23} + SENS_shift \quad (\text{delimited to positive number range}) \quad (10)$$

Complete:

$$Z_{SS} = \left[\frac{Gain_S}{2^{21}} * \left[\frac{K_1}{2^{23}} * K_2 \right]_{-2^{25}}^{2^{25}-1} \right]_{-2^{25}}^{2^{25}-1} \quad (11)$$

$$S = \left[\left[\frac{Z_{SS}}{2^{23}} * \left[\left[\frac{SOT_sens}{2^{21}} * |Z_{SS}| \right]_{-2^{25}}^{2^{25}-1} + 2^{23} \right]_{-2^{25}}^{2^{25}-1} + 2^{23} + SENS_shift \right]_{-2^{25}}^{2^{25}-1} \right]_0^{2^{24}-1} \quad (12)$$

3.8.2 Temperature Signal Compensation

Temperature is measured internally. Temperature correction contains both linear gain and offset terms as well as a second-order term to correct for any nonlinearities. For temperature, second-order compensation for nonlinearity is always parabolic.

The correction formula is best represented as a two-step process as follows:

Simplified:

$$Z_T = \frac{4 * Gain_T}{2^{23}} * (T_Raw + 4 * Offset_T) + 2^{23} \quad (\text{delimited to positive number range}) \quad (13)$$

$$T = \frac{Z_T}{2^{23}} * \left(\frac{4 * SOT_T}{2^{23}} * Z_T + 2^{23} \right) + T_Shift \quad (\text{delimited to positive number range}) \quad (14)$$

Complete:

$$Z_T = \left[\left[\frac{Gain_T}{2^{21}} * [T_Raw + 4Offset_T]_{-2^{25}}^{2^{25}-1} \right]_{-2^{25}}^{2^{25}-1} + 2^{23} \right]_0^{2^{25}-1} \quad (15)$$

$$T = \left[\frac{Z_T}{2^{23}} * \left[\left[\frac{SOT_T}{2^{21}} * Z_T \right]_{-2^{25}}^{2^{25}-1} + 2^{23} \right]_{-2^{25}}^{2^{25}-1} + T_Shift \right]_0^{2^{24}-1} \quad (16)$$

Where

- T* Corrected temperature sensor reading output via I²C or SPI; range [0_{HEX} to FFFFFFF_{HEX}]
- Gain_T* Gain coefficient for temperature; range [-7FFFFFF_{HEX} to 7FFFFFF_{HEX}]
- T_Raw* Raw temperature reading after AZ correction; range [-7FFFFFF_{HEX} to 7FFFFFF_{HEX}]
- Offset_T* Offset coefficient for temperature; range [-7FFFFFF_{HEX} to 7FFFFFF_{HEX}]
- SOT_T* Second-order term for temperature source non-linearity; range [-7FFFFFF_{HEX} to 7FFFFFF_{HEX}]
- T_Shift* Shift for post-calibration/post-assembly offset compensation; range [-7FFFFFF_{HEX} to 7FFFFFF_{HEX}]

3.8.3 Measurement Output Data Format

The data format and bit assignment of the raw measurement and SSC-corrected outputs of the ZSSC3018 are defined in the following tables. Any ADC measurement and SSC calculation output is formatted as a 24-bit wide data word, regardless on the effective ADC resolution used. The values are either in two's complement or sign-absolute format.

Table 3.6 Measurement Results of ADC Raw Measurement Request (Two's Complement)

Bit	23	22	21	20	...	1	0
Meaning, Weighting	-2^0	2^{-1}	2^{-2}	2^{-3}	...	2^{-22}	2^{-23}

Table 3.7 Calibration Coefficients (Factors and Summands) in Memory (Sign-Magnitude)

Bit	23	22	21	20	...	1	0
Meaning, weighting	0=positive 1=negative	2^1	2^0	2^{-1}	...	2^{-20}	2^{-21}

Table 3.8 Output Results from SSC-Correction Math or DSP—Sensor and Temperature

Bit	23	22	21	20	...	1	0
Meaning, weighting	2^0	2^{-1}	2^{-2}	2^{-3}	...	2^{-22}	2^{-23}

Table 3.9 Interrupt Thresholds TRSH1 and TRSH2—Format as for SSC-Correction Math Output

Bit	23	22	21	20	...	1	0
Meaning, weighting	2^0	2^{-1}	2^{-2}	2^{-3}	...	2^{-22}	2^{-23}

4. Packaging Dimensions and Pin Assignments

The ZSSC3018 is available as die or as a 24-PQFN. See Table 4.1 for detailed 24-PQFN package dimensions and Table 4.2 for pin descriptions.

For die and pad dimensions refer to the ZSSC3018 Technical Brief – Die and Pad Dimensions.

Figure 4.1 General 24-PQFN Package Dimensions

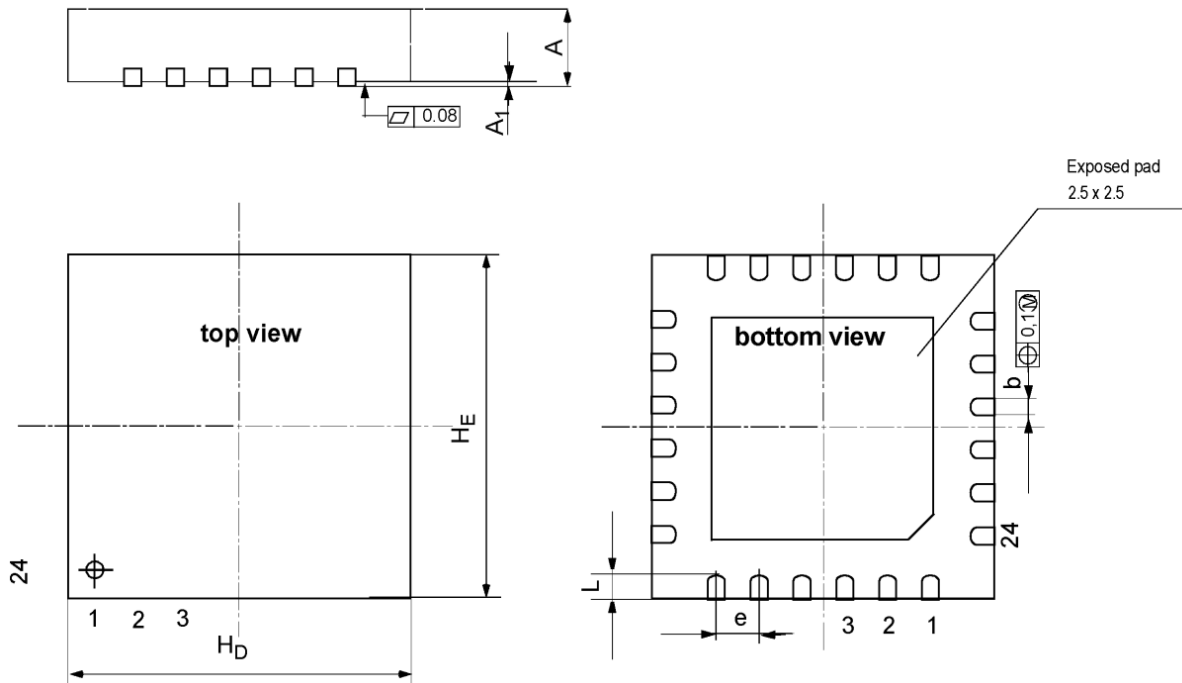

Table 4.1 24-PQFN Dimensions (4 x 4 mm)

Dimension Limit	MIN	NOM	MAX
A	0.80		0.90
A ₁	0.00		0.05
b	0.20		0.30
e		0.50	
H _D	3.90		4.10
H _E	3.90		4.10
L	0.30		0.50

Table 4.2 Pin Assignments 24-PQFN

Note: In the following table, “n.c.” stands for not connected / no connection required / not bonded.

Pin No.	Name	Direction	Type	Description
1	TEST1	-	–	Do not connect.
2	RES	In	Digital	ZSSC3018 reset (low active, internal pull-up).
3	Vddb	Out	Analog	Positive external bridge-sensor supply.
4	INN	In	Analog	Negative sensor signal (or sensor ground for absolute voltage-source sensors).
5	EOC	Out	Digital	End of conversion or interrupt output.
6	MISO	Out	Digital	Data output for SPI.
7	TEST2	-	–	Do not connect.
8	n.c.	-	–	–
9	n.c.	-	–	–
10	n.c.	-	–	–
11	n.c.	-	–	–
12	SCLK/SCL	In	Digital	Clock input for SPI/I ² C.
13	MOSI/SDA	In/Out	Digital	Data input for SPI; data in/out for I ² C.
14	VSSB	Out	Analog	Negative external bridge-sensor supply (sensor ground).
15	INP	In	Analog	Positive sensor signal.
16	TEST5	-	–	Do not connect.
17	SS	In	Digital	Slave select for SPI.
18	TEST4	-	–	Do not connect.
19	TEST3	-	–	Do not connect.
20	n.c.	-	–	–
21	n.c.	-	–	–
22	VDD	In	Supply	IC positive supply voltage for the ZSSC3018.
23	n.c.	-	–	–
24	VSS	In	Supply	Ground reference voltage signal.
25	Exposed pad	-	–	Do not connect electrically.

5. Quality and Reliability

The ZSSC3018 is available as a qualified IC version for consumer and industrial market applications. All data specified parameters are guaranteed if not stated otherwise.

6. Ordering Information

Product Sales Code	Description	Package
ZSSC3018BA3W	ZSSC3018 24-PQFN – temperature range: –40°C to +125°C	7" Reel
ZSSC3018BA1B	ZSSC3018 Die – temperature range: –40°C to +125°C	Unsawn on Wafer (304µm)
ZSSC3018BA2B	ZSSC3018 Die – temperature range: –40°C to +125°C	Unsawn on Wafer (725µm)
ZSSC3018BA2C	ZSSC3018 Die – temperature range: –40°C to +125°C	Sawn on Wafer Frame
ZSSC3018BA2D	ZSSC3018 Die – temperature range: –40°C to +125°C	Sawn in Waffle Pack (for sampling only)
ZSSC3018KITV1P0	Modular ZSSC3018 SSC Evaluation Kit including three interconnecting boards, five ZSSC3018 24-PQFN samples, and cable. Software is available for download on www.IDT.com/ZSSC3018 .	

7. Related Documents

Visit the ZSSC3018 product page at www.IDT.com/ZSSC3018 or contact your nearest sales office for ordering information or the latest version of this document and related documents.

8. Glossary

Term	Description
A2D	Analog-to-Digital
ACK	Acknowledge (interface's protocol indicator for successful data/command transfer)
ADC	Analog-to-Digital Converter or Conversion
ALU	Arithmetic Logic Unit
AZ	Auto-Zero (unspecific)
AZSM	Auto-Zero Measurement for (external) Sensor Path
AZTM	Auto-Zero Measurement for Temperature Path
Au	Gold
CLK	Clock
Cu	Copper
DAC	Digital-to-Analog Conversion or Converter
DF	Data Fetch (command type)
DSP	Digital Signal Processor (digital configuration, calibration, calculation, communication unit)

Term	Description
EOC	End of Conversion
FSO	Full Scale Output (value in percent relative to the ADC maximum output code; resolution dependent)
LSB	Least Significant Bit
LFSR	Linear Feedback Shift Register
MR	Measurement Request (command type)
MSB	Most Significant Bit
MTP	Multiple-Time Programmable Memory
NACK	Not Acknowledge (interface's protocol indicator for unsuccessful data/command transfer)
POR	Power-on Reset
PreAmp	Preamplifier
PSRR	Power Supply Disturbance Rejection Ratio
SM	Signal Measurement
SOT	Second-Order Term
TC	Temperature Coefficient (of a resistor or the equivalent bridge resistance)
TM	Temperature Measurement

9. Revision History

Date	Description
September 8, 2020	Update for order codes in section 6. Changed to Renesas branding
January 10, 2017	Updates for product sales codes and addition of new product sales code for die samples in waffle pack.
November 14, 2016	Correction for typical sensor system accuracy specification on page 1 and in Table 1.4 from $\pm 0.01\%$ FSO to $\pm 0.10\%$ FSO. Addition of die as a delivery option. Revision of name for ZMDI-test pins in Table 4.2. Updates for formatting for text and figures.
July 18, 2016	Correction for package dimensions in section 4.
January 26, 2016	Changed to IDT branding. Revision reference is now the document release date.
December 10, 2015 (Rev. 1.01)	Update for order codes in section 6. Correction for Figure 3.12. Minor edits for clarity.
November 12, 2015 (Rev. 1.00)	First release.

Notice

1. Descriptions of circuits, software and other related information in this document are provided only to illustrate the operation of semiconductor products and application examples. You are fully responsible for the incorporation or any other use of the circuits, software, and information in the design of your product or system. Renesas Electronics disclaims any and all liability for any losses and damages incurred by you or third parties arising from the use of these circuits, software, or information.
2. Renesas Electronics hereby expressly disclaims any warranties against and liability for infringement or any other claims involving patents, copyrights, or other intellectual property rights of third parties, by or arising from the use of Renesas Electronics products or technical information described in this document, including but not limited to, the product data, drawings, charts, programs, algorithms, and application examples.
3. No license, express, implied or otherwise, is granted hereby under any patents, copyrights or other intellectual property rights of Renesas Electronics or others.
4. You shall be responsible for determining what licenses are required from any third parties, and obtaining such licenses for the lawful import, export, manufacture, sales, utilization, distribution or other disposal of any products incorporating Renesas Electronics products, if required.
5. You shall not alter, modify, copy, or reverse engineer any Renesas Electronics product, whether in whole or in part. Renesas Electronics disclaims any and all liability for any losses or damages incurred by you or third parties arising from such alteration, modification, copying or reverse engineering.
6. Renesas Electronics products are classified according to the following two quality grades: "Standard" and "High Quality". The intended applications for each Renesas Electronics product depends on the product's quality grade, as indicated below.

"Standard": Computers; office equipment; communications equipment; test and measurement equipment; audio and visual equipment; home electronic appliances; machine tools; personal electronic equipment; industrial robots; etc.

"High Quality": Transportation equipment (automobiles, trains, ships, etc.); traffic control (traffic lights); large-scale communication equipment; key financial terminal systems; safety control equipment; etc.

Unless expressly designated as a high reliability product or a product for harsh environments in a Renesas Electronics data sheet or other Renesas Electronics document, Renesas Electronics products are not intended or authorized for use in products or systems that may pose a direct threat to human life or bodily injury (artificial life support devices or systems; surgical implantations; etc.), or may cause serious property damage (space system; undersea repeaters; nuclear power control systems; aircraft control systems; key plant systems; military equipment; etc.). Renesas Electronics disclaims any and all liability for any damages or losses incurred by you or any third parties arising from the use of any Renesas Electronics product that is inconsistent with any Renesas Electronics data sheet, user's manual or other Renesas Electronics document.
7. No semiconductor product is absolutely secure. Notwithstanding any security measures or features that may be implemented in Renesas Electronics hardware or software products, Renesas Electronics shall have absolutely no liability arising out of any vulnerability or security breach, including but not limited to any unauthorized access to or use of a Renesas Electronics product or a system that uses a Renesas Electronics product. RENESAS ELECTRONICS DOES NOT WARRANT OR GUARANTEE THAT RENESAS ELECTRONICS PRODUCTS, OR ANY SYSTEMS CREATED USING RENESAS ELECTRONICS PRODUCTS WILL BE INVULNERABLE OR FREE FROM CORRUPTION, ATTACK, VIRUSES, INTERFERENCE, HACKING, DATA LOSS OR THEFT, OR OTHER SECURITY INTRUSION ("Vulnerability Issues"). RENESAS ELECTRONICS DISCLAIMS ANY AND ALL RESPONSIBILITY OR LIABILITY ARISING FROM OR RELATED TO ANY VULNERABILITY ISSUES. FURTHERMORE, TO THE EXTENT PERMITTED BY APPLICABLE LAW, RENESAS ELECTRONICS DISCLAIMS ANY AND ALL WARRANTIES, EXPRESS OR IMPLIED, WITH RESPECT TO THIS DOCUMENT AND ANY RELATED OR ACCOMPANYING SOFTWARE OR HARDWARE, INCLUDING BUT NOT LIMITED TO THE IMPLIED WARRANTIES OF MERCHANTABILITY, OR FITNESS FOR A PARTICULAR PURPOSE.
8. When using Renesas Electronics products, refer to the latest product information (data sheets, user's manuals, application notes, "General Notes for Handling and Using Semiconductor Devices" in the reliability handbook, etc.), and ensure that usage conditions are within the ranges specified by Renesas Electronics with respect to maximum ratings, operating power supply voltage range, heat dissipation characteristics, installation, etc. Renesas Electronics disclaims any and all liability for any malfunctions, failure or accident arising out of the use of Renesas Electronics products outside of such specified ranges.
9. Although Renesas Electronics endeavors to improve the quality and reliability of Renesas Electronics products, semiconductor products have specific characteristics, such as the occurrence of failure at a certain rate and malfunctions under certain use conditions. Unless designated as a high reliability product or a product for harsh environments in a Renesas Electronics data sheet or other Renesas Electronics document, Renesas Electronics products are not subject to radiation resistance design. You are responsible for implementing safety measures to guard against the possibility of bodily injury, injury or damage caused by fire, and/or danger to the public in the event of a failure or malfunction of Renesas Electronics products, such as safety design for hardware and software, including but not limited to redundancy, fire control and malfunction prevention, appropriate treatment for aging degradation or any other appropriate measures. Because the evaluation of microcomputer software alone is very difficult and impractical, you are responsible for evaluating the safety of the final products or systems manufactured by you.
10. Please contact a Renesas Electronics sales office for details as to environmental matters such as the environmental compatibility of each Renesas Electronics product. You are responsible for carefully and sufficiently investigating applicable laws and regulations that regulate the inclusion or use of controlled substances, including without limitation, the EU RoHS Directive, and using Renesas Electronics products in compliance with all these applicable laws and regulations. Renesas Electronics disclaims any and all liability for damages or losses occurring as a result of your noncompliance with applicable laws and regulations.
11. Renesas Electronics products and technologies shall not be used for or incorporated into any products or systems whose manufacture, use, or sale is prohibited under any applicable domestic or foreign laws or regulations. You shall comply with any applicable export control laws and regulations promulgated and administered by the governments of any countries asserting jurisdiction over the parties or transactions.
12. It is the responsibility of the buyer or distributor of Renesas Electronics products, or any other party who distributes, disposes of, or otherwise sells or transfers the product to a third party, to notify such third party in advance of the contents and conditions set forth in this document.
13. This document shall not be reprinted, reproduced or duplicated in any form, in whole or in part, without prior written consent of Renesas Electronics.
14. Please contact a Renesas Electronics sales office if you have any questions regarding the information contained in this document or Renesas Electronics products.

(Note1) "Renesas Electronics" as used in this document means Renesas Electronics Corporation and also includes its directly or indirectly controlled subsidiaries.

(Note2) "Renesas Electronics product(s)" means any product developed or manufactured by or for Renesas Electronics.

(Disclaimer Rev.5.0-1 October 2020)

Corporate Headquarters

TOYOSU FORESIA, 3-2-24 Toyosu,
Koto-ku, Tokyo 135-0061, Japan
www.renesas.com

Trademarks

Renesas and the Renesas logo are trademarks of Renesas Electronics Corporation. All trademarks and registered trademarks are the property of their respective owners.

Contact Information

For further information on a product, technology, the most up-to-date version of a document, or your nearest sales office, please visit:
www.renesas.com/contact/