

## Brief Description

The ZSPM2000 is a configurable true-digital single-phase PWM controller for high-current, non-isolated DC/DC supplies. The ZSPM2000 includes a high-speed MOSFET driver for a synchronous step-down converter in a single-rail and single-phase configuration.

The ZSPM2000 integrates a digital control loop, optimized for maximum flexibility and stability, as well as load step and steady-state performance. In addition, a rich set of protection and monitoring functions is provided. On-chip, non-volatile memory (NVM) and an I<sup>2</sup>C™ interface facilitate configuration.

IDT's PC-based Pink Power Designer™ graphical user interface (GUI) provides a user-friendly and easy-to-use interface to the device for communication and configuration. It can guide the user through the design of the digital compensator and offers intuitive configuration methods for additional features, such as protection and sequencing.

## Features

- Programmable digital control loop
- Advanced digital control techniques
  - Tru-sample Technology™
  - State-Law Control™ (SLC)
  - Sub-cycle Response™ (SCR)
- Improved transient response and noise immunity
- Protection features
  - Over-current protection
  - Over-voltage protection (VIN, VOUT)
  - Under-voltage protection (VIN, VOUT)
  - Overloaded startup
  - Restart and delay
- Integrated MOSFET driver with adaptive anti-cross-conduction protection
- Fuse-based NVM for improved reliability
- Operation from a single 5V or 3.3V supply
- Optional PMBus™ address selection without external resistors

## Benefits

- Fast configurability and design flexibility
- Simplified design and integration
- Reduced component count through system level integration
- Simplified monitoring for system power and thermal management
- Higher energy efficiency across all output loading conditions

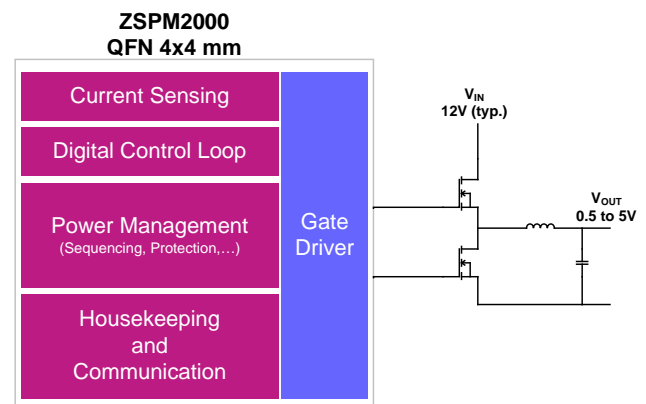
## Available Support

- Evaluation Kit
- PC-based Pink Power Designer™ GUI

## Physical Characteristics

- Operation temperature: -40°C to +85°C
- V<sub>OUT</sub> max: 5V
- VDD50 and VDD50DRV supply: 4.75V to 5.25V
- Lead free (RoHS-compliant)

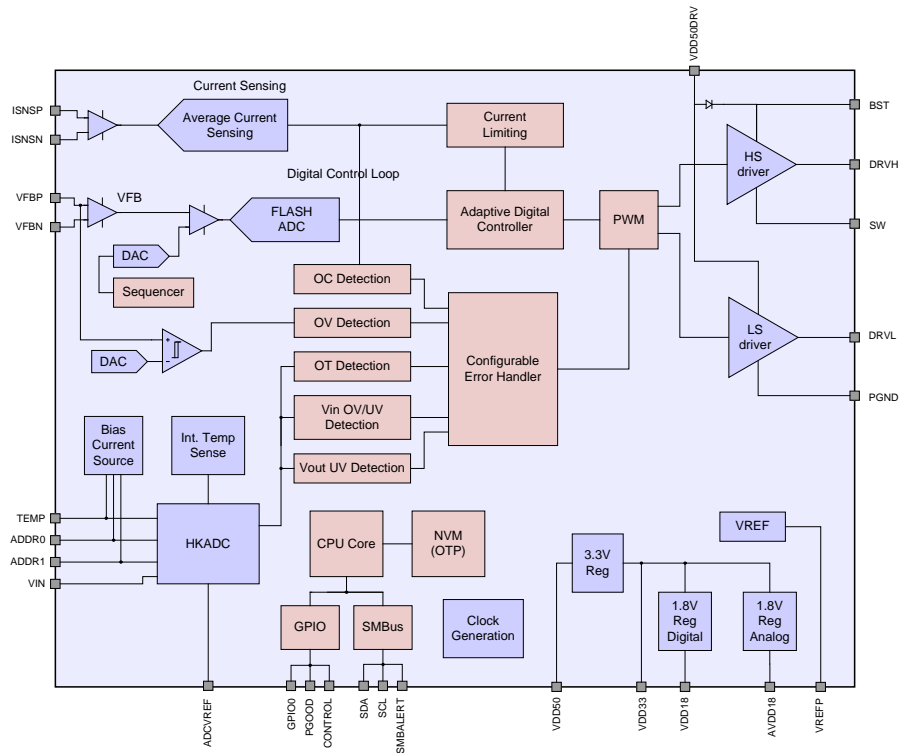
## ZSPM2000 Typical Application Diagram



<sup>\*</sup> I<sup>2</sup>C™ is a registered trademark of NXP.

ZSPM2000 Block Diagram

- Typical Applications**
- ❖ Telecom Switches
  - ❖ Servers and Storage
  - ❖ Base Stations
  - ❖ Network Routers
  - ❖ Industrial Applications
  - ❖ Single-Rail/Single-Phase Supplies for Processors, ASICs, FPGAs, DSPs



Ordering Information

Sales Code	Description	Package
ZSPM2000ZI2R 1	ZSPM2000 Lead-free QFN28 — Temperature range: -40°C to +85°C*	Reel
ZSPM2000-KIT01	Evaluation Kit for ZSPM2000 with PMBus™ Communication Interface — the Pink Power Designer™ GUI for kit can be downloaded from the IDT web site at <a href="http://www.IDT.com/ZSPM2000">www.IDT.com/ZSPM2000</a> (login required; see data sheet section 9 for details)	Kit

\* Note: This product is sold under a limited license from PowerOne, Inc. related to digital power technology as set forth in U.S. Patent 7000125 and other related patents owned by PowerOne, Inc. This license does not extend to stand-alone power supply products.

## Contents

1	IC Characteristics .....	6
1.1.	Absolute Maximum Ratings .....	6
1.2.	Recommended Operating Conditions .....	7
1.3.	Electrical Parameters .....	7
2	Product Summary.....	11
2.1.	Overview.....	11
2.2.	Pin Description.....	14
2.3.	Available Packages .....	15
3	Functional Description.....	16
3.1.	Power Supply Circuitry, Reference Decoupling, and Grounding .....	16
3.2.	Reset/Start-up Behavior .....	16
3.3.	Digital Power Control.....	16
3.3.1.	Overview .....	16
3.3.2.	Switching Frequency.....	16
3.3.3.	Output Voltage Feedback .....	17
3.3.4.	Digital Compensator.....	17
3.3.5.	Power Sequencing and the CONTROL Pin.....	18
3.3.6.	Pre-biased Start-up and Soft Stop .....	19
3.3.7.	Current Sensing .....	19
3.3.8.	Temperature Measurement .....	20
3.4.	Fault Monitoring and Response Generation.....	21
3.4.1.	Output Over/Under-Voltage .....	22
3.4.2.	Output Current Protection and Limiting.....	22
3.4.3.	Over-Temperature Protection .....	22
3.5.	GPIO0 Pin Configuration .....	23
3.6.	Configuration .....	23
4	PMBus™ Functionality .....	24
4.1.	Introduction .....	24
4.2.	Timing and Bus Specification .....	24
4.3.	Address Selection via External Resistors.....	25
4.4.	Configuration Registers .....	26
4.5.	Monitoring .....	28
4.6.	Miscellaneous .....	28
4.7.	Detailed Description of the Supported PMBus™ Commands.....	29
4.7.1.	OPERATION Command .....	29
4.7.2.	ON_OFF_CONFIG Command.....	29
4.7.3.	CLEAR_FAULTS Command.....	29
4.7.4.	VOUT_MODE Command.....	30

4.7.5.	VOUT_COMMAND Command .....	30
4.7.6.	STATUS_BYTE Command.....	30
4.7.7.	STATUS_WORD Command.....	31
4.7.8.	STATUS_VOUT Command .....	31
4.7.9.	STATUS_IOUT Command.....	32
4.7.10.	STATUS_INPUT Command .....	32
4.7.11.	STATUS_TEMPERATURE Command.....	32
4.7.12.	STATUS_CML Command.....	33
4.7.13.	STATUS_MFR_SPECIFIC Command.....	33
4.7.14.	READ_VIN Command.....	33
4.7.15.	READ_VOUT Command .....	33
4.7.16.	READ_IOUT Command.....	33
4.7.17.	READ_TEMPERATURE1 Command .....	34
4.7.18.	READ_TEMPERATURE2 Command .....	34
5	External Component Selection.....	35
5.1.	Output Voltage Feedback Components .....	35
5.2.	DCR Current Sensing Components .....	36
5.3.	Input Voltage Sensing .....	37
6	Synchronous MOSFET Driver Features .....	38
6.1.	Introduction .....	38
6.2.	Adaptive Non-overlap Dead-Time Control .....	38
6.3.	Layout Guidelines .....	38
7	Mechanical Specifications .....	39
8	Ordering Information .....	41
9	Related Documents.....	41
10	Glossary .....	41
11	Document Revision History .....	42

## List of Figures

Figure 2.1	Typical Application Circuit with a 5V Supply Voltage .....	12
Figure 2.2	Block Diagram.....	13
Figure 2.3	Pin-Out QFN28 Package .....	15
Figure 3.1	Simplified Block Diagram of the Digital Compensation .....	17
Figure 3.2	Power Sequencing.....	18
Figure 3.3	Power Sequencing with Non-zero Off Voltage .....	19
Figure 3.4	Inductor Current Sensing Using the DCR Method.....	20
Figure 4.1	PMBus™ Timing Diagram .....	24
Figure 5.1	Output Voltage Sense Circuitry .....	35
Figure 5.2	Inductor Current Sensing Using the DCR Method.....	36
Figure 5.3	Input Voltage Sense Circuitry .....	37
Figure 6.1	Adaptive Non-overlap Dead-Time Control Timing Diagram .....	38
Figure 7.1	28-Pin QFN Package Drawing.....	39
Figure 7.2	28-Pin QFN Recommended Mounting Footprint .....	40
Figure 7.3	Top Marking Diagram .....	40

## List of Tables

Table 3.1	Supported Switching Frequencies .....	16
Table 3.2	Fault Configuration Overview .....	21
Table 3.3	GPIO0 Pin Configuration Options.....	23
Table 4.1	PMBus™ Timing Specification .....	24
Table 4.2	Supported Resistor Values for PMBus™ Address Selection .....	25
Table 4.3	PMBus™ Address Selection without Resistors .....	26
Table 4.4	List of Supported PMBus™ Configuration Registers.....	26
Table 4.5	List of Supported PMBus™ Status Registers/Commands .....	28
Table 4.6	Additional Supported PMBus™ Registers.....	28
Table 4.7	Supported PMBus™ Operation Modes .....	29
Table 4.8	Supported PMBus™ ON_OFF_CONFIG Options.....	29
Table 5.1	Output Voltage Feedback Component Overview .....	35
Table 5.2	Input Voltage Sense Component Overview.....	37

# 1 IC Characteristics

## 1.1. Absolute Maximum Ratings

PARAMETER	SYMBOL	CONDITIONS	MIN	TYP	MAX	UNITS
<b>Supply voltages</b>						
5V supply voltage pins: VDD50 and VDD50DRV	$V_{DD50}$ $V_{DD50DRV}$	$dV/dt < 0.15V/\mu s$	-0.3		5.5	V
Maximum slew rate					0.15	V/ $\mu s$
3.3V supply voltage pin: VDD33	$V_{DD33}$		-0.3		3.6	V
1.8V supply voltage pins: VDD18 and AVDD18	$V_{DD18}$ $V_{AVDD18}$		-0.3		2.0	V
<b>Digital pins</b>						
Digital I/O pins: SCL, SCA, GPIO0, SMBALERT, CONTROL, and PGOOD			-0.3		5.5	V
<b>Analog pins</b>						
Current sensing pins: ISNSP and ISNSN			-0.3		5.5	V
Voltage feedback pins: VFBP and VFBN			-0.3		2.0	V
All other analog pins: ADCVREF, VIN, VREFP, TEMP, ADDR0, and ADDR1			-0.3		2.0	V
<b>MOSFET driver pins</b>						
Bootstrap supply voltage pin: BST	$V_{BST}$	Relative to SW	$V_{SW} - 0.3$		$V_{SW} + 6.5$	V
		Relative to PGND			35 40.0 at < 50ns	V
Switching node pin: SW (bootstrap supply return)	$V_{SW}$	Relative to PGND	-5.0 -10.0 at < 200ns		35 40.0 at < 50ns	V
High-side driver output pin: DRVH		Relative to BST			$V_{BST} + 0.3$	V
		Relative to SW	$V_{SW} - 0.3$ $V_{SW} - 2.0$ at <200ns			V
Low-side driver output pin: DRVL		Relative to PGND	-0.3 -5.0 at < 200ns		$V_{DD50DRV} + 0.3$	V
MOSFET driver power ground pin: PGND			0		0	V

PARAMETER	SYMBOL	CONDITIONS	MIN	TYP	MAX	UNITS
<b>Ambient conditions</b>						
Storage Temperature Range	T <sub>STOR</sub>		-40		150	°C
Electrostatic Discharge Protection	ESD	JEDEC JESD22-A114 (HBM)	1500			V
		JEDEC JESD22-A115 (MM)	100			V
Latch-Up Protection	LU	JEDEC JESD78	Class 1 Level A			
Moisture Sensitivity Level	MSL		1			

## 1.2. Recommended Operating Conditions

PARAMETER	SYMBOL	CONDITIONS	MIN	TYP	MAX	UNITS
<b>Ambient conditions</b>						
Operation temperature	T <sub>AMB</sub>		-40		85	°C

## 1.3. Electrical Parameters

PARAMETER	SYMBOL	CONDITIONS	MIN	TYP	MAX	UNITS
<b>Supply voltages</b>						
5V supply voltage – controller: VDD50 pin	V <sub>DD50</sub>		4.75	5.0	5.25	V
5V supply current - controller		VDD50=5.0V		23		mA
5V supply voltage – driver: VDD50DRV pin	V <sub>DD50DRV</sub>		4.75	5.0	5.25	V
3.3V supply voltage: VDD33 pin	V <sub>DD33</sub>		3.0	3.3	3.6	V
3.3V supply current		VDD50=VDD33=3.3V		23		mA
<b>Internally generated supply voltages</b>						
3.3V supply voltage: VDD33 pin		VDD50=5.0V	3.0	3.3	3.6	V
3.3V output current		VDD50=5.0V			2.0	mA
1.8V supply voltages: AVDD18 and VDD18 pin		VDD50=5.0V	1.72	1.80	1.98	V
1.8V output current					0	mA
Power on reset threshold – on: VDD33 pin				2.8		V
Power on reset threshold – off				2.6		V

PARAMETER	SYMBOL	CONDITIONS	MIN	TYP	MAX	UNITS
<b>Digital IO pins (GPIO0, CONTROL, PGOOD)</b>						
Input high voltage		VDD33=3.3V	2.0			V
Input low voltage		VDD33=3.3V			0.8	V
Output high voltage		VDD33=3.3V	2.4		VDD33	V
Output low voltage					0.5	V
Input leakage current					±1.0	µA
Output current – high					2.0	mA
Output current – low					2.0	mA
<b>SMBus pins (SCL, SDA, SMBALERT) – open drain</b>						
Input high voltage		VDD33=3.3V	2.0			V
Input low voltage		VDD33=3.3V			0.8	V
Maximum bus voltage					5.25	V
Output current – low					2.0	mA
<b>Output voltage (without external prescaler)</b>						
Set-point voltage			0		1.4	V
Set-point resolution				1.4		mV
Set-point accuracy		VOUT=1.4V		1		%
<b>Inductor current measurement</b>						
Common mode voltage: ISNSP and ISNSN pins relative to AGND			0		5.0	V
Differential voltage range: ISNSP to ISNSN pin					±100	mV
Accuracy				5		%
Recommended DCR sense voltage for maximum output current			10			mV
<b>Digital pulse width modulator</b>						
Switching frequency			177		1000	kHz
Resolution				163		ps
Frequency accuracy				2.0		%



PARAMETER	SYMBOL	CONDITIONS	MIN	TYP	MAX	UNITS
<b>Over-voltage protection</b>						
<b>Reference DAC</b>						
Set-point voltage			0		1.58	V
Resolution				25		mV
Set point accuracy				2		%
<b>Comparator</b>						
Hysteresis				35		mV
<b>HKADC input pins</b>						
Input voltage: TEMP, VIN, ADDR0, and ADDR1 pins			0		1.44	V
Source impedance Vin sensing					3	k $\Omega$
ADC resolution				0.7		mV
<b>External temperature measurement</b>						
Supported sense elements	PN-junction					
Bias current for external temperature sensing: TEMP pin				60		$\mu$ A
Resolution: TEMP pin				0.32		K
Accuracy of measurement: TEMP pin				$\pm$ 5.0		K
<b>Internal temperature measurement</b>						
Resolution				0.22		K
Accuracy of measurement				$\pm$ 5.0		K
<b>MOSFET driver pins</b>						
Output impedance, sourcing current—DRVH pin		$V_{BST}-V_{SW} = 5V$		0.9	1.7	$\Omega$
Output impedance, sinking current—DRVH pin		$V_{BST}-V_{SW} = 5V$		0.7	1.7	$\Omega$
Rise time—DRVH pin	$t_{rDRVH}$	$V_{DD50DRV} = 5V$ ; 3nF load $V_{BST}-V_{SW} = 5V$		16	25	ns
Fall time—DRVH pin	$t_{fDRVH}$	$V_{DD50DRV} = 5V$ ; 3nF load $V_{BST}-V_{SW} = 5V$		11	18	ns
Turn-on propagation delay—DRVH pin	$t_{pdhDRVH}$	$C_{LOAD} = 3nF$	10		30	ns
SW pin pull-down resistance		SW to PGND		45		k $\Omega$
DRVH pin pull-down resistance		DRVH to SW $V_{BST} - V_{SW} = 0V$		45		k $\Omega$

PARAMETER	SYMBOL	CONDITIONS	MIN	TYP	MAX	UNITS
Output impedance, sourcing current—DRV1 pin				0.9	1.7	$\Omega$
Output impedance, sinking current—DRV1 pin				0.4	0.8	$\Omega$
DRV1 rise time—DRV1 pin	$t_{rDRV1}$	$C_{LOAD} = 3nF$		16	25	ns
DRV1 fall time—DRV1 pin	$t_{fDRV1}$	$C_{LOAD} = 3nF$		11	15	ns
DRV1 turn-on propagation delay	$t_{pdDRV1}$	$C_{LOAD} = 3nF$	10		30	ns
DRV1 pin pull-down resistance	$R_{DRV1-PD}$	DRV1 to PGND $V_{DD50DRV} = PGND$		45		$k\Omega$
SW node leakage current				20		$\mu A$

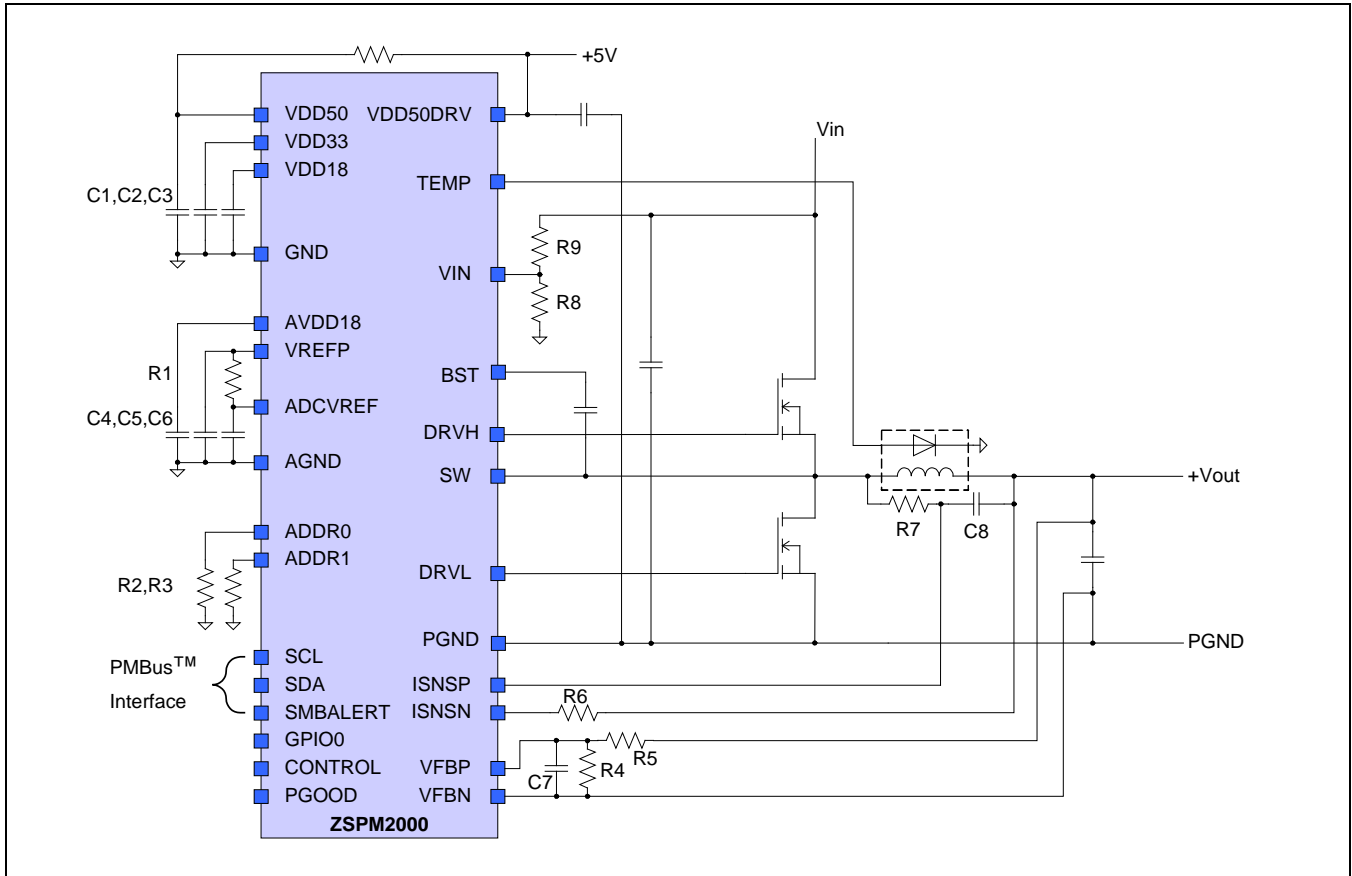
## 2 Product Summary

### 2.1. Overview

The ZSPM2000 is a configurable true-digital single-phase PWM controller for high-current, non-isolated DC/DC supplies supporting switching frequencies up to 1MHz. It offers a PMBus™ configurable digital power control loop incorporating output voltage sensing and average inductor current sensing, bundled with extensive fault monitoring and handling options. A high-speed MOSFET driver for a synchronous step-down converter is integrated in the ZSPM2000. The ZSPM2000 operates from a single 5V supply.

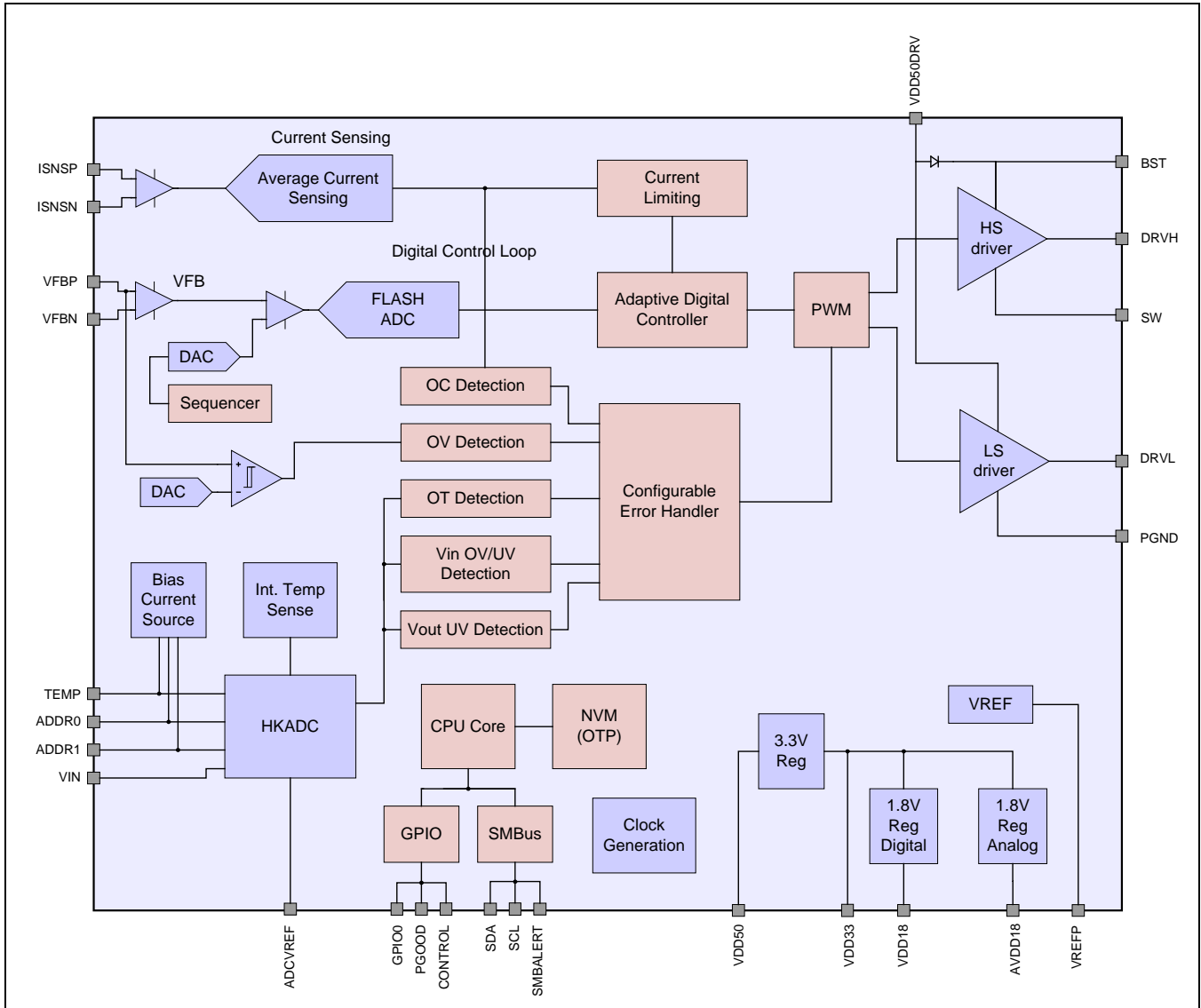
Several different functional units are incorporated in the ZSPM2000. A dedicated digital control loop is used to provide fast loop response and optimal output voltage regulation. This includes output voltage sensing, average inductor current sensing, a digital control law, and a digital pulse-width modulator (DPWM). In parallel, a dedicated, configurable error handler allows fast and flexible detection of error signals and their appropriate handling. A housekeeping analog-to-digital converter (HKADC) ensures the reliable and efficient measurement of environmental signals such as input voltage and temperature. An application-specific, low-power microcontroller is used to control the overall system. It manages configuration of the various logic units and handles the PMBus™ communication protocol. A PMBus™/SMBus/I<sup>2</sup>C™ interface is incorporated to connect with the outside world, supported by control and power-good (PGOOD) signals.

Figure 2.1 Typical Application Circuit with a 5V Supply Voltage



A high-reliability, high-temperature one-time programmable (OTP) memory is used to store configuration parameters. All required bias and reference voltages are internally derived from the external supply voltage.

Figure 2.2 Block Diagram



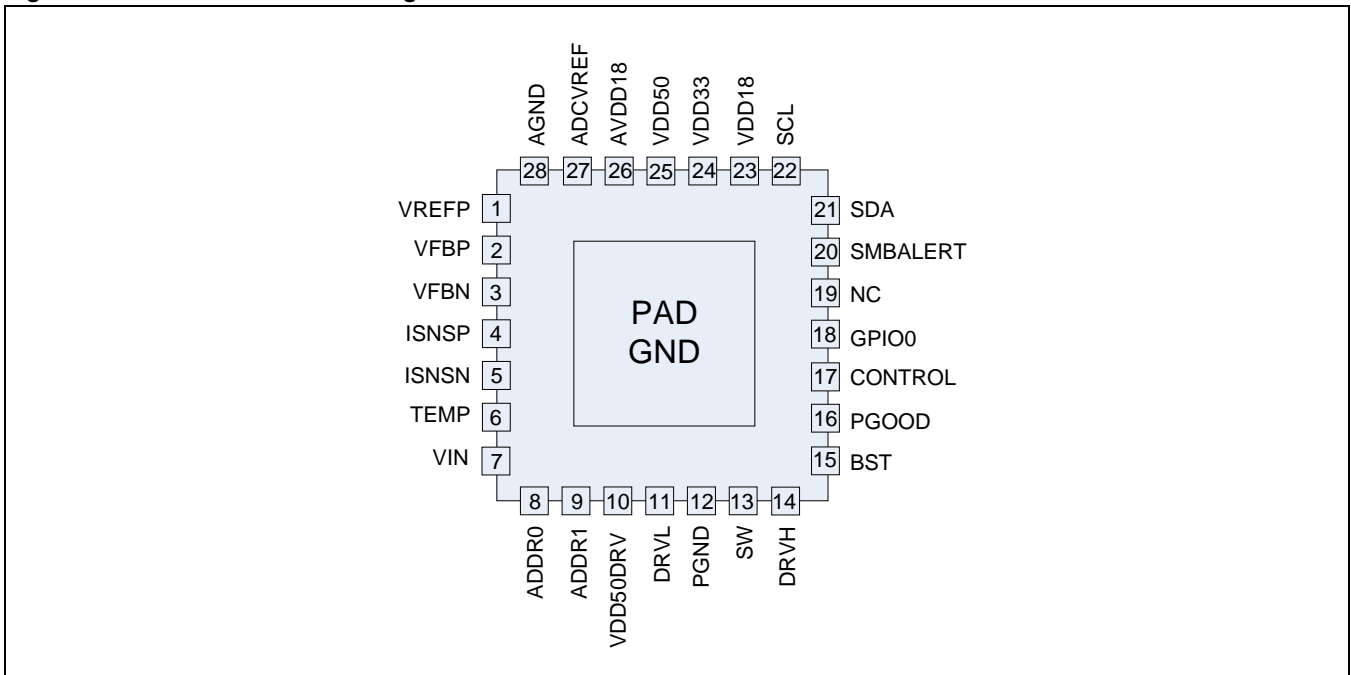
## 2.2. Pin Description

Pin	Name	Direction	Type	Description
1	VREFP	Output	Supply	Reference Terminal
2	VFBP	Input	Analog	Positive Input of Differential Feedback Voltage Sensing
3	VFBN	Input	Analog	Negative Input of Differential Feedback Voltage Sensing
4	ISNSP	Input	Analog	Positive Input of Differential Current Sensing
5	ISNSN	Input	Analog	Negative Input of Differential Current Sensing
6	TEMP	Input	Analog	Connection to External Temperature Sensing Element
7	VIN	Input	Analog	Power Supply Input Voltage Sensing
8	ADDR0	Input	Analog	SMBus Address Selection 0
9	ADDR1	Input	Analog	SMBus Address Selection 1
10	VDD50DRV	Input	Supply	5.0 V Supply Terminal for the integrated MOSFET Driver
11	DRVL	Output	Analog	Low-Side Driver Output
12	PGND	Input	Supply	Integrated MOSFET Driver Ground
13	SW	Input	Analog	Switching Node (Bootstrap Supply Return)
14	DRVH	Output	Analog	High-Side Driver Output
15	BST	Input	Analog	Bootstrap Supply Input
16	PGOOD	Output	Digital	PGOOD Output (Internal Pull-Down)
17	CONTROL	Input	Digital	Control Input
18	GPIO0	Input/Output	Digital	General Purpose Input/Output Pin
19	NC			Test pin – Do not connect
20	SMBALERT	Output	PMBus™	SMBus Alert Output
21	SDA	Input/Output	PMBus™	SMBus Shift Data I/O
22	SCL	Input	PMBus™	SMBus Shift Clock Input (slave-only)
23	VDD18	Output	Supply	Internal 1.8V Digital Supply Terminal
24	VDD33	Output	Supply	3.3V Supply Voltage Terminal
25	VDD50	Input	Supply	5.0V Supply Voltage Terminal
26	AVDD18	Output	Supply	Internal 1.8V Analog Supply Terminal
27	ADCVREF	Input	Analog	Analog-to-Digital Converter (ADC) Reference Terminal
28	AGND	Input	Supply	Analog Ground
PAD	GND	Input	Supply	Exposed PAD, Digital Ground

### 2.3. Available Packages

The ZSPM2000 is available in a 28-pin QFN package. The pin-out is shown in Figure 2.3. The mechanical drawing of the package can be found in Figure 7.1.

**Figure 2.3 Pin-Out QFN28 Package**



### 3 Functional Description

#### 3.1. Power Supply Circuitry, Reference Decoupling, and Grounding

The ZSPM2000 incorporates several internal power regulators in order to derive all required supply and bias voltages from a single external 5 V supply voltage on the VDD50DRV and VDD50 pins. The integrated MOSFET driver supply terminal VDD50DRV must be decoupled to the PGND pin (1.0 $\mu$ F minimum; 4.7 $\mu$ F recommended). Recommendation: Add a 10 $\Omega$  resistor between the VDD50DRV and VDD50 pins to provide sufficient decoupling between the pins.

Decoupling capacitors are required at the VDD50, VDD33, VDD18, and AVDD18 pins (1.0 $\mu$ F minimum; 4.7 $\mu$ F recommended). A small load current can be drawn from the VDD33 pin. For example, this can be used to supply pull-up resistors.

The reference voltages required for the analog-to-digital converters (ADCs) are generated within the ZSPM2000. External decoupling must be provided between the VREFP and ADCVREF pins. Therefore, a 4.7 $\mu$ F capacitor is required at the VREFP pin and a 100nF capacitor at ADCVREF pin. The two pins should be connected with approximately 50 $\Omega$  resistance in order to provide sufficient decoupling between the pins.

Three different ground connections are available on the outside of the package. Recommendation: Tie the AGND and the PAD together while separating the ground loop for the driver ground (PGND). Also use a single tie point close to the ZSPM2000 to tie the two ground connections together.

#### 3.2. Reset/Start-up Behavior

The ZSPM2000 employs an internal power-on-reset (POR) circuit to ensure proper start up and shut down with a changing supply voltage. Once the supply voltage increases above the POR threshold voltage, the ZSPM2000 begins the internal start-up process. Upon its completion, the device is ready for operation.

#### 3.3. Digital Power Control

##### 3.3.1. Overview

The digital power control loop consists of the integral parts required for the control functionality of the ZSPM2000. A high-speed analog front-end is used to digitize the output voltage. A digital control core uses the acquired information to provide duty-cycle information to the PWM, which controls the drive signals to the power stage.

##### 3.3.2. Switching Frequency

The ZSPM2000 supports the switching frequencies listed in Table 3.1.

**Table 3.1 Supported Switching Frequencies**

Supported Switching Frequencies			
1000kHz	571.4kHz	400.0kHz	266.6kHz
800kHz	500.0kHz	333.3kHz	222.0kHz
666.6kHz	444.4kHz	285.7kHz	177.0kHz



### 3.3.3. Output Voltage Feedback

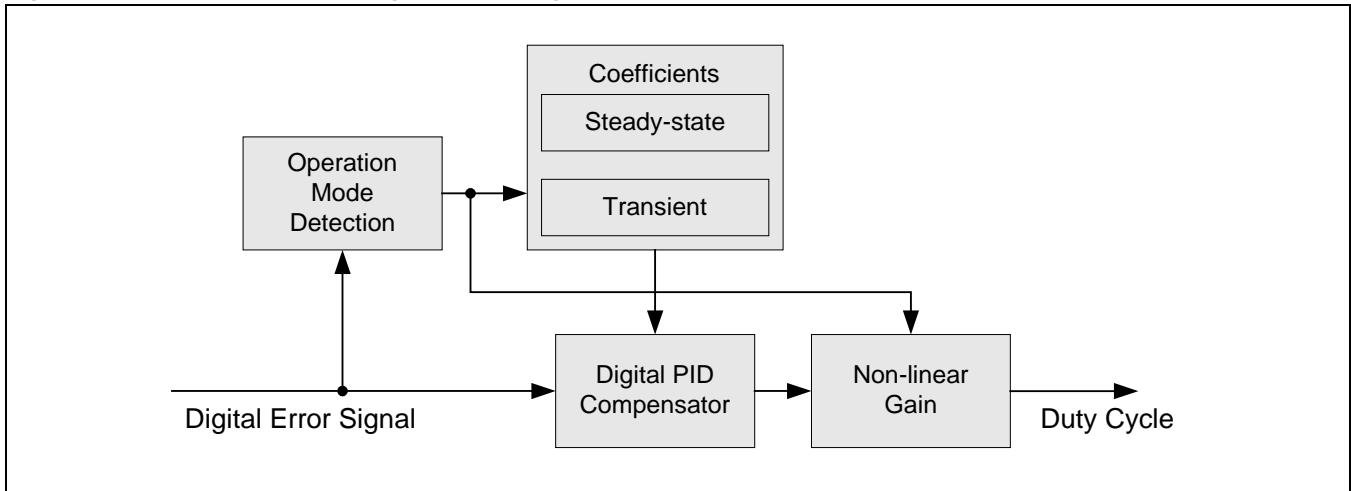
The voltage feedback signal is sampled with a high-speed analog front-end. The feedback voltage is differentially measured and subtracted from the voltage reference provided by a reference digital-to-analog converter (DAC) using an error amplifier. A flash ADC is then used to convert the voltage into its digital equivalent. This is followed by internal digital filtering to improve the system’s noise rejection.

Although the reference DAC generates a voltage up to 1.44V, keeping the voltage on the feedback pin (VFBP) at approximately 1.20V is recommended to guarantee sufficient headroom. If a larger output voltage is required, an external feedback divider is required.

### 3.3.4. Digital Compensator

The sampled output voltage is processed by a digital control loop in order to modulate the DPWM output signals controlling the power stage. This digital control loop works as a voltage-mode controller using a PID-type compensation. The basic structure of the controller is shown in Figure 3.1. The proprietary State-Law™ Control (SLC) concept features two parallel compensators for steady-state operation and fast transient operation. The coefficients for the two modes can be derived using the Pink Power Designer™ graphical user interface (GUI). The ZSPM2000 implements fast, reliable switching between the different compensation modes in order to ensure good transient performance and a quiet steady state. This allows tuning the compensators individually for the respective needs; i.e., quiet steady-state and fast transient performance.

**Figure 3.1 Simplified Block Diagram of the Digital Compensation**



Additionally, three different techniques are used to improve transient performance further. Tru-sample Technology™ is used to acquire fast, accurate, and continuous information about the output voltage so that the ZSPM2000 can react quickly to any change in output voltage. Tru-sample Technology™ reduces phase-lag caused by sampling delays, reduces noise sensitivity, and improves transient performance.

The Sub-cycle Response™ (SCR) technique, a method to drive the DPWM asynchronously during load transients, allows limiting the maximum deviation of the output voltage and allows recharging the output capacitors faster.

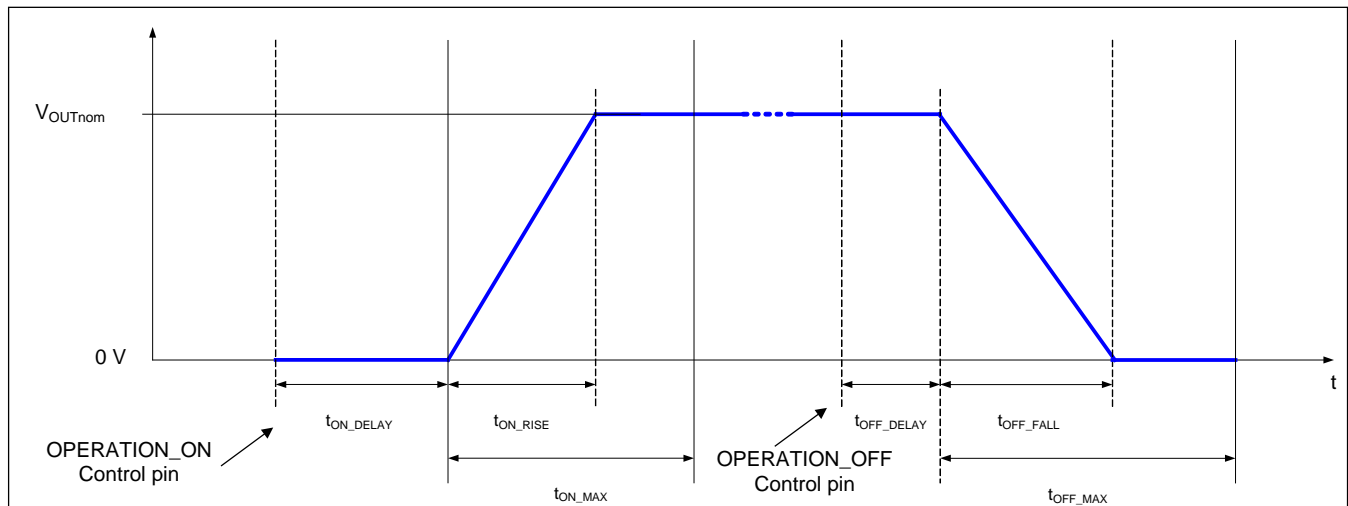
A non-linear gain adjustment is used during large load transients to boost the loop gain and reduce the settling time.

The DPWM supports switching frequencies up to 1MHz with a resolution of approximately 163ps. The minimum on-time and the maximum off-time of the modulation signal can be configured so that the ZSPM2000 can match the external power MOSFETs optimally. The functionality of the synchronous MOSFET driver is described in section 6.

### 3.3.5. Power Sequencing and the CONTROL Pin

The ZSPM2000 supports power sequencing features including ramp up/down and delays programmable via the Pink Power Designer™ GUI. The typical sequence of events is shown in Figure 3.2 and follows the PMBus™ standard. The individual values can be configured using the appropriate configuration setting. Three different configuration options are supported to turn on the output of the ZSPM2000. The device can be configured to turn on immediately after POR, on an OPERATION\_ON command, or on an edge on the CONTROL pin.

Figure 3.2 Power Sequencing

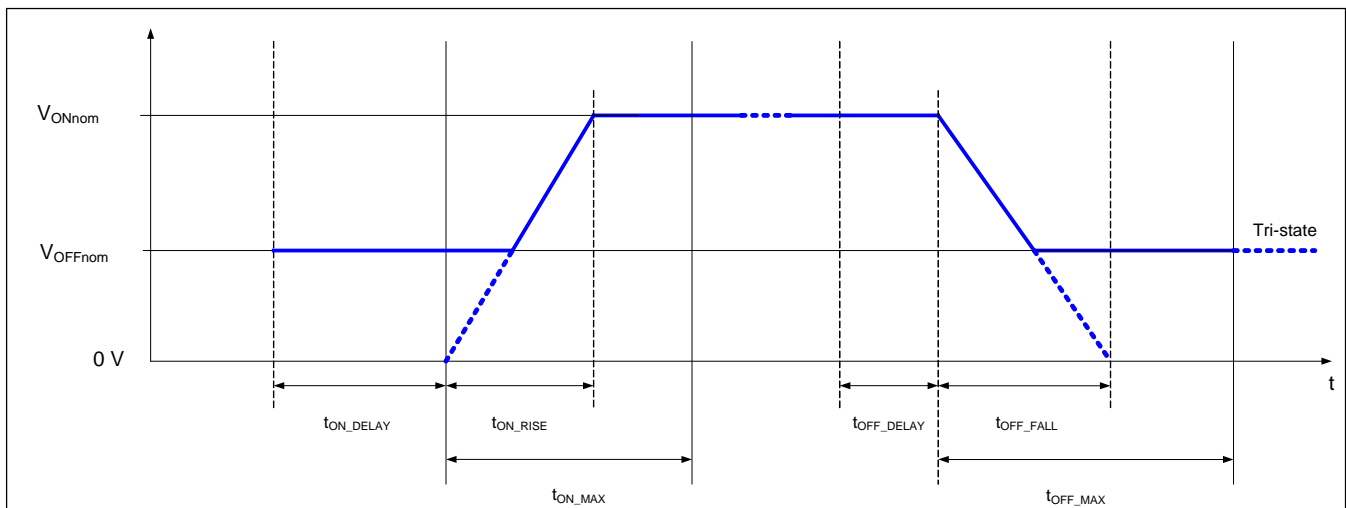


### 3.3.6. Pre-biased Start-up and Soft Stop

Dedicated pre-biased start-up logic ensures proper start-up of the power converter when the output capacitors are pre-charged to a non-zero output voltage. Closed-loop stability is ensured during this phase.

The ZSPM2000 also supports pre-biased off, i.e. the output voltage is not ramped down to zero and instead remains at a predefined level ( $V_{OFF\_nom}$ ). This value can be configured via the Pink Power Designer™ graphical user interface (GUI). After receiving the shutdown command, via PMBus™ or the CONTROL pin, the ZSPM2000 ramps down the value to the predefined value. Once the value is reached the MOSFET driver will be put into tri-state mode. Both gate drive outputs will be pulled low in the tri-state mode.

**Figure 3.3 Power Sequencing with Non-zero Off Voltage**

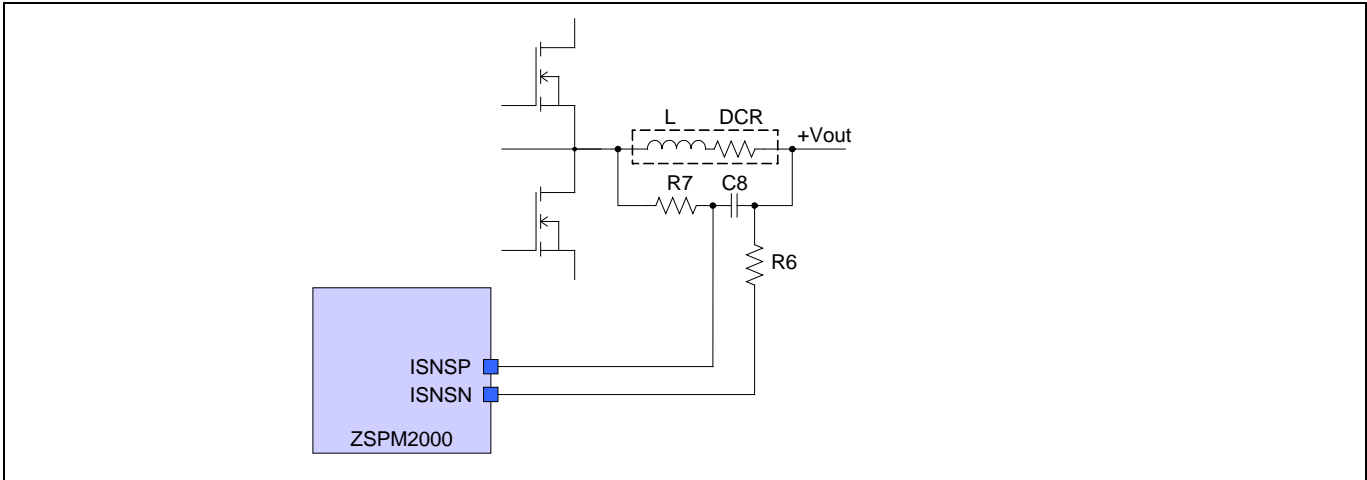


### 3.3.7. Current Sensing

The ZSPM2000 offers cycle-by-cycle average current sensing with configurable over-current protection. A dedicated ADC is used to provide fast and accurate current information over the switching period. The acquired information is compared with configurable current thresholds to report warning and error levels to the user. DCR current sensing across the inductor or across a dedicated shunt resistor is supported. Additionally, the device uses DCR temperature compensation via an external temperature sense element. This increases the accuracy of the current sense method by counteracting the significant change of the DCR over temperature.

To acquire accurate current information, the selection of the current sensing circuit is of critical importance. The schematic of the required current sensing circuitry is shown in Figure 3.4 for the widely-used DCR current-sensing method, which uses the parasitic resistance of the inductor to acquire the current information. The principle is based on a matched time-constant between the inductor and the low-pass filter comprising R7 and C8. The two resistors R6 and R7 should be matched fairly well in order to provide good DC voltage rejection; .i.e. to reduce the influence of the output voltage level in the current measurement.

Figure 3.4 Inductor Current Sensing Using the DCR Method



Alternatively, a simple shunt resistor can be used to measure the inductor current. The value of this resistor should be selected so that the voltage range between the pins is within the specifications given in section 1.

End-of-line calibration is supported so that the ZSPM2000 can achieve improved accuracy over the full output current range. The full calibration method is detailed in *ZSPM2000 Application Note—Programming and Calibration* (see section 9). This allows the user to correct mismatches between the nominal DCR value used to configure the device and the actual DCR value in the application caused by effects such as manufacturing variations. The calibration range is limited to +/- 50% of the nominal DCR.

Additionally, in order to improve the accuracy of the current measurement challenged by the temperature coefficient of the inductor's DCR, the ZSPM2000 features temperature compensation via external temperature sensing. The temperature of the inductors is measured with an external temperature sense element placed close to the inductor. This information is used to adapt the gain of the current sense path to compensate for the increase in actual DCR.

### 3.3.8. Temperature Measurement

The ZSPM2000 features two independent temperature measurement units for internal and external temperature. The internal temperature sensing measures the temperatures inside the ZSPM2000. The external temperature sense element should be placed close to the inductor to measure its temperature. A PN-junction is used as an external temperature sense element. Small-signal transistors, such as the 3904, are widely used for this application. The configuration of the sensitivity and the offset is required in the Pink Power Designer™ GUI. A temperature calibration via the Pink Power Designer™ or as part of the end-of-line calibration during production is highly recommended.

### 3.4. Fault Monitoring and Response Generation

The ZSPM2000 monitors various signals during operation. Depending on the selected configuration, it can respond to events generated by these signals. A wide range of options is configurable via the Pink Power Designer™ GUI. Typical monitoring within the ZSPM2000 is a three-step process. First, an event is detected via a configurable set of thresholds. This event is then digitally filtered before the ZSPM2000 reacts with a configurable response. For all monitored signals, a warning and a fault threshold can be configured. If enabled, a warning sets a status flag (see sections 4.7.6 through 4.7.11), but does not trigger a response; whereas a fault also generates a response.

Each warning and fault event can be individually enabled. The assertion of the SMBALERT signal can also be configured to individual needs. An overview of the options and configuration is given in Table 3.2.

**Table 3.2** Fault Configuration Overview

Signal	Response Type	Delay Resolution	Maximum Delay
Output Over-Voltage Fault	Low impedance*	500µs	90ms
Output Under-Voltage Fault	Low-impedance*	500µs	90ms
Input Over-Voltage Fault	High-impedance*	500µs	90ms
Input Under-Voltage Fault	High-impedance*	500µs	90ms
Over-Current Fault	Low-impedance*	500µs	90ms
External Over-Temperature Fault	Soft-Off*	5ms	900ms
Internal Over-Temperature Fault	Soft-Off*	5ms	900ms

\* The default options shown can be changed via the Pink Power Designer™ GUI.

The ZSPM2000 supports different response types individually configurable for each fault. The “low-impedance” response turns off the high-side external MOSFET and enables the low-side external MOSFET. After  $t_{OFF\_MAX}$  (see Figure 3.2), both MOSFETs will be turned off. Conversely, a “high-Z” response will disable both MOSFETs instantaneously. A “Soft-Off” response ramps the output voltage down similar to a power-down command. The voltage will be ramped down to the value selected for  $V_{OFF\_nom}$  (see Figure 3.3). After  $t_{OFF\_MAX}$ , the controller will disable the power stage by turning both switches off.

For each fault response, a delay and a retry setting can be configured via the Pink Power Designer™ GUI. If the delay value is set to non-zero, the ZSPM2000 will not respond to a fault immediately. Instead it will delay the response by the configured value and then reassess the signal. If the fault is still present, the appropriate response will be triggered. If the fault is no longer present, the previous detection will be disregarded. The retry setting configures the number of restarts of the power converter after a fault event. This number can be between zero and seven, where a setting of seven represents an infinite retry operation. In analog controllers, this feature is also known as “hiccup mode.”

### **3.4.1. Output Over/Under-Voltage**

To prevent damage to the load, the ZSPM2000 utilizes an output over-voltage protection circuit. The voltage at VFBP is continuously compared with a configurable threshold using a high-speed analog comparator. If the voltage exceeds the configured threshold, the fault response is generated and the PWM outputs are turned off. The voltage fault level is generated by a 6-bit DAC with a reference voltage of 1.60V resulting in 25mV resolution.

Additionally, the output voltage is sampled using the HKADC and continuously compared with an output over-voltage warning threshold. If the output voltage exceeds this threshold, a warning is generated and the preconfigured actions for the SMBALERT pin are triggered.

The ZSPM2000 also monitors the output voltage with two lower thresholds. If the output voltage is below the under-voltage warning level and above the under-voltage fault level, an output voltage under-voltage warning is triggered. If the output voltage falls below the fault level, a fault event is generated and the configured response is activated.

### **3.4.2. Output Current Protection and Limiting**

The ZSPM2000 continuously monitors the average inductor current and utilizes this information to protect the power supply from excessive output current. Two different types of protection are configurable independently.

Output current limiting to a value configurable via the Pink Power Designer™ GUI is supported by reducing the output voltage. Additionally, the maximum output current warning and fault threshold can be used to shut down the ZSPM2000. Both features can be enabled independently. If the over-current fault threshold is chosen below the current limiting threshold, the ZSPM2000 will shut down without going into current limiting mode.

### **3.4.3. Over-Temperature Protection**

The ZSPM2000 monitors internal and external temperature. For each, a warning and a fault level can be configured and an appropriate response can be enabled.

### 3.5. GPIO0 Pin Configuration

The ZSPM2000 offers a flexible configuration scheme for its digital I/O pin. This enables using the GPIO0 pin (general purpose input/output) with different functions depending on the application requirements. The configuration options are listed in Table 3.3.

**Table 3.3** *GPIO0 Pin Configuration Options*

Pin	Thermal shutdown	Hardwire Option
GPIO0	High and low active	High and low active

The GPIO pin can be hardwired to be high or low, or it can be used as a thermal shutdown input. If the pin is asserted by an external source, for example the thermal shutdown flag of an external temperature sensor, the ZSPM2000 flags an external over-temperature fault and reacts accordingly.

### 3.6. Configuration

The ZSPM2000 incorporates two different sets of configuration parameters. The first set of configuration parameters can be configured during design time and cannot be changed during run-time. The second set of configuration parameters can be configured during design time, but can also be reconfigured during run-time using the appropriate PMBus™ command. Note that these reconfigured values are not stored in the OTP memory, so they are lost during power cycling the device.

In order to evaluate the device and its configuration on the bench, a special engineering mode is supported by the device and Pink Power Designer™ GUI; i.e. the device can be reconfigured multiple times without writing the configuration into the OTP. During this engineering mode, the device starts up after power-on reset in an unconfigured state. The Pink Power Designer™ then provides the configuration to the ZSPM2000, enabling full operation without actually configuring the OTP. The engineer can use this mode to evaluate the configuration on the bench. However, the configuration will be lost upon power-on-reset.

After the design engineer has determined the final configuration options, an OTP image can be created that is then written into the ZSPM2000. This can be either on the bench using the Pink Power Designer™ or in end-of-line testing during mass production.

## 4 PMBus™ Functionality

### 4.1. Introduction

The ZSPM2000 supports the PMBus™ protocol to enable the use of configuration, monitoring, and fault management during run-time.

The PMBus™ host controller is connected to the ZSPM2000 via the PMBus™ pins: SDA and SCL. A dedicated SMBALERT pin is provided to notify the host that new status information is present.

The ZSPM2000 supports packet error correction (PEC) according to the PMBus™ specification.

### 4.2. Timing and Bus Specification

Figure 4.1 PMBus™ Timing Diagram

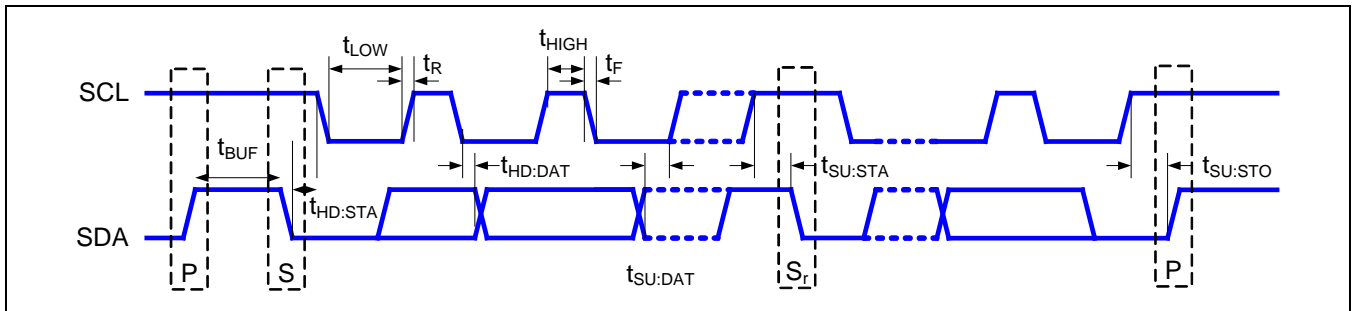


Table 4.1 PMBus™ Timing Specification

PARAMETER	SYMBOL	CONDITIONS	MIN	TYP	MAX	UNITS
SMBus operation frequency	$f_{SMB}$		10	400	500	kHz
Bus free time between start and stop	$t_{BUF}$		1.3			$\mu$ s
Hold time after start condition	$t_{HD:STA}$		0.6			$\mu$ s
Repeat start condition setup time	$t_{SU:STA}$		0.6			$\mu$ s
Stop condition setup time	$t_{SU:STO}$		0.6			$\mu$ s
Data hold time	$t_{HD:DAT}$		300			ns
Data setup time	$t_{SU:DAT}$		100			ns
Clock low time-out	$t_{TIMEOUT}$			25	35	ms
Clock low period	$t_{LOW}$		1.3			$\mu$ s
Clock high period	$t_{HIGH}$		0.6			$\mu$ s
Cumulative clock low extend time	$t_{LOW:SEXT}$				25	ms
Clock or data fall time	$t_F$				300	ns
Clock or data rise time	$t_R$				300	ns



### 4.3. Address Selection via External Resistors

PMBus™ uses a 7-bit device address to identify different devices connected to the bus. This address can be selected via external resistors connected to the ADDR<sub>x</sub> pins.

The resistor values are sensed using the internal ADC during the initialization phase, and the appropriate PMBus™ address is selected. Note that the respective circuitry is only active during the initialization phase; hence no DC voltage can be measured at the pins. The supported PMBus™ addresses and the values of the respective required resistors are listed in Table 4.2.

**Table 4.2 Supported Resistor Values for PMBus™ Address Selection**

Address (Decimal)	ADDR1 Ω	ADDR0 Ω	Address (Decimal)	ADDR1 Ω	ADDR0 Ω	Address (Decimal)	ADDR1 Ω	ADDR0 Ω	Address (Decimal)	ADDR1 Ω	ADDR0 Ω
64	0	0	32	1.2k	0	64	2.7k	0	96	4.7k	0
1*	0	680	33	1.2k	680	65	2.7k	680	97*	4.7k	680
2*	0	1.2k	34	1.2k	1.2k	66	2.7k	1.2k	98	4.7k	1.2k
3*	0	1.8k	35	1.2k	1.8k	67	2.7k	1.8k	99	4.7k	1.8k
4*	0	2.7k	36	1.2k	2.7k	68	2.7k	2.7k	100	4.7k	2.7k
5*	0	3.9k	37	1.2k	3.9k	69	2.7k	3.9k	101	4.7k	3.9k
6*	0	4.7k	38	1.2k	4.7k	70	2.7k	4.7k	102	4.7k	4.7k
7*	0	5.6k	39	1.2k	5.6k	71	2.7k	5.6k	103	4.7k	5.6k
8*	0	6.8k	40*	1.2k	6.8k	72	2.7k	6.8k	104	4.7k	6.8k
9	0	8.2k	41	1.2k	8.2k	73	2.7k	8.2k	105	4.7k	8.2k
10	0	10k	42	1.2k	10k	74	2.7k	10k	106	4.7k	10k
11	0	12k	43	1.2k	12k	75	2.7k	12k	107	4.7k	12k
12*	0	15k	44	1.2k	15k	76	2.7k	15k	108	4.7k	15k
13	0	18k	45	1.2k	18k	77	2.7k	18k	109	4.7k	18k
14	0	22k	46	1.2k	22k	78	2.7k	22k	110	4.7k	22k
15	0	27k	47	1.2k	27k	79	2.7k	27k	111	4.7k	27k
16	680	0	48	1.8k	0	80	3.9k	0	112	5.6k	0
17	680	680	49	1.8k	680	81	3.9k	680	113	5.6k	680
18	680	1.2k	50	1.8k	1.2k	82	3.9k	1.2k	114	5.6k	1.2k
19	680	1.8k	51	1.8k	1.8k	83	3.9k	1.8k	115	5.6k	1.8k
20	680	2.7k	52	1.8k	2.7k	84	3.9k	2.7k	116	5.6k	2.7k
21	680	3.9k	53	1.8k	3.9k	85	3.9k	3.9k	117	5.6k	3.9k
22	680	4.7k	54	1.8k	4.7k	86	3.9k	4.7k	118	5.6k	4.7k
23	680	5.6k	55*	1.8k	5.6k	87	3.9k	5.6k	119	5.6k	5.6k
24	680	6.8k	56	1.8k	6.8k	88	3.9k	6.8k	120*	5.6k	6.8k
25	680	8.2k	57	1.8k	8.2k	89	3.9k	8.2k	121*	5.6k	8.2k
26	680	10k	58	1.8k	10k	90	3.9k	10k	122*	5.6k	10k
27	680	12k	59	1.8k	12k	91	3.9k	12k	123*	5.6k	12k
28	680	15k	60	1.8k	15k	92	3.9k	15k	124*	5.6k	15k
29	680	18k	61	1.8k	18k	93	3.9k	18k	125*	5.6k	18k
30	680	22k	62	1.8k	22k	94	3.9k	22k	126*	5.6k	22k
31	680	27k	63	1.8k	27k	95	3.9k	27k	127*	5.6k	27k

\*Note: The addresses marked with an asterisk (\*) are reserved by the SMBus specification.

If only four devices are used in a system, their respective addresses can alternatively be configured without resistors by connecting the pins to GND or AVDD18 pin. The PMBus™ addresses selectable in this fashion are listed in Table 4.3.

**Table 4.3** PMBus™ Address Selection without Resistors

Address	ADDR1	ADDR0
15	GND	AVDD18
48	AVDD18	GND
63	AVDD18	AVDD18
64	GND	GND

#### 4.4. Configuration Registers

The registers described in Table 4.4 are used to configure the ZSPM2000 as explained in section 3.6. Registers classified as OTP cannot be changed during run-time. Registers classified as PMBus™ can be changed during run-time with PMBus™ commands.

**Table 4.4** List of Supported PMBus™ Configuration Registers

Note: See important notes at the end of the table.

PMBus™ Parameter	Description	Data Format	Classification
<b>Output Voltage</b>			
ON_OFF_CONFIG	On/off configuration	N/A	PMBus™
VOUT_MODE	Exponent of the VOUT_COMMAND value	N/A	Read only
VOUT_COMMAND	Set output voltage	LINEAR <sup>(1)</sup>	PMBus™
VOUT_OV_FAULT_LIMIT	Over-voltage fault limit	N/A	OTP
VOUT_OV_FAULT_RESPONSE	Over-voltage fault response	N/A	OTP
VOUT_OV_WARN_LIMIT	Over-voltage warning level	N/A	OTP
VOUT_UV_WARN_LIMIT	Under-voltage warning level	N/A	OTP
VOUT_UV_FAULT_LIMIT	Under-voltage fault level	N/A	OTP
VOUT_UV_FAULT_RESPONSE	Under-voltage fault response	N/A	OTP
<b>Output Current</b>			
IOUT_OC_FAULT_LIMIT	Over-current fault limit	N/A	OTP
IOUT_OC_FAULT_RESPONSE	Over-current fault response	N/A	OTP
IOUT_OC_LV_FAULT_LIMIT	Voltage threshold during constant-current mode	N/A	OTP
IOUT_OC_WARN_LIMIT	Over-current warning level	N/A	OTP

PMBus™ Parameter	Description	Data Format	Classification
<b>Temperature - External</b>			
OT_FAULT_LIMIT	Over-temperature fault level	N/A	OTP
OT_FAULT_RESPONSE	Over-temperature fault response	N/A	OTP
OT_WARN_LIMIT	Over-temperature warning level	N/A	OTP
<b>Temperature - Internal</b>			
IOT_FAULT_LIMIT	Over-temperature fault level	N/A	OTP
IOT_FAULT_RESPONSE	Over-temperature fault response	N/A	OTP
IOT_WARN_LIMIT	Over-temperature warning level	N/A	OTP
<b>Input Voltage</b>			
VIN_OV_FAULT_LIMIT	Over-voltage fault limit	N/A	OTP
VIN_OV_FAULT_RESPONSE	Over-voltage fault response	N/A	OTP
VIN_OV_WARN_LIMIT	Over-voltage warning level	N/A	OTP
VIN_UV_WARN_LIMIT	Under-voltage warning level	N/A	OTP
VIN_UV_FAULT_LIMIT	Under-voltage fault level	N/A	OTP
VIN_UV_FAULT_RESPONSE	Under-voltage fault response	N/A	OTP
<b>Start-up Behavior / Power Sequencing</b>			
POWER_GOOD_ON	Power good on threshold	N/A	OTP
POWER_GOOD_OFF	Power good off threshold	N/A	OTP
<b>Output Voltage Sequencing</b>			
TON_DELAY	Turn-on delay	N/A	OTP
TON_RISE	Turn-on rise time	N/A	OTP
TON_FAULT_MAX	Turn-on maximum fault time	N/A	OTP
TOFF_DELAY	Turn-off delay	N/A	OTP
TOFF_FALL	Turn-off fall time	N/A	OTP
TOFF_WARN_MAX	Turn-off maximum warning time	N/A	OTP
VOFF_NOM	Soft-stop off value	N/A	OTP
Notes:			
1. VOUT_MODE is read-only for this device.			

The ZSPM2000 supports the LINEAR data format according to the PMBus™ specification. Note that in accordance with the PMBus™ specification, all commands related to the output voltage are subject to the VOUT\_MODE settings. Note that VOUT\_MODE is read-only for the ZSPM2000.

## 4.5. Monitoring

The ZSPM2000 has a dedicated set of PMBus™ registers to enable advanced power management using extensive monitoring features. Different warning and error flags can be read by the PMBus™ master to ensure proper operation of the power converter or monitor the converters over its lifetime.

**Table 4.5 List of Supported PMBus™ Status Registers/Commands**

PMBus™ Command	Code	Description	Data Format
CLEAR_FAULTS	03 <sub>HEX</sub>	Clear status information	
STATUS_BYTE	78 <sub>HEX</sub>	Unit status byte	
STATUS_WORD	79 <sub>HEX</sub>	Unit status word	
STATUS_VOUT	7A <sub>HEX</sub>	Output voltage status	
STATUS_IOUT	7B <sub>HEX</sub>	Output current status	
STATUS_INPUT	7C <sub>HEX</sub>	Input status	
STATUS_TEMPERATURE	7D <sub>HEX</sub>	Temperature status	
STATUS_CML	7E <sub>HEX</sub>	Communication and memory status	
STATUS_MFR_SPECIFIC	7F <sub>HEX</sub>	Manufacturer-specific status	
READ_VIN	88 <sub>HEX</sub>	Input voltage read back	LINEAR
READ_VOUT	8B <sub>HEX</sub>	Output voltage read back	LINEAR
READ_IOUT	8C <sub>HEX</sub>	Output current read back	LINEAR
READ_TEMPERATURE_1	8D <sub>HEX</sub>	External temperature read back	LINEAR
READ_TEMPERATURE_2	8E <sub>HEX</sub>	Internal temperature read back	LINEAR

## 4.6. Miscellaneous

**Table 4.6 Additional Supported PMBus™ Registers**

PMBus™ Command	Code	Description	Data Length (Byte)	Values
PMBUS_REVISION	98 <sub>HEX</sub>	PMBus™ revision	1	11 <sub>HEX</sub>
MFR_ID	99 <sub>HEX</sub>	Manufacturer ID	4	"ZMDI" (5A <sub>HEX</sub> , 4D <sub>HEX</sub> , 44 <sub>HEX</sub> , 49 <sub>HEX</sub> )
MFR_MODEL	9A <sub>HEX</sub>	Manufacturer model identifier	4	"2000" (32 <sub>HEX</sub> , 30 <sub>HEX</sub> , 30 <sub>HEX</sub> , 30 <sub>HEX</sub> )
MFR_REVISION	9B <sub>HEX</sub>	Manufacturer product revision	4	
MFR_SERIAL	9E <sub>HEX</sub>	Serial number	12	

## 4.7. Detailed Description of the Supported PMBus™ Commands

### 4.7.1. OPERATION Command

The OPERATION command is used to turn the unit on and off in conjunction with the input from the CONTROL pin. The unit stays in the commanded operating mode until a subsequent OPERATION command or change in the state of the CONTROL pin instructs the ZSPM2000 to change to another mode. The supported operation modes are listed in Table 4.7.

**Table 4.7 Supported PMBus™ Operation Modes**

OPERATION (01 <sub>HEX</sub> , read/write)					
Bits[7:6]	Bits[5:4]	Bits[3:2]	Bits[1:0]	Unit On or Off	Margin State
01	XX	XX	XX	Soft Off (With Sequencing)	N/A
10	00	XX	XX	On	Off

### 4.7.2. ON\_OFF\_CONFIG Command

The ON\_OFF\_CONFIG command is used to configure the combination of the CONTROL pin and PMBus™ OPERATION command that turns the unit on or off. The supported configuration options are listed in Table 4.8.

**Table 4.8 Supported PMBus™ ON\_OFF\_CONFIG Options**

ON_OFF_CONFIG (02 <sub>HEX</sub> , read/write)		
Bits	Name	Description
[0]	CONTROL OFF	Value ignored. Device always uses the programmed turn off delay and fall time.
[1]	CONTROL Polarity	0: Active low (pull pin low to start the unit). 1: Active high (pull pin high to start the unit).
[2]	CONTROL Enable	0: Unit ignores the CONTROL pin. 1: Unit requires the CONTROL pin to be asserted to start the unit.*
[3]	OPERATION Enable	0: Unit ignores the on/off settings in the OPERATION command. 1: Unit requires the on/off settings in the OPERATION command to start the unit*.

\* Depending on the configuration, both conditions must be in the on state in order to turn on the unit.

### 4.7.3. CLEAR\_FAULTS Command

The CLEAR\_FAULTS command is used to clear any fault bits that have been set in the status registers. Additionally, the SMBALERT signal is cleared if it was previously asserted. Note that the device resumes operation with the currently configured state after a CLEAR\_FAULTS command has been issued. If a fault/warning is still present, the respective bit is set immediately again.

#### 4.7.4. VOUT\_MODE Command

The VOUT\_MODE command is used to retrieve information about the data format for all output voltage related commands. Note that this is a read-only value.

VOUT_MODE (20 <sub>HEX</sub> , read only)		
Bits	Name	Description
[4:0]	PARAMETER	2's complement of the exponent
[7:5]	MODE	000: Linear data format

#### 4.7.5. VOUT\_COMMAND Command

The VOUT\_COMMAND is used to set the output voltage during run-time.

VOUT_COMMAND (21 <sub>HEX</sub> , read/write)		
Bits	Name	Description
[15:0]	MANTISSA	Unsigned mantissa of output voltage in V. Exponent can be retrieved via VOUT_MODE command.

#### 4.7.6. STATUS\_BYTE Command

The STATUS\_BYTE command returns a summary of the most critical faults in one byte.

STATUS_BYTE (78 <sub>HEX</sub> , read only)		
Bits	Name	Description
[0]	NONE OF THE ABOVE	A fault not listed in bits [7:1] has occurred.
[1]	CML	A communication fault as occurred.
[2]	TEMPERATURE	A temperature fault or warning has occurred.
[3]	VIN_UV	An input under-voltage fault has occurred.
[4]	IOUT_OC	An output over-current fault has occurred.
[5]	VOUT_OV	An output over-voltage fault has occurred.
[6]	OFF	This bit is asserted if the unit is not providing power to the output, regardless of the reason, including simply not being enabled.
[7]	BUSY	Not supported.

#### 4.7.7. STATUS\_WORD Command

The STATUS\_WORD command returns a summary of the device status information in two data bytes.

STATUS_WORD (79 <sub>HEX</sub> , read only)		
Bits	Name	Description
[7:0]	STATUS_BYTE	See status byte (section 4.7.6).
[8]	UNKNOWN	Not supported
[9]	OTHER	Not supported
[10]	FANS	No supported
[11]	POWER_GOOD#	The POWER_GOOD signal, if present, is negated.
[12]	MFR	A manufacturer-specific fault or warning has occurred.
[13]	INPUT	An input related warning or fault has occurred.
[14]	IOUT/POUT	An output current or output power warning or fault has occurred.
[15]	VOUT	An output voltage related warning or fault has occurred.

#### 4.7.8. STATUS\_VOUT Command

STATUS_VOUT (7A <sub>HEX</sub> , read only)		
Bits	Name	Description
[0]		Not supported.
[1]		Not supported.
[2]		Not supported.
[3]		Not supported.
[4]	VOUT_UV_FLT	An output voltage under-voltage fault has occurred.
[5]	VOUT_UV_WARN	An output voltage under-voltage warning has occurred.
[6]	VOUT_OV_WARN	An output voltage over-voltage warning has occurred.
[7]	VOUT_OV_FLT	An output voltage over-voltage fault has occurred.

#### 4.7.9. STATUS\_IOUT Command

STATUS_IOUT (7B <sub>HEX</sub> , read only)		
Bits	Name	Description
[0]		Not supported.
[1]		Not supported.
[2]		Not supported.
[3]		Not supported.
[4]		Not supported.
[5]	IOUT_OC_WARN	An over-current warning has occurred.
[6]	ICOUT_OC_LV_FLT	An over-current low-voltage shutdown fault has occurred.
[7]	IOUT_OC_FLT	An over-current fault has occurred.

#### 4.7.10. STATUS\_INPUT Command

STATUS_INPUT (7C <sub>HEX</sub> , read only)		
Bits	Name	Description
[0]		Not supported.
[1]		Not supported.
[2]		Not supported.
[3]		Not supported.
[4]	VIN_UV_FLT	An input voltage under-voltage fault has occurred.
[5]	VIN_UV_WARN	An input voltage under-voltage warning has occurred.
[6]	VIN_OV_WARN	An input voltage over-voltage warning has occurred.
[7]	VIN_OV_FLT	An input voltage over-voltage fault has occurred.

#### 4.7.11. STATUS\_TEMPERATURE Command

STATUS_TEMPERATURE (7D <sub>HEX</sub> , read only)		
Bits	Name	Description
[0]		Not supported.
[1]		Not supported.
[2]		Not supported.
[3]		Not supported.
[4]		Not supported.
[5]		Not supported.
[6]	TEMP_OV_WARN	An (external) over-temperature warning has occurred.
[7]	TEMP_OV_FLT	An (external) over-temperature fault has occurred.



#### 4.7.12. STATUS\_CML Command

STATUS_CML (7E <sub>HEX</sub> , read only)		
Bits	Name	Description
[0]		Not supported.
[1]	SMBUS_FLT	SMBus™ timeout or a format error has occurred.
[2]		Not supported.
[3]		Not supported.
[4]		Not supported.
[5]	PEC_FLT	A packet error check fault has occurred.
[6]		Not supported.
[7]	CMD_FLT	An invalid or an unsupported command has been received.

#### 4.7.13. STATUS\_MFR\_SPECIFIC Command

STATUS_MFR_SPECIFIC (80 <sub>HEX</sub> , read only)		
Bits	Name	Description
[0]		Not supported.
[1]		Not supported.
[2]		Not supported.
[3]		Not supported.
[4]		Not supported.
[5]		Not supported.
[6]	ITEMP_OV_WARN	An (internal) over-temperature warning has occurred.
[7]	ITEMP_OV_FLT	An (internal) over-temperature fault has occurred.

#### 4.7.14. READ\_VIN Command

READ_VIN (88 <sub>HEX</sub> , read only)		
Bits	Name	Description
[15:0]	VIN	Input voltage in V (linear data format).

#### 4.7.15. READ\_VOUT Command

READ_VOUT (8B <sub>HEX</sub> , read only)		
Bits	Name	Description
[15:0]	VOUT	Output voltage in V (linear data format). Note that this command is mantissa only.

#### 4.7.16. READ\_IOUT Command

READ_IOUT (8C <sub>HEX</sub> , read only)		
---	--	--

Bits	Name	Description
[15:0]	IOUT	Output current in amperes (linear data format).

#### 4.7.17. READ\_TEMPERATURE1 Command

READ_TEMPERATURE1 (8D <sub>HEX</sub> , read only)		
Bits	Name	Description
[15:0]	TEMP1	External temperature in °C (linear data format).

#### 4.7.18. READ\_TEMPERATURE2 Command

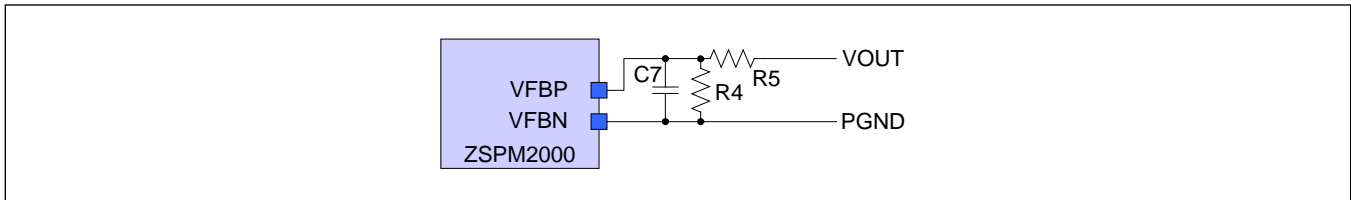
READ_TEMPERATURE2 (8E <sub>HEX</sub> , read only)		
Bits	Name	Description
[15:0]	TEMP2	Internal temperature in °C (linear data format).

## 5 External Component Selection

### 5.1 Output Voltage Feedback Components

The ZSPM2000 supports direct output voltage feedback without external components up to an output voltage of 1.4V. However, adding a high-frequency low-pass filter in the sense path is highly recommended to remove high-frequency disturbances from the sense signals. Placing these components as close as possible to the ZSPM2000 is recommended. For larger output voltages, a feedback divider is required. Using resistors with small tolerances is recommended to guarantee good output voltage accuracy. Table 5.1 lists the required component values as a function of the maximum supportable output voltage. It is mandatory that the selected resistors values are configured in the Pink Power Designer™ GUI so that they can be taken into account for the configuration of the ZSPM2000.

**Figure 5.1** Output Voltage Sense Circuitry

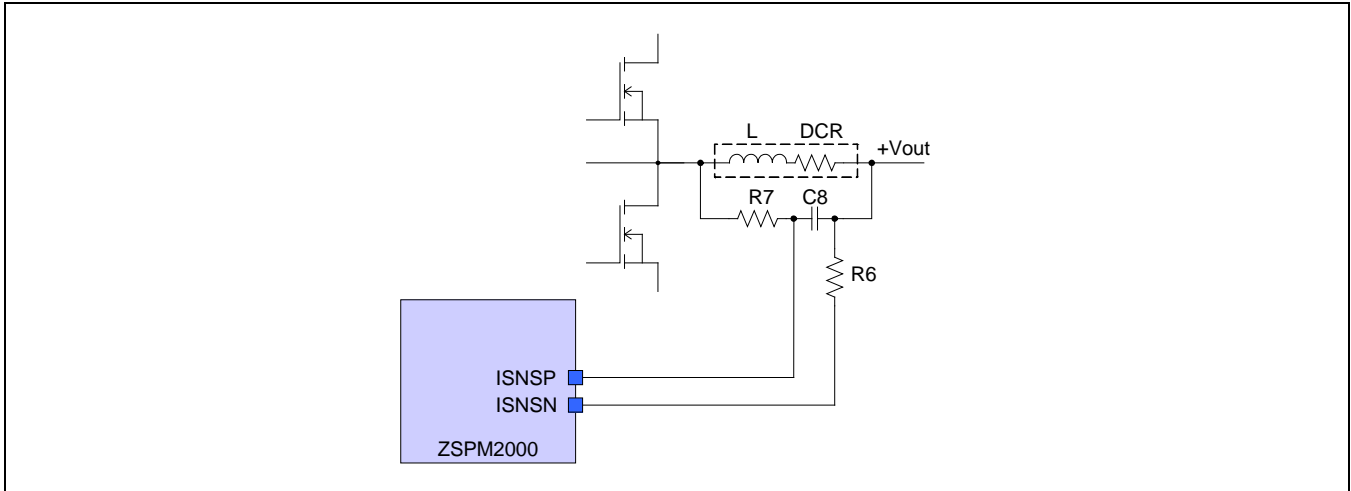


**Table 5.1** Output Voltage Feedback Component Overview

Nominal Output Voltage	Maximum Output Voltage	R4	R5	C7
1.20V	1.40V	open	1.0kΩ	22pF
1.80V	2.1V	1.5kΩ	750Ω	47pF
2.50V	2.80V	1.0kΩ	1.0kΩ	47pF
3.30V	4.25V	1.0kΩ	2.2kΩ	33pF
5.00V	5.00V	1.0kΩ	3.3kΩ	33pF

## 5.2. DCR Current Sensing Components

Figure 5.2 Inductor Current Sensing Using the DCR Method



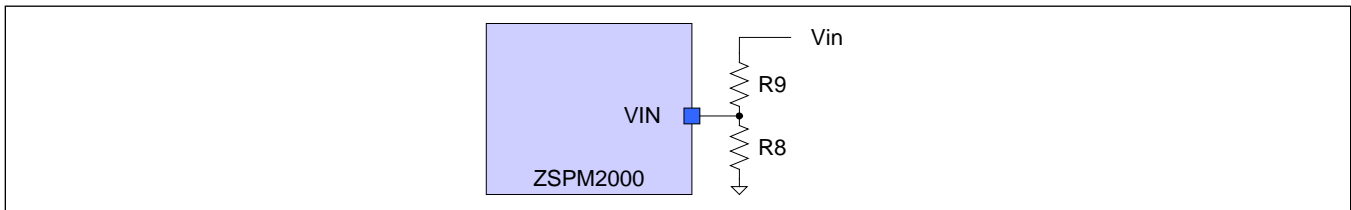
The ZSPM2000 supports the loss-less DCR current sense method. The equivalent DC resistance (DCR) of the inductor is used to measure the inductor current without adding any additional components into the power path. The technique is based on matching the time constants of the inductor and the parallel low-pass filter. Therefore the components R6, R7, and C8 must be selected depending on the selected inductor. The following procedure is recommended:

- 1.) Set  $R7 = 1k\Omega$
- 2.) Calculate  $C8 = L / (DCR * R7)$ .
- 3.) Pick capacitor C8 from the appropriate E-series close to C8.
- 4.) Recalculate  $R6=R7= L / (DCR * C8)$  based on the capacitor selected for C8.

### 5.3. Input Voltage Sensing

The ZSPM2000 supports input voltage sensing for protection and monitoring. Therefore a voltage divider between the input voltage and the VIN pin is required. The recommended resistor values for different input voltage ranges can be found in Table 5.2. For different nominal input voltages, the respective component values with the maximum supported input voltage are listed. Optionally, a capacitor, typically 10nF, can be connected to the VIN pin to help improve accuracy.

**Figure 5.3** Input Voltage Sense Circuitry



**Table 5.2** Input Voltage Sense Component Overview

Nominal Input Voltage	Maximum Input Voltage	R9	R8
12V	14.5V	20kΩ	2.2kΩ
8.0V	9.0V	12kΩ	2.2kΩ
5.0V	6.5V	8.2kΩ	2.2kΩ

## 6 Synchronous MOSFET Driver Features

### 6.1. Introduction

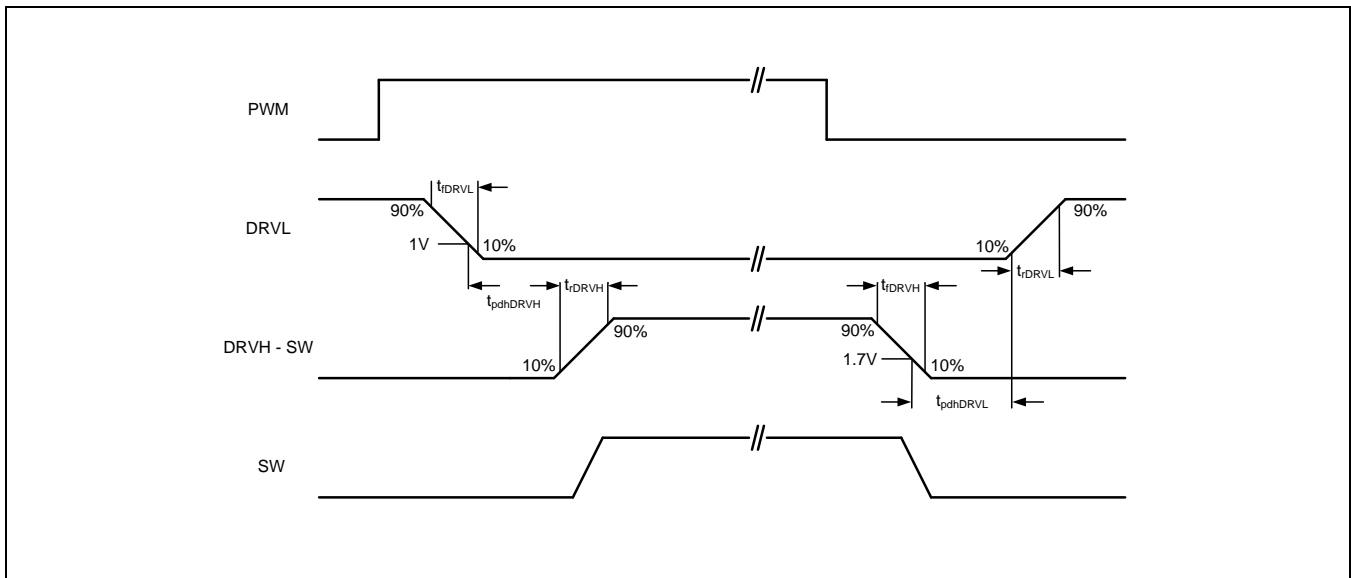
The synchronous MOSFET gate driver of the ZSPM2000 is designed to drive the N-channel MOSFETs of a low voltage step-down converter. The driver supply voltage (VDD50DRV) is 5V, and the driver is capable of driving a 3nF load. The input under-voltage lockout function guarantees the outputs are low when the supply voltage is low.

### 6.2. Adaptive Non-overlap Dead-Time Control

Adaptive dead-time control is used to avoid shoot-through damage of the power MOSFETs. See section 1.3 for the timing specifications for this function, which are illustrated in Figure 6.1. When the internal PWM signal pulls high, the driver will monitor the gate voltage of the low side MOSFET; i.e., the DRVL pin of the ZSPM2000. When the DRVL voltage falls below the gate threshold, DRVH will be set to high after the  $t_{pdhDRVH}$  delay. When the PWM is set low, DRVH will be set low, and the driver will monitor the gate voltage of the high-side MOSFET. When the voltage between the DRVH and SW pins falls below the top gate drive threshold, DRVL will be set to high after the  $t_{pdhDRVL}$  delay.

**Figure 6.1 Adaptive Non-overlap Dead-Time Control Timing Diagram**

Note: the PWM signal is internal.



### 6.3. Layout Guidelines

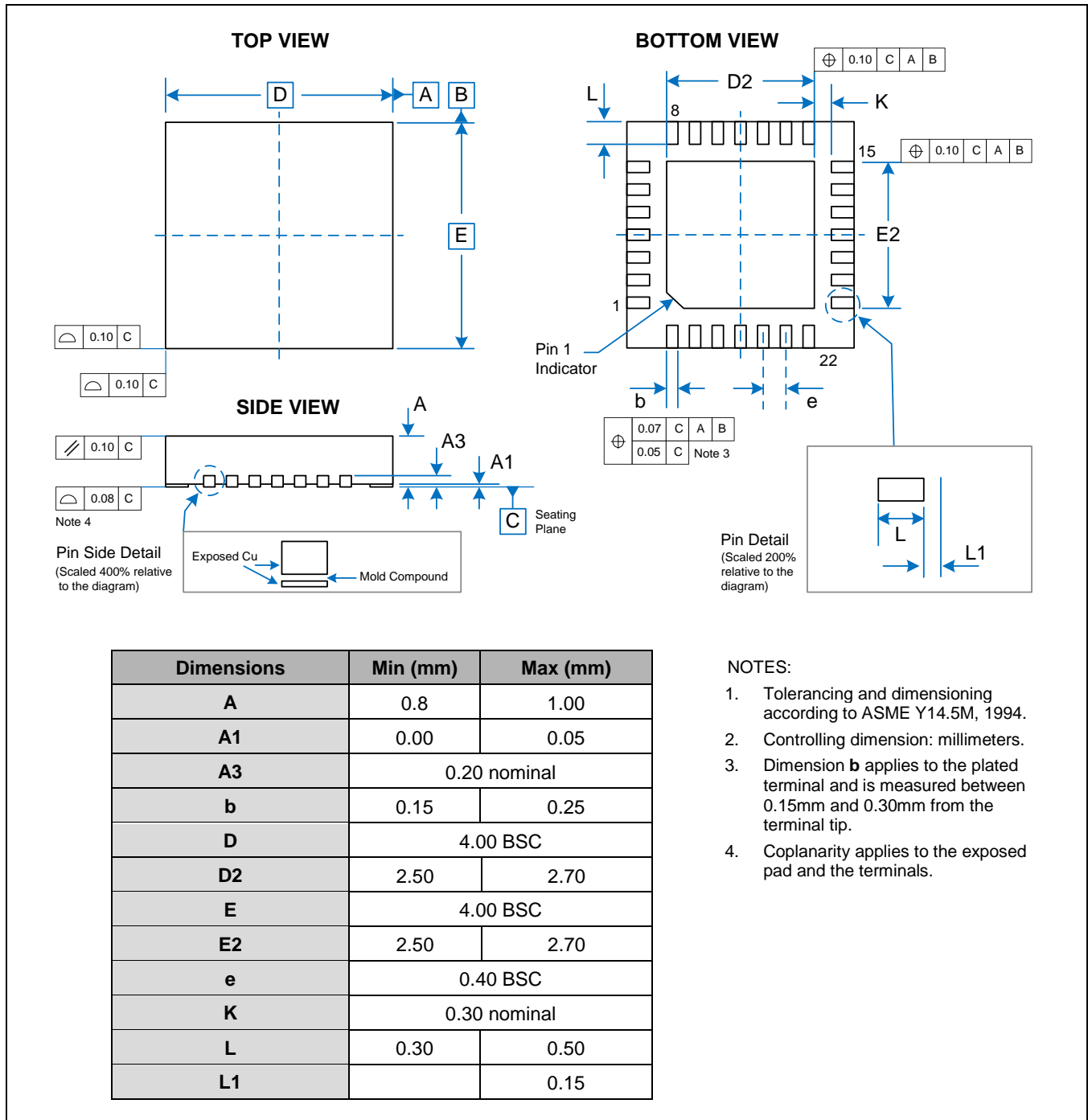
Layout of the point-of-load (POL) converter PCB is very important. The bootstrap (BST) pin and VDD50DRV pin decoupling capacitors should be placed as close as possible to the ZSPM2000. The VDD50DRV bypass capacitor should be connected to the PGND pin of the ZSPM2000.

Connect the PGND pin to the ground plane of the power stage. The ground plane can provide a good return path for the gate drive current and reduce the ground noise. To minimize the ground loop for the low-side MOSFET, place the PGND pin close to the source pin of the low-side MOSFET. The gate drive traces should be routed to minimize the length; the recommended minimum width is 20 mils.

## 7 Mechanical Specifications

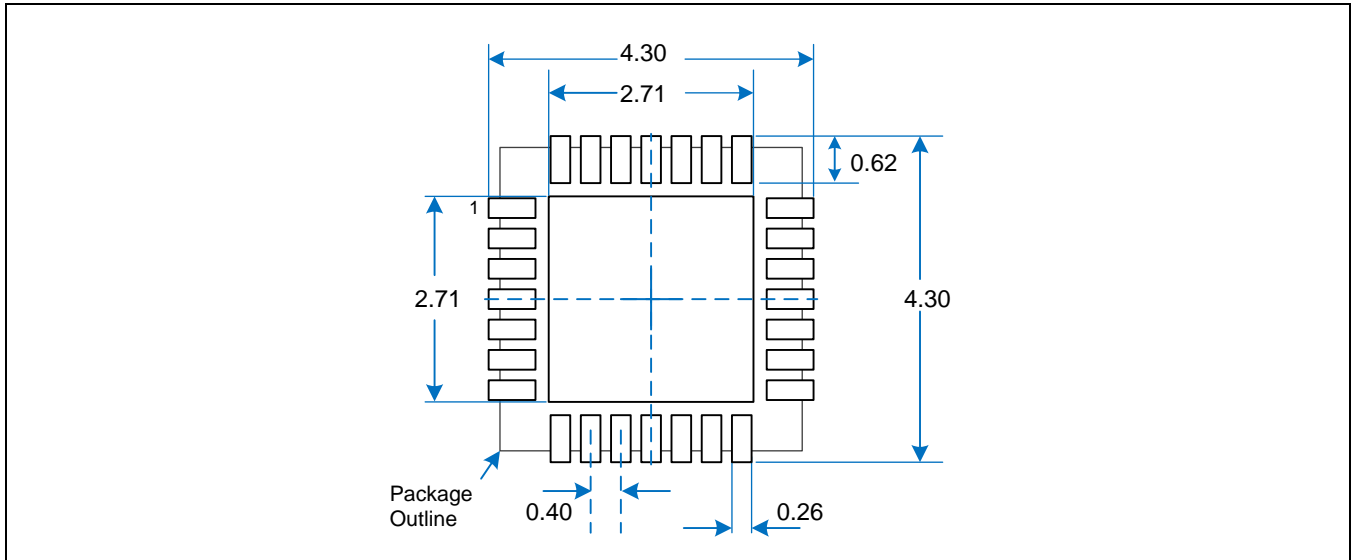
Based on JEDEC MO-220. All dimensions are in millimeters.

Figure 7.1 28-Pin QFN Package Drawing

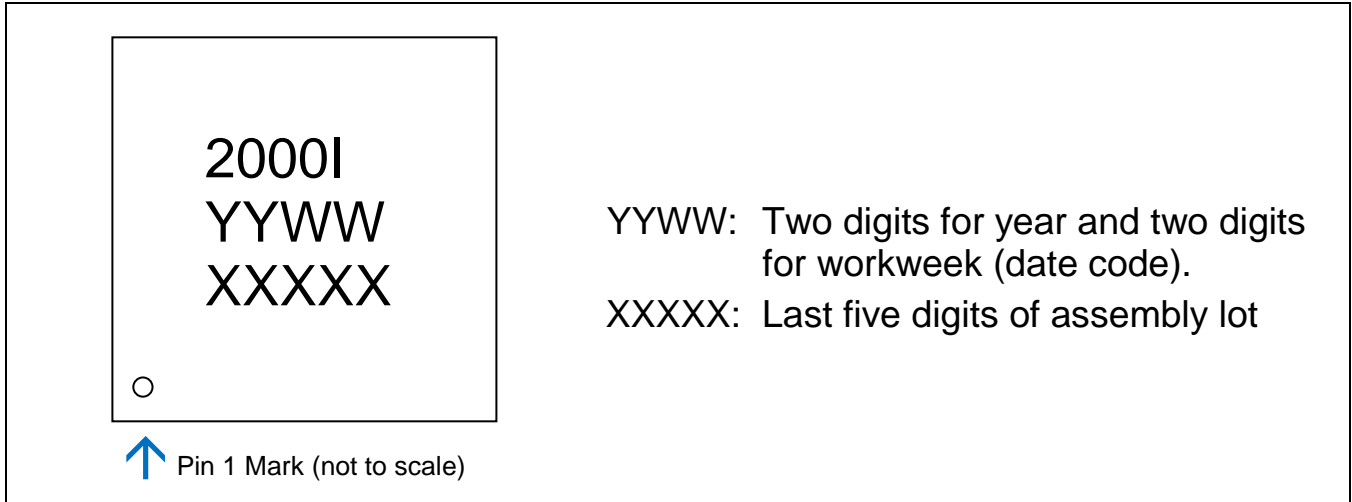


**Figure 7.2 28-Pin QFN Recommended Mounting Footprint**

All dimensions are in millimeters.



**Figure 7.3 Top Marking Diagram**





## 8 Ordering Information

Note: This product is sold under a limited license from PowerOne, Inc. related to digital power technology as set forth in U.S. Patent 7000125 and other related patents owned by PowerOne, Inc. This license does not extend to standalone power supply products.

Product Sales Code	Description	Package
ZSPM2000ZI2R 1	ZSPM2000 Lead-free QFN28 — Temperature range: -40°C to +85°C	Reel
ZSPM2000-KIT01	Evaluation Kit for ZSPM2000 with PMBus™ Communication Interface — the Pink Power Designer™ GUI for kit can be downloaded from the IDT web site at <a href="http://www.IDT.com/ZSPM2000">www.IDT.com/ZSPM2000</a> (login required; see data sheet section 9 for details)	Kit

## 9 Related Documents

Document
ZSPM2000 Feature Sheet
ZSPM1000/ZSPM2000 Pink Power Designer™ Graphic User Interface (GUI) *
ZSPM100x/ZSPM200x Application Note—Programming and Calibration *
ZSPM2000-KIT01 Kit Description *

Visit the ZSPM2000 product page [www.IDT.com/ZSPM2000](http://www.IDT.com/ZSPM2000) or contact your nearest sales office for the latest version of these documents.

Note: Documents marked with an asterisk (\*) require a free customer login account.

## 10 Glossary

Term	Description
ASIC	Application Specific Integrated Circuit
DCR	Equivalent DC Resistance
DPWM	Digital Pulse-Width Modulator
DSP	Digital Signal Processing
FPGA	Field-Programmable Gate Array
GPIO	General Purpose Input/Output
GUI	Graphical User Interface
HKADC	Housekeeping Analog-To-Digital Converter
NVM	Non-volatile Memory
OT	Over-Temperature
OTP	One-Time Programmable Memory

Term	Description
OV	Over-Voltage
PEC	Packet Error Correction
PID	Proportional/Integral/Derivative
POL	Point-of-Load
SCL	Serial Clock
SCR	Sub-cycle Response™
SDA	Serial Data
SLC	State-Law Control™
SPM	Smart Power Management

## 11 Document Revision History

Revision	Date	Description
1.00	November 16, 2014	First release.
1.01	March 4, 2015	Correction for hyperlink to product page web address. Update for Korean address and sales e-mail address in contact information.
	January 27, 2016	Changed to IDT branding.

## IMPORTANT NOTICE AND DISCLAIMER

RENESAS ELECTRONICS CORPORATION AND ITS SUBSIDIARIES (“RENESAS”) PROVIDES TECHNICAL SPECIFICATIONS AND RELIABILITY DATA (INCLUDING DATASHEETS), DESIGN RESOURCES (INCLUDING REFERENCE DESIGNS), APPLICATION OR OTHER DESIGN ADVICE, WEB TOOLS, SAFETY INFORMATION, AND OTHER RESOURCES “AS IS” AND WITH ALL FAULTS, AND DISCLAIMS ALL WARRANTIES, EXPRESS OR IMPLIED, INCLUDING, WITHOUT LIMITATION, ANY IMPLIED WARRANTIES OF MERCHANTABILITY, FITNESS FOR A PARTICULAR PURPOSE, OR NON-INFRINGEMENT OF THIRD-PARTY INTELLECTUAL PROPERTY RIGHTS.

These resources are intended for developers who are designing with Renesas products. You are solely responsible for (1) selecting the appropriate products for your application, (2) designing, validating, and testing your application, and (3) ensuring your application meets applicable standards, and any other safety, security, or other requirements. These resources are subject to change without notice. Renesas grants you permission to use these resources only to develop an application that uses Renesas products. Other reproduction or use of these resources is strictly prohibited. No license is granted to any other Renesas intellectual property or to any third-party intellectual property. Renesas disclaims responsibility for, and you will fully indemnify Renesas and its representatives against, any claims, damages, costs, losses, or liabilities arising from your use of these resources. Renesas' products are provided only subject to Renesas' Terms and Conditions of Sale or other applicable terms agreed to in writing. No use of any Renesas resources expands or otherwise alters any applicable warranties or warranty disclaimers for these products.

(Disclaimer Rev.1.01 Jan 2024)

### Corporate Headquarters

TOYOSU FORESIA, 3-2-24 Toyosu,  
Koto-ku, Tokyo 135-0061, Japan  
[www.renesas.com](http://www.renesas.com)

### Trademarks

Renesas and the Renesas logo are trademarks of Renesas Electronics Corporation. All trademarks and registered trademarks are the property of their respective owners.

### Contact Information

For further information on a product, technology, the most up-to-date version of a document, or your nearest sales office, please visit [www.renesas.com/contact-us/](http://www.renesas.com/contact-us/).