

X9401

Low Noise/Low Power/SPI Bus Quad, 64 Tap, Digitally Controlled Potentiometer (XDCP™)

FN8190
Rev 5.00
September 14, 2015

Description

The X9401 integrates 4 digitally controlled potentiometers (XDCP) on a monolithic CMOS integrated microcircuit.

The digitally controlled potentiometer is implemented using 64 resistive elements in a series array. Between each element are tap points connected to the wiper terminal through switches. The position of the wiper on the array is controlled by the user through the SPI bus interface. Each potentiometer has associated with it a volatile Wiper Counter Register (WCR) and 4 nonvolatile Data Registers (DR0:DR3) that can be directly written to and read by the user. The contents of the WCR controls the position of the wiper on the resistor array through the switches. Power-up recalls the contents of DR0 to the WCR.

The XDCP can be used as a three-terminal potentiometer or as a two-terminal variable resistor in a wide variety of applications including control, parameter adjustments, and signal processing.

Features

- Quad - 4 Separate Pots, 64 Taps/Pot
- Nonvolatile Storage of Wiper Position
- Four Nonvolatile Data Registers for Each Pot
- 16-bytes of EEPROM Memory
- SPI Serial Interface
- $R_{TOTAL} = 10k\Omega$
- Wiper Resistance = 150Ω Typical
- Standby Current < $3\mu A$ (Total Package)
- Operating Current < $700\mu A$ max.
- $V_{CC} = 2.7V$ to $5V$
- 24 Ld SOIC and 24 Ld TSSOP Package
- 100 year Data Retention
- Pb-Free Available (RoHS Compliant)

Block Diagram

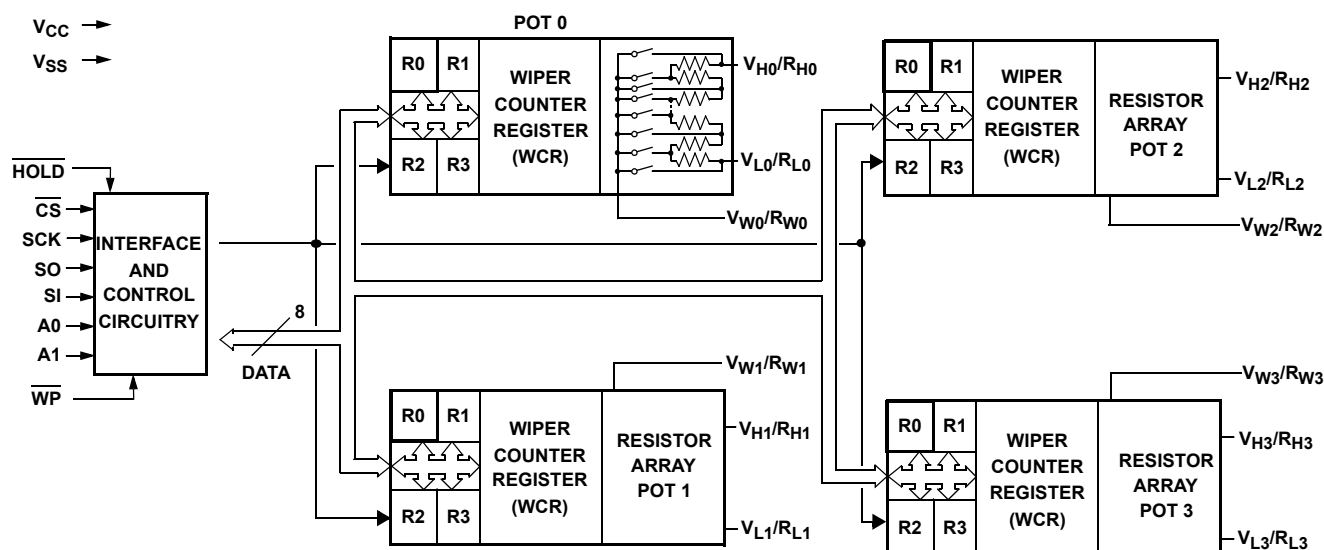

Ordering Information

PART NUMBER	PART MARKING	V _{CC} LIMITS (V)	POTENTIOMETER ORGANIZATION (k Ω)	TEMP RANGE (°C)	PACKAGE	PKG. DWG. #
X9401WS24IZ* (Note 1) (No longer available, recommended replacement: X9401WS24IZ-2.7T1)	X9401WS ZI	5 \pm 10%	10	-40 to +85	24 Ld SOIC (300 mil) (Pb-free)	M24.3
X9401WS24Z* (Note 1) (No longer available, recommended replacement: X9401WS24IZ-2.7T1)	X9401WS Z			-40 to +85	24 Ld SOIC (300 mil)	M24.3
X9401WV24IZ* (Note 1) (No longer available, recommended replacement: X9401WV24IZ-2.7T1)	X9401WV ZI			-40 to +85	24 Ld TSSOP (4.4mm) (Pb-free)	MDP0044
X9401WV24Z* (Note 1) (No longer available, recommended replacement: X9401WV24IZ-2.7T1)	X9401WV Z			-40 to +85	24 Ld TSSOP (4.4mm) (Pb-free)	MDP0044
X9401WS24IZ-2.7* (Note)	X9401WS ZG	2.7 to 5.5		-40 to +85	24 Ld SOIC (300 mil) (Pb-free)	M24.3
X9401WS24Z-2.7* (Note 1) (No longer available, recommended replacement: X9401WS24IZ-2.7T1)	X9401WS ZF			-40 to +85	24 Ld SOIC (300 mil) (Pb-free)	M24.3
X9401WV24IZ-2.7* (Note 1)	X9401WV ZG			-40 to +85	24 Ld TSSOP (4.4mm) (Pb-free)	MDP0044
X9401WV24Z-2.7* (Note 1) (No longer available, recommended replacement: X9401WV24IZ-2.7T1)	X9401WV ZF			-40 to +85	24 Ld TSSOP (4.4mm) (Pb-free)	MDP0044

*Add "T1" suffix for tape and reel. Please refer to TB347 for details on reel specifications.

NOTES:

- These Intersil Pb-free plastic packaged products employ special Pb-free material sets, molding compounds/die attach materials, and 100% matte tin plate plus anneal (e3 termination finish, which is RoHS compliant and compatible with both SnPb and Pb-free soldering operations). Intersil Pb-free products are MSL classified at Pb-free peak reflow temperatures that meet or exceed the Pb-free requirements of IPC/JEDEC J STD-020.
- Not recommended for new designs.

Pin Descriptions

Host Interface Pins

SERIAL OUTPUT (SO)

SO is a push/pull serial data output pin. During a read cycle, data is shifted out on this pin. Data is clocked out by the falling edge of the serial clock.

SERIAL INPUT

SI is the serial data input pin. All opcodes, byte addresses and data to be written to the pots and pot registers are input on this pin. Data is latched by the rising edge of the serial clock.

SERIAL CLOCK (SCK)

The SCK input is used to clock data into and out of the X9401.

CHIP SELECT (\overline{CS})

When \overline{CS} is HIGH, the X9401 is deselected and the SO pin is at high impedance, and (unless an internal write cycle is underway) the device will be in the standby state. \overline{CS} LOW enables the X9401, placing it in the active power mode. It should be noted that after a power-up, a HIGH to LOW transition on \overline{CS} is required prior to the start of any operation.

HOLD ($\overline{\text{HOLD}}$)

$\overline{\text{HOLD}}$ is used in conjunction with the $\overline{\text{CS}}$ pin to select the device. Once the part is selected and a serial sequence is underway, $\overline{\text{HOLD}}$ may be used to pause the serial communication with the controller without resetting the serial sequence. To pause, $\overline{\text{HOLD}}$ must be brought LOW while SCK is LOW. To resume communication, $\overline{\text{HOLD}}$ is brought HIGH, again while SCK is LOW. If the pause feature is not used, $\overline{\text{HOLD}}$ should be held HIGH at all times.

DEVICE ADDRESS ($A_0 - A_1$)

The address inputs are used to set the least significant 2 bits of the 8-bit slave address. A match in the slave address serial data stream must be made with the address input in order to initiate communication with the X9401. A maximum of 4 devices may occupy the SPI serial bus.

Potentiometer Pins

V_H ($V_{H0} - V_{H3}$) / R_H ($R_{H0} - R_{H3}$),

V_L ($V_{L0} - V_{L3}$) / R_L ($R_{L0} - R_{L3}$)

The V_H/R_H and V_L/R_L inputs are equivalent to the terminal connections on either end of a mechanical potentiometer.

VW ($VW_0 - VW_3$) / RW ($RW_0 - RW_3$)

The wiper outputs are equivalent to the wiper output of a mechanical potentiometer.

HARDWARE WRITE PROTECT INPUT ($\overline{\text{WP}}$)

The $\overline{\text{WP}}$ pin when LOW prevents nonvolatile writes to the Wiper Counter Registers.

Pinouts

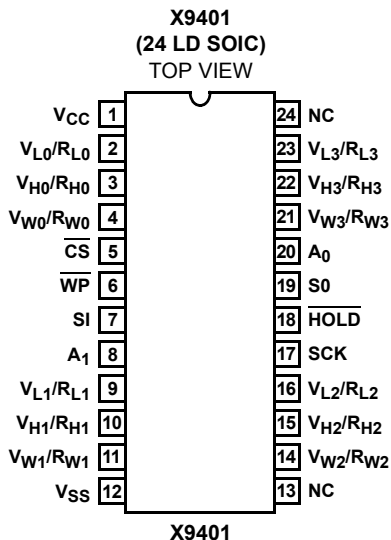

(24 LD TSSOP)
TOP VIEW

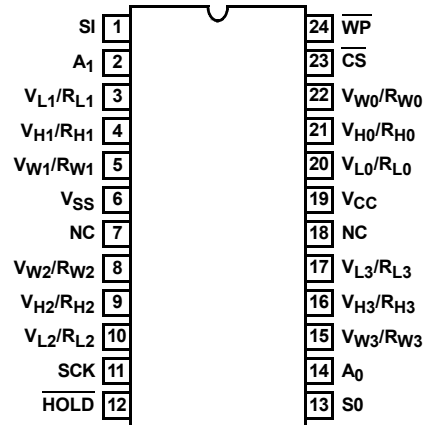

Pin Descriptions

SOIC PIN #	TSSOP PIN #	SYMBOL	DESCRIPTION
5	23	$\overline{\text{CS}}$	Chip select
17	11	SCK	Serial Clock
7, 19	1, 13	SI, S0	Serial Data
20, 8	14, 2	$A_0 - A_1$	Device Address
3, 10, 15, 22, 2, 9, 16, 23	21, 4, 9, 16, 20, 3, 10, 17	$V_{H0}/R_{H0}, V_{H1}/R_{H1}, V_{H2}/R_{H2}, V_{H3}/R_{H3}, V_{L0}/R_{L0}, V_{L1}/R_{L1}, V_{L2}/R_{L2}, V_{L3}/R_{L3}$	Potentiometer end terminals
4, 11, 14, 21	22, 5, 8, 15	$V_{W0}/R_{W0}, V_{W1}/R_{W1}, V_{W2}/R_{W2}, V_{W3}/R_{W3}$	Wipers
6	24	$\overline{\text{WP}}$	Hardware Write Protection
18	12	$\overline{\text{HOLD}}$	Hardware Hold
1	19	V_{CC}	System Supply Voltage
12	6	V_{SS}	System Ground
13, 24	7, 18	NC	No Connection

Device Description

The X9401 is a highly integrated microcircuit incorporating four resistor arrays and their associated registers and counters and the serial interface logic providing direct communication between the host and the XDCP potentiometers.

Serial Interface

The X9401 supports the SPI interface hardware conventions. The device is accessed via the SI input with data clocked in on the rising SCK. $\overline{\text{CS}}$ must be LOW and the $\overline{\text{HOLD}}$ and $\overline{\text{WP}}$ pins must be HIGH during the entire operation.

The SO and SI pins can be connected together, since they have three state outputs. This can help to reduce system pin count.

Array Description

The X9401 is comprised of four resistor arrays. Each array contains 63 discrete resistive segments that are connected in

series. The physical ends of each array are equivalent to the fixed terminals of a mechanical potentiometer (V_H/R_H and V_L/R_L inputs).

At both ends of each array and between each resistor segment is a CMOS switch connected to the wiper (V_W/R_W) output. Within each individual array only one switch may be turned on at a time.

These switches are controlled by a Wiper Counter Register (WCR). The six bits of the WCR are decoded to select, and enable, one of sixty-four switches.

Wiper Counter Register (WCR)

The X9401 contains four Wiper Counter Registers, one for each XDCP potentiometer. The WCR is equivalent to a serial-in, parallel-out register/counter with its outputs decoded to select one of sixty-four switches along its resistor array. The contents of the WCR can be altered in four ways: it may be written directly by the host via the Write Wiper Counter Register instruction (serial load); it may be written indirectly by transferring the contents of one of four associated data registers via the XFR Data Register or Global XFR Data Register instructions (parallel load); it can be modified one step at a time by the Increment/Decrement instruction. Finally, it is loaded with the contents of its data register zero (R0) upon power-up.

The Wiper Counter Register is a volatile register; that is, its contents are lost when the X9401 is powered-down. Although the register is automatically loaded with the value in R0 upon power-up, this may be different from the value present at power-down. The wiper position must be stored in R0 to insure restoring the wiper position after power-up.

Data Registers

Each potentiometer has four 6-bit nonvolatile data registers. These can be read or written directly by the host. Data can also be transferred between any of the four data registers and the associated Wiper Counter Register. All operations changing data in one of the data registers is a nonvolatile operation and will take a maximum of 10ms.

If the application does not require storage of multiple settings for the potentiometer, the data registers can be used as memory locations for system parameters or user preference data.

DATA REGISTER DETAIL

(MSB)						(LSB)
D5	D4	D3	D2	D1	D0	
NV	NV	NV	NV	NV	NV	

Write in Process

The contents of the Data Registers are saved to nonvolatile memory when the \overline{CS} pin goes from LOW to HIGH after a complete write sequence is received by the device. The

progress of this internal write operation can be monitored by a Write In Process bit (WIP). The WIP bit is read with a Read Status command.

Instructions

Identification (ID) Byte

The first byte sent to the X9401 from the host, following a \overline{CS} going HIGH to LOW, is called the Identification byte. The most significant four bits of the slave address are a device type identifier. For the X9401 this is fixed as 0101[B] (refer to Figure 1).

The two least significant bits in the ID byte select one of four devices on the bus. The physical device address is defined by the state of the $A_0 - A_1$ input pins. The X9401 compares the serial data stream with the address input state; a successful compare of both address bits is required for the X9401 to successfully continue the command sequence. The $A_0 - A_1$ inputs can be actively driven by CMOS input signals or tied to V_{CC} or V_{SS} . The remaining two bits in the slave byte must be set to 0.

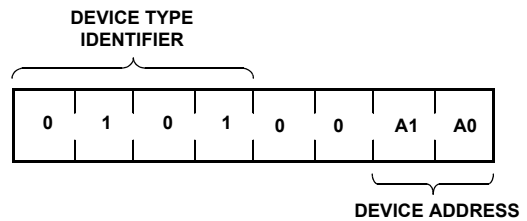

FIGURE 1. IDENTIFICATION BYTE FORMAT

Instruction Byte

The next byte sent to the X9401 contains the instruction and register pointer information. The four most significant bits are the instruction. The next four bits point to one of the four pots and, when applicable, they point to one of four associated registers. The format is shown below in Figure 2.

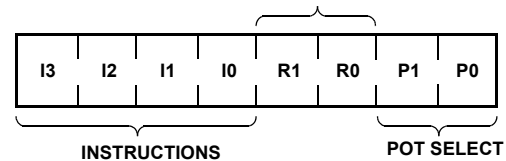

FIGURE 2. IDENTIFICATION BYTE FORMAT

The four high order bits of the instruction byte specify the operation. The next two bits (R_1 and R_0) select one of the four registers that is to be acted upon when a register oriented instruction is issued. The last two bits (P_1 and P_0) selects which one of the four potentiometers is to be affected by the instruction.

Four of the ten instructions are two bytes in length and end with the transmission of the instruction byte. These instructions are:

- XFR Data Register to Wiper Counter Register: This transfers the contents of one specified Data Register to the associated Wiper Counter Register.
- XFR Wiper Counter Register to Data Register: This transfers the contents of the specified Wiper Counter Register to the specified associated Data Register.
- Global XFR Data Register to Wiper Counter Register: This transfers the contents of all specified Data Registers to the associated Wiper Counter Registers.
- Global XFR Wiper Counter Register to Data Register: This transfers the contents of all Wiper Counter Registers to the specified associated Data Registers.

The basic sequence of the two byte instructions is illustrated in Figure 3. These two-byte instructions exchange data between the WCR and one of the data registers. A transfer from a data register to a WCR is essentially a write to a static RAM, with the static RAM controlling the wiper position. The response of the wiper to this action will be delayed by t_{WRL} . A transfer from the WCR (current wiper position), to a data register is a write to nonvolatile memory and takes a minimum of t_{WR} to complete. The transfer can occur between one of the four potentiometers and one of its associated registers; or it may occur globally, where the transfer occurs between all potentiometers and one associated register.

Five instructions require a three-byte sequence to complete. These instructions transfer data between the host and the X9401; either between the host and one of the data registers or directly between the host and the Wiper Counter Register. These instructions are:

- Read Wiper Counter Register: read the current wiper position of the selected pot,
- Write Wiper Counter Register: change current wiper position of the selected pot,
- Read Data Register: read the contents of the selected data register;
- Write Data Register: write a new value to the selected data register.
- Read Status: This command returns the contents of the WIP bit which indicates if the internal write cycle is in progress.

The sequence of these operations is shown in Figure 4 and Figure 5.

The final command is Increment/Decrement. It is different from the other commands, because its length is indeterminate. Once the command is issued, the master can clock the selected wiper up and/or down in one resistor segment steps; thereby, providing a fine tuning capability to the host. For each SCK clock pulse (t_{HIGH}) while SI is HIGH, the selected wiper will move one resistor segment towards the V_H/R_H terminal.

Similarly, for each SCK clock pulse while SI is LOW, the selected wiper will move one resistor segment towards the V_L/R_L terminal. A detailed illustration of the sequence and timing for this operation are shown in Figure 6 and Figure 7.

Detailed Potentiometer Block Diagram

(ONE OF FOUR ARRAYS)

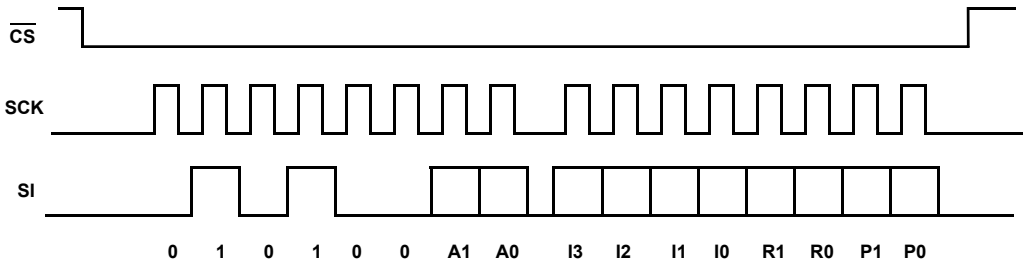
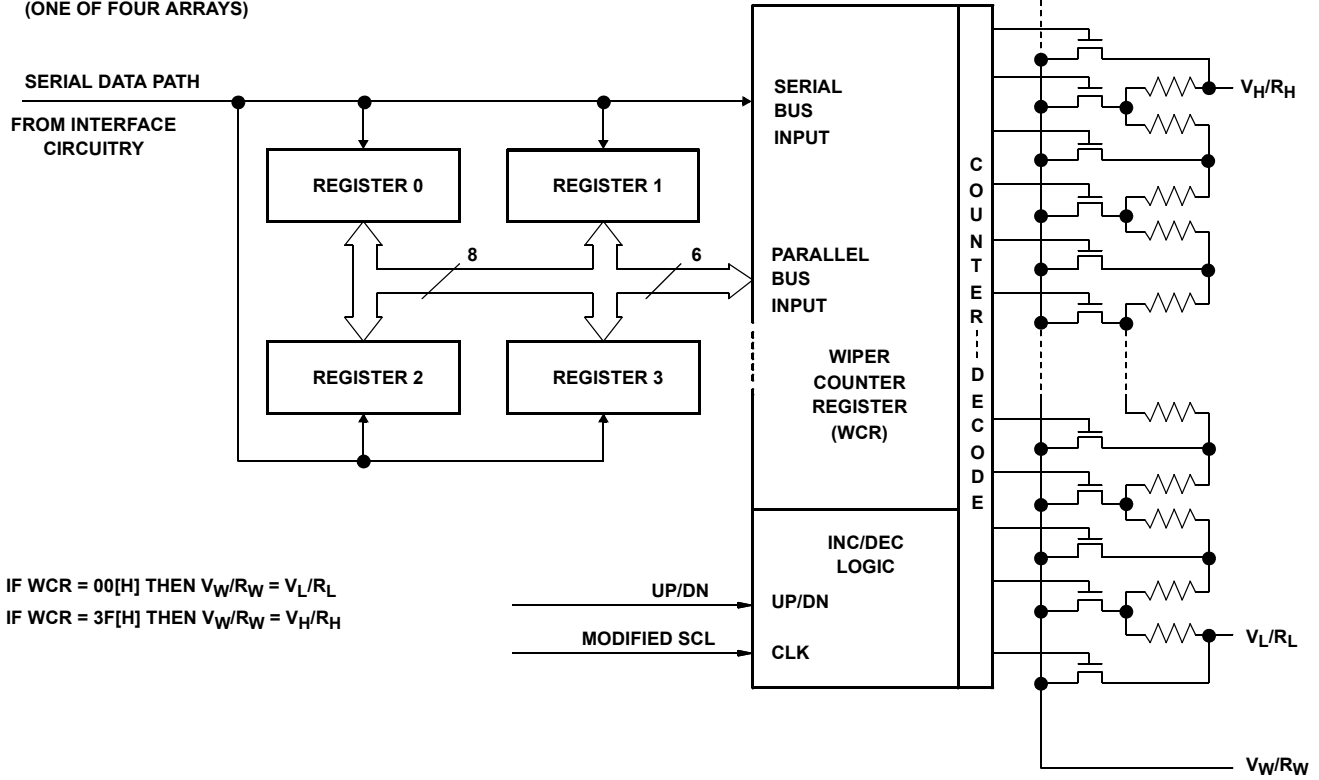

FIGURE 3. TWO-BYTE COMMAND SEQUENCE

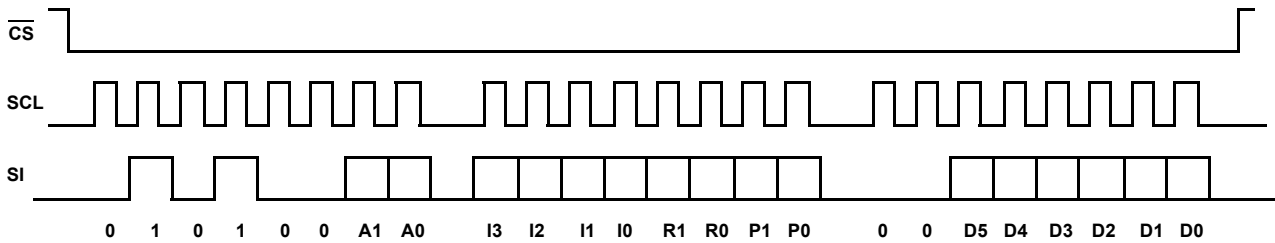

FIGURE 4. THREE-BYTE COMMAND SEQUENCE (WRITE)

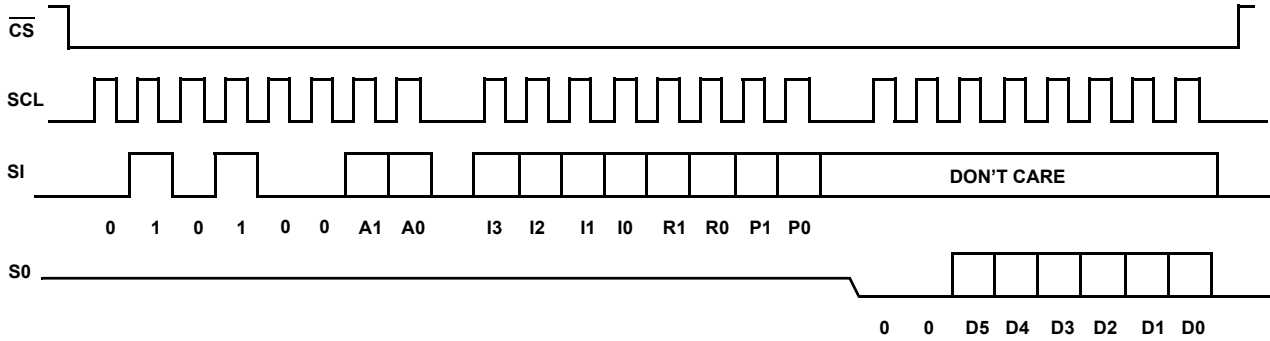

FIGURE 5. THREE-BYTE COMMAND SEQUENCE (READ)

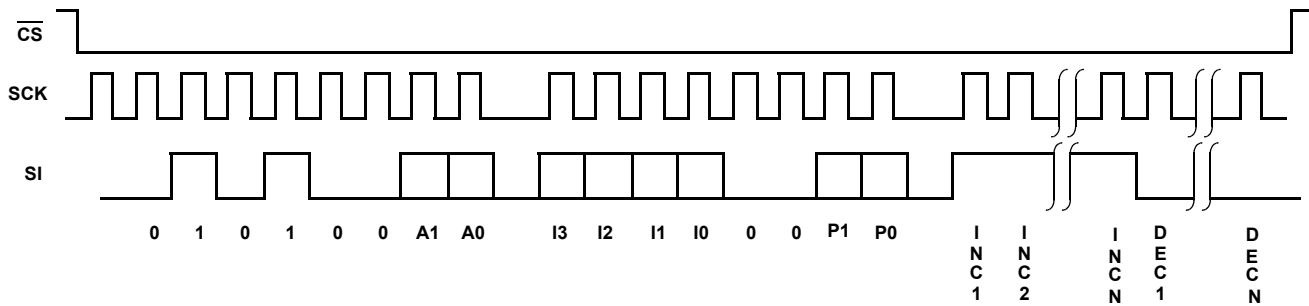

FIGURE 6. INCREMENT/DECREMENT COMMAND SEQUENCE

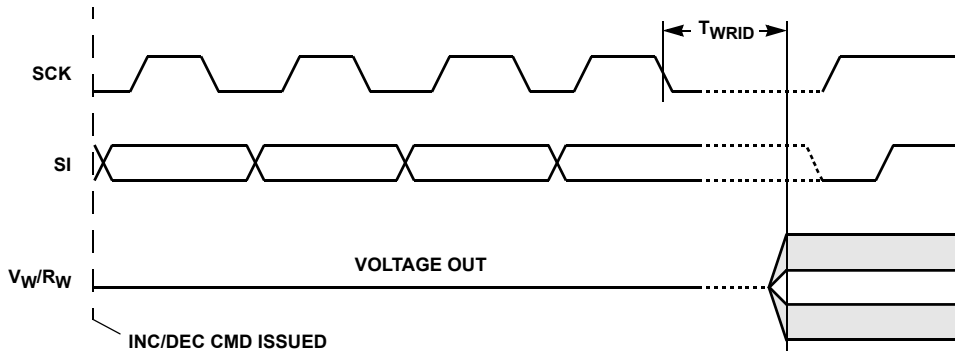

FIGURE 7. INCREMENT/DECREMENT TIMING LIMITS

TABLE 1. INSTRUCTION SET

INSTRUCTION	INSTRUCTION SET								OPERATION
	I ₃	I ₂	I ₁	I ₀	R ₁	R ₀	P ₁	P ₀	
Read Wiper Counter Register	1	0	0	1	0	0	P ₁	P ₀	Read the contents of the Wiper Counter Register pointed to by P ₁ - P ₀
Write Wiper Counter Register	1	0	1	0	0	0	P ₁	P ₀	Write new value to the Wiper Counter Register pointed to by P ₁ - P ₀
Read Data Register	1	0	1	1	R ₁	R ₀	P ₁	P ₀	Read the contents of the Data Register pointed to by P ₁ - P ₀ and R ₁ - R ₀
Write Data Register	1	1	0	0	R ₁	R ₀	P ₁	P ₀	Write new value to the Data Register pointed to by P ₁ - P ₀ and R ₁ - R ₀
XFR Data Register to Wiper Counter Register	1	1	0	1	R ₁	R ₀	P ₁	P ₀	Transfer the contents of the Data Register pointed to by R ₁ - R ₀ to the Wiper Counter Register pointed to by P ₁ - P ₀

TABLE 1. INSTRUCTION SET

INSTRUCTION	INSTRUCTION SET								OPERATION
	I ₃	I ₂	I ₁	I ₀	R ₁	R ₀	P ₁	P ₀	
XFR Wiper Counter Register to Data Register	1	1	1	0	R ₁	R ₀	P ₁	P ₀	Transfer the contents of the Wiper Counter Register pointed to by P ₁ - P ₀ to the Register pointed to by R ₁ - R ₀
Global XFR Data Register to Wiper Counter Register	0	0	0	1	R ₁	R ₀	0	0	Transfer the contents of the Data Registers pointed to by R ₁ - R ₀ of all four pots to their respective Wiper Counter Register
Global XFR Wiper Counter Register to Data Register	1	0	0	0	R ₁	R ₀	0	0	Transfer the contents of all Wiper Counter Registers to their respective data Registers pointed to by R ₁ - R ₀ of all four pots
Increment/Decrement Wiper Counter Register	0	0	1	0	0	0	P ₁	P ₀	Enable Increment/decrement of the Wiper Counter Register pointed to by P ₁ - P ₀
Read Status (WIP bit)	0	1	0	1	0	0	0	1	Read the status of the internal write cycle, by checking the WIP bit.

Instruction Format

NOTES:

3. A1 ~ A0": stands for the device addresses sent by the master.
4. WPx refers to wiper position data in the Counter Register
5. "I": stands for the increment operation, SI held HIGH during active SCK phase (high).
6. "D": stands for the decrement operation, SI held LOW during active SCK phase (high).

Read Wiper Counter Register (WCR)

$\overline{\text{CS}}$ FALLING EDGE	DEVICE TYPE IDENTIFIER				DEVICE ADDRESSES			INSTRUCTION OPCODE				WCR ADDRESSES				WIPER POSITION (SENT BY X9401 ON SO)						$\overline{\text{CS}}$ RISING EDGE			
	0	1	0	1	0	0	A1	A0	1	0	0	1	0	0	P1	P0	0	0	WP5	WP4	WP3		WP2	WP1	WP0
	0	1	0	1	0	0	A1	A0	1	0	0	1	0	0	P1	P0	0	0	WP5	WP4	WP3	WP2	WP1	WP0	

Write Wiper Counter Register (WCR)

$\overline{\text{CS}}$ FALLING EDGE	DEVICE TYPE IDENTIFIER				DEVICE ADDRESSES			INSTRUCTION OPCODE				WCR ADDRESSES				DATA BYTE (SENT BY HOST ON SI)						$\overline{\text{CS}}$ RISING EDGE			
	0	1	0	1	0	0	A1	A0	1	0	1	0	0	0	P1	P0	0	0	WP5	WP4	WP3		WP2	WP1	WP0
	0	1	0	1	0	0	A1	A0	1	0	1	0	0	0	P1	P0	0	0	WP5	WP4	WP3	WP2	WP1	WP0	

Read Data Register (DR)

$\overline{\text{CS}}$ FALLING EDGE	DEVICE TYPE IDENTIFIER				DEVICE ADDRESSES			INSTRUCTION OPCODE				DR AND WCR ADDRESSES				DATA BYTE (SENT BY X9401 ON SO)						$\overline{\text{CS}}$ RISING EDGE			
	0	1	0	1	0	0	A1	A0	1	0	1	1	R1	R0	P1	P0	0	0	WP5	WP4	WP3		WP2	WP1	WP0
	0	1	0	1	0	0	A1	A0	1	0	1	1	R1	R0	P1	P0	0	0	WP5	WP4	WP3	WP2	WP1	WP0	

Write Data Register (DR)

$\overline{\text{CS}}$ FALLING EDGE	DEVICE TYPE IDENTIFIER				DEVICE ADDRESSES			INSTRUCTION OPCODE				DR AND WCR ADDRESSES				DATA BYTE (SENT BY HOST ON SI)						$\overline{\text{CS}}$ RISING EDGE	HIGH-VOLTAGE WRITE CYCLE			
	0	1	0	1	0	0	A1	A0	1	1	0	0	R1	R0	P1	P0	0	0	WP5	WP4	WP3			WP2	WP1	WP0
	0	1	0	1	0	0	A1	A0	1	1	0	0	R1	R0	P1	P0	0	0	WP5	WP4	WP3	WP2	WP1	WP0		

Transfer Data Register (DR) to Wiper Counter Register (WCR)

$\overline{\text{CS}}$ FALLING EDGE	DEVICE TYPE IDENTIFIER				DEVICE ADDRESSES			INSTRUCTION OPCODE				DR AND WCR ADDRESSES				$\overline{\text{CS}}$ RISING EDGE	
	0	1	0	1	0	0	A1	A0	1	1	0	1	R1	R0	P1		P0
	0	1	0	1	0	0	A1	A0	1	1	0	1	R1	R0	P1	P0	

Transfer Wiper Counter Register (WCR) to Data Register (DR)

$\overline{\text{CS}}$ FALLING EDGE	DEVICE TYPE IDENTIFIER				DEVICE ADDRESSES			INSTRUCTION OPCODE				DR AND WCR ADDRESSES				$\overline{\text{CS}}$ RISING EDGE	HIGH-VOLTAGE WRITE CYCLE	
	0	1	0	1	0	0	A1	A0	1	1	1	0	R1	R0	P1			P0
	0	1	0	1	0	0	A1	A0	1	1	1	0	R1	R0	P1	P0		

Increment/Decrement Wiper Counter Register (WCR)

$\overline{\text{CS}}$ FALLING EDGE	DEVICE TYPE IDENTIFIER				DEVICE ADDRESSES			INSTRUCTION OPCODE				WCR ADDRESSES				INCREMENT/DECREMENT (SENT BY MASTER ON SDA)				$\overline{\text{CS}}$ RISING EDGE					
	0	1	0	1	0	0	A1	A0	0	0	1	0	X	X	P1	P0	I/D	I/D	I/D	I/D
	0	1	0	1	0	0	A1	A0	0	0	1	0	X	X	P1	P0	I/D	I/D	I/D	I/D	

Global Transfer Data Register (DR) to Wiper Counter Register (WCR)

$\overline{\text{CS}}$ FALLING EDGE	DEVICE TYPE IDENTIFIER				DEVICE ADDRESSES			INSTRUCTION OPCODE				DR ADDRESSES				$\overline{\text{CS}}$ RISING EDGE	
	0	1	0	1	0	0	A1	A0	0	0	0	1	R1	R0	0		0
	0	1	0	1	0	0	A1	A0	0	0	0	1	R1	R0	0	0	

Global Transfer Wiper Counter Register (WCR) to Data Register (DR)

$\overline{\text{CS}}$ FALLING EDGE	DEVICE TYPE IDENTIFIER				DEVICE ADDRESSES				INSTRUCTION OPCODE				DR ADDRESSES				$\overline{\text{CS}}$ RISING EDGE	HIGH-VOLTAGE WRITE CYCLE
	0	1	0	1	0	0	A1	A0	1	0	0	0	R1	R0	0	0		
	0	1	0	1	0	0	A1	A0	1	0	0	0	R1	R0	0	0		

Read Status

$\overline{\text{CS}}$ FALLING EDGE	DEVICE TYPE IDENTIFIER				DEVICE ADDRESSES				INSTRUCTION OPCODE				WIPER ADDRESSES				DATA BYTE (SENT BY X9401 ON SO)								$\overline{\text{CS}}$ RISING EDGE	
	0	1	0	1	0	0	A1	A0	0	1	0	1	0	0	0	1	0	0	0	0	0	0	0	0		WIP
	0	1	0	1	0	0	A1	A0	0	1	0	1	0	0	0	1	0	0	0	0	0	0	0	0	WIP	

Absolute Maximum Ratings

Supply Voltage (V_{CC} Limits)	
X9401	5V \pm 10%
X9401-2.7	2.7V to 5.5V
Voltage on SCK, SCL or any address input with respect to V_{SS} :	-1V to +7V
$\Delta V = (V_H - V_L) $	5.5V

Thermal Information

Temperature Under Bias	-65°C to +135°C
Storage Temperature	-65°C to +150°C
Pb-Free Reflow Profile	see link below http://www.intersil.com/pbfree/Pb-FreeReflow.asp

Operating Conditions

Temperature Range	
Commercial	0°C to +70°C
Industrial	-40°C to +85°C

CAUTION: Do not operate at or near the maximum ratings listed for extended periods of time. Exposure to such conditions may adversely impact product reliability and result in failures not covered by warranty.

Analog Specifications (Over recommended operating conditions unless otherwise stated.)

SYMBOL	PARAMETER	TEST CONDITION	MIN (Note 10)	TYP	MAX (Note 10)	UNIT
R_{TOTAL}	End to End resistance Tolerance		-20		+20	%
	Power Rating	+25°C, each pot			50	mW
I_W	Wiper Current		-6		+6	mA
R_W	Wiper Resistance	$I_W = (V_H - V_L)/R_{TOTAL}$ $V_{CC} = 5V$		150	500	Ω
V_{TERM}	Voltage on any V_H or V_L Pin		V_{SS}		V_{CC}	V
	Noise	Ref: 1kHz		-120		dBV
	Resolution			1.6		%
	Absolute Linearity (Note 7)	$V_{W(n)(actual)} - V_{W(n)(expected)}$	-1		+1	MI (Note 9)
	Relative Linearity (Note 8)	$V_{W(n+1)} - [V_{W(n)} + MI]$	-0.2		+0.2	MI (Note 9)
	Temperature Coefficient of R_{TOTAL}	$V(R_H) = V_{CC}$, $V(R_L) = V_{SS}$			± 300	ppm/°C
	Ratiometric Temperature Coefficient			± 20	ppm/°C	
$C_H/C_L/C_W$	Potentiometer Capacitances	See Macro model		10/10/25		pF
I_{AL}	R_H , R_L , R_W Leakage Current	$V_{IN} = V_{SS}$ Device is in Stand-by mode.		0.1	10	μA

NOTES:

- Absolute linearity is utilized to determine actual wiper voltage versus expected voltage as determined by wiper position when used as a potentiometer.
- Relative linearity is utilized to determine the actual change in voltage between two successive tap positions when used as a potentiometer. It is a measure of the error in step size.
- MI = $RTOT/63$ or $(V_H - V_L)/63$, single pot.
- Parameters with MIN and/or MAX limits are 100% tested at +25°C, unless otherwise specified. Temperature limits established by characterization and are not production tested.

Power-up and Down Requirements

There are no restrictions on the power-up or power-down conditions of V_{CC} and the voltages applied to the potentiometer pins provided that V_{CC} is always more positive than or equal to V_H , V_L , and V_W , i.e., $V_{CC} \geq V_H$, V_L , V_W . The V_{CC} power-up spec is always in effect.

DC Operating Characteristics (Over the recommended operating conditions unless otherwise specified.)

SYMBOL	PARAMETER	TEST CONDITIONS	MIN (Note 10)	TYP	MAX (Note 10)	UNIT
I _{CC1}	V _{CC} Supply Current (active)	f _{SCK} = 2MHz, SO = Open, Other Inputs = V _{SS}			700	μA
I _{CC2}	V _{CC} Supply Current (non-volatile write)	f _{SCK} = 2MHz, SO = Open, Other Inputs = V _{SS}			3	mA
I _{SB}	V _{CC} Current (standby)	SCK = SI = V _{SS} , Addr. = V _{SS} , CS = V _{CC}			3	μA
I _{LI}	Input Leakage Current	V _{IN} = V _{SS} to V _{CC}			10	μA
I _{LO}	Output Leakage Current	V _{OUT} = V _{SS} to V _{CC}			10	μA
V _{IH}	Input HIGH Voltage		V _{CC} × 0.7		V _{CC} + 0.5	V
V _{IL}	Input LOW Voltage		-0.5		V _{CC} × 0.1	V
V _{OL}	Output LOW Voltage	I _{OL} = 3mA			0.4	V

Endurance and Data Retention

PARAMETER	MIN.	UNIT
Minimum endurance	100,000	Data changes per bit per register
Data retention	100	years

Capacitance

SYMBOL	TEST	TYP.	UNIT	TEST CONDITION
C _{OUT} (Note 11)	Output capacitance (SO)	8	pF	V _{OUT} = 0V
C _{IN} (Note 11)	Input capacitance (A0, A1, SI, and SCK)	6	pF	V _{IN} = 0V

Power-up Timing Input pulse levels = V_{CC} × 0.1 to V_{CC} × 0.9; Input rise and fall times = 10ns; Input and output timing level = V_{CC} × 0.5.

SYMBOL	PARAMETER	MIN.	MAX.	UNIT
t _r V _{CC} (Note 11)	V _{CC} Power-up rate	0.2	50	V/ms
t _{PUR} (Note 12)	Power-up to initiation of read operation		1	ms
t _{PUW} (Note 12)	Power-up to initiation of write operation		5	ms

NOTES:

- This parameter is not 100% tested.
- t_{PUR} and t_{PUW} are the delays required from the time the (last) power supply (V_{CC-}) is stable until the specific instruction can be issued. These parameters are periodically sampled and not 100% tested.

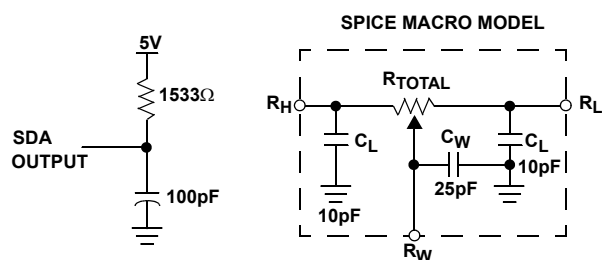
Equivalent AC Load Circuit

AC Timing

SYMBOL	PARAMETER	MIN. (Note 10)	MAX. (Note 10)	UNIT
f_{SCK}	SSI/SPI clock frequency		2.0	MHz
t_{CYC}	SSI/SPI clock cycle time	500		ns
t_{WH}	SSI/SPI clock high time	200		ns
t_{WL}	SSI/SPI clock low time	200		ns
t_{LEAD}	Lead time	250		ns
t_{LAG}	Lag time	250		ns
t_{SU}	SI, SCK, \overline{HOLD} and \overline{CS} input setup time	50		ns
t_H	SI, SCK, \overline{HOLD} and \overline{CS} input hold time	50		ns
t_{RI}	SI, SCK, \overline{HOLD} and \overline{CS} input rise time		2	μ s
t_{FI}	SI, SCK, \overline{HOLD} and \overline{CS} input fall time		2	μ s
t_{DIS}	SO output disable time	0	500	ns
t_V	SO output valid time		150	ns
t_{HO}	SO output hold time	0		ns
t_{RO}	SO output rise time		50	ns
t_{FO}	SO output fall time		50	ns
t_{HOLD}	\overline{HOLD} time	400		ns
t_{HSU}	\overline{HOLD} setup time	100		ns
t_{HH}	\overline{HOLD} hold time	100		ns
t_{HZ}	\overline{HOLD} low to output in high Z		100	ns
t_{LZ}	\overline{HOLD} high to output in low Z		100	ns
T_I	Noise suppression time constant at SI, SCK, \overline{HOLD} and \overline{CS} inputs		20	ns
t_{CS}	\overline{CS} deselect time	2		μ s
t_{WPASU}	\overline{WP} , A0 and A1 setup time	0		ns
t_{WPAH}	\overline{WP} , A0 and A1 hold time	0		ns

High-voltage Write Cycle Timing

SYMBOL	PARAMETER	TYP	MAX (Note 10)	UNIT
t_{WR}	High-voltage write cycle time (store instructions)	5	10	ms

XDCP Timing

SYMBOL	PARAMETER	MIN.	MAX. (Note 10)	UNIT
t_{WRPO}	Wiper response time after the third (last) power supply is stable		10	μ s
t_{WRL}	Wiper response time after instruction issued (all load instructions)		10	μ s
t_{WRID}	Wiper response time from an active SCL/SCK edge (increment/decrement instruction)		450	ns

Symbol Table

WAVEFORM	INPUTS	OUTPUTS
	MUST BE STEADY	WILL BE STEADY
	MAY CHANGE FROM LOW TO HIGH	WILL CHANGE FROM LOW TO HIGH
	MAY CHANGE FROM HIGH TO LOW	WILL CHANGE FROM HIGH TO LOW
	DON'T CARE: CHANGES ALLOWED	CHANGING: STATE NOT KNOWN
	N/A	CENTER LINE IS HIGH IMPEDANCE

Timing Diagrams

Input Timing

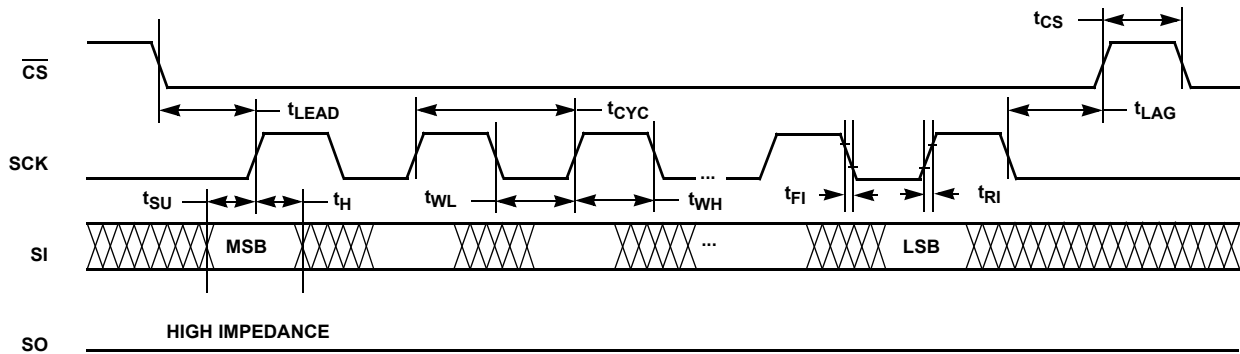

Output Timing

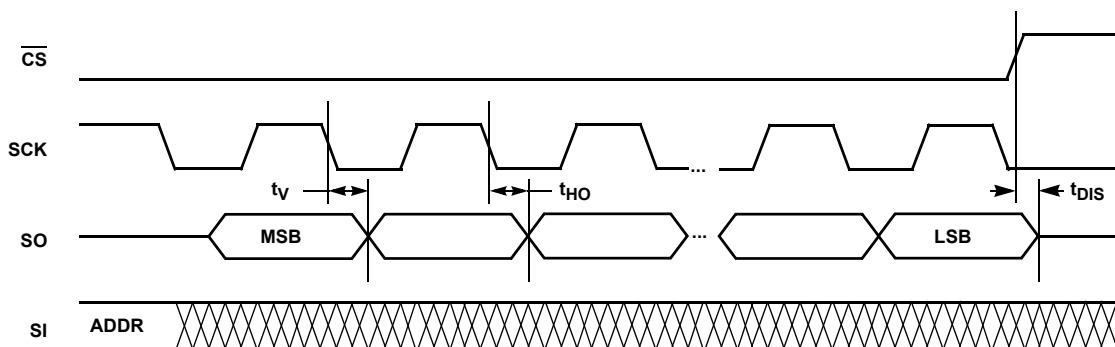

Hold Timing

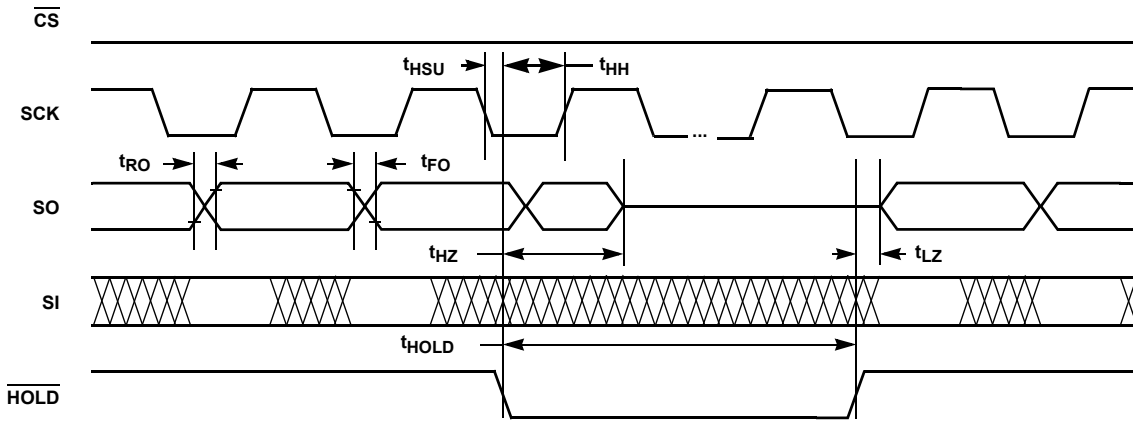

XDCP Timing (for All Load Instructions)

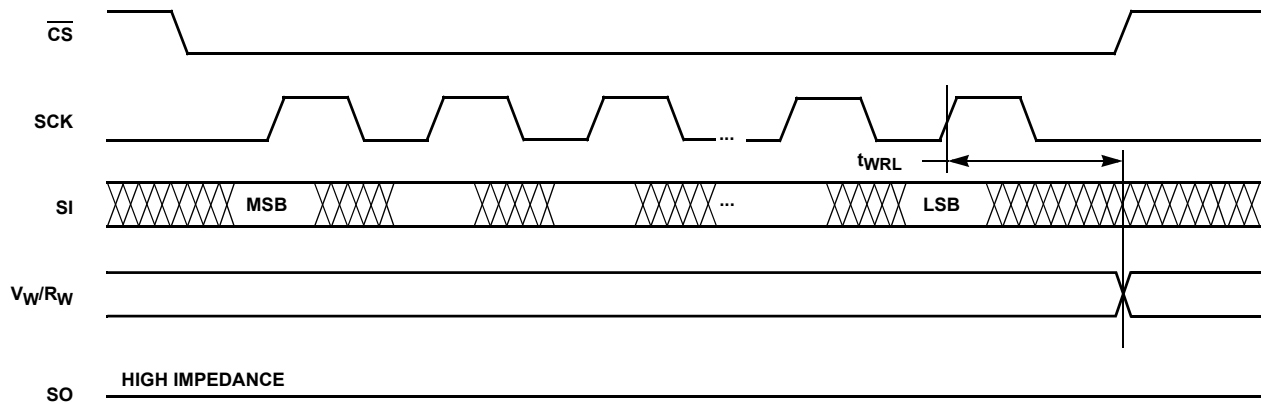

XDCP Timing (for Increment/Decrement Instruction)

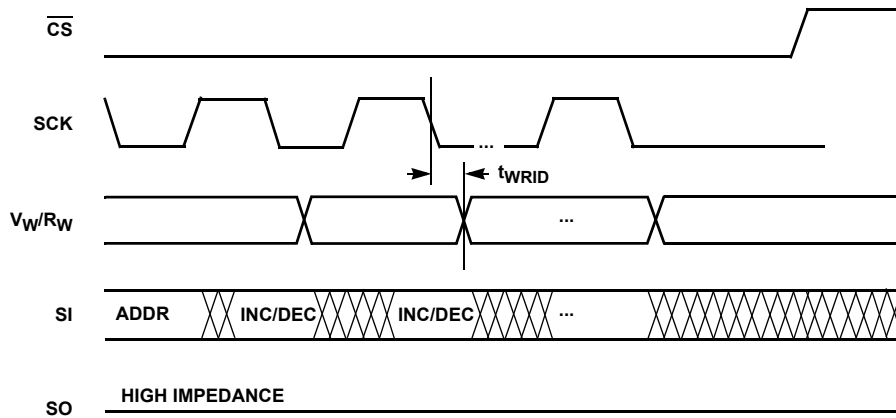

Write Protect and Device Address Pins Timing

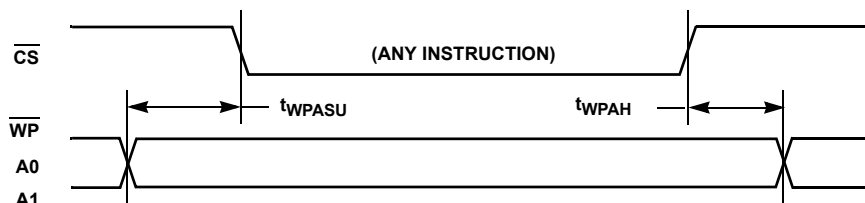

Applications information

Basic Configurations of Electronic Potentiometers

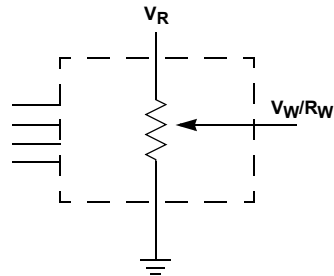

THREE TERMINAL POTENTIOMETER;
VARIABLE VOLTAGE DIVIDER

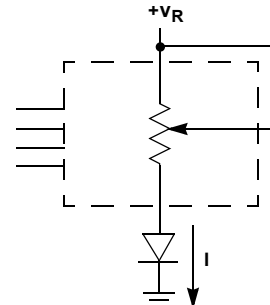

TWO TERMINAL VARIABLE RESISTOR;
VARIABLE CURRENT

Application Circuits

NONINVERTING AMPLIFIER

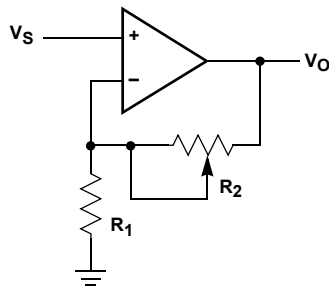

$$V_O = (1 + R_2/R_1)V_S$$

VOLTAGE REGULATOR

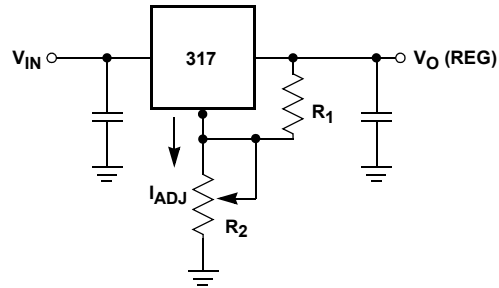

$$V_O (\text{REG}) = 1.25V (1 + R_2/R_1) + I_{\text{ADJ}} R_2$$

OFFSET VOLTAGE ADJUSTMENT

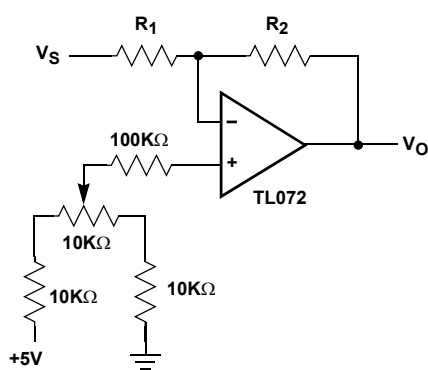

COMPARATOR WITH HYSTERESIS

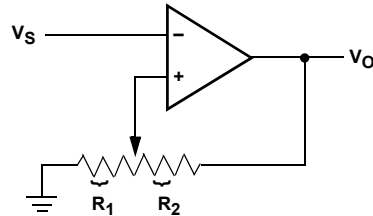

$$V_{UL} = \{R_1/(R_1 + R_2)\} V_O (\text{MAX})$$

$$V_{LL} = \{R_1/(R_1 + R_2)\} V_O (\text{MIN})$$

ATTENUATOR

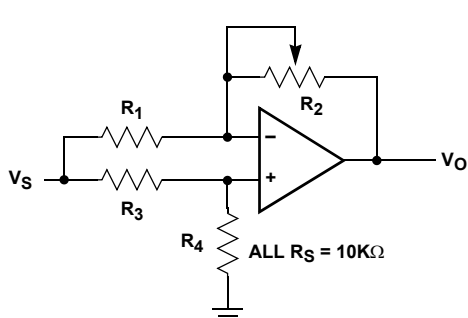

$$V_O = G V_S$$

$$-1/2 \leq G \leq +1/2$$

FILTER

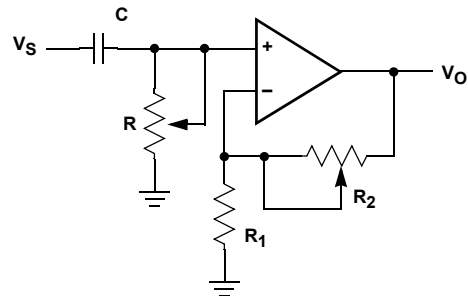

$$G_O = 1 + R_2/R_1$$

$$f_c = 1/(2\pi RC)$$

Application Circuits (continued)

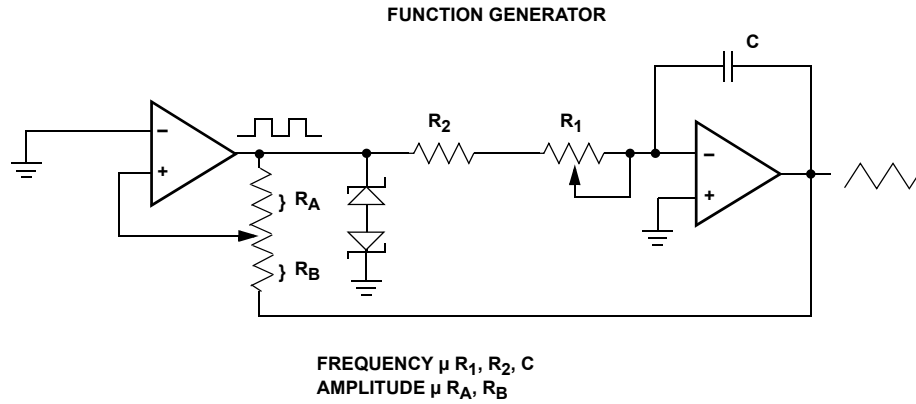
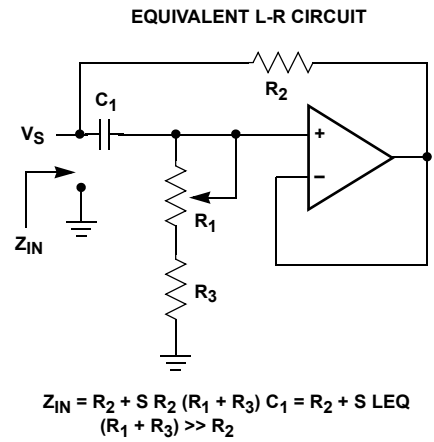
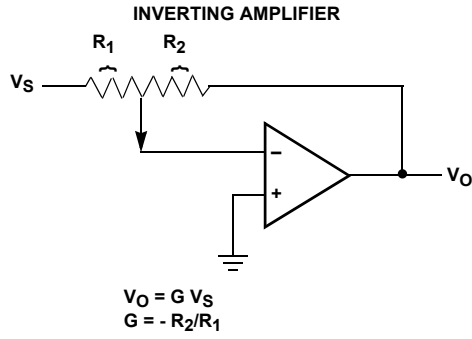

Revision History

The revision history provided is for informational purposes only and is believed to be accurate, but not warranted. Please go to the web to make sure that you have the latest revision.

DATE	REVISION	CHANGE
September 14, 2015	FN8190.5	<ul style="list-style-type: none">- Ordering Information Table on page 2.- Added Revision History.- Added About Intersil Verbiage.- Updated POD M24.3 to most current version change is as follows: Updated to new POD standard by removing table listing dimensions and putting dimensions on drawing. Added Land Pattern.

About Intersil

Intersil Corporation is a leading provider of innovative power management and precision analog solutions. The company's products address some of the largest markets within the industrial and infrastructure, mobile computing and high-end consumer markets.

For the most updated datasheet, application notes, related documentation and related parts, please see the respective product information page found at www.intersil.com.

You may report errors or suggestions for improving this datasheet by visiting www.intersil.com/ask.

Reliability reports are also available from our website at www.intersil.com/support.

Package Outline Drawing

M24.3

24 LEAD WIDE BODY SMALL OUTLINE PLASTIC PACKAGE (SOIC)

Rev 2, 3/11

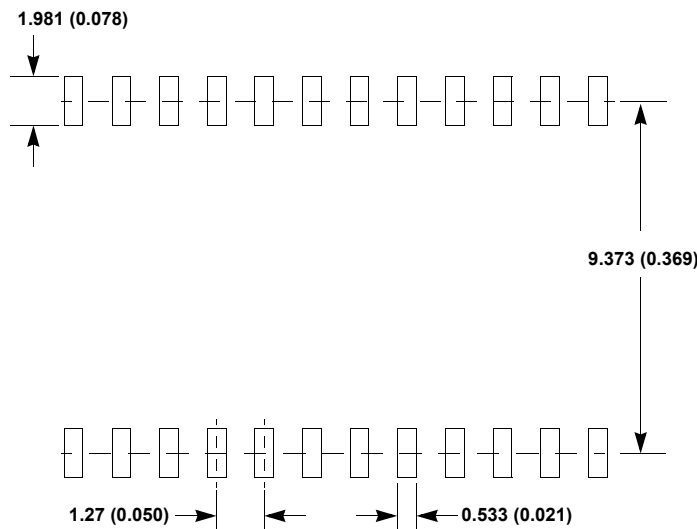
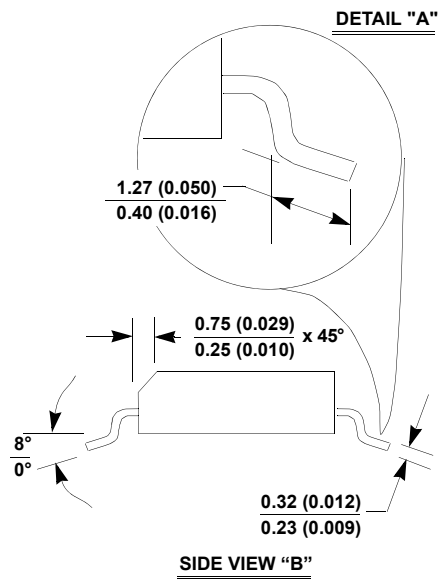
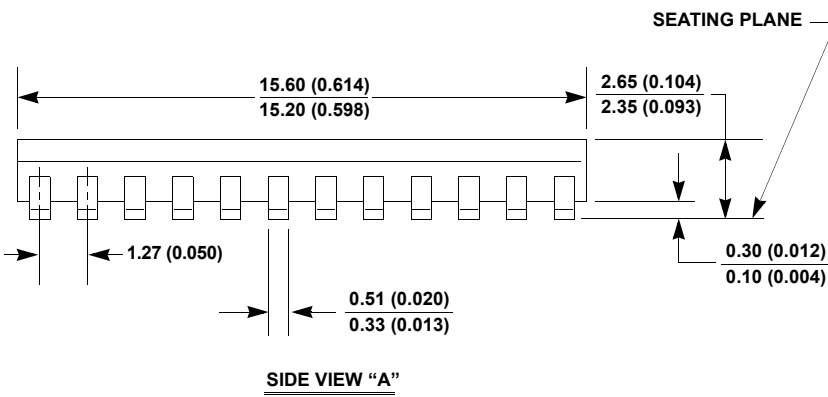
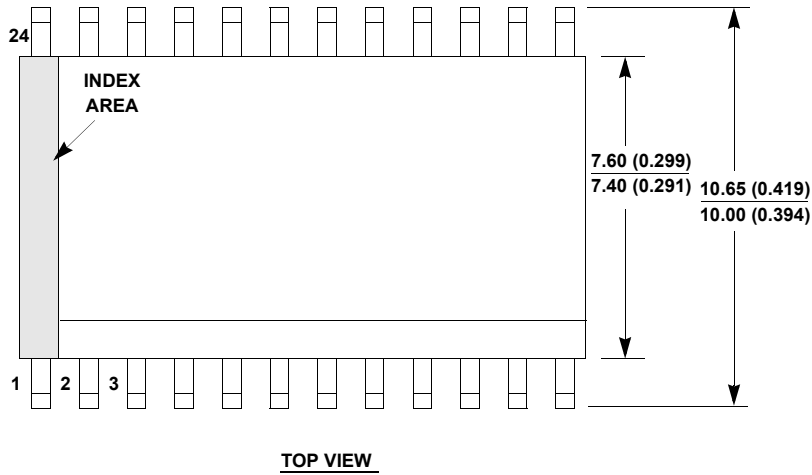

NOTES:

1. Dimensioning and tolerancing per ANSI Y14.5M-1982.
2. Package length does not include mold flash, protrusions or gate burrs. Mold flash, protrusion and gate burrs shall not exceed 0.15mm (0.006 inch) per side.
3. Package width does not include interlead flash or protrusions. Interlead flash and protrusions shall not exceed 0.25mm (0.010 inch) per side.
4. The chamfer on the body is optional. If it is not present, a visual index feature must be located within the crosshatched area.
5. Terminal numbers are shown for reference only.
6. The lead width as measured 0.36mm (0.014 inch) or greater above the seating plane, shall not exceed a maximum value of 0.61mm (0.024 inch).
7. Controlling dimension: MILLIMETER. Converted inch dimensions in () are not necessarily exact.
8. This outline conforms to JEDEC publication MS-013-AD ISSUE C.

Thin Shrink Small Outline Package Family (TSSOP)

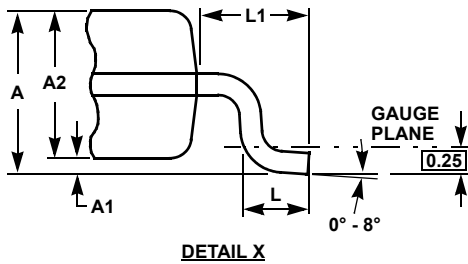
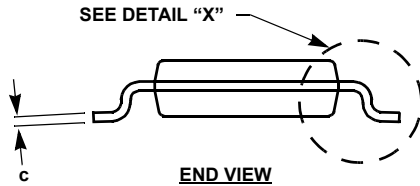
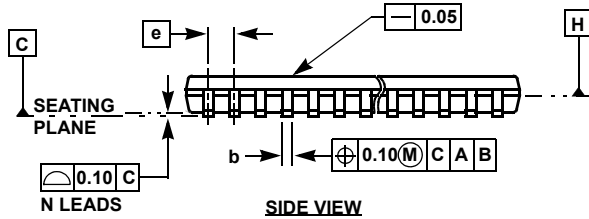
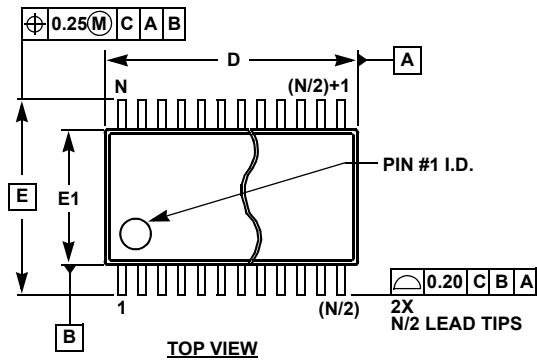

MDP0044

THIN SHRINK SMALL OUTLINE PACKAGE FAMILY

SYMBOL	MILLIMETERS					TOLERANCE
	14 LD	16 LD	20 LD	24 LD	28 LD	
A	1.20	1.20	1.20	1.20	1.20	Max
A1	0.10	0.10	0.10	0.10	0.10	±0.05
A2	0.90	0.90	0.90	0.90	0.90	±0.05
b	0.25	0.25	0.25	0.25	0.25	+0.05/-0.06
c	0.15	0.15	0.15	0.15	0.15	+0.05/-0.06
D	5.00	5.00	6.50	7.80	9.70	±0.10
E	6.40	6.40	6.40	6.40	6.40	Basic
E1	4.40	4.40	4.40	4.40	4.40	±0.10
e	0.65	0.65	0.65	0.65	0.65	Basic
L	0.60	0.60	0.60	0.60	0.60	±0.15
L1	1.00	1.00	1.00	1.00	1.00	Reference

Rev. F 2/07

NOTES:

1. Dimension "D" does not include mold flash, protrusions or gate burrs. Mold flash, protrusions or gate burrs shall not exceed 0.15mm per side.
2. Dimension "E1" does not include interlead flash or protrusions. Interlead flash and protrusions shall not exceed 0.25mm per side.
3. Dimensions "D" and "E1" are measured at dAtum Plane H.
4. Dimensioning and tolerancing per ASME Y14.5M-1994.

© Copyright Intersil Americas LLC 2005-2015. All Rights Reserved.
 All trademarks and registered trademarks are the property of their respective owners.

For additional products, see www.intersil.com/en/products.html

Intersil products are manufactured, assembled and tested utilizing ISO9001 quality systems as noted in the quality certifications found at www.intersil.com/en/support/qualandreliability.html

Intersil products are sold by description only. Intersil may modify the circuit design and/or specifications of products at any time without notice, provided that such modification does not, in Intersil's sole judgment, affect the form, fit or function of the product. Accordingly, the reader is cautioned to verify that datasheets are current before placing orders. Information furnished by Intersil is believed to be accurate and reliable. However, no responsibility is assumed by Intersil or its subsidiaries for its use; nor for any infringements of patents or other rights of third parties which may result from its use. No license is granted by implication or otherwise under any patent or patent rights of Intersil or its subsidiaries.

For information regarding Intersil Corporation and its products, see www.intersil.com