

To our customers,

Old Company Name in Catalogs and Other Documents

On April 1st, 2010, NEC Electronics Corporation merged with Renesas Technology Corporation, and Renesas Electronics Corporation took over all the business of both companies. Therefore, although the old company name remains in this document, it is a valid Renesas Electronics document. We appreciate your understanding.

Renesas Electronics website: <http://www.renesas.com>

April 1st, 2010
Renesas Electronics Corporation

Issued by: Renesas Electronics Corporation (<http://www.renesas.com>)

Send any inquiries to <http://www.renesas.com/inquiry>.

Notice

1. All information included in this document is current as of the date this document is issued. Such information, however, is subject to change without any prior notice. Before purchasing or using any Renesas Electronics products listed herein, please confirm the latest product information with a Renesas Electronics sales office. Also, please pay regular and careful attention to additional and different information to be disclosed by Renesas Electronics such as that disclosed through our website.
2. Renesas Electronics does not assume any liability for infringement of patents, copyrights, or other intellectual property rights of third parties by or arising from the use of Renesas Electronics products or technical information described in this document. No license, express, implied or otherwise, is granted hereby under any patents, copyrights or other intellectual property rights of Renesas Electronics or others.
3. You should not alter, modify, copy, or otherwise misappropriate any Renesas Electronics product, whether in whole or in part.
4. Descriptions of circuits, software and other related information in this document are provided only to illustrate the operation of semiconductor products and application examples. You are fully responsible for the incorporation of these circuits, software, and information in the design of your equipment. Renesas Electronics assumes no responsibility for any losses incurred by you or third parties arising from the use of these circuits, software, or information.
5. When exporting the products or technology described in this document, you should comply with the applicable export control laws and regulations and follow the procedures required by such laws and regulations. You should not use Renesas Electronics products or the technology described in this document for any purpose relating to military applications or use by the military, including but not limited to the development of weapons of mass destruction. Renesas Electronics products and technology may not be used for or incorporated into any products or systems whose manufacture, use, or sale is prohibited under any applicable domestic or foreign laws or regulations.
6. Renesas Electronics has used reasonable care in preparing the information included in this document, but Renesas Electronics does not warrant that such information is error free. Renesas Electronics assumes no liability whatsoever for any damages incurred by you resulting from errors in or omissions from the information included herein.
7. Renesas Electronics products are classified according to the following three quality grades: “Standard”, “High Quality”, and “Specific”. The recommended applications for each Renesas Electronics product depends on the product’s quality grade, as indicated below. You must check the quality grade of each Renesas Electronics product before using it in a particular application. You may not use any Renesas Electronics product for any application categorized as “Specific” without the prior written consent of Renesas Electronics. Further, you may not use any Renesas Electronics product for any application for which it is not intended without the prior written consent of Renesas Electronics. Renesas Electronics shall not be in any way liable for any damages or losses incurred by you or third parties arising from the use of any Renesas Electronics product for an application categorized as “Specific” or for which the product is not intended where you have failed to obtain the prior written consent of Renesas Electronics. The quality grade of each Renesas Electronics product is “Standard” unless otherwise expressly specified in a Renesas Electronics data sheets or data books, etc.
 - “Standard”: Computers; office equipment; communications equipment; test and measurement equipment; audio and visual equipment; home electronic appliances; machine tools; personal electronic equipment; and industrial robots.
 - “High Quality”: Transportation equipment (automobiles, trains, ships, etc.); traffic control systems; anti-disaster systems; anti-crime systems; safety equipment; and medical equipment not specifically designed for life support.
 - “Specific”: Aircraft; aerospace equipment; submersible repeaters; nuclear reactor control systems; medical equipment or systems for life support (e.g. artificial life support devices or systems), surgical implantations, or healthcare intervention (e.g. excision, etc.), and any other applications or purposes that pose a direct threat to human life.
8. You should use the Renesas Electronics products described in this document within the range specified by Renesas Electronics, especially with respect to the maximum rating, operating supply voltage range, movement power voltage range, heat radiation characteristics, installation and other product characteristics. Renesas Electronics shall have no liability for malfunctions or damages arising out of the use of Renesas Electronics products beyond such specified ranges.
9. Although Renesas Electronics endeavors to improve the quality and reliability of its products, semiconductor products have specific characteristics such as the occurrence of failure at a certain rate and malfunctions under certain use conditions. Further, Renesas Electronics products are not subject to radiation resistance design. Please be sure to implement safety measures to guard them against the possibility of physical injury, and injury or damage caused by fire in the event of the failure of a Renesas Electronics product, such as safety design for hardware and software including but not limited to redundancy, fire control and malfunction prevention, appropriate treatment for aging degradation or any other appropriate measures. Because the evaluation of microcomputer software alone is very difficult, please evaluate the safety of the final products or system manufactured by you.
10. Please contact a Renesas Electronics sales office for details as to environmental matters such as the environmental compatibility of each Renesas Electronics product. Please use Renesas Electronics products in compliance with all applicable laws and regulations that regulate the inclusion or use of controlled substances, including without limitation, the EU RoHS Directive. Renesas Electronics assumes no liability for damages or losses occurring as a result of your noncompliance with applicable laws and regulations.
11. This document may not be reproduced or duplicated, in any form, in whole or in part, without prior written consent of Renesas Electronics.
12. Please contact a Renesas Electronics sales office if you have any questions regarding the information contained in this document or Renesas Electronics products, or if you have any other inquiries.

(Note 1) “Renesas Electronics” as used in this document means Renesas Electronics Corporation and also includes its majority-owned subsidiaries.

(Note 2) “Renesas Electronics product(s)” means any product developed or manufactured by or for Renesas Electronics.

Phase-out/Discontinued

μPD4990A

**SERIAL I/O CALENDAR & CLOCK
CMOS LSI**

The μPD4990A is a CMOS LSI developed to input/output calendar & clock data serially to/from the micro computer. The crystal frequency is 32.768 kHz and the data items included are time, minute, second, year, month, day, and week.

FEATURES

- Built-in counters for time (hour, minute, and second) and date (year, month, day, and week)
- Leap years are adjusted automatically.
- Data is represented in BCD notation (except months in hexadecimal notation) and input/output serially.
- Commands can be set by inputting serial data.
- Selective timing pulses (TPs) are 64 Hz, 256 Hz, 2 048 Hz, and 4 096 Hz and selective output intervals are 1, 10, 30, and 60 seconds.

ORDERING INFORMATION

PART No.	PACKAGE
μPD4990AC	14-pin plastic DIP (300 mil)
μPD4990AG	16-pin plastic SOP (300 mil)

CONNECTION DIAGRAM (Top View)

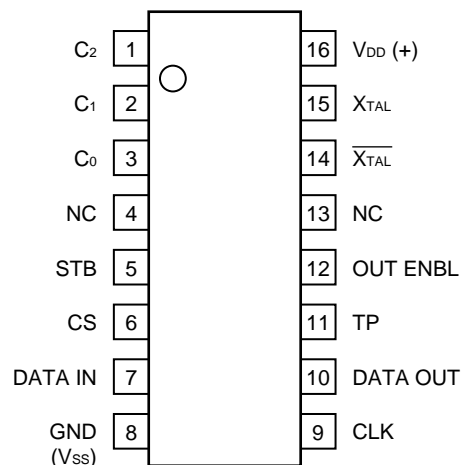
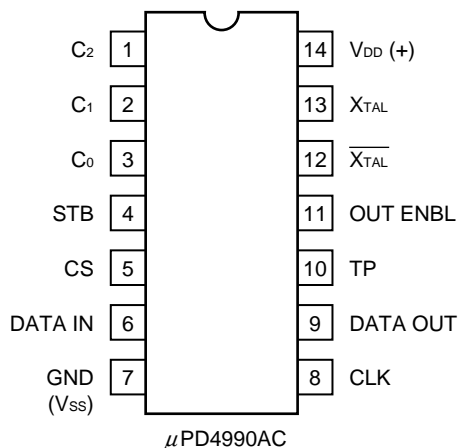

NC: NO CONNECTION

ABSOLUTE MAXIMUM RATINGS

Supply Voltage	$V_{DD} - V_{SS}$	-0.5 to 7.0	V
Input Voltage	V_{IN}	$V_{SS} - 0.3$ to $V_{DD} + 0.3$	V
Operating Temperature Range	T_{opt}	-40 to +85	°C
Storage Temperature Range	T_{stg}	-65 to +125	°C
Output Terminal Voltage	V_{OUT}	-0.5 to 7.0	V

ELECTRICAL CHARACTERISTICS (f = 32.768 kHz, C_G = C_D = 20 pF, C_I = 20 kΩ, T_a = 25 °C)

CHARACTERISTIC	SYMBOL	MIN.	TYP.	MAX.	UNIT	TEST CONDITIONS
Operating Voltage	$V_{DD} - V_{SS}$	2.00		5.50	V	
Current Consumption	I_{DD}		8	20	μ A	$V_{DD} - V_{SS} = 3.60$ V
				100	μ A	$V_{DD} - V_{SS} = 5.50$ V
Low Level Output Voltage	V_{OL}			0.4*	V	$V_{DD} - V_{SS} = 2.0$ to 5.5 V $I_{OL} = 500$ μ A
CLK Input Frequency	f_{CLK}	DC		500	kHz	$V_{DD} - V_{SS} = 2.0$ V, Duty 50 %
Input Leakage Current	I_{IN}			± 1	μ A	$V_{DD} - V_{SS} = 5.50$ V
High Level Input Voltage	V_{IH}	0.7 V_{DD}		V_{DD}	V	
Low Level Input Voltage	V_{IL}	V_{SS}		0.3 V_{DD}	V	

* TP and DATA OUT are N-channel open drain output.

A.C. ELECTRICAL CHARACTERISTICS (f = 32.768 kHz, V_{DD} – V_{SS} = 2.0 V, T_a = 25 °C)

CHARACTERISTIC	SYMBOL	MIN.	TYP.	MAX.	UNIT	TEST CONDITIONS
C _{0 to 2} , CS – STB Set-up Time	t_{SU}	1			μ S	
STB Pulse Width	t_{STB}	1			μ S	
C _{0 to 2} , CS – STB Hold Time	t_{HLD}	1			μ S	
STB LATCH Delay Time	t_{d1}			1**	μ S	except Time Read mode
CLK-DATA OUT Delay time	$t_{d(c-o)}$			1	μ S	$R_L = 33$ kΩ, $C_L = 15$ pF
DATA IN Set-up Time	t_{DSU}	1			μ S	
DATA IN Hold Time	t_{DHLD}	1			μ S	

** **Note:** When a function mode is Time Read mode (other than Test mode), STB LATCH delay time is 20 μ S MAX. (t_{d2}).

BLOCK DIAGRAM

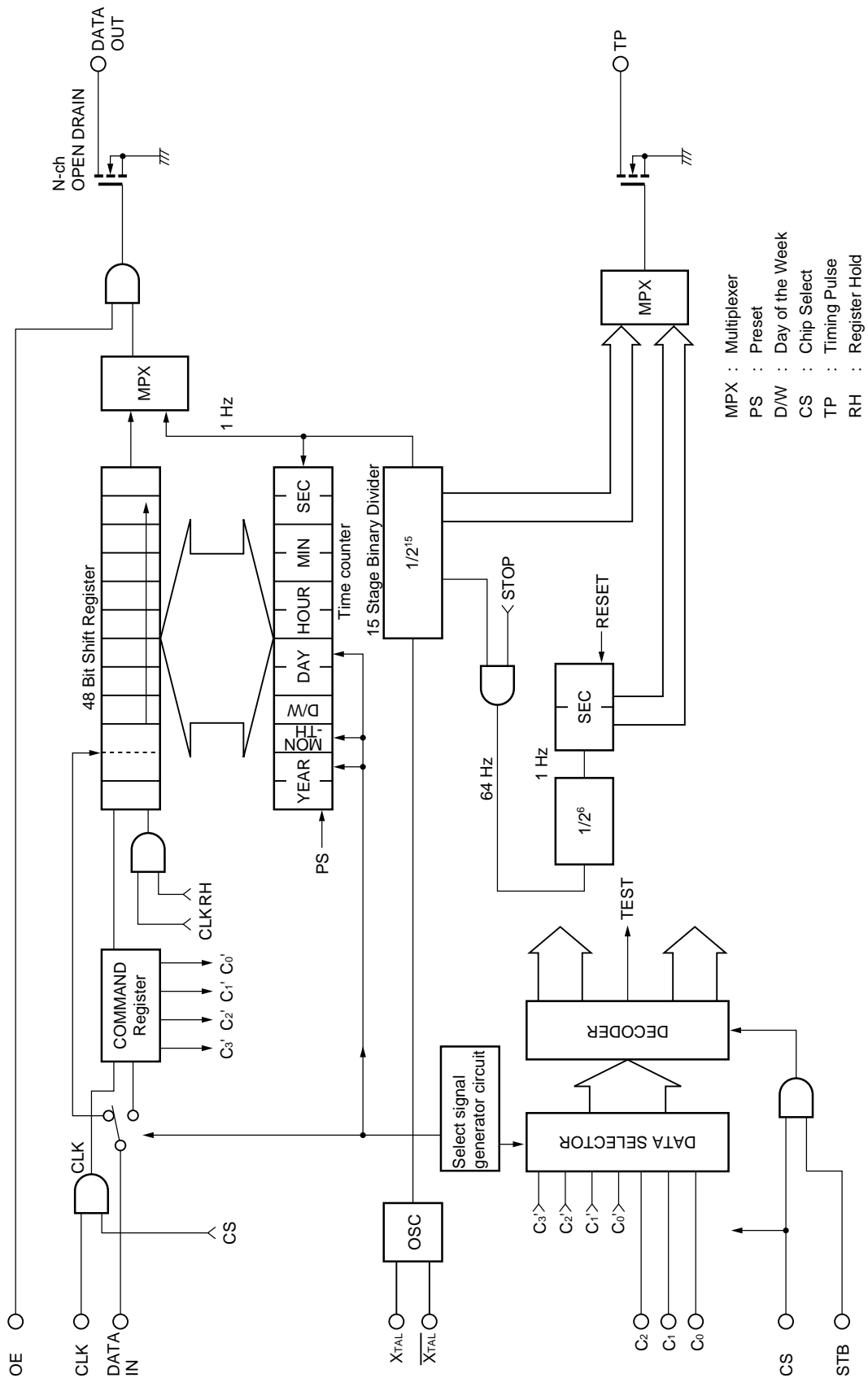

FUNCTION SPECIFICATIONS

- Crystal frequency (X tal osc.)
 - 32.768 kHz

- Data
 - Data types are: second, minute, day, week, month, and year.
 - Leap years, 31-day months, and months with 30 or less days are adjusted automatically.
 - A 24-hour system is used and last two digits of Gregorian year are indicated.
 - It is assumed that leap years are expressed by multiples of 4.

- Data format
 - Data is represented in BCD notation. Only months are represented in hexadecimal notation.

- Data input-output and Clock
 - Data is input/output synchronously with reference to the external clocks input from the CLK pin using the serial input/output system. (See Fig. 1.)

- Timing pulse output
 - Three frequencies, 64 Hz, 256 Hz, and 2 048 Hz, can be set with C₀, C₁ and C₂ pins.
 - Using serial data input command, selective timing pulses (TPs) are 64 Hz, 256 Hz, 2 048 Hz, and 4 096 Hz and selective output intervals are 1, 10, 30, and 60 seconds.

- Function mode selection
 - A function mode can be selected by the inputs from C₀, C₁, and C₂. Also a function mode can be selected through serial data input. (C₀ = C₁ = C₂ = V_{DD})
 - Each command is latched with STB (strobe).

- Chip select
 - Connecting the CS pin to the ground level inhibits CLK and STB inputs.

- Data output inhibition
 - Connecting the OUT ENBL pin to the ground level sets the DATA OUT pin at high impedance.

Figure 1.

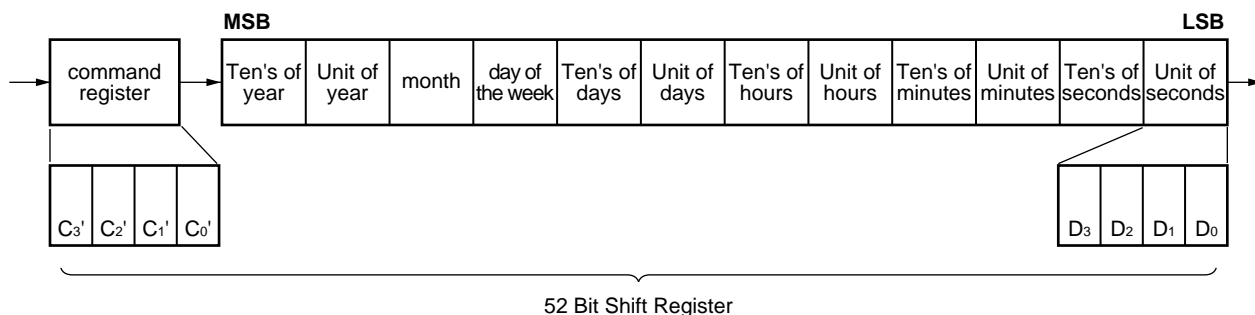

* DATA of 52 Bit Shift Register appears on DATA OUT terminal from LSB of second.

TERMINALS

- Input terminals
 - DATA IN Data input of 40-/52-bit shift register
 - CLK Shift clock input of 40-/52-bit shift register
 - C₀, C₁, C₂ Command input (3 bit)
 - STB Strobe input
 - CS Chip select input (Prohibits CLK & STB)
 - OUT ENBL Output control input (Makes the DATA OUT high impedance by inputting low level).

- Output terminals (N-channel Open Drain)
 - DATA OUT Data output of 40-/52-bit shift register
 - TP Timing pulse output

- Oscillation terminals
 - X_{TAL} Oscillation inverter input (OSC IN)
 - $\overline{X_{TAL}}$ Oscillation inverter output (OSC OUT)

- Power supply terminals
 - V_{DD} Plus power supply
 - GND (V_{SS}) Common line

COMMAND SPECIFICATIONS

- o Commands input from C₀, C₁, and C₂ pins (1 ...H, 0 ...L)
 Shift register 40 bit (The year function is ineffective.)
 (Operates as the existing μPD1990AC in other than test mode)

C ₂	C ₁	C ₀	FUNCTION	
0	0	0	Register Hold	DATA OUT = 1 Hz
0	0	1	Register Shift	DATA OUT = [LSB] = 0 or 1
0	1	0	Time Set & Counter Hold	DATA OUT = [LSB] = 0 or 1
0	1	1	Time Read	DATA OUT = 1 Hz
1	0	0	TP = 64 Hz	
1	0	1	TP = 256 Hz	
1	1	0	TP = 2 048 Hz	
1	1	1	Serial command transfer mode	

* The test mode is cancelled by [C₂, C₁, C₀] = [0, 0, 0] to [1, 1, 0].

- o Serial data commands
 Set [C₂, C₁, C₀] = [1, 1, 1] at all time.
 Shift register 52 bit (The year function is effective.)

C ₃ '	C ₂ '	C ₁ '	C ₀ '	FUNCTION	
0	0	0	0	Register Hold	DATA OUT = 1 Hz
0	0	0	1	Register Shift	DATA OUT = [LSB] = 0 or 1
0	0	1	0	Time Set & Counter Hold	DATA OUT = [LSB] = 0 or 1
0	0	1	1	Time Read	DATA OUT = 1 Hz
0	1	0	0	TP = 64 Hz	
0	1	0	1	TP = 256 Hz	
0	1	1	0	TP = 2 048 Hz	
0	1	1	1	TP = 4 096 Hz	
1	0	0	0	TP = 1 s interval set (counter reset & start)	
1	0	0	1	TP = 10 s interval set (counter reset & start)	
1	0	1	0	TP = 30 s interval set (counter reset & start)	
1	0	1	1	TP = 60 s interval set (counter reset & start)	
1	1	0	0	Interval Output Flag Reset	
1	1	0	1	Interval Timer Clock Run	
1	1	1	0	Interval Timer Clock Stop	
1	1	1	1	TEST MODE SET	

When serial data commands are used, C₀, C₁, and C₂ pins should be connected V_{DD} pin.

- Command input
 - (1) 3-bit binary code input: C₂, C₁, C₀
 - (2) 4-bit serial transfer command input: C₃['], C₂['], C₁['], C₀[']

- Number of commands

	C ₂ , C ₁ , C ₀	C ₃ ['] , C ₂ ['] , C ₁ ['] , C ₀ [']
Register control	4	4
TP select	3	8
TP control	0	3
Test mode set	1	1

- Commands (C₃['], C₂['], C₁['], C₀['] commands are made effective only when [C₂, C₁, C₀] = [1, 1, 1].)
 - (1) Register control [C₂, C₁, C₀] / [C₃['], C₂['], C₁['], C₀[']]
 - **Register Hold Mode** [0, 0, 0] / [0, 0, 0, 0]
 [C₂, C₁, C₀]
 The 40-bit shift register is held. The year function is ineffective.
 [C₃['], C₂['], C₁['], C₀[']]
 The 48-bit shift register is held.
 The command register is not held.
 * The DATA OUT output frequency is 1 Hz.
 - **Register Shift Mode** [0, 0, 1] / [0, 0, 0, 1]
 [C₂, C₁, C₀]
 The 40-bit shift register data can be shifted. The year function is ineffective.
 [C₃['], C₂['], C₁['], C₀[']]
 Data in 52-bit shift registers (including command registers) can be shifted. For command register, data can be always shifted using the serial command transfer mode.
 * The DATA OUT output is LSB data from the shift register.
 - **Time Set and Counter Hold Mode** [0, 1, 0] / [0, 0, 1, 0]
 [C₂, C₁, C₀]
 Data is transferred from the 40-bit shift register to the time counter. The year function is ineffective.
 [C₃['], C₂['], C₁['], C₀[']]
 Data is transferred from the 48-bit shift register to the time counter.
 * This command is used to reset the last 10-15 of 15 Stage Binary Divider and holds the time counter.
 15 Stage Binary Divider resetting and time counter release are executed by the following:
 [C₂, C₁, C₀] = [0, 0, 0] [0, 0, 1] [0, 1, 1] [C₃['], C₂['], C₁['], C₀[']] = [0, 0, 0, 0] [0, 0, 0, 1] [0, 0, 1, 1]
 The time setting accuracy is ±15.625 ms.
 The DATA OUT pin outputs LSB data (0 or 1) from the shift register.
 After this command is executed, the 40-/48-bit shift register is held and data cannot be shifted.
 - **Time Read Mode** [0, 1, 1] / [0, 0, 1, 1]
 [C₂, C₁, C₀]
 Data is transferred from the time-counter to the 40-bit shift register. The year function is ineffective.
 [C₃['], C₂['], C₁['], C₀[']]
 Data is transferred from the time counter to the 48-bit shift register.
 * The DATA OUT pin output is a 1 Hz frequency.
 After this command is executed, the 40-/48-bit shift register is held and data cannot be shifted.

(2) TP selection and control [C₂, C₁, C₀] / [C₃', C₂', C₁', C₀']

- **TP = 64 Hz** Set Mode [1, 0, 0] / [0, 1, 0, 0]
64 Hz (50 % duty) is output to the TP pin.
[C₂, C₁, C₀]: The year function is ineffective and the interval timer stops.
 - **TP = 256 Hz** Set Mode [1, 0, 1] / [0, 1, 0, 1]
256 Hz (50 % duty) is output to the TP pin.
[C₂, C₁, C₀]: The year function is ineffective and the interval timer stops.
 - **TP = 2 048 Hz** Set Mode [1, 1, 0] / [0, 1, 1, 0]
2 048 Hz (50 % duty) is output to the TP pin.
[C₂, C₁, C₀]: The year function is ineffective and the interval timer stops.
- Modes permitted only for serial commands [C₃', C₂', C₁', C₀']
- **TP = 4 098 Hz** Set Mode [0, 1, 1, 1]
4 098 Hz (50 % duty) is output to the TP pin. The interval timer stops.
 - **TP = 1-second** Interval Set Mode (counter reset & start) [1, 0, 0, 0]
A 1-second interval signal is output to the TP pin.
 - **TP = 10-second** Interval Set Mode (counter reset & start) [1, 0, 0, 1]
A 10-second interval signal is output to the TP pin.
 - **TP = 30-second** Interval Set Mode (counter reset & start) [1, 0, 1, 0]
A 30-second interval signal is output to the TP pin.
 - **TP = 60-second** Interval Set Mode (counter reset & start) [1, 0, 1, 1]
A 60-second interval signal is output to the TP pin.
 - **Interval Output Flag Reset** [1, 1, 0, 0]
The interval signal output to the TP pin is reset.
The interval timer counter continue the operation.
 - **Interval Timer Clock Run** [1, 1, 0, 1]
The timer for outputting interval signals is reset then started.
 - **Interval Timer Clock Stop** [1, 1, 1, 0]
The timer for outputting interval signals stops.
The output status does not change.

(3) Serial command transfer mode setting

Set [C₂, C₁, C₀] = [1, 1, 1]

(4) Test mode setting

Set [C₂, C₁, C₀] = [1, 1, 1] [C₃', C₂', C₁', C₀'] = [1, 1, 1, 1]

- 3-bit parallel command setting mode [C₂, C₁, C₀]
The year function is ineffective when commands are input through C₂, C₁, and C₀ pins.
Generally, February involves 28 days. The 29th day can be set optionally. The next day of the February 29th can be set the March 1st automatically. The interval timer is in the halt state.
* The test mode is cancelled by [C₂, C₁, C₀] = [0, 0, 0] to [1, 1, 0].
- Serial command transfer mode [C₃', C₂', C₁', C₀']
If a strobe signal is input with C₂, C₁, and C₀ pins set at the V_{DD} level ([1, 1, 1]), the contents of the serial command register ([C₃', C₂', C₁', C₀']) are received as a command; the year function is effective.
* The test mode is cancelled by [C₃', C₂', C₁', C₀']
= [0, 0, 0]
= [0, 1, 0, 0] to [1, 1, 1, 0]

In this mode, the serial command register is not held with the Register Hold command. Accordingly, the serial command can be executed irrespective of the mode if the CS pin is active.

The year function is effective in the serial command transfer mode.

o Interval output function

An interrupt signal can be output by selecting an output from TP.

Interrupt signals are output repeatedly at specified intervals until their output is suppressed by a command.

Only output flags can be reset to operate the timer continuously.

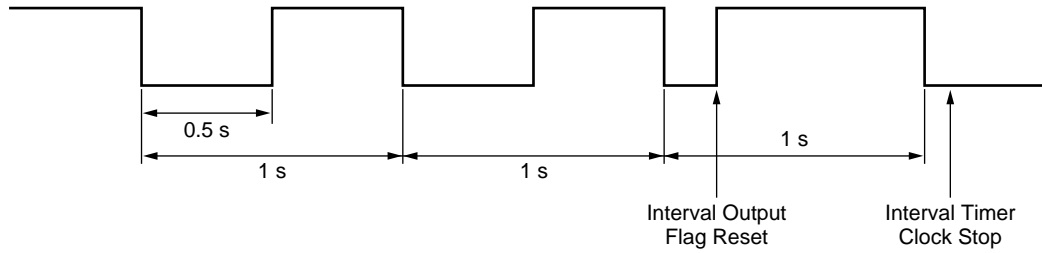

Interval of 1 second

The interval signal waveform is rectangular (50 % duty) if not reset.

The interval timer is independent of the Timer Counter, so it is not affected by the resetting of the current time timer.

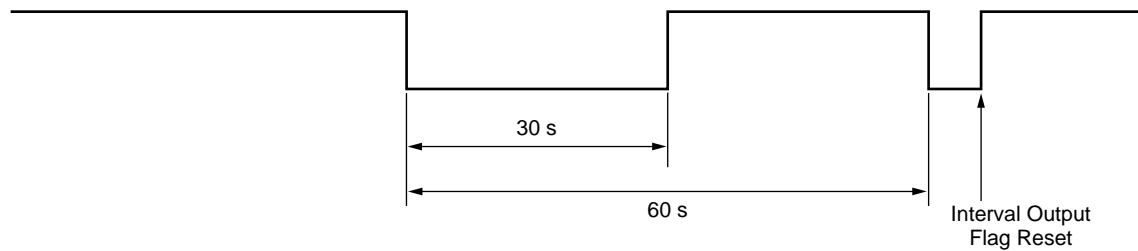

The interval timer accuracy is ±15.625 ms.

* The interval timer counter is reset by [1, 0, 0, 0] through [1, 0, 1, 1].

o Test mode

In the test mode, data is output to the DATA OUT pin regardless of whether data has been input to OUT ENBL.

There are two different test modes depending on the OUT ENBL data.

(1) Test mode 1 (OUT ENBL = 0)

8 192 Hz signals are set parallel in the counters for year, month, week, day, time, minute, and second. There is no carry from these counters.

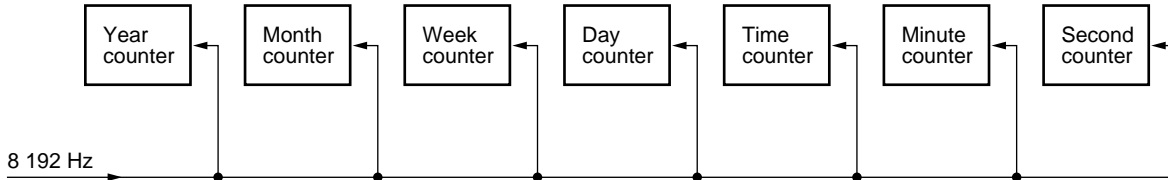

(2) Test mode 2 (OUT ENBL = 1)

A 8 192 Hz signal is input to the second counter instead of the 1 Hz signal. There is carry from counters.

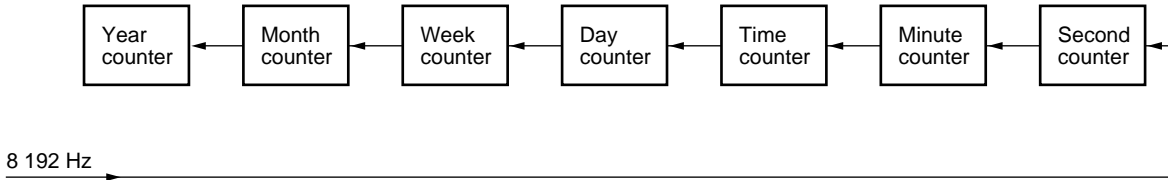

Outputs from DATA OUT and TP OUT pins in different function modes are listed below.

MODE	DATA OUT	TP	Others
REGISTER HOLD	1 Hz	64 Hz	By this command, TEST MODE is released.
REGISTER SHIFT	LSB of shift register	32 Hz	Test mode
TIME SET	LSB of shift register	L Level	
TIME READ	1 Hz	32 Hz	

When the REGISTER HOLD command cancels the test mode, 64 Hz is output to the TP pin.

TIMING DIAGRAM FOR SETTING COMMANDS (C₀', C₁', C₂', C₃')

Figure 2.

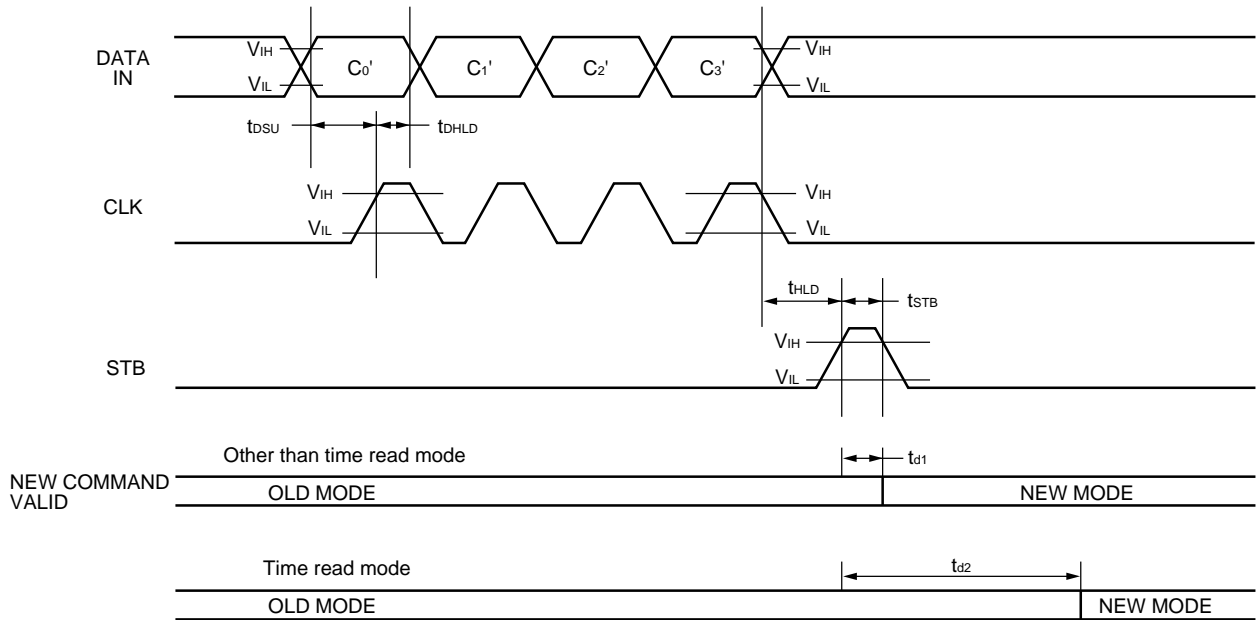

V_{DD} - V_{SS} = 2.0 V

t_{DSU} = 1 μs MIN.

t_{DHLd} = 1 μs MIN.

t_{HLD} = 1 μs MIN.

t_{STB} = 1 μs MIN.

t_{d1} = 1 μs MAX. (Other than time read mode)

t_{d2} = 20 μs MAX. (Time read mode)

Note: Command (C₂, C₁, C₀) is set to (1, 1, 1)

CS = "H"

A mode is latched by STB and held until another mode in the same group is set.

TIMING DIAGRAM FOR SETTING COMMANDS (C₀, C₁, C₂)

Figure 3.

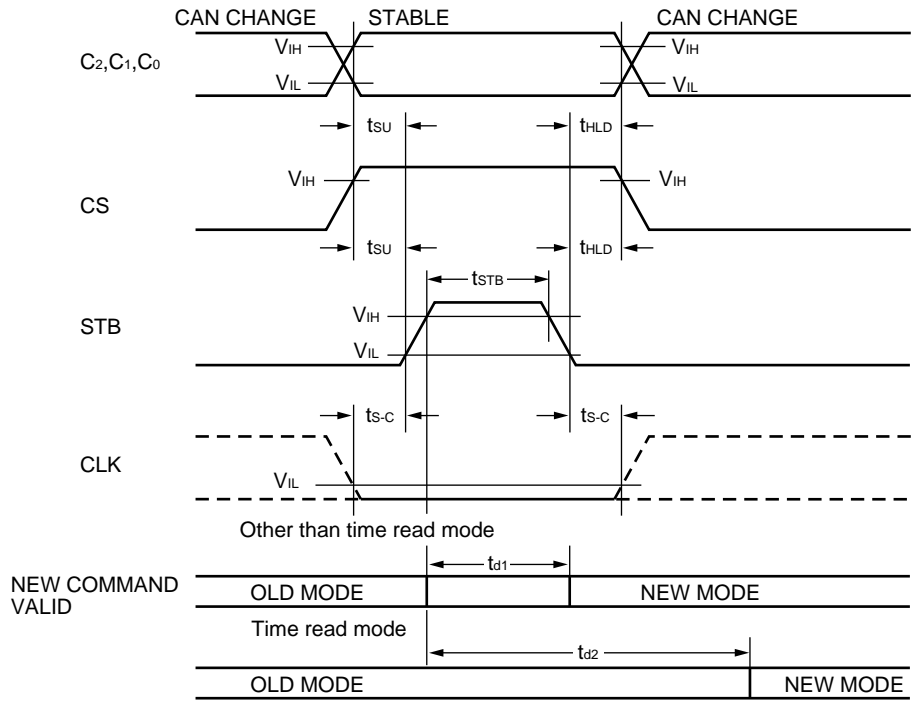

$V_{DD} - V_{SS} = 2.0 V$

- $t_{su} = 1 \mu s \text{ MIN.}$
- $t_{hld} = 1 \mu s \text{ MIN.}$
- $t_{stb} = 1 \mu s \text{ MIN.}$
- $t_{d1} = 1 \mu s \text{ MAX. (Other than time read mode)}$
- $t_{d2} = 20 \mu s \text{ MAX. (Time read mode)}$
- $t_{s-c} = 1 \mu s \text{ MIN.}$

Note: A mode is latched by STB and held until another mode in the same group is set.

DATA INPUT/OUTPUT TIMING DIAGRAM

Figure 4.

Command (C₂, C₁, C₀) is set to (1, 1, 1).
 Command (C₃', C₂', C₀') is set to [0001] (Register Shift Mode).
 CS = "H"

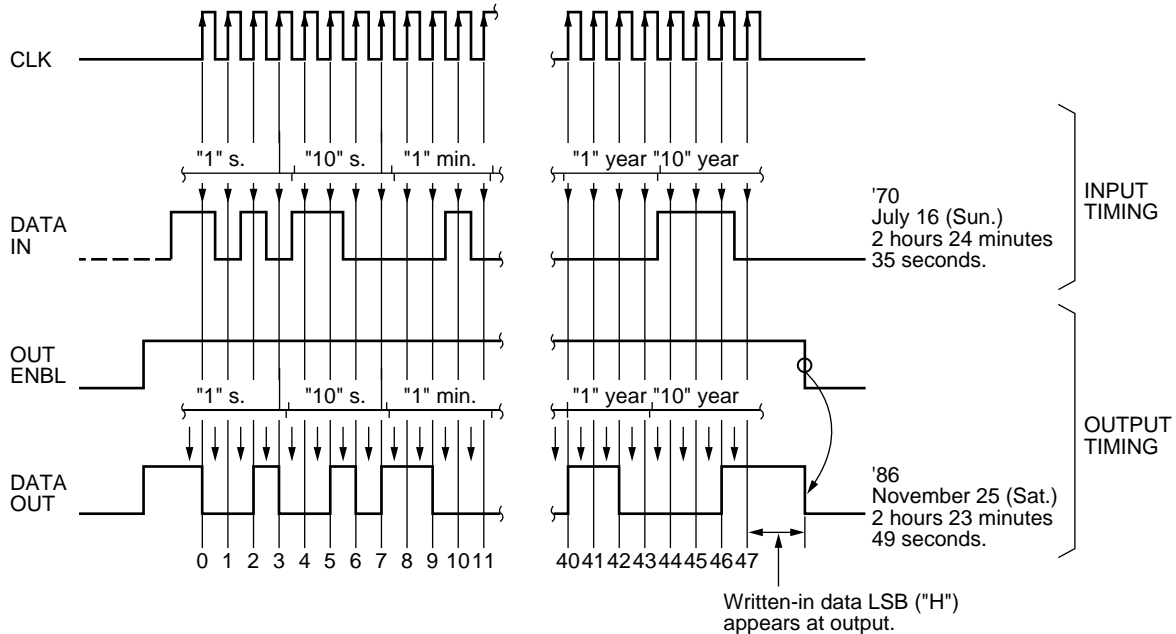

Note: Reading-in timing of CPU (Trailing edge of CLK).

TIMING DIAGRAM OF DATA INPUT AND OUTPUT

Figure 5.

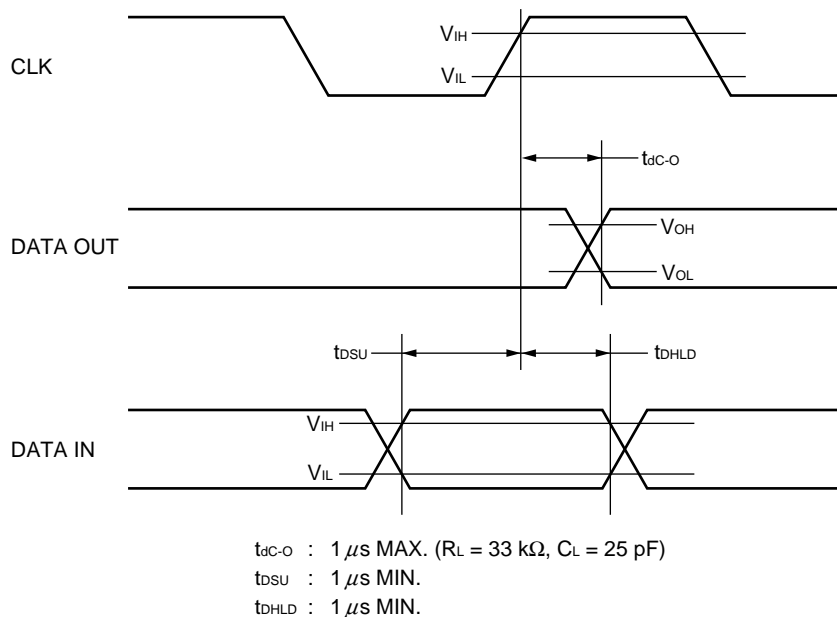

POWER SUPPLY CIRCUIT

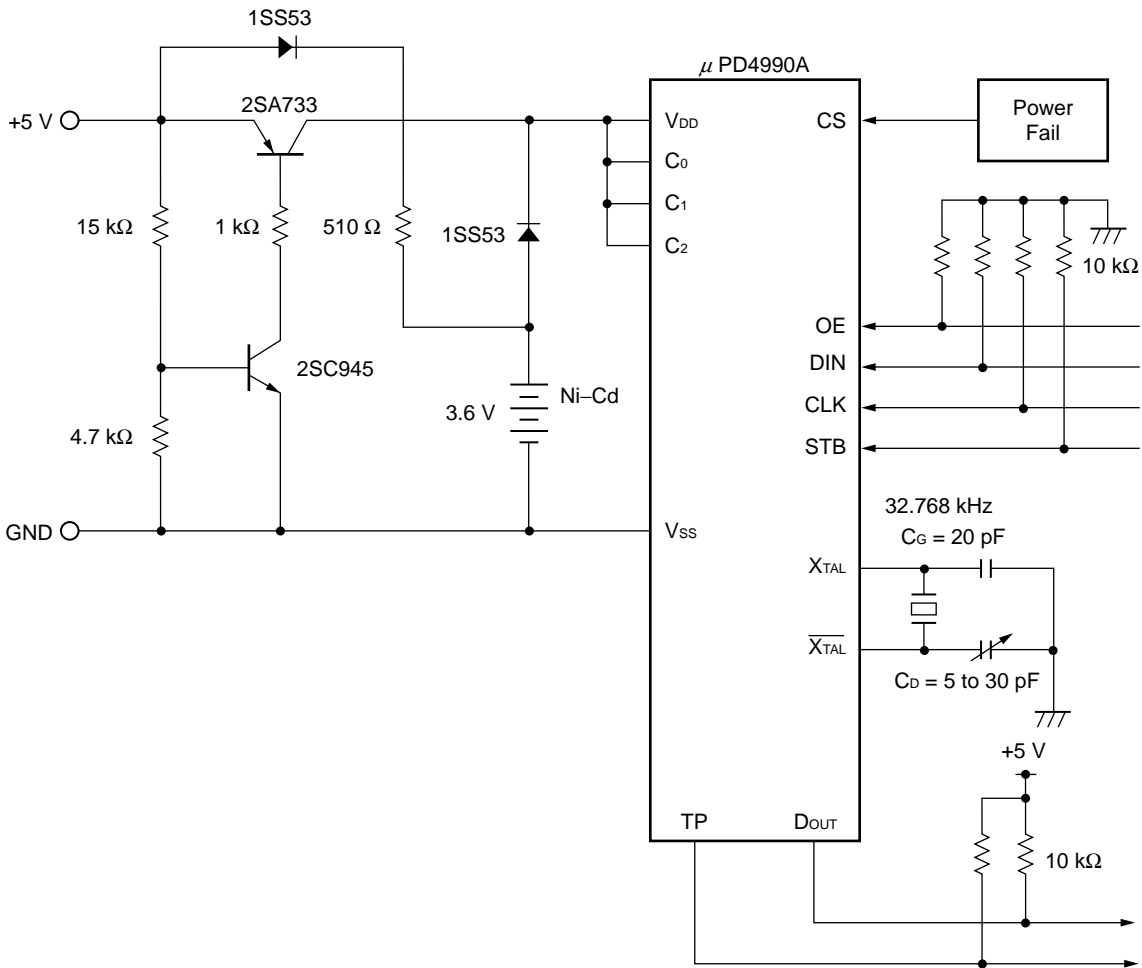

APPLICATION

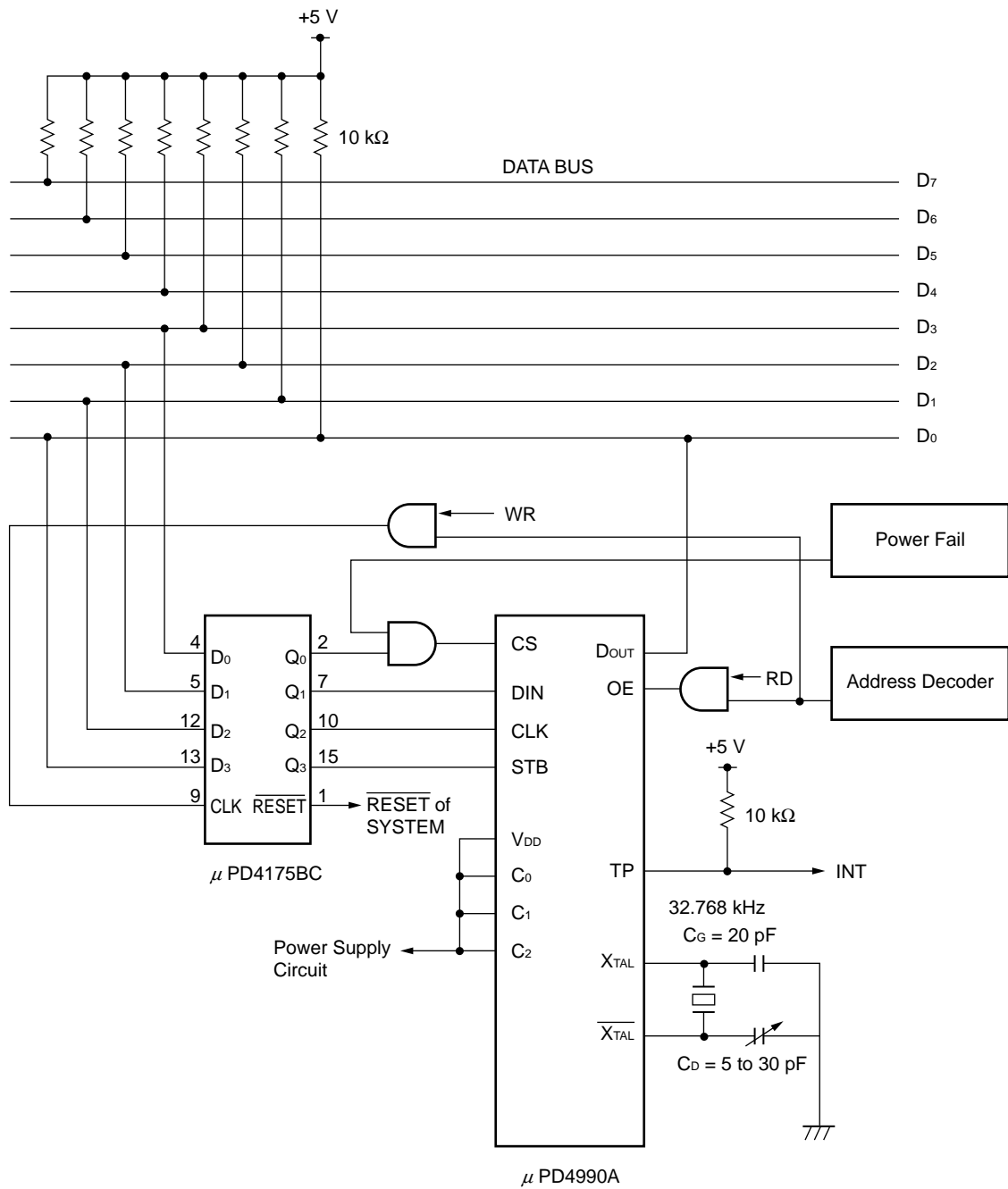

14PIN PLASTIC DIP (300 mil)

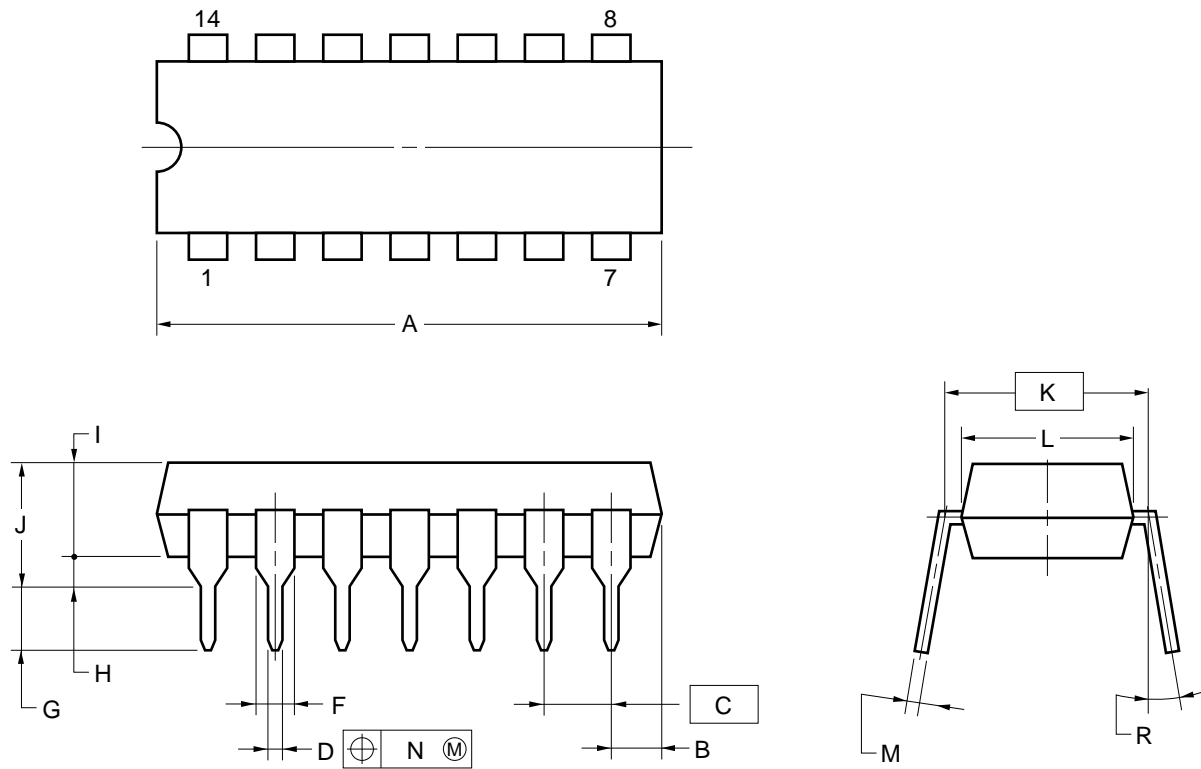

NOTES

- 1) Each lead centerline is located within 0.25 mm (0.01 inch) of its true position (T.P.) at maximum material condition.
- 2) Item "K" to center of leads when formed parallel.

ITEM	MILLIMETERS	INCHES
A	20.32 MAX.	0.800 MAX.
B	2.54 MAX.	0.100 MAX.
C	2.54 (T.P.)	0.100 (T.P.)
D	0.50±0.10	0.020 ^{+0.004} _{-0.005}
F	1.2 MIN.	0.047 MIN.
G	3.5±0.3	0.138±0.012
H	0.51 MIN.	0.020 MIN.
I	4.31 MAX.	0.170 MAX.
J	5.08 MAX.	0.200 MAX.
K	7.62 (T.P.)	0.300 (T.P.)
L	6.4	0.252
M	0.25 ^{+0.10} _{-0.05}	0.010 ^{+0.004} _{-0.003}
N	0.25	0.01
R	0~15°	0~15°

P14C-100-300A,C-1

16 PIN PLASTIC SOP (300 mil)

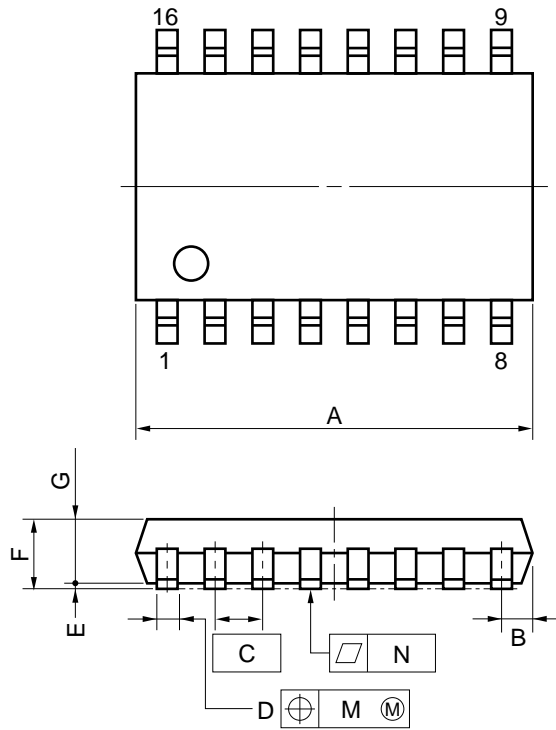

detail of lead end

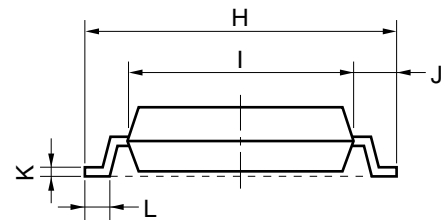
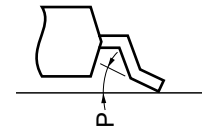

NOTE

Each lead centerline is located within 0.12 mm (0.005 inch) of its true position (T.P.) at maximum material condition.

ITEM	MILLIMETERS	INCHES
A	10.46 MAX.	0.412 MAX.
B	0.78 MAX.	0.031 MAX.
C	1.27 (T.P.)	0.050 (T.P.)
D	0.40 ^{+0.10} _{-0.05}	0.016 ^{+0.004} _{-0.003}
E	0.1±0.1	0.004±0.004
F	1.8 MAX.	0.071 MAX.
G	1.55	0.061
H	7.7±0.3	0.303±0.012
I	5.6	0.220
J	1.1	0.043
K	0.20 ^{+0.10} _{-0.05}	0.008 ^{+0.004} _{-0.002}
L	0.6±0.2	0.024 ^{+0.008} _{-0.009}
M	0.12	0.005
N	0.10	0.004
P	3° ^{+7°} _{-3°}	3° ^{+7°} _{-3°}

P16GM-50-300B-4

[MEMO]

[MEMO]

No part of this document may be copied or reproduced in any form or by any means without the prior written consent of NEC Corporation. NEC Corporation assumes no responsibility for any errors which may appear in this document.

NEC Corporation does not assume any liability for infringement of patents, copyrights or other intellectual property rights of third parties by or arising from use of a device described herein or any other liability arising from use of such device. No license, either express, implied or otherwise, is granted under any patents, copyrights or other intellectual property rights of NEC Corporation or others.

While NEC Corporation has been making continuous effort to enhance the reliability of its semiconductor devices, the possibility of defects cannot be eliminated entirely. To minimize risks of damage or injury to persons or property arising from a defect in an NEC semiconductor device, customers must incorporate sufficient safety measures in its design, such as redundancy, fire-containment, and anti-failure features.

NEC devices are classified into the following three quality grades:

"Standard", "Special", and "Specific". The Specific quality grade applies only to devices developed based on a customer designated "quality assurance program" for a specific application. The recommended applications of a device depend on its quality grade, as indicated below. Customers must check the quality grade of each device before using it in a particular application.

Standard: Computers, office equipment, communications equipment, test and measurement equipment, audio and visual equipment, home electronic appliances, machine tools, personal electronic equipment and industrial robots

Special: Transportation equipment (automobiles, trains, ships, etc.), traffic control systems, anti-disaster systems, anti-crime systems, safety equipment and medical equipment (not specifically designed for life support)

Specific: Aircrafts, aerospace equipment, submersible repeaters, nuclear reactor control systems, life support systems or medical equipment for life support, etc.

The quality grade of NEC devices is "Standard" unless otherwise specified in NEC's Data Sheets or Data Books. If customers intend to use NEC devices for applications other than those specified for Standard quality grade, they should contact an NEC sales representative in advance.

Anti-radioactive design is not implemented in this product.