

True low-power platform (58.3 μ A/MHz, and 0.64 μ A for operation with only RTC2 and LVD) for the general-purpose applications, with 1.6-V to 3.6-V operation, 8- to 32-Kbyte code flash memory, and 33 DMIPS at 24 MHz

1. OUTLINE

1.1 Features

Ultra-low power consumption technology

- VDD = 1.6 V to 3.6 V
- HALT mode
- STOP mode
- SNOOZE mode

RL78 CPU core

- CISC architecture with 3-stage pipeline
- Minimum instruction execution time: Can be changed from high speed (0.04167 μ s: @ 24 MHz operation with high-speed on-chip oscillator) to ultra-low speed (66.6 μ s: @ 15 kHz operation with low-speed on-chip oscillator clock)
- Multiply/divide/multiply & accumulate instructions are supported.
- Address space: 1 MB
- General-purpose registers: (8-bit register \times 8) \times 4 banks
- On-chip RAM: 0.7 to 3 KB

Code flash memory

- Code flash memory: 8 to 32 KB
- Block size: 1 KB
- Prohibition of block erase and rewriting (security function)
- On-chip debug function
- Self-programming (with boot swap function/flash shield window function)

Data flash memory

- Data flash memory: 2 KB
- Back ground operation (BGO): Instructions can be executed from the program memory while rewriting the data flash memory.
- Number of rewrites: 1,000,000 times (TYP.)
- Voltage of rewrites: VDD = 1.8 to 3.6 V

High-speed on-chip oscillator

- Select from 24 MHz, 16 MHz, 12 MHz, 8 MHz, 6 MHz, 4 MHz, 3 MHz, 2 MHz, and 1 MHz
- High accuracy: \pm 1.0% (VDD = 1.8 to 3.6 V, TA = -20 to +85°C)

Middle-speed on-chip oscillator

- Selectable from 4 MHz, 2 MHz, and 1 MHz.

Operating ambient temperature

- TA = -40 to +105°C (G: Industrial applications)

Power management and reset function

- On-chip power-on-reset (POR) circuit
- On-chip voltage detector (LVD) (Select interrupt and reset from 12 levels)

Data transfer controller (DTC)

- Transfer modes: Normal transfer mode, repeat transfer mode, block transfer mode
- Activation sources: Activated by interrupt sources.
- Chain transfer function

Event link controller (ELC)

- Event signals of 20 types can be linked to the specified peripheral function.

Serial interfaces

- Simplified SPI (CSI^{Note}): 1 or 2 channels
- UART: 1 channel
- I²C/simplified I²C: 1 or 2 channels

Timers

- 16-bit timer: 4 channels
- 12-bit interval timer: 1 channel
- 8-bit interval timer: 4 channels
- Real-time clock: 1 channel (calendar for 99 years, alarm function, and clock correction function)
- Watchdog timer: 1 channel

A/D converter

- 8/12-bit resolution A/D converter (VDD = 1.6 to 3.6 V)
- Analog input: 6 to 17 channels
- Internal reference voltage (1.45 V) and temperature sensor

Comparator

- 2 channels
- Operating modes: Comparator high-speed mode, comparator low-speed mode, window mode

Operational amplifier

- 4 channels

I/O ports

- I/O port: 14 to 42 (N-ch open drain I/O [withstand voltage of 6 V]: 4, N-ch open drain I/O [VDD withstand voltage]: 3 to 7)
- Can be set to N-ch open drain, TTL input buffer, and on-chip pull-up resistor
- Different potential interface: Can connect to a 1.8/2.5 V device
- On-chip key interrupt function
- On-chip clock output/buzzer output controller

Others

- On-chip BCD (binary-coded decimal) correction circuit
- On-chip data operation circuit

(Note and Remark are listed on the next page.)

Note Although the CSI function is generally called SPI, it is also called CSI in this product, so it is referred to as such in this manual.

Remark The functions mounted depend on the product. See **1.6 Outline of Functions**.

○ ROM, RAM capacities

Flash ROM	Data flash	RAM	RL78/I1D				
			20 pins	24 pins	30 pins	32 pins	48 pins
32 KB	2 KB	3 KB Note	—	—	R5F117AC	R5F117BC	R5F117GC
16 KB	2 KB	2 KB	R5F1176A	R5F1177A	R5F117AA	R5F117BA	R5F117GA
8 KB	2 KB	0.7 KB	R5F11768	R5F11778	R5F117A8	—	—

Note The flash library uses RAM in self-programming and rewriting of the data flash memory.
The target products and start address of the RAM areas used by the flash library are shown below.

R5F117xC (x = A, B, G): Start address FF300H

For the RAM areas used by the flash library, see **Self RAM list of Flash Self-Programming Library for RL78 Family (R20UT2944)**.

1.2 Ordering Information

<R>

Figure 1 - 1 Part Number, Memory Size, and Package of RL78/I1D

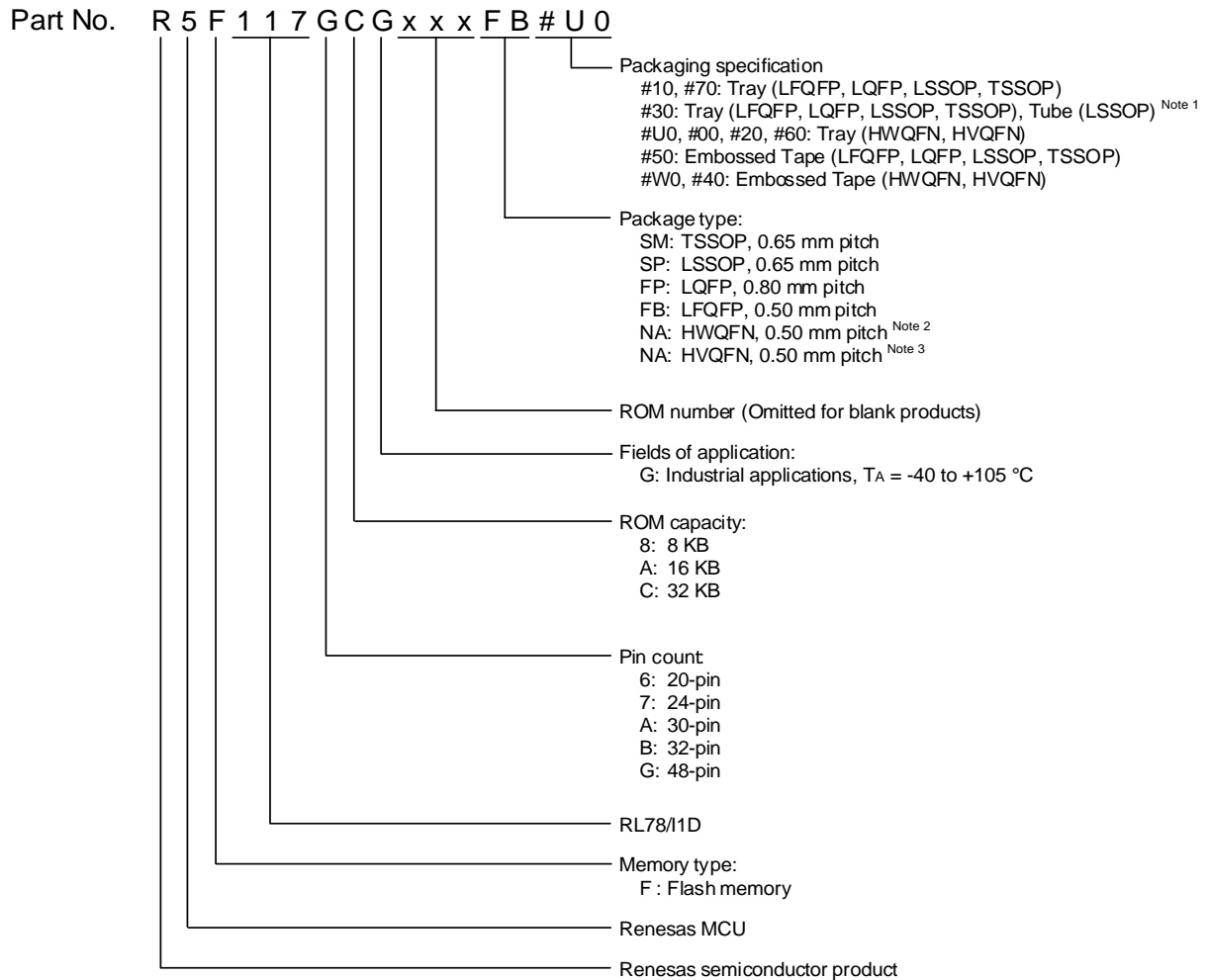

Note 1. The packaging specification is only "Tube" for products in the 20-pin LSSOP.

Note 2. 24-pin products

Note 3. 32-pin products

<R>

Pin count	Package	Ordering Part Number	RENESAS Code
20 pins	20-pin plastic LSSOP (4.4 × 6.5 mm, 0.65 mm pitch)	R5F11768GSP#30, R5F1176AGSP#30, R5F11768GSP#50, R5F1176AGSP#50	PLSP0020JB-A
	20-pin plastic TSSOP (4.4 × 6.5 mm, 0.65 mm pitch)	R5F11768GSM#10, R5F1176AGSM#10, R5F11768GSM#30, R5F1176AGSM#30, R5F11768GSM#50, R5F1176AGSM#50, R5F11768GSM#70, R5F1176AGSM#70	PTSP0020JI-A
24 pins	24-pin plastic HWQFN (4 × 4 mm, 0.5 mm pitch)	R5F11778GNA#U0, R5F1177AGNA#U0, R5F11778GNA#W0, R5F1177AGNA#W0	PWQN0024KE-A
		R5F11778GNA#00, R5F1177AGNA#00, R5F11778GNA#20, R5F1177AGNA#20, R5F11778GNA#40, R5F1177AGNA#40, R5F11778GNA#60, R5F1177AGNA#60	PWQN0024KF-A PWQN0024KH-A
30 pins	30-pin plastic LSSOP (7.62 mm (300), 0.65 mm pitch)	R5F117A8GSP#10, R5F117AAGSP#10, R5F117ACGSP#10, R5F117A8GSP#30, R5F117AAGSP#30, R5F117ACGSP#30, R5F117A8GSP#50, R5F117AAGSP#50, R5F117ACGSP#50, R5F117A8GSP#70, R5F117AAGSP#70, R5F117ACGSP#70	PLSP0030JB-B
32 pins	32-pin plastic HVQFN (5 × 5 mm, 0.5 mm pitch)	R5F117BAGNA#00, R5F117BCGNA#00, R5F117BAGNA#20, R5F117BCGNA#20, R5F117BAGNA#40, R5F117BCGNA#40, R5F117BAGNA#60, R5F117BCGNA#60	PVQN0032KE-A
	32-pin plastic LQFP (7 × 7 mm, 0.8 mm pitch)	R5F117BAGFP#10, R5F117BCGFP#10, R5F117BAGFP#30, R5F117BCGFP#30, R5F117BAGFP#50, R5F117BCGFP#50, R5F117BAGFP#70, R5F117BCGFP#70	PLQP0032GB-A
48 pins	48-pin plastic LFQFP (7 × 7 mm, 0.5 mm pitch)	R5F117GAGFB#10, R5F117GCGFB#10, R5F117GAGFB#30, R5F117GCGFB#30, R5F117GAGFB#50, R5F117GCGFB#50, R5F117GAGFB#70, R5F117GCGFB#70	PLQP0048KB-A

Caution The ordering part numbers represent the numbers at the time of publication. For the latest ordering part numbers, refer to the target product page of the Renesas Electronics website.

1.3 Pin Configuration (Top View)

1.3.1 20-pin products

- 20-pin plastic LSSOP (4.4 × 6.5 mm, 0.65 mm pitch)
- 20-pin plastic TSSOP (4.4 × 6.5 mm, 0.65 mm pitch)

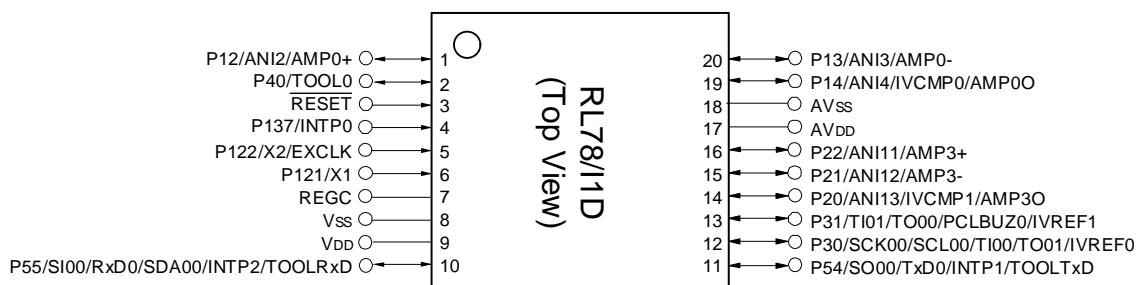

Caution 1. Connect the REGC pin to Vss pin via a capacitor (0.47 to 1 μ F).

Caution 2. Make AVss pin the same potential as Vss pin.

Caution 3. Make AVDD pin the same potential as VDD pin.

Remark For pin identification, see 1.4 Pin Identification.

1.3.2 24-pin products

- 24-pin plastic HWQFN (4 × 4 mm, 0.5 mm pitch)

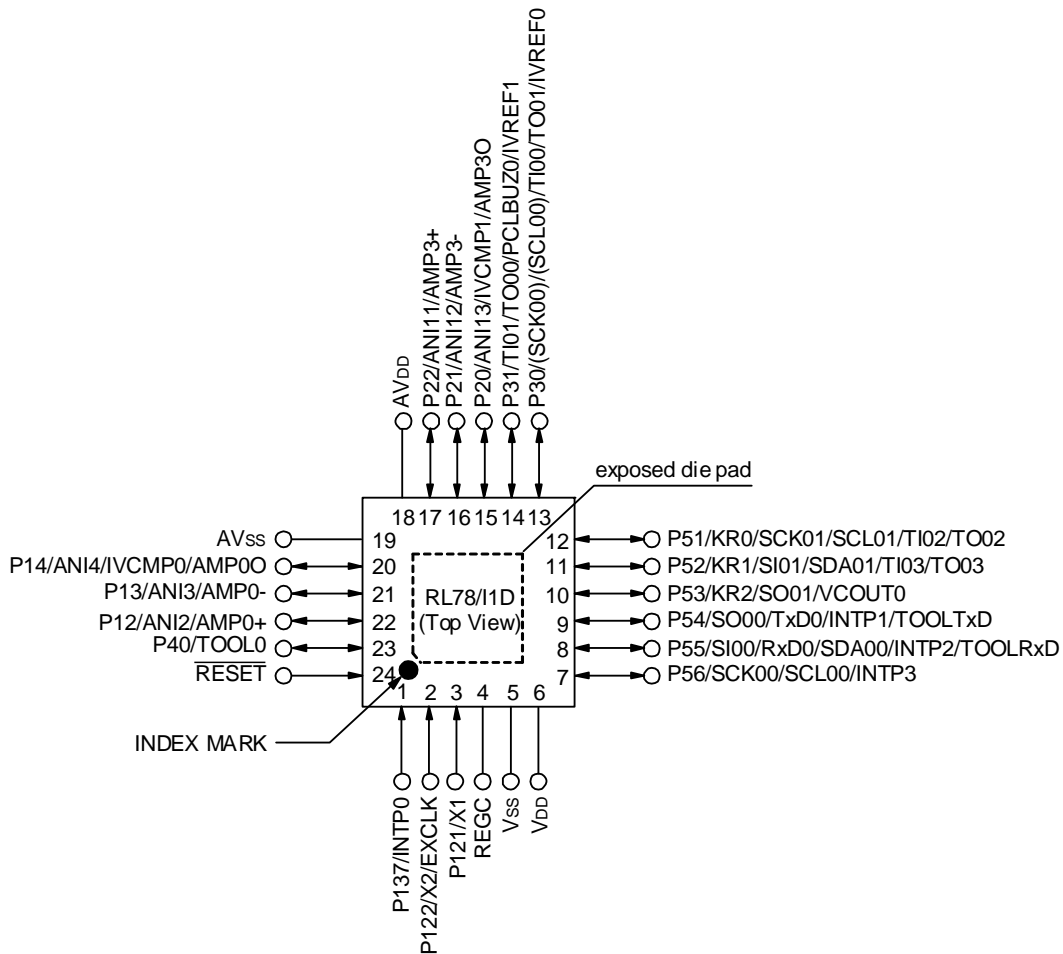

Caution 1. Connect the REGC pin to Vss pin via a capacitor (0.47 to 1 μF).

Caution 2. Make AVss pin the same potential as Vss pin.

Caution 3. Make AVDD pin the same potential as VDD pin.

Remark 1. For pin identification, see 1.4 Pin Identification.

Remark 2. It is recommended to connect an exposed die pad to Vss.

Remark 3. Functions in parentheses in the above figure can be assigned via settings in the peripheral I/O redirection register 0 (PIOR0).

1.3.3 30-pin products

- 30-pin plastic LSSOP (7.62 mm (300), 0.65 mm pitch)

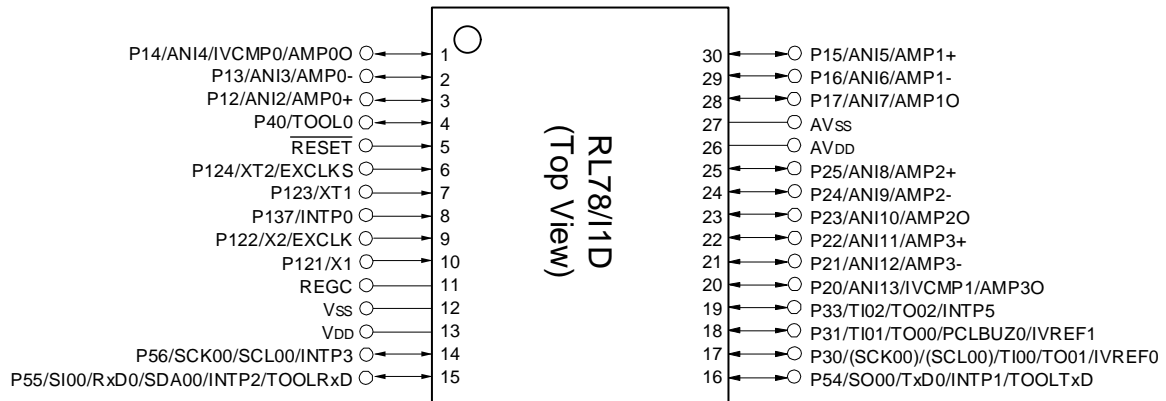

Caution 1. Connect the REGC pin to Vss pin via a capacitor (0.47 to 1 μ F).

Caution 2. Make AVss pin the same potential as Vss pin.

Caution 3. Make AVDD pin the same potential as VDD pin.

Remark 1. For pin identification, see 1.4 Pin Identification.

Remark 2. Functions in parentheses in the above figure can be assigned via settings in the peripheral I/O redirection register 0 (PIOR0).

1.3.4 32-pin products

- 32-pin plastic HVQFN (5 × 5 mm, 0.5 mm pitch)

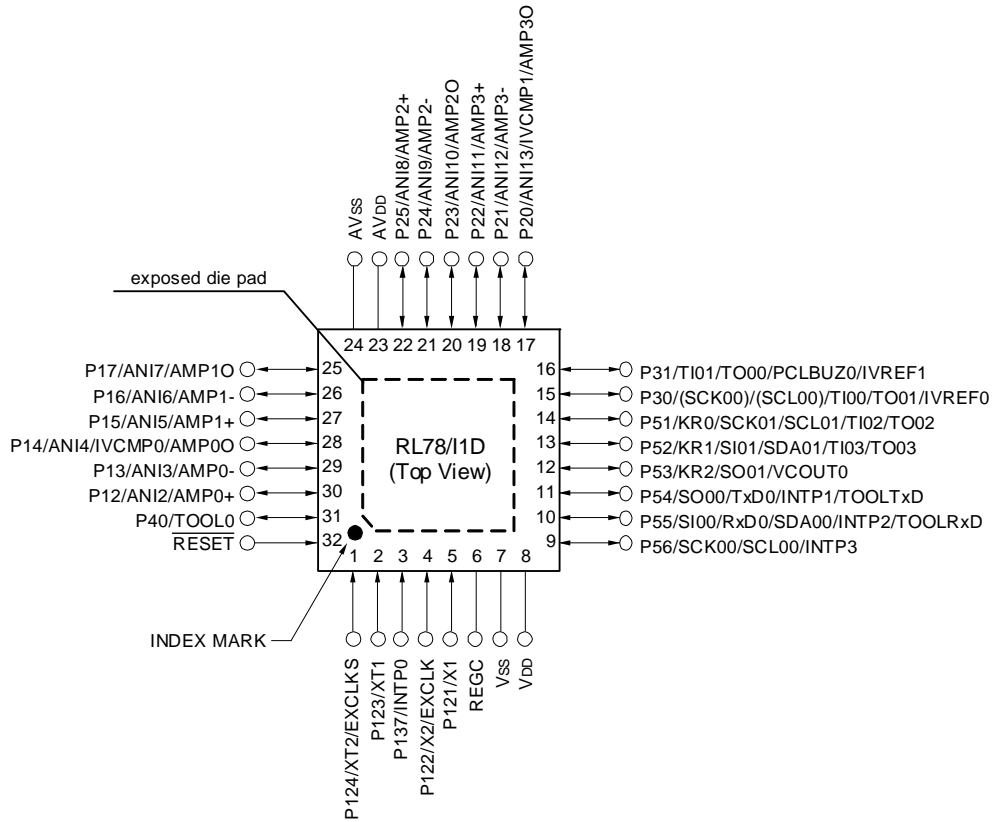

Caution 1. Connect the REGC pin to Vss pin via a capacitor (0.47 to 1 μF).

Caution 2. Make AVss pin the same potential as Vss pin.

Caution 3. Make AVDD pin the same potential as VDD pin.

Remark 1. For pin identification, see 1.4 Pin Identification.

Remark 2. Functions in parentheses in the above figure can be assigned via settings in the peripheral I/O redirection register 0 (PIOR0).

Remark 3. It is recommended to connect an exposed die pad to Vss.

- 32-pin plastic LQFP (7 × 7 mm, 0.8 mm pitch)

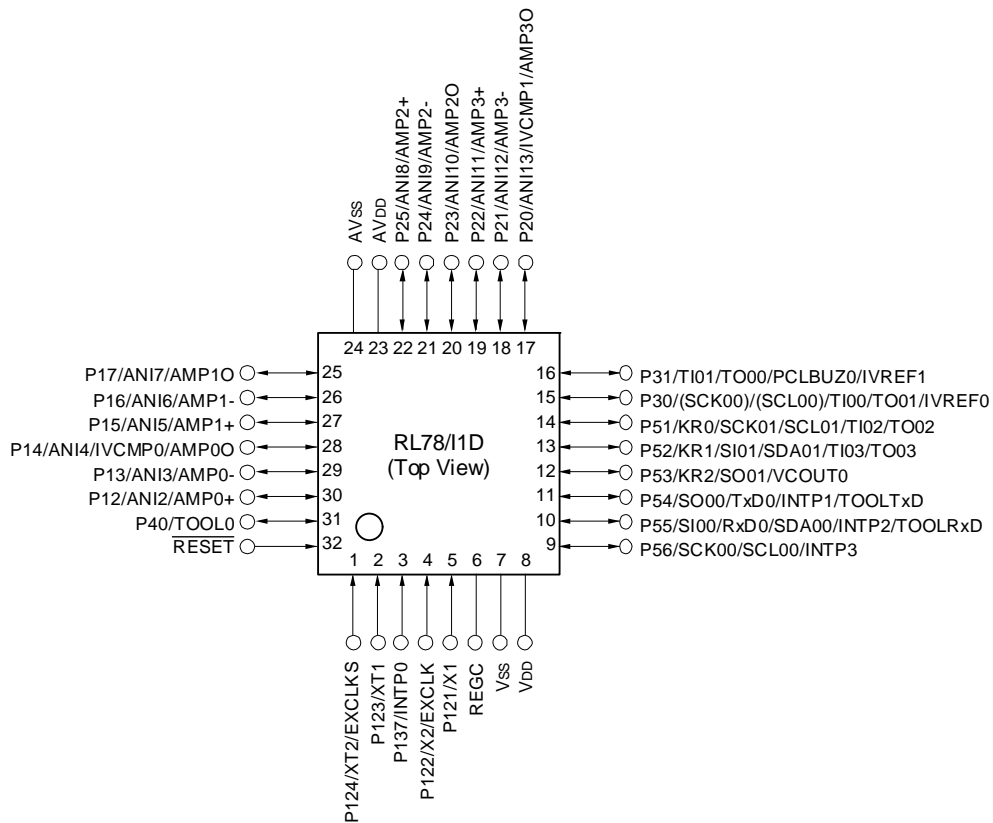

- Caution 1.** Connect the REGC pin to Vss pin via a capacitor (0.47 to 1 μF).
- Caution 2.** Make AVss pin the same potential as Vss pin.
- Caution 3.** Make AVDD pin the same potential as VDD pin.

Remark 1. For pin identification, see 1.4 Pin Identification.

Remark 2. Functions in parentheses in the above figure can be assigned via settings in the peripheral I/O redirection register 0 (PIOR0).

1.3.5 48-pin products

- 48-pin plastic LQFP (7 × 7 mm, 0.5 mm pitch)

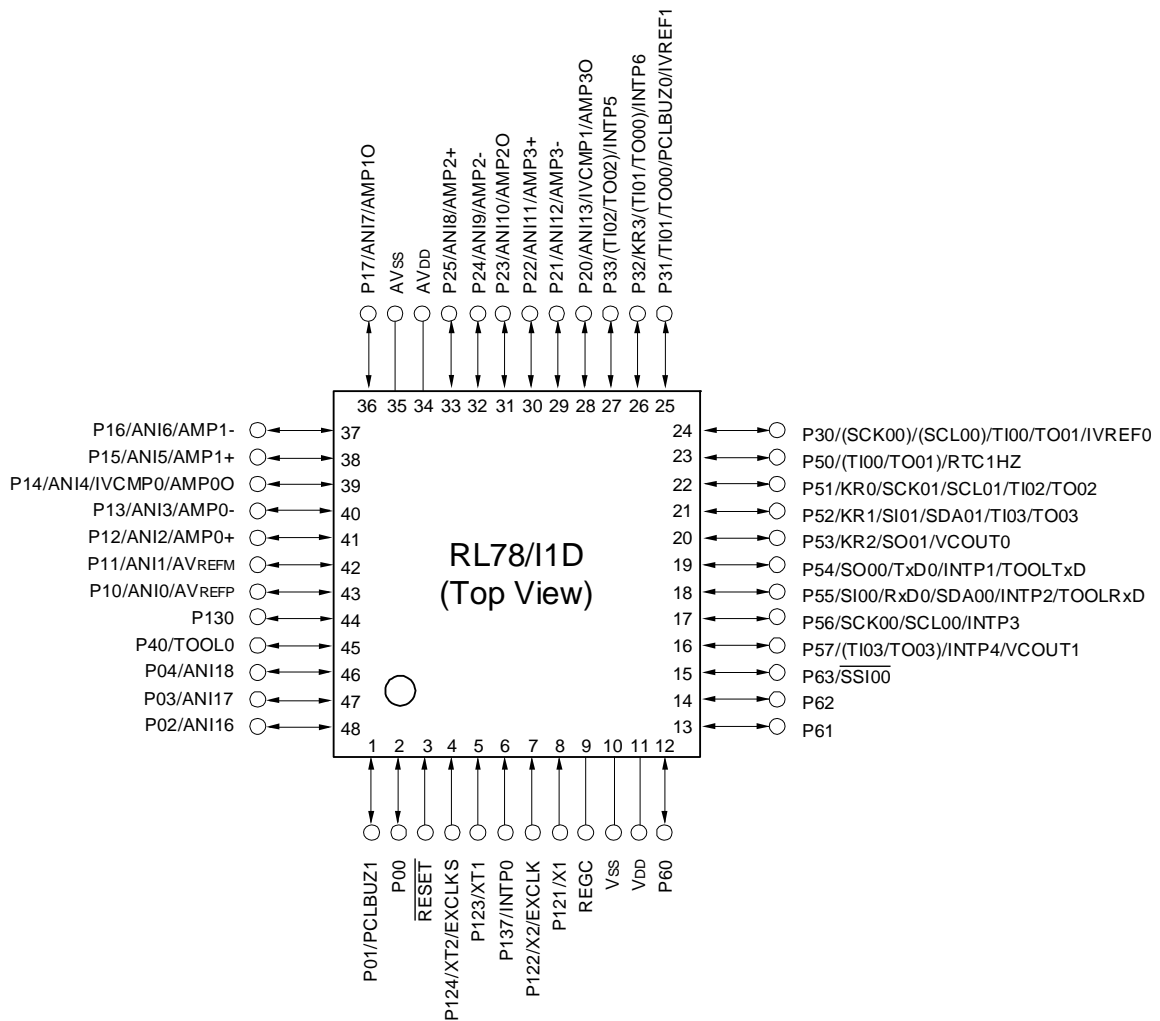

Caution 1. Connect the REGC pin to Vss pin via a capacitor (0.47 to 1 μF).

Caution 2. Make AVSS pin the same potential as VSS pin.

Caution 3. Make AVDD pin the same potential as VDD pin.

Remark 1. For pin identification, see 1.4 Pin Identification.

Remark 2. Functions in parentheses in the above figure can be assigned via settings in the peripheral I/O redirection register 0 (PIOR0).

1.4 Pin Identification

ANI0 to ANI13,		PCLBUZ0, PCLBUZ1	: Programmable clock output/buzzer output
ANI16 to ANI18	: Analog input	REGC	: Regulator capacitance
AVDD	: Analog power supply	$\overline{\text{RESET}}$: Reset
AVREFM	: A/D converter reference potential (- side) input	RTC1HZ	: Real-time clock correction clock (1 Hz) output
AVREFP	: A/D converter reference potential (+ side) input	RxD0	: Receive data
AVSS	: Analog ground	SCK00, SCK01	: Serial clock input/output
EXCLK	: External clock input (main system clock)	SCL00, SCL01	: Serial clock input/output
EXCLKS	: External clock input (subsystem clock)	SDA00, SDA01	: Serial data input/output
INTP0 to INTP6	: External interrupt input	SI00, SI01	: Serial data input
IVCMP0, IVCMP1	: Comparator input	SO00, SO01	: Serial data output
IVREF0, IVREF1	: Comparator reference input	$\overline{\text{SSI00}}$: Serial interface chip select input
KR0 to KR3	: Key return	TI00 to TI03	: Timer input
P00 to P04	: Port 0	TO00 to TO03	: Timer output
P10 to P17	: Port 1	TOOL0	: Data input/output for tool
P20 to P25	: Port 2	TOOLRxD, TOOLTxD	: Data input/output for external device
P30 to P33	: Port 3	TxD0	: Transmit data
P40	: Port 4	VCOU0, VCOU1	: Comparator output
P50 to P57	: Port 5	AMP0+, AMP1+, AMP2+, AMP3+	: Operational amplifier (+side) input
P60 to P63	: Port 6	AMP0-, AMP1-, AMP2-, AMP3-	: Operational amplifier (-side) input
P121 to P124	: Port 12	AMP0O, AMP1O, AMP2O, AMP3O	: Operational amplifier output
P130, P137	: Port 13	VDD	: Power supply
		VSS	: Ground
		X1, X2	: Crystal oscillator (main system clock)
		XT1, XT2	: Crystal oscillator (subsystem clock)

1.5 Block Diagram

1.5.1 48-pin products

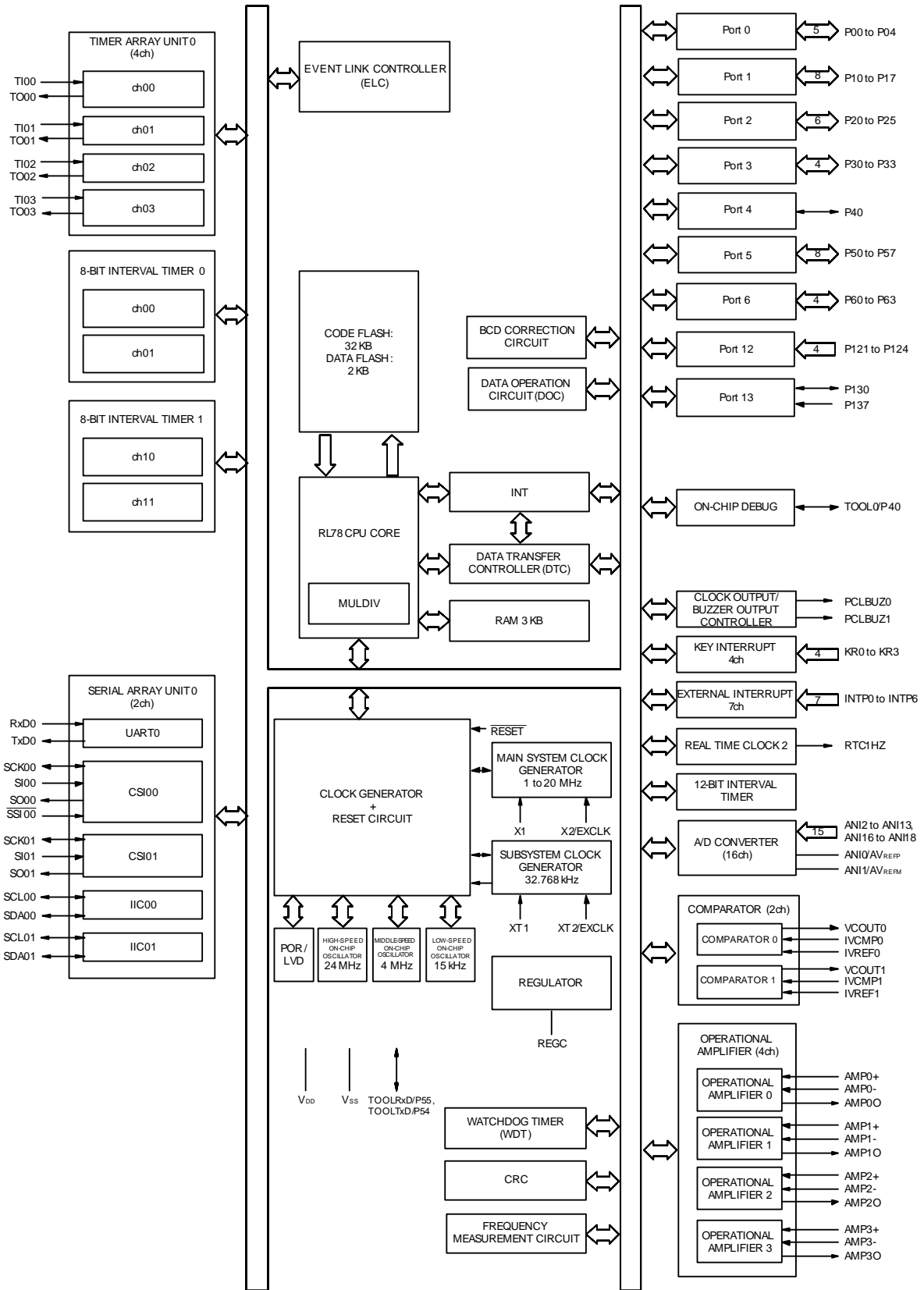

1.6 Outline of Functions

Remark This outline describes the functions at the time when Peripheral I/O redirection register 0 (PIOR0) are set to 00H.

(1/2)

Item		20-pin	24-pin	30-pin	32-pin	48-pin
		R5F1176x (x = 8, A)	R5F1177x (x = 8, A)	R5F117Ax (x = 8, A, C)	R5F117Bx (x = A, C)	R5F117Gx (x = A, C)
Code flash memory (KB)		8 to 16 KB	8 to 16 KB	8 to 32 KB	16 to 32 KB	16 to 32 KB
Data flash memory (KB)		2 KB	2 KB	2 KB	2 KB	2 KB
RAM		0.7 to 2.0 KB	0.7 to 2.0 KB	0.7 to 3.0 KB Note	2.0 to 3.0 KB Note	2.0 to 3.0 KB Note
Address space		1 MB				
Main system clock	High-speed system clock (f _{MX})	X1 (crystal/ceramic) oscillation, external main system clock input (EXCLK) HS (High-speed main) mode: 1 to 20 MHz (V _{DD} = 2.7 to 3.6 V), HS (High-speed main) mode: 1 to 16 MHz (V _{DD} = 2.4 to 3.6 V), LS (Low-speed main) mode: 1 to 8 MHz (V _{DD} = 1.8 to 3.6 V), LV (Low-voltage main) mode: 1 to 4 MHz (V _{DD} = 1.6 to 3.6 V), LP (Low-power main) mode: 1 MHz (V _{DD} = 1.8 to 3.6 V)				
	High-speed on-chip oscillator clock (f _{IH}) Max: 24 MHz	HS (High-speed main) mode: 1 to 24 MHz (V _{DD} = 2.7 to 3.6 V), HS (High-speed main) mode: 1 to 16 MHz (V _{DD} = 2.4 to 3.6 V), LS (Low-speed main) mode: 1 to 8 MHz (V _{DD} = 1.8 to 3.6 V), LV (Low-voltage main) mode: 1 to 4 MHz (V _{DD} = 1.6 to 3.6 V), LP (Low-power main) mode: 1 MHz (V _{DD} = 1.8 to 3.6 V)				
	Middle-speed on-chip oscillator clock (f _{IM}) Max: 4 MHz	LV (Low-voltage main) mode: 1 to 4 MHz (V _{DD} = 1.6 to 3.6 V), LP (Low-power main) mode: 1 MHz (V _{DD} = 1.8 to 3.6 V)				
Subsystem clock	Subsystem clock oscillator (f _{SX} , f _{SXR})	—		XT1 (crystal) oscillation 32.768 kHz (TYP.): V _{DD} = 1.6 to 3.6 V		
	Low-speed on-chip oscillator clock (f _L)	15 kHz (TYP.): V _{DD} = 1.6 to 3.6 V				
General-purpose register		8 bits × 32 registers (8 bits × 8 registers × 4 banks)				
Minimum instruction execution time		0.04167 μs (High-speed on-chip oscillator clock: f _{IH} = 24 MHz operation)				
		0.05 μs (High-speed system clock: f _{MX} = 20 MHz operation)				
		—		30.5 μs (Subsystem clock oscillator clock: f _{SX} = 32.768 kHz operation)		
Instruction set		<ul style="list-style-type: none"> • Data transfer (8/16 bits) • Adder and subtractor/logical operation (8/16 bits) • Multiplication (8 bits × 8 bits, 16 bits × 16 bits), Division (16 bits ÷ 16 bits, 32 bits ÷ 32 bits) • Multiplication and Accumulation (16 bits × 16 bits + 32 bits) • Rotate, barrel shift, and bit manipulation (Set, reset, test, and Boolean operation), etc. 				
I/O port	Total	14	18	24	26	42
	CMOS I/O	11	15	19	21	33
	CMOS input	3	3	5	5	5
	N-ch open-drain I/O (6 V tolerance)	—	—	—	—	4
Timer	16-bit timer	4 channels				
	Watchdog timer	1 channel				
	Real-time clock	1 channel				
	12-bit interval timer	1 channel				
	8/16-bit interval timer	4 channels (8 bit) / 2 channels (16 bit)				
	Timer output	2	4	3	4	4
	RTC output	—		1 channel • 1 Hz (subsystem clock generator and RTC2/other clock: f _{SX} = 32.768 kHz)		

Note The flash library uses RAM in self-programming and rewriting of the data flash memory. The target products and start address of the RAM areas used by the flash library are shown below.

R5F117xC (x = A, B, G): Start address FF300H

For the RAM areas used by the flash library, see **Self RAM list of Flash Self-Programming Library for RL78 Family (R20UT2944)**.

(2/2)

Item	20-pin	24-pin	30-pin	32-pin	48-pin
	R5F1176x (x = 8, A)	R5F1177x (x = 8, A)	R5F117Ax (x = 8, A, C)	R5F117Bx (x = A, C)	R5F117Gx (x = A, C)
Clock output/buzzer output	1	1	1	1	2
	[20-pin, 24-pin products] • 2.44 kHz, 4.88 kHz, 9.76 kHz, 1.25 MHz, 2.5 MHz, 5 MHz, 10 MHz (Main system clock: $f_{MAIN} = 20$ MHz operation) [30-pin, 32-pin, 48-pin products] • 2.44 kHz, 4.88 kHz, 9.76 kHz, 1.25 MHz, 2.5 MHz, 5 MHz, 10 MHz (Main system clock: $f_{MAIN} = 20$ MHz operation) • 256 Hz, 512 Hz, 1.024 kHz, 2.048 kHz, 4.096 kHz, 8.192 kHz, 16.384 kHz, 32.768 kHz (subsystem clock generator and RTC/other clock: $f_{SXR} = 32.768$ kHz operation)				
12-bit resolution A/D converter	6 channels	6 channels	12 channels	12 channels	17 channels
Comparator (Window Comparator)	2 channels				
Operational amplifier	2 channels		4 channels		
Data Operation Circuit (DOC)	Comparison, addition, and subtraction of 16-bit data				
Serial interface	[20-pin, 30-pin products] • Simplified SPI (CSI): 1 channel/UART: 1 channel/simplified I ² C: 1 channel [24-pin, 32-pin, 48-pin products] • Simplified SPI (CSI): 2 channels/UART: 1 channel/simplified I ² C: 2 channels				
Data transfer controller (DTC)	16 sources	20 sources	19 sources	20 sources	22 sources
Event link controller (ELC)	Event input: 15 Event trigger output: 5	Event input: 17 Event trigger output: 5	Event input: 17 Event trigger output: 7	Event input: 17 Event trigger output: 7	Event input: 20 Event trigger output: 7
Vectored interrupt sources	Internal	22	22	24	24
	External	3	5	5	5
Key interrupt	—	3	—	3	4
Reset	<ul style="list-style-type: none"> Reset by \overline{RESET} pin Internal reset by watchdog timer Internal reset by power-on-reset Internal reset by voltage detector Internal reset by illegal instruction execution ^{Note} Internal reset by RAM parity error Internal reset by illegal-memory access 				
Power-on-reset circuit	<ul style="list-style-type: none"> Power-on-reset: 1.51 ± 0.04 V ($T_A = -40$ to $+85^\circ\text{C}$) Power-down-reset: 1.50 ± 0.04 V ($T_A = -40$ to $+85^\circ\text{C}$) 				
Voltage detector	Power on	1.67 V to 3.13 V (12 stages)			
	Power down	1.63 V to 3.06 V (12 stages)			
On-chip debug function	Provided (Enable to tracing)				
Power supply voltage	$V_{DD} = 1.6$ to 3.6 V				
Operating ambient temperature	$T_A = -40$ to $+105^\circ\text{C}$				

The illegal instruction is generated when instruction code FFH is executed.

Reset by the illegal instruction execution is not issued by emulation with the in-circuit emulator or on-chip debug emulator.

2. ELECTRICAL SPECIFICATIONS

- Caution 1.** The RL78 microcontrollers have an on-chip debug function, which is provided for development and evaluation. Do not use the on-chip debug function in products designated for mass production, because the guaranteed number of rewritable times of the flash memory may be exceeded when this function is used, and product reliability therefore cannot be guaranteed. Renesas Electronics is not liable for problems occurring when the on-chip debug function is used.
- Caution 2.** The pins mounted depend on the product. Refer to 2.1 Port Functions to 2.2.1 Functions for each product in the RL78/I1D User's Manual.
- Caution 3.** Please contact Renesas Electronics sales office for derating of operation under $T_A = +85$ to $+105^\circ\text{C}$. Derating is the systematic reduction of load for the sake of improved reliability.
- Caution 4.** When operating temperature exceeds 85°C , only HS (high-speed main) mode can be used as the flash operation mode. Regulator mode should be used with the normal setting (MCSEL = 0).

2.1 Absolute Maximum Ratings

Absolute Maximum Ratings

(1/2)

Parameter	Symbols	Conditions	Ratings	Unit
Supply voltage	V_{DD} , AV_{DD}	$V_{DD} = AV_{DD}$	-0.3 to + 4.6	V
	AV_{REFP}		0.3 to $AV_{DD} + 0.3$ Note 2	V
	AV_{SS}		-0.5 to + 0.3	V
	AV_{REFM}		-0.3 to $AV_{DD} + 0.3$ Note 2 and $AV_{REFM} \leq AV_{REFP}$	V
REGC pin input voltage	V_{IREGC}	REGC	-0.3 to + 2.8 and -0.3 to $V_{DD} + 0.3$ Note 1	V
Input voltage	V_{I1}	P00 to P04, P30 to P33, P40, P50 to P57, P121 to P124, P130, P137, EXCLK, EXCLKS, \overline{RESET}	-0.3 to $V_{DD} + 0.3$ Note 2	V
	V_{I2}	P60 to P63 (N-ch open-drain)	-0.3 to + 6.5	V
	V_{I3}	P10 to P17, P20 to P25	-0.3 to $AV_{DD} + 0.3$ Note 2	V
Output voltage	V_{O1}	P00 to P04, P30 to P33, P40, P50 to P57, P60 to P63, P130	-0.3 to $V_{DD} + 0.3$ Note 2	V
	V_{O2}	P10 to P17, P20 to P25	-0.3 to $AV_{DD} + 0.3$ Note 2	V
Analog input voltage	V_{AI1}	ANI16 to ANI18	-0.3 to $V_{DD} + 0.3$ and -0.3 to $AV_{REF}(+) + 0.3$ Notes 2, 3	V
	V_{AI2}	ANI0 to ANI13	-0.3 to $AV_{DD} + 0.3$ and -0.3 to $AV_{REF}(+) + 0.3$ Notes 2, 3	V
	V_{AI3}	Operational amplifier input pin	-0.3 to $AV_{DD} + 0.3$ Note 2	V

Note 1. Connect the REGC pin to V_{SS} via a capacitor (0.47 to 1 μ F). This value regulates the absolute maximum rating of the REGC pin. Do not use this pin with voltage applied to it.

Note 2. Must be 4.6 V or lower.

Note 3. Do not exceed $AV_{REF}(+) + 0.3$ V in case of A/D conversion target pin.

Caution Product quality may suffer if the absolute maximum rating is exceeded even momentarily for any parameter. That is, the absolute maximum ratings are rated values at which the product is on the verge of suffering physical damage, and therefore the product must be used under conditions that ensure that the absolute maximum ratings are not exceeded.

Remark 1. Unless specified otherwise, the characteristics of alternate-function pins are the same as those of the port pins.

Remark 2. $AV_{REF}(+)$: + side reference voltage of the A/D converter.

Remark 3. V_{SS} : Reference voltage

Absolute Maximum Ratings**(2/2)**

Parameter	Symbols	Conditions		Ratings	Unit
Output current, high	IOH1	Per pin	P00 to P04, P30 to P33, P40, P50 to P57, P130	-40	mA
		Total of all pins -170 mA	P00 to P04, P40, P130	-70	mA
			P30 to P33, P50 to P57	-100	mA
	IOH2	Per pin	P10 to P17, P20 to P25	-0.1	mA
		Total of all pins		-1.4	mA
	Output current, low	IOL1	Per pin	P00 to P04, P30 to P33, P40, P50 to P57, P60 to P63, P130	40
Total of all pins 170 mA			P00 to P04, P40, P130	70	mA
			P30 to P33, P50 to P57, P60 to P63	100	mA
IOL2		Per pin	P10 to P17, P20 to P25	0.4	mA
		Total of all pins		5.6	mA
Operating ambient temperature		TA	In normal operation mode		-40 to +105
	In flash memory programming mode				
Storage temperature	T _{stg}			-65 to +150	°C

Caution Product quality may suffer if the absolute maximum rating is exceeded even momentarily for any parameter. That is, the absolute maximum ratings are rated values at which the product is on the verge of suffering physical damage, and therefore the product must be used under conditions that ensure that the absolute maximum ratings are not exceeded.

Remark Unless specified otherwise, the characteristics of alternate-function pins are the same as those of the port pins.

2.2 Oscillator Characteristics

2.2.1 X1, XT1 characteristics

(TA = -40 to +85°C, 1.6 V ≤ AVDD = VDD ≤ 3.6 V, VSS = AVSS = 0 V)

(TA = +85 to +105°C, 2.4 V ≤ AVDD = VDD ≤ 3.6 V, VSS = AVSS = 0 V)

Resonator	Resonator	Conditions	MIN.	TYP.	MAX.	Unit
X1 clock oscillation frequency (f _X) ^{Note}	Ceramic resonator/ crystal resonator	2.7 V ≤ V _{DD} ≤ 3.6 V	1.0		20.0	MHz
		2.4 V ≤ V _{DD} < 2.7 V	1.0		16.0	
		1.8 V ≤ V _{DD} < 2.4 V	1.0		8.0	
		1.6 V ≤ V _{DD} < 1.8 V	1.0		4.0	
XT1 clock oscillation frequency (f _{XT}) ^{Note}	Crystal resonator		32	32.768	35	kHz

Note Indicates only permissible oscillator frequency ranges. Refer to **AC Characteristics** for instruction execution time. Request evaluation by the manufacturer of the oscillator circuit mounted on a board to check the oscillator characteristics.

Caution Since the CPU is started by the high-speed on-chip oscillator clock after a reset release, check the X1 clock oscillation stabilization time using the oscillation stabilization time counter status register (OSTC) by the user. Determine the oscillation stabilization time of the OSTC register and the oscillation stabilization time select register (OSTS) after sufficiently evaluating the oscillation stabilization time with the resonator to be used.

Remark When using the X1 oscillator and XT1 oscillator, refer to **6.4 System Clock Oscillator** in the RL78/I1D User's Manual.

2.2.2 On-chip oscillator characteristics

(TA = -40 to +85°C, 1.6 V ≤ AVDD = VDD ≤ 3.6 V, VSS = AVSS = 0 V)

(TA = +85 to +105°C, 2.4 V ≤ AVDD = VDD ≤ 3.6 V, VSS = AVSS = 0 V)

Oscillators	Parameters	Conditions	MIN.	TYP.	MAX.	Unit	
High-speed on-chip oscillator clock frequency ^{Notes 1, 2}	f _{IH}		1		24	MHz	
High-speed on-chip oscillator clock frequency accuracy		-20 to +85°C	1.8 V ≤ V _{DD} ≤ 3.6 V	-1.0		+1.0	%
			1.6 V ≤ V _{DD} < 1.8 V	-5.0		+5.0	
		-40 to -20°C	1.8 V ≤ V _{DD} ≤ 3.6 V	-1.5		+1.5	%
			1.6 V ≤ V _{DD} < 1.8 V	-5.5		+5.5	
+85 to +105°C	2.4 V ≤ V _{DD} ≤ 3.6 V	-2.0		+2.0	%		
Middle-speed on-chip oscillator oscillation frequency ^{Note 2}	f _{IM}		1		4	MHz	
Middle-speed on-chip oscillator oscillation frequency accuracy		1.8V ≤ V _{DD} ≤ 3.6V	-12		+12	%	
Low-speed on-chip oscillator clock frequency ^{Note 2}	f _{IL}			15		kHz	
Low-speed on-chip oscillator clock frequency accuracy			-15		+15	%	

Note 1. High-speed on-chip oscillator frequency is selected with bits 0 to 3 of the option byte (000C2H) and bits 0 to 2 of the HOCODIV register.

Note 2. This only indicates the oscillator characteristics. Refer to **AC Characteristics** for instruction execution time.

2.3 DC Characteristics

2.3.1 Pin characteristics

(TA = -40 to +85°C, 1.6 V ≤ AVDD = VDD ≤ 3.6 V, VSS = AVSS = 0 V)

(TA = +85 to +105°C, 2.4 V ≤ AVDD = VDD ≤ 3.6 V, VSS = AVSS = 0 V)

(1/5)

Items	Symbol	Conditions	MIN.	TYP.	MAX.	Unit	
Output current, high Note 1	IOH1	Per pin for P00 to P04, P30 to P33, P40, P50 to P57, P130	TA = -40 to +85°C			-10.0 Note 2	mA
			TA = +85 to +105°C			-3.0 Note 2	mA
	Total of P00 to P04, P40, P130 (When duty ≤ 70% Note 3)	2.7 V ≤ VDD ≤ 3.6 V			-10.0	mA	
		1.8 V ≤ VDD < 2.7 V			-5.0	mA	
		1.6 V ≤ VDD < 1.8 V			-2.5	mA	
	Total of P30 to P33, P50 to P57 (When duty ≤ 70% Note 3)	2.7 V ≤ VDD ≤ 3.6 V			-19.0	mA	
		1.8 V ≤ VDD < 2.7 V			-10.0	mA	
		1.6 V ≤ VDD < 1.8 V			-5.0	mA	
	Total of all pins (When duty ≤ 70% Note 3)				-29.0	mA	
	IOH2	Per pin for P10 to P17, P20 to P25				-0.1 Note 2	mA
Total of all pins (When duty ≤ 70% Note 3)			1.6 V ≤ VDD ≤ 3.6 V			-1.4	mA

Note 1. Value of current at which the device operation is guaranteed even if the current flows from the VDD pin to an output pin.

Note 2. Do not exceed the total current value.

Note 3. Specification under conditions where the duty factor ≤ 70%.

The output current value that has changed to the duty factor > 70% the duty ratio can be calculated with the following expression (when changing the duty factor from 70% to n%).

- Total output current of pins = $(I_{OH} \times 0.7)/(n \times 0.01)$

<Example> Where n = 80% and IOH = -10.0 mA

$$\text{Total output current of pins} = (-10.0 \times 0.7)/(80 \times 0.01) \approx -8.7 \text{ mA}$$

However, the current that is allowed to flow into one pin does not vary depending on the duty factor.

A current higher than the absolute maximum rating must not flow into one pin.

Caution P30 and P51 to P56 do not output high level in N-ch open-drain mode.

Remark Unless specified otherwise, the characteristics of alternate-function pins are the same as those of the port pins.

(TA = -40 to +85°C, 1.6 V ≤ AVDD = VDD ≤ 3.6 V, VSS = AVSS = 0 V)

(TA = +85 to +105°C, 2.4 V ≤ AVDD = VDD ≤ 3.6 V, VSS = AVSS = 0 V)

(2/5)

Items	Symbol	Conditions	MIN.	TYP.	MAX.	Unit
Output current, low Note 1	IOL1	Per pin for P00 to P04, P30 to P33, P40, P50 to P57, P130	TA = -40 to +85°C		20.0 Note 2	mA
			TA = +85 to +105°C		8.5 Note 2	mA
		Per pin for P60 to P63			15.0 Note 2	mA
		Total of P00 to P04, P40, P130 (When duty ≤ 70% Note 3)	2.7 V ≤ VDD ≤ 3.6 V		15.0	mA
			1.8 V ≤ VDD < 2.7 V		9.0	mA
			1.6 V ≤ VDD < 1.8 V		4.5	mA
		Total of P30 to P33, P50 to P57, P60 to P63 (When duty ≤ 70% Note 3)	2.7 V ≤ VDD ≤ 3.6 V		35.0	mA
			1.8 V ≤ VDD < 2.7 V		20.0	mA
			1.6 V ≤ VDD < 1.8 V		10.0	mA
	Total of all pins (When duty ≤ 70% Note 3)			50.0	mA	
	IOL2	Per pin for P10 to P17, P20 to P25			0.4 Note 2	mA
			1.6 V ≤ VDD ≤ 3.6 V		5.6	mA
		Total of all pins (When duty ≤ 70% Note 3)				

Note 1. Value of current at which the device operation is guaranteed even if the current flows from an output pin to the VSS pin.

Note 2. Do not exceed the total current value.

Note 3. Specification under conditions where the duty factor ≤ 70%.

The output current value that has changed to the duty factor > 70% the duty ratio can be calculated with the following expression (when changing the duty factor from 70% to n%).

- Total output current of pins = (IOL × 0.7)/(n × 0.01)

<Example> Where n = 80% and IOL = 10.0 mA

$$\text{Total output current of pins} = (10.0 \times 0.7)/(80 \times 0.01) \approx 8.7 \text{ mA}$$

However, the current that is allowed to flow into one pin does not vary depending on the duty factor.

A current higher than the absolute maximum rating must not flow into one pin.

Remark Unless specified otherwise, the characteristics of alternate-function pins are the same as those of the port pins.

(TA = -40 to +85°C, 1.6 V ≤ AVDD = VDD ≤ 3.6 V, VSS = AVSS = 0 V)

(TA = +85 to +105°C, 2.4 V ≤ AVDD = VDD ≤ 3.6 V, VSS = AVSS = 0 V)

(3/5)

Items	Symbol	Conditions	MIN.	TYP.	MAX.	Unit	
Input voltage, high	VIH1	P00 to P04, P30 to P33, P40, P50 to P57, P130	Normal input buffer	0.8 VDD		VDD	V
	VIH2	P30, P32, P33, P51, P52, P54 to P57	TTL input buffer 3.3 V ≤ VDD ≤ 3.6 V	2.0		VDD	V
			TTL input buffer 1.6 V ≤ VDD < 3.3 V	1.5		VDD	V
	VIH3	P10 to P17, P20 to P25		0.7 AVDD		AVDD	V
	VIH4	P60 to P63		0.7 VDD		6.0	V
	VIH5	P121 to P124, P137, EXCLK, EXCLKS, RESET		0.8 VDD		VDD	V
Input voltage, low	VIL1	P00 to P04, P30 to P33, P40, P50 to P57, P130	Normal input buffer	0		0.2 VDD	V
	VIL2	P30, P32, P33, P51, P52, P54 to P57	TTL input buffer 3.3 V ≤ VDD ≤ 3.6 V	0		0.5	V
			TTL input buffer 1.6 V ≤ VDD < 3.3 V	0		0.32	V
	VIL3	P10 to P17, P20 to P25		0		0.3 AVDD	V
	VIL4	P60 to P63		0		0.3 VDD	V
	VIL5	P121 to P124, P137, EXCLK, EXCLKS, RESET		0		0.2 VDD	V

Caution The maximum value of VIH of pins P30 and P51 to P56 is VDD, even in the N-ch open-drain mode.

Remark Unless specified otherwise, the characteristics of alternate-function pins are the same as those of the port pins.

($T_A = -40$ to $+85^\circ\text{C}$, $1.6\text{ V} \leq AV_{DD} = V_{DD} \leq 3.6\text{ V}$, $V_{SS} = AV_{SS} = 0\text{ V}$)

($T_A = +85$ to $+105^\circ\text{C}$, $2.4\text{ V} \leq AV_{DD} = V_{DD} \leq 3.6\text{ V}$, $V_{SS} = AV_{SS} = 0\text{ V}$)

(4/5)

Items	Symbol	Conditions	MIN.	TYP.	MAX.	Unit
Output voltage, high	VOH1	P00 to P04, P30 to P33, P40, P50 to P57, P130	$2.7\text{ V} \leq V_{DD} \leq 3.6\text{ V}$, $I_{OH} = -2.0\text{ mA}$		$V_{DD} - 0.6$	V
			$1.8\text{ V} \leq V_{DD} \leq 3.6\text{ V}$ Note 3, $I_{OH} = -1.5\text{ mA}$		$V_{DD} - 0.5$	V
			$1.6\text{ V} \leq V_{DD} \leq 3.6\text{ V}$ Note 1, $I_{OH} = -1.0\text{ mA}$		$V_{DD} - 0.5$	V
	VOH2	P10 to P17, P20 to P25	$1.6\text{ V} \leq AV_{DD} \leq 3.6\text{ V}$ Note 2, $I_{OH} = -100\text{ }\mu\text{A}$		$AV_{DD} - 0.5$	V
Output voltage, low	VOL1	P00 to P04, P30 to P33, P40, P50 to P57, P130	$2.7\text{ V} \leq V_{DD} \leq 3.6\text{ V}$, $I_{OL} = 3.0\text{ mA}$		0.6	V
			$2.7\text{ V} \leq V_{DD} \leq 3.6\text{ V}$, $I_{OL} = 1.5\text{ mA}$		0.4	V
			$1.8\text{ V} \leq V_{DD} \leq 3.6\text{ V}$ Note 3, $I_{OL} = 0.6\text{ mA}$		0.4	V
			$1.6\text{ V} \leq AV_{DD} \leq 3.6\text{ V}$ Note 1, $I_{OL} = 0.3\text{ mA}$		0.4	V
	VOL2	P10 to P17, P20 to P25	$1.6\text{ V} \leq AV_{DD} \leq 3.6\text{ V}$ Note 2, $I_{OL} = 400\text{ }\mu\text{A}$		0.4	V
	VOL3	P60 to P63	$2.7\text{ V} \leq V_{DD} \leq 3.6\text{ V}$, $I_{OL} = 3.0\text{ mA}$		0.4	V
			$1.8\text{ V} \leq V_{DD} \leq 3.6\text{ V}$ Note 3, $I_{OL} = 2.0\text{ mA}$		0.4	V
			$1.6\text{ V} \leq AV_{DD} \leq 3.6\text{ V}$ Note 1, $I_{OL} = 1.0\text{ mA}$		0.4	V

Note 1. Only $T_A = -40$ to $+85^\circ\text{C}$ is guaranteed.

Note 2. The condition that $2.4\text{ V} \leq AV_{DD} \leq 3.6\text{ V}$ is guaranteed when $+85^\circ\text{C} < T_A \leq +105^\circ\text{C}$.

Note 3. The condition that $2.4\text{ V} \leq V_{DD} \leq 3.6\text{ V}$ is guaranteed when $+85^\circ\text{C} < T_A \leq +105^\circ\text{C}$.

Caution P30 and P51 to P56 do not output high level in N-ch open-drain mode.

Remark Unless specified otherwise, the characteristics of alternate-function pins are the same as those of the port pins.

(TA = -40 to +85°C, 1.6 V ≤ AVDD = VDD ≤ 3.6 V, VSS = AVSS = 0 V)

(TA = +85 to +105°C, 2.4 V ≤ AVDD = VDD ≤ 3.6 V, VSS = AVSS = 0 V)

(5/5)

Items	Symbol	Conditions	MIN.	TYP.	MAX.	Unit		
Input leakage current, high	IIH1	P00 to P04, P30 to P33, P40, P50 to P57, P60 to P63, P130, P137	VI = VDD		1	μA		
	IIH2	RESET	VI = VDD		1	μA		
	IIH3	P121 to P124 (X1, X2, EXCLK, XT1, XT2, EXCLKS)	VI = VDD	In input port or external clock input		1	μA	
				In resonator connection		10	μA	
IIH4	P10 to P17, P20 to P25	VI = AVDD			1	μA		
Input leakage current, low	IIIL1	P00 to P04, P30 to P33, P40, P50 to P57, P60 to P63, P130, P137	VI = VSS		-1	μA		
	IIIL2	RESET	VI = VSS		-1	μA		
	IIIL3	P121 to P124 (X1, X2, EXCLK, XT1, XT2, EXCLKS)	VI = VSS	In input port or external clock input		-1	μA	
				In resonator connection		-10	μA	
IIIL4	P10 to P17, P20 to P25	VI = AVSS			-1	μA		
On-chip pull-up resistance	RU	P00 to P04, P30 to P33, P40, P50 to P57, P130	VI = VSS, In input port		10	20	100	kΩ

Remark Unless specified otherwise, the characteristics of alternate-function pins are the same as those of the port pins.

2.3.2 Supply current characteristics

(TA = -40 to +85°C, 1.6 V ≤ AVDD = VDD ≤ 3.6 V, VSS = AVSS = 0 V)

(TA = +85 to +105°C, 2.4 V ≤ AVDD = VDD ≤ 3.6 V, VSS = AVSS = 0 V)

(1/4)

Parameter	Symbol	Conditions					MIN.	TYP.	MAX.	Unit	
Supply current Note 1	IDD1	Operating mode	HS (high-speed main) mode	f _{IH} = 24 MHz Note 3, T _A = -40 to +105°C	Basic operation	V _{DD} = 3.0 V		1.4		mA	
			HS (high-speed main) mode	f _{IH} = 24 MHz Note 3, T _A = -40 to +85°C	Normal operation	V _{DD} = 3.0 V		3.2	6.3	mA	
				f _{IH} = 24 MHz Note 3, T _A = +85 to +105°C	Normal operation	V _{DD} = 3.0 V			6.7	mA	
				f _{IH} = 16 MHz Note 3, T _A = -40 to +85°C	Normal operation	V _{DD} = 3.0 V		2.4	4.6	mA	
				f _{IH} = 16 MHz Note 3, T _A = +85 to +105°C	Normal operation	V _{DD} = 3.0 V			4.9	mA	
				LS (low-speed main) mode (MCSEL = 0)	f _{IH} = 8 MHz Note 3, T _A = -40 to +85°C	Normal operation	V _{DD} = 3.0 V		1.1	2.0	mA
						V _{DD} = 2.0 V		1.1	2.0	mA	
			LS (low-speed main) mode (MCSEL = 1)	f _{IH} = 4 MHz Note 3, T _A = -40 to +85°C	Normal operation	V _{DD} = 3.0 V		0.72	1.30	mA	
						V _{DD} = 2.0 V		0.72	1.30	mA	
				f _{IM} = 4 MHz Note 7, T _A = -40 to +85°C	Normal operation	V _{DD} = 3.0 V		0.58	1.10	mA	
						V _{DD} = 2.0 V		0.58	1.10	mA	
			LV (low-voltage main) mode	f _{IH} = 3 MHz Note 3, T _A = -40 to +85°C	Normal operation	V _{DD} = 3.0 V		1.2	1.8	mA	
						V _{DD} = 2.0 V		1.2	1.8	mA	
			LP (low-power main) mode Note 5 (MCSEL = 1)	f _{IH} = 1 MHz Note 3, T _A = -40 to +85°C	Normal operation	V _{DD} = 3.0 V		290	480	μA	
						V _{DD} = 2.0 V		290	480	μA	
				f _{IM} = 1 MHz Note 5, T _A = -40 to +85°C	Normal operation	V _{DD} = 3.0 V		124	230	μA	
						V _{DD} = 2.0 V		124	230	μA	
			HS (high-speed main) mode	f _{MX} = 20 MHz Note 2, T _A = -40 to +85°C	Normal operation	V _{DD} = 3.0 V	Square wave input		2.7	5.3	mA
							Resonator connection		2.8	5.5	
					Normal operation	V _{DD} = 3.0 V	Square wave input			5.7	
							Resonator connection			5.8	
				f _{MX} = 10 MHz Note 2, T _A = -40 to +85°C	Normal operation	V _{DD} = 3.0 V	Square wave input		1.8	3.1	mA
							Resonator connection		1.9	3.2	
				f _{MX} = 10 MHz Note 2, T _A = +85 to +105°C	Normal operation	V _{DD} = 3.0 V	Square wave input			3.4	mA
							Resonator connection			3.5	
			LS (low-speed main) mode (MCSEL = 0)	f _{MX} = 8 MHz Note 2, T _A = -40 to +85°C	Normal operation	V _{DD} = 3.0 V	Square wave input		0.9	1.9	mA
							Resonator connection		1.0	2.0	
				f _{MX} = 8 MHz Note 2, T _A = -40 to +85°C	Normal operation	V _{DD} = 2.0 V	Square wave input		0.9	1.9	mA
							Resonator connection		1.0	2.0	
			LS (low-speed main) mode (MCSEL = 1)	f _{MX} = 4 MHz Note 2, T _A = -40 to +85°C	Normal operation	V _{DD} = 3.0 V	Square wave input		0.6	1.1	mA
							Resonator connection		0.6	1.2	
				f _{MX} = 4 MHz Note 2, T _A = -40 to +85°C	Normal operation	V _{DD} = 2.0 V	Square wave input		0.6	1.1	mA
Resonator connection		0.6					1.2				
LP (low-power main) mode (MCSEL = 1)	f _{MX} = 1 MHz Note 2, T _A = -40 to +85°C	Normal operation	V _{DD} = 3.0 V	Square wave input		100	190	μA			
				Resonator connection		136	250				
	f _{MX} = 1 MHz Note 2, T _A = -40 to +85°C	Normal operation	V _{DD} = 2.0 V	Square wave input		100	190	μA			
				Resonator connection		136	250				

(Notes and Remarks are listed on the next page.)

(TA = -40 to +85°C, 1.6 V ≤ AVDD = VDD ≤ 3.6 V, VSS = AVSS = 0 V)

(TA = +85 to +105°C, 2.4 V ≤ AVDD = VDD ≤ 3.6 V, VSS = AVSS = 0 V)

(2/4)

Parameter	Symbol	Conditions				MIN.	TYP.	MAX.	Unit	
Supply current Note 1	I _{DD1}	Operating mode	Subsystem clock operation	f _{SX} = 32.768 kHz, T _A = -40°C Note 4	Normal operation	Square wave input		3.2	6.1	μA
						Resonator connection		3.3	6.1	
				f _{SX} = 32.768 kHz, T _A = +25°C Note 4	Normal operation	Square wave input		3.4	6.1	
						Resonator connection		3.6	6.1	
				f _{SX} = 32.768 kHz, T _A = +50°C Note 4	Normal operation	Square wave input		3.5	6.7	
						Resonator connection		3.7	6.7	
				f _{SX} = 32.768 kHz, T _A = +70°C Note 4	Normal operation	Square wave input		3.7	7.5	
						Resonator connection		3.9	7.5	
				f _{SX} = 32.768 kHz, T _A = +85°C Note 4	Normal operation	Square wave input		4.0	8.9	
						Resonator connection		4.2	8.9	
				f _{SX} = 32.768 kHz, T _A = +105°C Note 4	Normal operation	Square wave input		4.5	21.0	
						Resonator connection		4.7	21.1	
				f _{IL} = 15 kHz, T _A = -40°C Note 6	Normal operation			1.8	5.9	
f _{IL} = 15 kHz, T _A = +25°C Note 6	Normal operation			1.9	5.9					
f _{IL} = 15 kHz, T _A = +85°C Note 6	Normal operation			2.3	8.7					
f _{IL} = 15 kHz, T _A = +105°C Note 6	Normal operation			3.0	20.9					

Note 1. Total current flowing into VDD, including the input leakage current flowing when the level of the input pin is fixed to VDD or VSS. The following points apply in the HS (high-speed main), LS (low-speed main), LV (low-voltage main), and LP (low-power main) modes.

- The currents in the "TYP." column do not include the operating currents of the peripheral modules.
- The currents in the "MAX." column include the operating currents of the peripheral modules, except for those flowing into the A/D converter, LVD circuit, I/O port, and on-chip pull-up/pull-down resistors, and those flowing while the data flash memory is being rewritten.

In the subsystem clock operation, the currents in both the "TYP." and "MAX." columns do not include the operating currents of the peripheral modules. However, in HALT mode, including the current flowing into the real-time clock 2.

Note 2. When the high-speed on-chip oscillator clock, middle-speed on-chip oscillator clock, low-speed on-chip oscillator clock, and sub clock are stopped.

Note 3. When the high-speed system clock, middle-speed on-chip oscillator clock, low-speed on-chip oscillator clock, and sub clock are stopped.

Note 4. When the high-speed system clock, high-speed on-chip oscillator clock, middle-speed on-chip oscillator clock, low-speed on-chip oscillator clock, and sub clock are stopped. When ultra-low-power consumption oscillation is set (AMPHS1, AMPHS0) = (1, 0).

Note 5. When the high-speed system clock, high-speed on-chip oscillator clock, sub clock, and low-speed on-chip oscillator clock are stopped.

Note 6. When the high-speed system clock, high-speed on-chip oscillator clock, middle-speed on-chip oscillator clock, and sub clock are stopped.

Note 7. When the high-speed system clock, high-speed on-chip oscillator clock, low-speed on-chip oscillator clock, and sub clock are stopped.

Remark 1. f_{MX}: High-speed system clock frequency (X1 clock oscillation frequency or external main system clock frequency)

Remark 2. f_{IH}: High-speed on-chip oscillator clock frequency (24 MHz max.)

Remark 3. f_{IM}: Middle-speed on-chip oscillator clock frequency (4 MHz max.)

Remark 4. f_{IL}: Low-speed on-chip oscillator clock frequency

Remark 5. f_{SX}: Sub clock frequency (XT1 clock oscillation frequency)

Remark 6. f_{SUB}: Subsystem clock frequency (XT1 clock oscillation frequency or low-speed on-chip oscillator clock frequency)

Remark 7. Except subsystem clock operation, temperature condition of the TYP. value is T_A = 25°C.

(TA = -40 to +85°C, 1.6 V ≤ AVDD = VDD ≤ 3.6 V, VSS = AVSS = 0 V)

(TA = +85 to +105°C, 2.4 V ≤ AVDD = VDD ≤ 3.6 V, VSS = AVSS = 0 V)

(3/4)

Parameter	Symbol	Conditions		MIN.	TYP.	MAX.	Unit				
Supply current Note 1	I _{DD2} Note 2	HALT mode	HS (high-speed main) mode	f _{IH} = 24 MHz Note 4, T _A = -40 to +85°C	V _{DD} = 3.0 V		0.37	1.83	mA		
				f _{IH} = 24 MHz Note 4, T _A = +85 to +105°C	V _{DD} = 3.0 V			2.85			
				f _{IH} = 16 MHz Note 4, T _A = -40 to +85°C	V _{DD} = 3.0 V		0.36	1.38			
				f _{IH} = 16 MHz Note 4, T _A = +85 to +105°C	V _{DD} = 3.0 V			2.08			
			LS (low-speed main) mode (MCSEL = 0)	f _{IH} = 8 MHz Note 4, T _A = -40 to +85°C	V _{DD} = 3.0 V		250	710	μA		
					V _{DD} = 2.0 V		250	710			
			LS (low-speed main) mode (MCSEL = 1)	f _{IH} = 4 MHz Note 4, T _A = -40 to +85°C	V _{DD} = 3.0 V		204	400	μA		
					V _{DD} = 2.0 V		204	400			
				f _{IM} = 4 MHz Note 7, T _A = -40 to +85°C	V _{DD} = 3.0 V		40	250			
			LV (low-voltage main) mode	f _{IH} = 3 MHz Note 4, T _A = -40 to +85°C	V _{DD} = 3.0 V		425	800	μA		
					V _{DD} = 2.0 V		425	800			
			LP (low-power main) mode (MCSEL = 1)	f _{IH} = 1 MHz Note 4, T _A = -40 to +85°C	V _{DD} = 3.0 V		192	400	μA		
					V _{DD} = 2.0 V		192	400			
				f _{IM} = 1 MHz Note 7, T _A = -40 to +85°C	V _{DD} = 3.0 V		27	100			
					V _{DD} = 2.0 V		27	100			
			HS (high-speed main) mode	f _{MX} = 20 MHz Note 3, T _A = -40 to +85°C	V _{DD} = 3.0 V	Square wave input	0.20	1.55	mA		
						Resonator connection	0.40	1.74			
					V _{DD} = 3.0 V	Square wave input		2.45			
						Resonator connection		2.57			
					V _{DD} = 3.0 V	Square wave input	0.15	0.86			
						Resonator connection	0.30	0.93			
				f _{MX} = 10 MHz Note 3, T _A = +85 to +105°C	V _{DD} = 3.0 V	Square wave input		1.28			
						Resonator connection		1.36			
				LS (low-speed main) mode (MCSEL = 0)	f _{MX} = 8 MHz Note 3, T _A = -40 to +85°C	V _{DD} = 3.0 V	Square wave input	68		550	μA
							Resonator connection	120		590	
					f _{MX} = 8 MHz Note 3, T _A = -40 to +85°C	V _{DD} = 2.0 V	Square wave input	68		550	
							Resonator connection	120		590	
			LS (low-speed main) mode (MCSEL = 1)	f _{MX} = 4 MHz Note 3, T _A = -40 to +85°C	V _{DD} = 3.0 V	Square wave input	23	128	μA		
						Resonator connection	65	200			
				f _{MX} = 1 MHz Note 3, T _A = -40 to +85°C	V _{DD} = 2.0 V	Square wave input	23	128			
						Resonator connection	65	200			
			LP (low-power main) mode (MCSEL = 1)	f _{MX} = 4 MHz Note 3, T _A = -40 to +85°C	V _{DD} = 3.0 V	Square wave input	10	64	μA		
						Resonator connection	48	150			
				f _{MX} = 1 MHz Note 3, T _A = -40 to +85°C	V _{DD} = 2.0 V	Square wave input	10	64			
						Resonator connection	48	150			
			Subsystem clock operation	f _{sx} = 32.768 kHz, T _A = -40°C Note 5	V _{DD} = 3.0 V	Square wave input	0.24	0.57	μA		
Resonator connection	0.42	0.76									
f _{sx} = 32.768 kHz, T _A = +25°C Note 5	V _{DD} = 3.0 V	Square wave input		0.30	0.57						
		Resonator connection		0.54	0.76						
f _{sx} = 32.768 kHz, T _A = +50°C Note 5	V _{DD} = 3.0 V	Square wave input		0.35	1.17						
		Resonator connection		0.60	1.36						
f _{sx} = 32.768 kHz, T _A = +70°C Note 5	V _{DD} = 3.0 V	Square wave input		0.42	1.97						
		Resonator connection		0.70	2.16						
f _{sx} = 32.768 kHz, T _A = +85°C Note 5	V _{DD} = 3.0 V	Square wave input		0.80	3.37						
		Resonator connection		0.95	3.56						
f _{sx} = 32.768 kHz, T _A = +105°C Note 5	V _{DD} = 3.0 V	Square wave input		1.80	17.10						
		Resonator connection		2.20	17.50						
f _{IL} = 15 kHz, T _A = -40°C Note 6	V _{DD} = 3.0 V	Square wave input		0.40	1.22						
		Resonator connection		0.47	1.22						
		f _{IL} = 15 kHz, T _A = +85°C Note 6	Square wave input	0.80	3.30						
			Resonator connection	2.00	17.30						

(Notes and Remarks are listed on the next page.)

- Note 1.** Total current flowing into VDD, including the input leakage current flowing when the level of the input pin is fixed to VDD or Vss. The following points apply in the HS (high-speed main), LS (low-speed main), LV (low-voltage main), and LP (low-power main) modes.
- The currents in the “TYP.” column do not include the operating currents of the peripheral modules.
 - The currents in the “MAX.” column include the operating currents of the peripheral modules, except for those flowing into the A/D converter, LVD circuit, I/O port, and on-chip pull-up/pull-down resistors, and those flowing while the data flash memory is being rewritten.
- In the subsystem clock operation, the currents in both the “TYP.” and “MAX.” columns do not include the operating currents of the peripheral modules. However, in HALT mode, including the current flowing into the real-time clock 2.
- Note 2.** When the HALT instruction is executed in the flash memory.
- Note 3.** When the high-speed on-chip oscillator clock, middle-speed on-chip oscillator clock, low-speed on-chip oscillator clock, and sub clock are stopped.
- Note 4.** When the high-speed system clock, middle-speed on-chip oscillator clock, low-speed on-chip oscillator clock, and sub clock are stopped.
- Note 5.** When the high-speed system clock, middle-speed on-chip oscillator clock, low-speed on-chip oscillator clock, and high-speed on-chip oscillator clock are stopped. When RTCLPC = 1 and ultra-low-power consumption oscillation is set (AMPHS1, AMPHS0) = (1, 0).
- Note 6.** When the high-speed on-chip oscillator clock, middle-speed on-chip oscillator clock, high-speed system clock, and sub clock are stopped.
- Note 7.** When the high-speed system clock, high-speed on-chip oscillator clock, low-speed on-chip oscillator clock, and sub clock are stopped.
- Remark 1.** fMX: High-speed system clock frequency (X1 clock oscillation frequency or external main system clock frequency)
- Remark 2.** fIH: High-speed on-chip oscillator clock frequency (24 MHz max.)
- Remark 3.** fIM: Middle-speed on-chip oscillator clock frequency (4 MHz max.)
- Remark 4.** fIL: Low-speed on-chip oscillator clock frequency
- Remark 5.** fSX: Sub clock frequency (XT1 clock oscillation frequency)
- Remark 6.** fSUB: Subsystem clock frequency (XT1 clock oscillation frequency or low-speed on-chip oscillator clock frequency)
- Remark 7.** Except subsystem clock operation, temperature condition of the TYP. value is TA = 25°C.

($T_A = -40$ to $+85^\circ\text{C}$, $1.6\text{ V} \leq AV_{DD} = V_{DD} \leq 3.6\text{ V}$, $V_{SS} = AV_{SS} = 0\text{ V}$)

($T_A = +85$ to $+105^\circ\text{C}$, $2.4\text{ V} \leq AV_{DD} = V_{DD} \leq 3.6\text{ V}$, $V_{SS} = AV_{SS} = 0\text{ V}$)

(4/4)

Parameter	Symbol	Conditions	MIN.	TYP.	MAX.	Unit	
Supply current Note 1	I _{DD3}	STOP mode Note 2	$T_A = -40^\circ\text{C}$		0.16	0.51	μA
			$T_A = +25^\circ\text{C}$		0.22	0.51	
			$T_A = +50^\circ\text{C}$		0.27	1.10	
			$T_A = +70^\circ\text{C}$		0.37	1.90	
			$T_A = +85^\circ\text{C}$		0.60	3.30	
			$T_A = +105^\circ\text{C}$		1.50	17.00	

Note 1. Total current flowing into V_{DD} , including the input leakage current flowing when the level of the input pin is fixed to V_{DD} or V_{SS} . In the STOP mode, the currents in both the "TYP." and "MAX." columns do not include the operating currents of the peripheral modules.

Note 2. For the setting of the current values when operating the subsystem clock in STOP mode, see the current values when operating the subsystem clock in HALT mode.

Peripheral Functions (Common to all products)

(TA = -40 to +85°C, 1.6 V ≤ AVDD = VDD ≤ 3.6 V, VSS = AVSS = 0 V)

(TA = +85 to +105°C, 2.4 V ≤ AVDD = VDD ≤ 3.6 V, VSS = AVSS = 0 V)

(1/2)

Parameter	Symbol	Conditions		MIN.	TYP.	MAX.	Unit
Low-speed on-chip oscillator operating current	IFIL Note 1				0.20		μA
RTC2 operating current	IRTC Notes 1, 2, 3	fsx = 32.768 kHz			0.02		μA
12-bit interval timer operating current	ITMKA Notes 1, 2, 4	fsx = 32.768 kHz			0.04		μA
8-bit interval timer operating current	ITMT Notes 1, 9	fsx = 32.768 kHz fMAIN stopped (per unit)	8-bit counter mode × 2-channel operation		0.12		μA
			16-bit counter mode operation		0.10		μA
Watchdog timer operating current	IWDT Notes 1, 2, 5	fil = 15 kHz			0.22		μA
A/D converter operating current	IADC Notes 6, 10	During maximum-speed conversion	AVDD = 3.0 V		420	720	μA
AVREF(+) current	IAREF Note 11	AVREFP = 3.0 V, ADREFP1 = 0, ADREFP0 = 1			14.0	25.0	μA
Internal reference voltage (1.45 V) current	IADREF Notes 1, 12				85.0		μA
Temperature sensor operating current	ITMPS Note 1				85.0		μA
Comparator operating current	ICMP Notes 8, 10	AVDD = 3.6 V, Regulator output voltage = 2.1 V	Comparator high-speed mode Window mode		12.5		μA
			Comparator low-speed mode Window mode		3.0		
			Comparator high-speed mode Standard mode		6.5		
			Comparator low-speed mode Standard mode		1.7		
		AVDD = 3.6 V, Regulator output voltage = 1.8 V	Comparator high-speed mode Window mode		8.0		
			Comparator low-speed mode Window mode		2.2		
			Comparator high-speed mode Standard mode		4.0		
			Comparator low-speed mode Standard mode		1.3		
Operational amplifier operating current	IAMP Notes 10, 13	Low-power consumption mode	One operational amplifier unit operates Note 14		2.5	4.0	μA
			Two operational amplifier units operate Note 14		4.5	8.0	
			Three operational amplifier units operate Note 14		6.5	11.0	
			Four operational amplifier units operate Note 14		8.5	14.0	
		High-speed mode	One operational amplifier unit operates Note 14		140	220	
			Two operational amplifier units operate Note 14		280	410	
			Three operational amplifier units operate Note 14		420	600	
			Four operational amplifier units operate Note 14		560	780	
LVD operating current	ILVD Notes 1, 7				0.10		μA

(Notes and Remarks are listed on the next page.)

- Note 1.** Current flowing to VDD.
- Note 2.** When the high-speed on-chip oscillator clock, middle-speed on-chip oscillator clock, and high-speed system clock are stopped.
- Note 3.** Current flowing only to the real-time clock 2 (RTC2) (excluding the operating current of the low-speed on-chip oscillator and the XT1 oscillator). The supply current of the RL78 microcontrollers is the sum of the values of either IDD1 or IDD2, and IRTC, when the real-time clock 2 operates in operation mode or HALT mode. When the low-speed on-chip oscillator is selected, IFIL should be added. IDD2 subsystem clock operation includes the operational current of the real-time clock 2.
- Note 4.** Current flowing only to the 12-bit interval timer (excluding the operating current of the low-speed on-chip oscillator and the XT1 oscillator). The supply current of the RL78 microcontrollers is the sum of the values of either IDD1 or IDD2, and IIT, when the 12-bit interval timer operates in operation mode or HALT mode. When the low-speed on-chip oscillator is selected, IFIL should be added.
- Note 5.** Current flowing only to the watchdog timer (including the operating current of the low-speed on-chip oscillator). The supply current of the RL78 microcontrollers is the sum of IDD1, IDD2 or IDD3 and IWDT when the watchdog timer is in operation.
- Note 6.** Current flowing only to the A/D converter. The supply current of the RL78 microcontrollers is the sum of IDD1 or IDD2 and IADC when the A/D converter operates in an operation mode or the HALT mode.
- Note 7.** Current flowing only to the LVD circuit. The supply current of the RL78 microcontrollers is the sum of IDD1, IDD2 or IDD3 and ILVD when the LVD circuit is in operation.
- Note 8.** Current flowing only to the comparator circuit. The supply current of the RL78 microcontrollers is the sum of IDD1, IDD2, or IDD3 and ICMP when the comparator circuit is in operation.
- Note 9.** Current flowing only to the 8-bit interval timer (excluding the operating current of the low-speed on-chip oscillator and the XT1 oscillator). The supply current of the RL78 microcontrollers is the sum of the values of either IDD1 or IDD2, and IIT, when the 8-bit interval timer operates in operation mode or HALT mode. When the low-speed on-chip oscillator is selected, IFIL should be added.
- Note 10.** Current flowing to AVDD.
- Note 11.** Current flowing into AVREFP.
- Note 12.** Current consumed by generating the internal reference voltage (1.45 V).
- Note 13.** Current flowing only to the operational amplifier. The current value of the RL78 microcontrollers is the sum of IDD1, IDD2, or IDD3 and IAMP when the operational amplifier is operating in operating mode, HALT mode, or STOP mode.
- Note 14.** The values include the operating current of the operational amplifier reference current circuit.
- Remark 1.** f_{IL}: Low-speed on-chip oscillator clock frequency
- Remark 2.** f_{SUB}: Subsystem clock frequency (XT1 clock oscillation frequency)
- Remark 3.** f_{CLK}: CPU/peripheral hardware clock frequency
- Remark 4.** Temperature condition of the TYP. value is T_A = 25°C.

(TA = -40 to +85°C, 1.6 V ≤ AVDD = VDD ≤ 3.6 V, VSS = AVSS = 0 V)

(TA = +85 to +105°C, 2.4 V ≤ AVDD = VDD ≤ 3.6 V, VSS = AVSS = 0 V)

(2/2)

Parameter	Symbol	Conditions		MIN.	TYP.	MAX.	Unit
Self-programming operating current	IFSP Notes 1, 3				2.0	12.20	mA
BGO current	IBGO Notes 1, 2				2.0	12.20	mA
SNOOZE operating current	ISNOZ Note 1	ADC operation AVREFF = VDD = 3.0 V TA = -40 to +85°C	The mode is performed Note 5		0.50	0.60	mA
			The A/D conversion operations are performed Note 1		0.60	0.75	mA
			The A/D conversion operations are performed Note 4		420	720	μA
		ADC operation AVREFF = VDD = 3.0 V TA = +85 to +105°C	The mode is performed Note 5		0.50	1.10	mA
			The A/D conversion operations are performed Note 1		0.60	1.34	mA
			The A/D conversion operations are performed Note 4		420	720	μA
		Simplified SPI (CSI)/UART operation	TA = -40 to +85°C		0.70	0.84	mA
			TA = +85 to +105°C		0.70	1.54	mA

Note 1. Current flowing to VDD.**Note 2.** Current flowing during programming of the data flash.**Note 3.** Current flowing during self-programming.**Note 4.** Current flowing to AVDD.**Note 5.** For shift time to the SNOOZE mode, see **23.3.3 SNOOZE mode** in the RL78/I1D User's Manual.**Remark 1.** f_{IL}: Low-speed on-chip oscillator clock frequency**Remark 2.** f_{SUB}: Subsystem clock frequency (XT1 clock oscillation frequency)**Remark 3.** f_{CLK}: CPU/peripheral hardware clock frequency**Remark 4.** Temperature condition of the TYP. value is TA = 25°C.

2.4 AC Characteristics

(TA = -40 to +85°C, 1.6 V ≤ AVDD = VDD ≤ 3.6 V, VSS = AVSS = 0 V)

(TA = +85 to +105°C, 2.4 V ≤ AVDD = VDD ≤ 3.6 V, VSS = AVSS = 0 V)

(1/2)

Items	Symbol	Conditions		MIN.	TYP.	MAX.	Unit	
Instruction cycle (minimum instruction execution time)	TCY	Main system clock (fMAIN) operation	HS (high-speed main) mode	2.7 V ≤ VDD ≤ 3.6 V	0.04167		1	μs
				2.4 V ≤ VDD < 2.7 V	0.0625		1	μs
			LS (low-speed main) mode	1.8 V ≤ VDD ≤ 3.6 V PMMC. MCSEL = 0	0.125		1	μs
				1.8 V ≤ VDD ≤ 3.6 V PMMC. MCSEL = 1	0.25		1	μs
			LP (low-power main) mode	1.8 V ≤ VDD ≤ 3.6 V	1			μs
			LV (low-voltage main) mode	1.8 V ≤ VDD ≤ 3.6 V	0.25		1	μs
		1.6 V ≤ VDD < 1.8 V		0.34		1	μs	
		Subsystem clock (fSUB) operation	fsx	1.8 V ≤ VDD ≤ 3.6 V	28.5	30.5	31.3	μs
			fil	1.8 V ≤ VDD ≤ 3.6 V		66.7		μs
		In the self- programming mode	HS (high-speed main) mode	2.7 V ≤ VDD ≤ 3.6 V	0.04167		1	μs
2.4 V ≤ VDD < 2.7 V	0.0625				1	μs		
LS (low-speed main) mode	1.8 V ≤ VDD ≤ 3.6 V		0.125		1	μs		
LV (low-voltage main) mode	1.8 V ≤ VDD ≤ 3.6 V		0.25		1	μs		
External system clock frequency	fEX	2.7 V ≤ VDD ≤ 3.6 V		1.0		20.0	MHz	
		2.4 V ≤ VDD < 2.7 V		1.0		16.0	MHz	
		1.8 V ≤ VDD < 2.4 V		1		8	MHz	
		1.6 V ≤ VDD < 1.8 V		1		4	MHz	
	fEXS			32		35	kHz	
External system clock input high-level width, low-level width	tEXH, tEXL	2.7 V ≤ VDD ≤ 3.6 V		24			ns	
		2.4 V ≤ VDD < 2.7 V		30			ns	
		1.8 V ≤ VDD < 2.4 V		60			ns	
		1.6 V ≤ VDD < 1.8 V		120			ns	
	tEXHS, tEXLS			13.7			μs	
Ti00 to Ti03 input high-level width, low-level width	tTIH, tTIL			1/fMCK + 10			ns	

Remark fMCK: Timer array unit operation clock frequency

(Operation clock to be set by the CKSmn bit of timer mode register mn (TMRmn). m: Unit number (m = 0), n: Channel number (n = 0 to 3))

(TA = -40 to +85°C, 1.6 V ≤ AVDD = VDD ≤ 3.6 V, VSS = AVSS = 0 V)

(TA = +85 to +105°C, 2.4 V ≤ AVDD = VDD ≤ 3.6 V, VSS = AVSS = 0 V)

(2/2)

Items	Symbol	Conditions	MIN.	TYP.	MAX.	Unit	
TO00 to TO03 output frequency	fro	HS (high-speed main) mode	2.7 V ≤ VDD ≤ 3.6 V			8	MHz
			2.4 V ≤ VDD < 2.7 V			4	
		LS (low-speed main) mode	1.8 V ≤ VDD ≤ 3.6 V			4	
		LP (low-power main) mode	1.8 V ≤ VDD ≤ 3.6 V			0.5	
		LV (low-voltage main) mode	1.6 V ≤ VDD ≤ 3.6 V			2	
PCLBUZ0, PCLBUZ1 output frequency	fpCL	HS (high-speed main) mode	2.7 V ≤ VDD ≤ 3.6 V			8	MHz
			2.4 V ≤ VDD < 2.7 V			4	
		LS (low-speed main) mode	1.8 V ≤ VDD ≤ 3.6 V			4	
		LP (low-power main) mode	1.8 V ≤ VDD ≤ 3.6 V			1	
		LV (low-voltage main) mode	1.8 V ≤ VDD ≤ 3.6 V			4	
			1.6 V ≤ VDD < 1.8 V			2	
Interrupt input high-level width, low-level width	tINTH, tINTL	INTP0 to INTP6	1.6 V ≤ VDD ≤ 3.6 V	1			μs
Key interrupt input low-level width	tkR	KR0 to KR3	1.8 V ≤ VDD ≤ 3.6 V	250			ns
			1.6 V ≤ VDD < 1.8 V	1			μs
RESET low-level width	trSL			10			μs

AC Timing Test Points

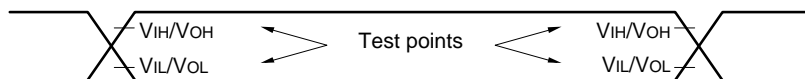

External System Clock Timing

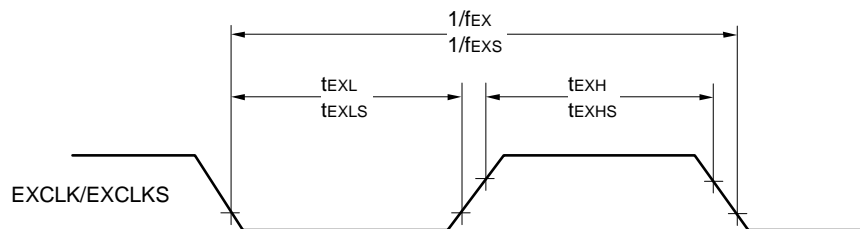

TI/TO Timing

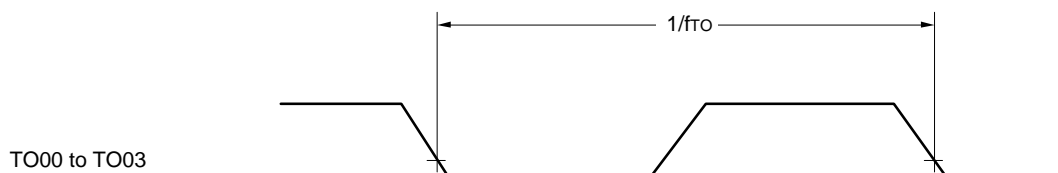
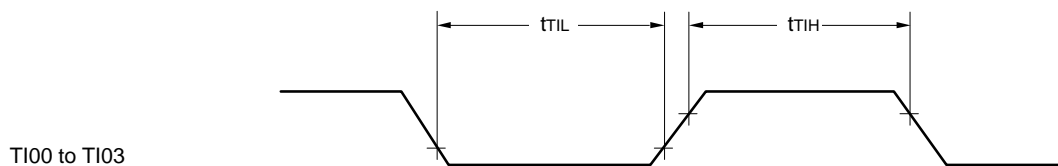

Interrupt Request Input Timing

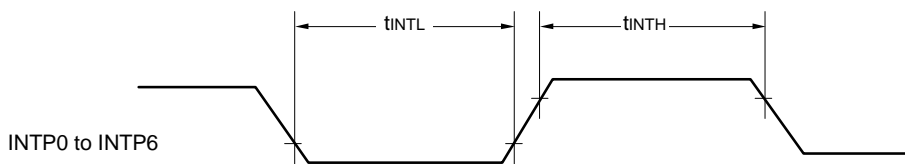

Key Interrupt Input Timing

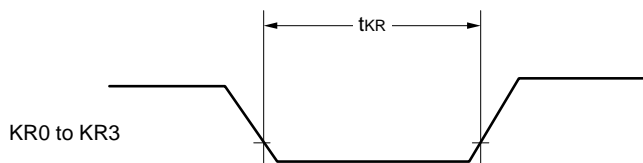

$\overline{\text{RESET}}$ Input Timing

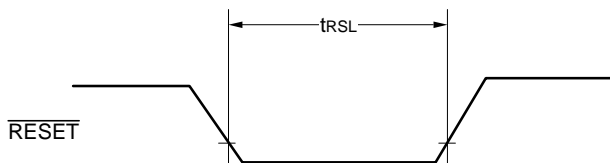

2.5 Peripheral Functions Characteristics

AC Timing Test Points

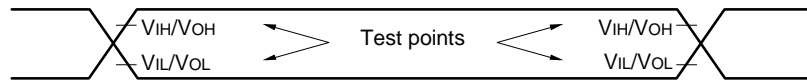

2.5.1 Serial array unit

(1) During communication at same potential (UART mode)

(TA = -40 to +85°C, 1.6 V ≤ AVDD = VDD ≤ 3.6 V, VSS = AVSS = 0 V)

Parameter	Symbol	Conditions	HS (high-speed main) Mode		LS (low-speed main) Mode		LP (Low-power main) mode		LV (low-voltage main) Mode		Unit
			MIN.	MAX.	MIN.	MAX.	MIN.	MAX.	MIN.	MAX.	
Transfer rate Note 1		2.4 V ≤ VDD ≤ 3.6 V		fMCK/6		fMCK/6		fMCK/6		fMCK/6	bps
		Theoretical value of the maximum transfer rate fMCK = fCLK Note 2		4.0		1.3		0.1		0.6	Mbps
		1.8 V ≤ VDD ≤ 3.6 V		—		fMCK/6		fMCK/6		fMCK/6	bps
		Theoretical value of the maximum transfer rate fMCK = fCLK Note 2		—		1.3		0.1		0.6	Mbps
		1.7 V ≤ VDD ≤ 3.6 V		—		—		—		fMCK/6	bps
		Theoretical value of the maximum transfer rate fMCK = fCLK Note 2		—		—		—		0.6	Mbps
1.6 V ≤ VDD ≤ 3.6 V		—		—		—		fMCK/6	bps		
	Theoretical value of the maximum transfer rate fMCK = fCLK Note 2		—		—		—		0.6	Mbps	

Note 1. Transfer rate in the SNOOZE mode is 4800 bps only.

Note 2. The maximum operating frequencies of the CPU/peripheral hardware clock (fCLK) are:

HS (high-speed main) mode:	24 MHz (2.7 V ≤ VDD ≤ 3.6 V)
	16 MHz (2.4 V ≤ VDD ≤ 3.6 V)
LS (low-speed main) mode:	8 MHz (1.8 V ≤ VDD ≤ 3.6 V)
LP (low-power main) mode:	1 MHz (1.8 V ≤ VDD ≤ 3.6 V)
LV (low-voltage main) mode:	4 MHz (1.6 V ≤ VDD ≤ 3.6 V)

Caution Select the normal input buffer for the RxDq pin and the normal output mode for the TxDq pin by using port input mode register g (PIMg) and port output mode register g (POMg).

(TA = +85 to +105°C, 2.4 V ≤ AVDD = VDD ≤ 3.6 V, VSS = AVSS = 0 V)

Parameter	Symbol	Conditions	HS (high-speed main) Mode		Unit
			MIN.	MAX.	
Transfer rate Note 1		2.4 V ≤ VDD ≤ 3.6 V		fMCK/12	bps
		Theoretical value of the maximum transfer rate fMCK = fCLK Note 2		2.0	Mbps

Note 1. Transfer rate in the SNOOZE mode is 4800 bps only.

Note 2. The maximum operating frequencies of the CPU/peripheral hardware clock (fCLK) are:

HS (high-speed main) mode:	24 MHz (2.7 V ≤ VDD ≤ 3.6 V)
	16 MHz (2.4 V ≤ VDD ≤ 3.6 V)

Caution Select the normal input buffer for the RxDq pin and the normal output mode for the TxDq pin by using port input mode register g (PIMg) and port output mode register g (POMg).

UART mode connection diagram (during communication at same potential)

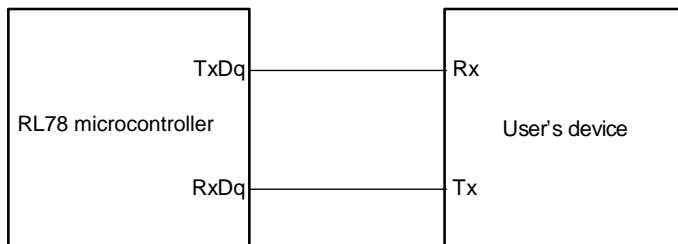

UART mode bit width (during communication at same potential) (reference)

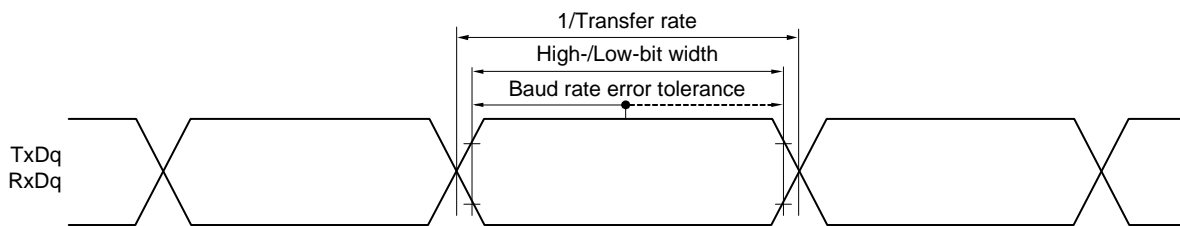

Remark 1. q: UART number (q = 0), g: PIM and POM number (g = 5)

Remark 2. f_{MC}: Serial array unit operation clock frequency

(Operation clock to be set by the CKSmn bit of serial mode register mn (SMRmn). m: Unit number, n: Channel number (mn = 00, 01))

(2) During communication at same potential (simplified SPI (CSI) mode) (master mode, SCKp... internal clock output, corresponding CSI00 only)

(TA = -40 to +85°C, 2.7 V ≤ AVDD = VDD ≤ 3.6 V, VSS = AVSS = 0 V)

Parameter	Symbol	Conditions	HS (high-speed main) Mode		LS (low-speed main) Mode		LP (Low-power main) mode		LV (low-voltage main) Mode		Unit
			MIN.	MAX.	MIN.	MAX.	MIN.	MAX.	MIN.	MAX.	
SCKp cycle time	tkCY1	tkCY1 ≥ fCLK/2	83.3		250		2000		500		ns
SCKp high-/low-level width	tkL1		tkCY1/2 - 10		tkCY1/2 - 50		tkCY1/2 - 50		tkCY1/2 - 50		ns
Slp setup time (to SCKp↑) Note 1	tSIK1		33		110		110		110		ns
Slp hold time (from SCKp↑) Note 2	tKS11		10		10		10		10		ns
Delay time from SCKp↓ to SOp output Note 3	tkSO1	C = 20 pF Note 4		10		20		20		20	ns

Note 1. When DAPmn = 0 and CKPmn = 0, or DAPmn = 1 and CKPmn = 1. The Slp setup time becomes “to SCKp↓” when DAPmn = 0 and CKPmn = 1, or DAPmn = 1 and CKPmn = 0.

Note 2. When DAPmn = 0 and CKPmn = 0, or DAPmn = 1 and CKPmn = 1. The Slp hold time becomes “from SCKp↓” when DAPmn = 0 and CKPmn = 1, or DAPmn = 1 and CKPmn = 0.

Note 3. When DAPmn = 0 and CKPmn = 0, or DAPmn = 1 and CKPmn = 1. The delay time to SOp output becomes “from SCKp↑” when DAPmn = 0 and CKPmn = 1, or DAPmn = 1 and CKPmn = 0.

Note 4. C is the load capacitance of the SCKp and SOp output lines.

Caution Select the normal input buffer for the Slp pin and the normal output mode for the SOp pin and SCKp pin by using port input mode register g (PIMg) and port output mode register g (POMg).

Remark 1. p: CSI number (p = 00), m: Unit number (m = 0), n: Channel number (n = 0), g: PIM and POM numbers (g = 5)

Remark 2. fMCK: Serial array unit operation clock frequency

(Operation clock to be set by the CKSmn bit of serial mode register mn (SMRmn). m: Unit number, n: Channel number (mn = 00))

(3) During communication at same potential (simplified SPI (CSI) mode) (master mode, SCKp... internal clock output)

(TA = -40 to +85°C, 1.6 V ≤ AVDD = VDD ≤ 3.6 V, VSS = AVSS = 0 V)

Parameter	Symbol	Conditions		HS (high-speed main) Mode		LS (low-speed main) Mode		LP (Low-power main) mode		LV (low-voltage main) Mode		Unit
				MIN.	MAX.	MIN.	MAX.	MIN.	MAX.	MIN.	MAX.	
SCKp cycle time	tkCY1	tkCY1 ≥ fCLK/4	2.7 V ≤ VDD ≤ 3.6 V	167		500		4000		1000		ns
			2.4 V ≤ VDD ≤ 3.6 V	250								
			1.8 V ≤ VDD ≤ 3.6 V	—								
			1.7 V ≤ VDD ≤ 3.6 V	—								
			1.6 V ≤ VDD ≤ 3.6 V	—								
SCKp high-/low-level width	tkH1, tkL1	2.7 V ≤ VDD ≤ 3.6 V	tkCY1/2 - 18		tkCY1/2 - 50		tkCY1/2 - 50		tkCY1/2 - 50		ns	
			2.4 V ≤ VDD ≤ 3.6 V	tkCY1/2 - 38								
			1.8 V ≤ VDD ≤ 3.6 V	—								
			1.7 V ≤ VDD ≤ 3.6 V	—								
			1.6 V ≤ VDD ≤ 3.6 V	—								
Slp setup time (to SCKp↑) Note 1	tsIK1	2.7 V ≤ VDD ≤ 3.6 V	58		110		110		110		ns	
			2.4 V ≤ VDD ≤ 3.6 V	75								
			1.8 V ≤ VDD ≤ 3.6 V	—								
			1.7 V ≤ VDD ≤ 3.6 V	—								
			1.6 V ≤ VDD ≤ 3.6 V	—								
Slp hold time (from SCKp↑) Note 2	tkSI1	2.4 V ≤ VDD ≤ 3.6 V	19		19		19		19		ns	
			1.8 V ≤ VDD ≤ 3.6 V	—								
			1.6 V ≤ VDD ≤ 3.6 V	—								
Delay time from SCKp↓ to SOp output Note 3	tkSO1	C = 30 pF Note 4	2.4 V ≤ VDD ≤ 3.6 V	33.4		33.4		33.4		33.4	ns	
			1.8 V ≤ VDD ≤ 3.6 V	—								
			1.6 V ≤ VDD ≤ 3.6 V	—								

Note 1. When DAPmn = 0 and CKPmn = 0, or DAPmn = 1 and CKPmn = 1. The Slp setup time becomes “to SCKp↓” when DAPmn = 0 and CKPmn = 1, or DAPmn = 1 and CKPmn = 0.

Note 2. When DAPmn = 0 and CKPmn = 0, or DAPmn = 1 and CKPmn = 1. The Slp hold time becomes “from SCKp↓” when DAPmn = 0 and CKPmn = 1, or DAPmn = 1 and CKPmn = 0.

Note 3. When DAPmn = 0 and CKPmn = 0, or DAPmn = 1 and CKPmn = 1. The delay time to SOp output becomes “from SCKp↑” when DAPmn = 0 and CKPmn = 1, or DAPmn = 1 and CKPmn = 0.

Note 4. C is the load capacitance of the SCKp and SOp output lines.

Caution Select the normal input buffer for the Slp pin and the normal output mode for the SOp pin and SCKp pin by using port input mode register g (PIMg) and port output mode register g (POMg).

Remark 1. p: CSI number (p = 00), m: Unit number (m = 0), n: Channel number (n = 0), g: PIM and POM numbers (g = 5)

Remark 2. fMCK: Serial array unit operation clock frequency
(Operation clock to be set by the CKSmn bit of serial mode register mn (SMRmn). m: Unit number, n: Channel number (mn = 00, 01))

(3) During communication at same potential (simplified SPI (CSI) mode) (master mode, SCKp... internal clock output)**(TA = +85 to +105°C, 2.7 V ≤ AVDD = VDD ≤ 3.6 V, VSS = AVSS = 0 V)**

Parameter	Symbol	Conditions	HS (high-speed main) Mode		Unit	
			MIN.	MAX.		
SCKp cycle time	tkCY1	tkCY1 ≥ fCLK/4	2.7 V ≤ VDD ≤ 3.6 V	250		ns
			2.4 V ≤ VDD ≤ 3.6 V	500		ns
SCKp high-/low-level width	tkH1, tkL1	2.7 V ≤ VDD ≤ 3.6 V	tkCY1/2 - 36			ns
		2.4 V ≤ VDD ≤ 3.6 V	tkCY1/2 - 76			ns
Slp setup time (to SCKp↑) Note 1	tSIK1	2.7 V ≤ VDD ≤ 3.6 V	66			ns
		2.4 V ≤ VDD ≤ 3.6 V	133			ns
Slp hold time (from SCKp↑) Note 2	tKSI1		38			ns
Delay time from SCKp↓ to SOp output Note 3	tKSO1	C = 30 pF Note 4		50		ns

Note 1. When DAPmn = 0 and CKPmn = 0, or DAPmn = 1 and CKPmn = 1. The Slp setup time becomes “to SCKp↓” when DAPmn = 0 and CKPmn = 1, or DAPmn = 1 and CKPmn = 0.

Note 2. When DAPmn = 0 and CKPmn = 0, or DAPmn = 1 and CKPmn = 1. The Slp hold time becomes “from SCKp↓” when DAPmn = 0 and CKPmn = 1, or DAPmn = 1 and CKPmn = 0.

Note 3. When DAPmn = 0 and CKPmn = 0, or DAPmn = 1 and CKPmn = 1. The delay time to SOp output becomes “from SCKp↑” when DAPmn = 0 and CKPmn = 1, or DAPmn = 1 and CKPmn = 0.

Note 4. C is the load capacitance of the SCKp and SOp output lines.

Caution Select the normal input buffer for the Slp pin and the normal output mode for the SOp pin and SCKp pin by using port input mode register g (PIMg) and port output mode register g (POMg).

Remark 1. p: CSI number (p = 00), m: Unit number (m = 0), n: Channel number (n = 0), g: PIM and POM numbers (g = 5)

Remark 2. fMCK: Serial array unit operation clock frequency
(Operation clock to be set by the CKSmn bit of serial mode register mn (SMRmn). m: Unit number, n: Channel number (mn = 00, 01))

(4) During communication at same potential (simplified SPI (CSI) mode) (slave mode, SCKp... external clock input)

(TA = -40 to +85°C, 1.6 V ≤ AVDD = VDD ≤ 3.6 V, VSS = AVSS = 0 V) (1/2)

Parameter	Symbol	Conditions		HS (high-speed main) Mode		LS (low-speed main) Mode		LP (Low-power main) mode		LV (low-voltage main) Mode		Unit
				MIN.	MAX.	MIN.	MAX.	MIN.	MAX.	MIN.	MAX.	
SCKp cycle time Note 5	tkcy2	2.7 V ≤ VDD ≤ 3.6 V	fMCK > 16 MHz	8/fMCK	—	—	—	—	—	—	ns	
			fMCK ≤ 16 MHz	6/fMCK	6/fMCK	6/fMCK	6/fMCK	6/fMCK				
		2.4 V ≤ VDD ≤ 3.6 V		6/fMCK and 500	6/fMCK	6/fMCK	6/fMCK	6/fMCK	6/fMCK			
		1.8 V ≤ VDD ≤ 3.6 V		—	6/fMCK	6/fMCK	6/fMCK	6/fMCK				
		1.7 V ≤ VDD ≤ 3.6 V		—	—	—	—	—				
		1.6 V ≤ VDD ≤ 3.6 V		—	—	—	—	—				
SCKp high-/low-level width	tkH2, tkL2	2.7 V ≤ VDD ≤ 3.6 V		tkcy2/2 - 8	tkcy2/2 - 8	tkcy2/2 - 8	tkcy2/2 - 8	tkcy2/2 - 8	tkcy2/2 - 8	ns		
		2.4 V ≤ VDD ≤ 3.6 V		tkcy2/2 - 18	tkcy2/2 - 18	tkcy2/2 - 18	tkcy2/2 - 18	tkcy2/2 - 18				
		1.8 V ≤ VDD ≤ 3.6 V		—	—	—	—	—				
		1.7 V ≤ VDD ≤ 3.6 V		—	—	—	—	tkcy2/2 - 66				
		1.6 V ≤ VDD ≤ 3.6 V		—	—	—	—	—				
Slp setup time (to SCKp↑) Note 1	tsik2	2.7 V ≤ VDD ≤ 3.6 V		1/fMCK + 20	1/fMCK + 30	1/fMCK + 30	1/fMCK + 30	1/fMCK + 30	ns			
		2.4 V ≤ VDD ≤ 3.6 V		1/fMCK + 30	—	—	—	—				
		1.8 V ≤ VDD ≤ 3.6 V		—	—	—	—	—				
		1.7 V ≤ VDD ≤ 3.6 V		—	—	—	—	1/fMCK + 40				
		1.6 V ≤ VDD ≤ 3.6 V		—	—	—	—	—				
Slp hold time (from SCKp↓) Note 2	tksl2	2.4 V ≤ VDD ≤ 3.6 V		1/fMCK + 31	1/fMCK + 31	1/fMCK + 31	1/fMCK + 31	1/fMCK + 31	ns			
		1.8 V ≤ VDD ≤ 3.6 V		—	—	—	—	—				
		1.7 V ≤ VDD ≤ 3.6 V		—	—	—	—	1/fMCK + 250				
		1.6 V ≤ VDD ≤ 3.6 V		—	—	—	—	—				
Delay time from SCKp↓ to SOp output Note 3	tkso2	C = 30 pF Note 4	2.7 V ≤ VDD ≤ 3.6 V	2/fMCK + 44	2/fMCK + 110	2/fMCK + 110	2/fMCK + 110	2/fMCK + 110	ns			
			2.4 V ≤ VDD ≤ 3.6 V	2/fMCK + 75	—	—	—	—				
			1.8 V ≤ VDD ≤ 3.6 V	—	—	—	—	—				
			1.7 V ≤ VDD ≤ 3.6 V	—	—	—	—	2/fMCK + 220				
			1.6 V ≤ VDD ≤ 3.6 V	—	—	—	—	—				

- Note 1.** When DAPmn = 0 and CKPmn = 0, or DAPmn = 1 and CKPmn = 1. The Slp setup time becomes “to SCKp↓” when DAPmn = 0 and CKPmn = 1, or DAPmn = 1 and CKPmn = 0.
- Note 2.** When DAPmn = 0 and CKPmn = 0, or DAPmn = 1 and CKPmn = 1. The Slp hold time becomes “from SCKp↓” when DAPmn = 0 and CKPmn = 1, or DAPmn = 1 and CKPmn = 0.
- Note 3.** When DAPmn = 0 and CKPmn = 0, or DAPmn = 1 and CKPmn = 1. The delay time to SOp output becomes “from SCKp↑” when DAPmn = 0 and CKPmn = 1, or DAPmn = 1 and CKPmn = 0.
- Note 4.** C is the load capacitance of the SOp output lines.
- Note 5.** The maximum transfer rate when using the SNOOZE mode is 1 Mbps.

Caution Select the normal input buffer for the Slp pin and the normal output mode for the SOp pin by using port input mode register g (PIMg) and port output mode register g (POMg).

- Remark 1.** p: CSI number (p = 00), m: Unit number (m = 0), n: Channel number (n = 0), g: PIM and POM numbers (g = 5)
- Remark 2.** fMCK: Serial array unit operation clock frequency
(Operation clock to be set by the CKSmn bit of serial mode register mn (SMRmn). m: Unit number, n: Channel number (mn = 00, 01))

(4) During communication at same potential (simplified SPI (CSI) mode) (slave mode, SCKp... external clock input)

(TA = -40 to +85°C, 1.6 V ≤ AVDD = VDD ≤ 3.6 V, VSS = AVSS = 0 V) (2/2)

Parameter	Symbol	Conditions	HS (high-speed main) Mode		LS (low-speed main) Mode		LP (Low-power main) mode		LV (low-voltage main) Mode		Unit	
			MIN.	MAX.	MIN.	MAX.	MIN.	MAX.	MIN.	MAX.		
SSi00 setup time	tssik	DAPmn = 0	2.7 V ≤ VDD ≤ 3.6 V	120		120		120		120		ns
			2.4 V ≤ VDD < 2.7 V	200		200		200		200		
			1.8 V ≤ VDD < 2.4 V	—		—		—		—		
			1.6 V ≤ VDD < 1.8 V	—		—		—		400		
		DAPmn = 1	2.7 V ≤ VDD ≤ 3.6 V	1/fMCK + 120		1/fMCK + 120		1/fMCK + 120		1/fMCK + 120		ns
			2.4 V ≤ VDD < 2.7 V	1/fMCK + 200		1/fMCK + 200		1/fMCK + 200		1/fMCK + 200		
			1.8 V ≤ VDD < 2.4 V	—		—		—		—		
			1.6 V ≤ VDD < 1.8 V	—		—		—		1/fMCK + 400		
SSi00 hold time	tkssi	DAPmn = 0	2.7 V ≤ VDD ≤ 3.6 V	1/fMCK + 120		1/fMCK + 120		1/fMCK + 120		1/fMCK + 120		ns
			2.4 V ≤ VDD < 2.7 V	1/fMCK + 200		1/fMCK + 200		1/fMCK + 200		1/fMCK + 200		
			1.8 V ≤ VDD < 2.4 V	—		—		—		—		
			1.6 V ≤ VDD < 1.8 V	—		—		—		1/fMCK + 400		
		DAPmn = 1	2.7 V ≤ VDD ≤ 3.6 V	120		120		120		120		ns
			2.4 V ≤ VDD < 2.7 V	200		200		200		200		
			1.8 V ≤ VDD < 2.4 V	—		—		—		—		
			1.6 V ≤ VDD < 1.8 V	—		—		—		400		

Caution Select the normal input buffer for the Slp pin and SCKp pin and the normal output mode for the SOp pin by using port input mode register g (PIMg) and port output mode register g (POMg).

Remark p: CSI number (p = 00), m: Unit number (m = 0), n: Channel number (n = 0), g: PIM and POM numbers (g = 5)

Simplified SPI (CSI) mode connection diagram (during communication at same potential)

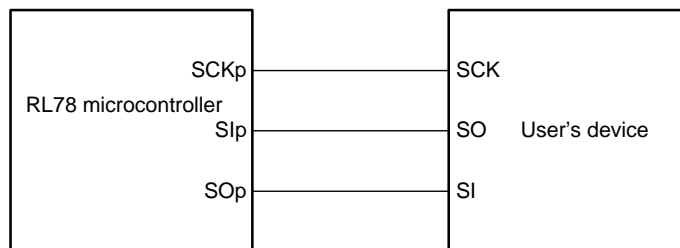

**Simplified SPI (CSI) mode connection diagram (during communication at same potential)
(Slave Transmission of slave select input function (CSI00))**

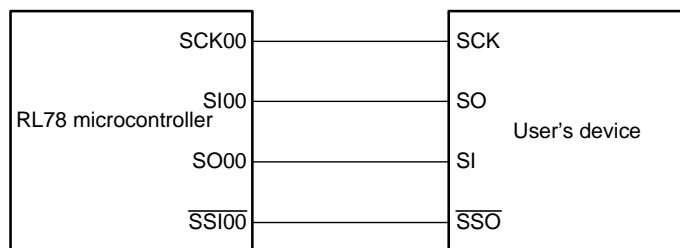

Remark 1. p: CSI number (p = 00, 01)

Remark 2. m: Unit number, n: Channel number (mn = 00, 01)

(4) During communication at same potential (simplified SPI (CSI) mode) (slave mode, SCKp... external clock input)**(TA = +85 to +105°C, 2.4 V ≤ AVDD = VDD ≤ 3.6 V, VSS = AVSS = 0 V)****(1/2)**

Parameter	Symbol	Conditions	HS (high-speed main) Mode		Unit
			MIN.	MAX.	
SCKp cycle time Note 5	tkCY2	2.7 V ≤ VDD < 3.6 V	fMCK > 16 MHz	16/fMCK	ns
			fMCK ≤ 16 MHz	12/fMCK	ns
		2.4 V ≤ VDD < 2.7 V	12/fMCK and 1000	ns	
SCKp high-/low-level width	tkH2, tkL2	2.7 V ≤ VDD ≤ 3.6 V	tkCY2/2 - 16		ns
		2.4 V ≤ VDD < 2.7 V	tkCY2/2 - 36		ns
Slp setup time (to SCKp↑) Note 1	tsIK2	2.7 V ≤ VDD ≤ 3.6 V	1/fMCK + 40		ns
		2.4 V ≤ VDD < 2.7 V	1/fMCK + 60		ns
Slp hold time (from SCKp↑) Note 2	tkSI2		1/fMCK + 62		ns
Delay time from SCKp↓ to SOp output Note 3	tkSO2	C = 30 pF Note 4	2.7 V ≤ VDD ≤ 3.6 V	2/fMCK + 66	ns
			2.4 V ≤ VDD < 2.7 V	2/fMCK + 113	ns

Note 1. When DAPmn = 0 and CKPmn = 0, or DAPmn = 1 and CKPmn = 1. The Slp setup time becomes “to SCKp↓” when DAPmn = 0 and CKPmn = 1, or DAPmn = 1 and CKPmn = 0.

Note 2. When DAPmn = 0 and CKPmn = 0, or DAPmn = 1 and CKPmn = 1. The Slp hold time becomes “from SCKp↓” when DAPmn = 0 and CKPmn = 1, or DAPmn = 1 and CKPmn = 0.

Note 3. When DAPmn = 0 and CKPmn = 0, or DAPmn = 1 and CKPmn = 1. The delay time to SOp output becomes “from SCKp↑” when DAPmn = 0 and CKPmn = 1, or DAPmn = 1 and CKPmn = 0.

Note 4. C is the load capacitance of the SOp output lines.

Note 5. The maximum transfer rate when using the SNOOZE mode is 1 Mbps.

Caution Select the normal input buffer for the Slp pin and the normal output mode for the SOp pin by using port input mode register g (PIMg) and port output mode register g (POMg).

Remark 1. p: CSI number (p = 00), m: Unit number (m = 0), n: Channel number (n = 0), g: PIM and POM numbers (g = 5)

Remark 2. fMCK: Serial array unit operation clock frequency

(Operation clock to be set by the CKSmn bit of serial mode register mn (SMRmn). m: Unit number, n: Channel number (mn = 00, 01))

(4) During communication at same potential (simplified SPI (CSI) mode) (slave mode, SCKp... external clock input)

(TA = +85 to +105°C, 2.4 V ≤ AVDD = VDD ≤ 3.6 V, VSS = AVSS = 0 V)

(2/2)

Parameter	Symbol	Conditions		HS (high-speed main) Mode		Unit
				MIN.	MAX.	
SSi00 setup time	tSSiK	DAPmn = 0	2.7 V ≤ VDD ≤ 3.6 V	240		ns
			2.4 V ≤ VDD < 2.7 V	400		ns
		DAPmn = 1	2.7 V ≤ VDD ≤ 3.6 V	1/fMCK + 240		ns
			2.4 V ≤ VDD < 2.7 V	1/fMCK + 400		ns
SSi00 hold time	tKSSi	DAPmn = 0	2.7 V ≤ VDD ≤ 3.6 V	1/fMCK + 240		ns
			2.4 V ≤ VDD < 2.7 V	1/fMCK + 400		ns
		DAPmn = 1	2.7 V ≤ VDD ≤ 3.6 V	240		ns
			2.4 V ≤ VDD < 2.7 V	400		ns

Caution Select the normal input buffer for the Slp pin and SCKp pin and the normal output mode for the SOp pin by using port input mode register g (PIMg) and port output mode register g (POMg).

Remark p: CSI number (p = 00), m: Unit number (m = 0), n: Channel number (n = 0), g: PIM and POM numbers (g = 5)

Simplified SPI (CSI) mode connection diagram (during communication at same potential)

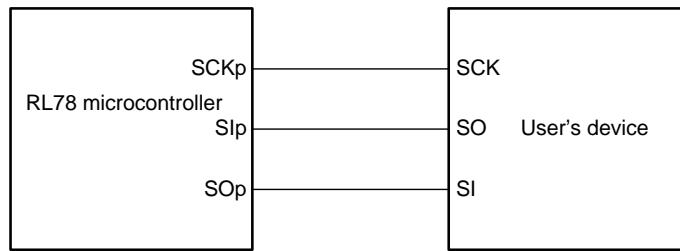

**Simplified SPI (CSI) mode connection diagram (during communication at same potential)
(Slave Transmission of slave select input function (CSI00))**

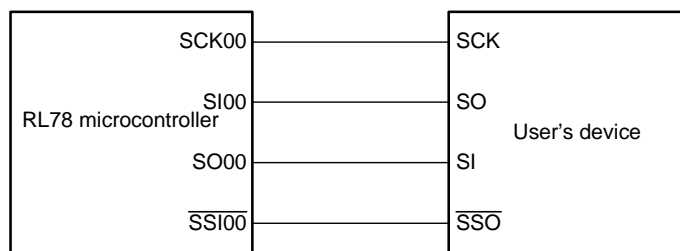

Remark 1. p: CSI number (p = 00, 01)

Remark 2. m: Unit number, n: Channel number (mn = 00, 01)

Simplified SPI (CSI) mode serial transfer timing (during communication at same potential)
(When DAPmn = 0 and CKPmn = 0, or DAPmn = 1 and CKPmn = 1.)

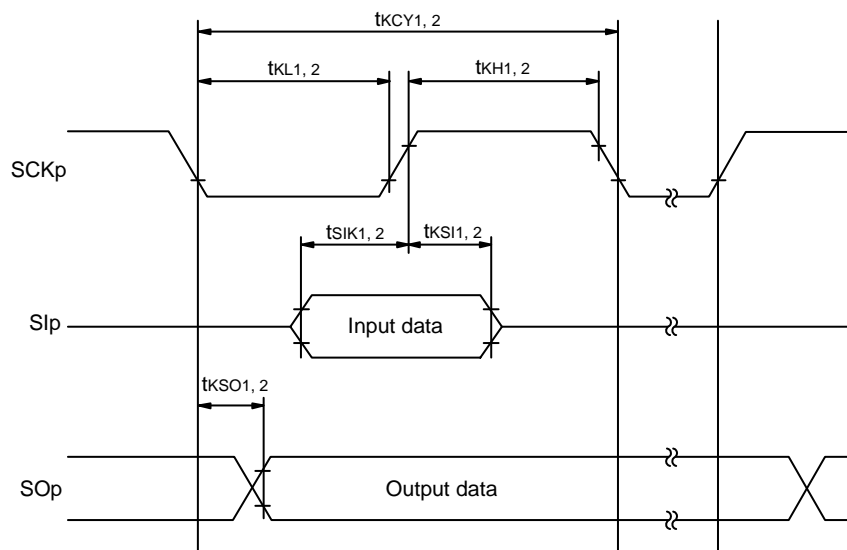

Simplified SPI (CSI) mode serial transfer timing (during communication at same potential)
(When DAPmn = 0 and CKPmn = 1, or DAPmn = 1 and CKPmn = 0.)

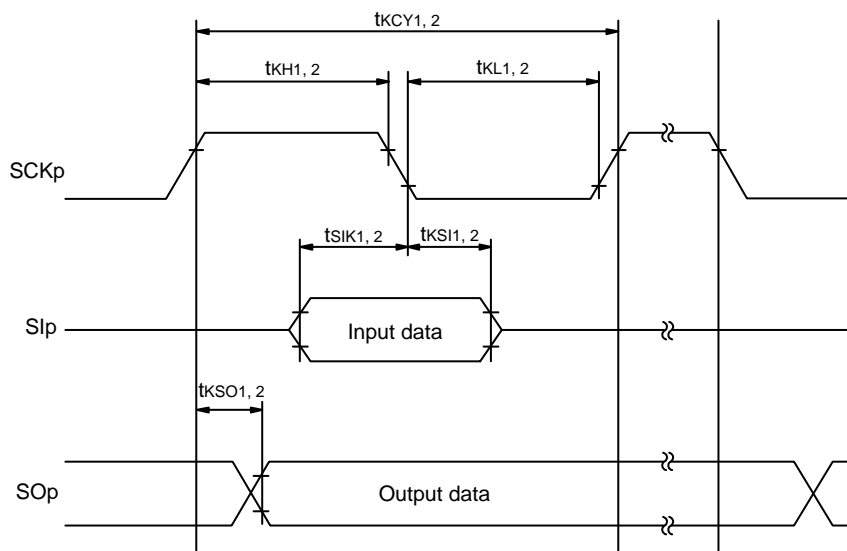

Remark 1. p: CSI number (p = 00, 01)

Remark 2. m: Unit number, n: Channel number (mn = 00, 01)

(5) During communication at same potential (simplified I²C mode)

(TA = -40 to +85°C, 1.6 V ≤ AVDD = VDD ≤ 3.6 V, VSS = AVSS = 0 V)

Parameter	Symbol	Conditions	HS (high-speed main) Mode		LS (low-speed main) Mode		LP (Low-power main) mode		LV (low-voltage main) Mode		Unit
			MIN.	MAX.	MIN.	MAX.	MIN.	MAX.	MIN.	MAX.	
SCLr clock frequency	f _{SCL}	2.7 V ≤ V _{DD} ≤ 3.6 V, C _b = 50 pF, R _b = 2.7 kΩ		1000 Note 1		400 Note 1		250 Note 1		400 Note 1	kHz
		1.8 V ≤ V _{DD} ≤ 3.6 V, C _b = 100 pF, R _b = 3 kΩ		—							
		1.8 V ≤ V _{DD} < 2.7 V, C _b = 100 pF, R _b = 5 kΩ		—		300 Note 1		250 Note 1		300 Note 1	
		1.7 V ≤ V _{DD} < 1.8 V, C _b = 100 pF, R _b = 5 kΩ		—		—		—		250 Note 1	
		1.6 V ≤ V _{DD} < 1.8 V, C _b = 100 pF, R _b = 5 kΩ		—		—		—		—	
Hold time when SCLr = "L"	t _{LOW}	2.7 V ≤ V _{DD} ≤ 3.6 V, C _b = 50 pF, R _b = 2.7 kΩ	475		1150		1150		1150		ns
		1.8 V ≤ V _{DD} ≤ 3.6 V, C _b = 100 pF, R _b = 3 kΩ	—								
		1.8 V ≤ V _{DD} < 2.7 V, C _b = 100 pF, R _b = 5 kΩ	—		1550		1550		1550		
		1.7 V ≤ V _{DD} < 1.8 V, C _b = 100 pF, R _b = 5 kΩ	—		—		—		1850		
		1.6 V ≤ V _{DD} < 1.8 V, C _b = 100 pF, R _b = 5 kΩ	—		—		—		—		
Hold time when SCLr = "H"	t _{HIGH}	2.7 V ≤ V _{DD} ≤ 3.6 V, C _b = 50 pF, R _b = 2.7 kΩ	475		1150		1150		1150		ns
		1.8 V ≤ V _{DD} ≤ 3.6 V, C _b = 100 pF, R _b = 3 kΩ	—								
		1.8 V ≤ V _{DD} < 2.7 V, C _b = 100 pF, R _b = 5 kΩ	—		1550		1550		1550		
		1.7 V ≤ V _{DD} < 1.8 V, C _b = 100 pF, R _b = 5 kΩ	—		—		—		1850		
		1.6 V ≤ V _{DD} < 1.8 V, C _b = 100 pF, R _b = 5 kΩ	—		—		—		—		
Data setup time (reception)	t _{SETUP: DAT}	2.7 V ≤ V _{DD} ≤ 3.6 V, C _b = 50 pF, R _b = 2.7 kΩ	1/f _{MCK} + 85 Note 2		1/f _{MCK} + 145 Note 2		1/f _{MCK} + 145 Note 2		1/f _{MCK} + 145 Note 2		ns
		1.8 V ≤ V _{DD} ≤ 3.6 V, C _b = 100 pF, R _b = 3 kΩ	—								
		1.8 V ≤ V _{DD} < 2.7 V, C _b = 100 pF, R _b = 5 kΩ	—		1/f _{MCK} + 230 Note 2		1/f _{MCK} + 230 Note 2		1/f _{MCK} + 230 Note 2		
		1.7 V ≤ V _{DD} < 1.8 V, C _b = 100 pF, R _b = 5 kΩ	—		—		—		1/f _{MCK} + 290 Note 2		
		1.6 V ≤ V _{DD} < 1.8 V, C _b = 100 pF, R _b = 5 kΩ	—		—		—		—		
Data hold time (transmission)	t _{HOLD: DAT}	2.7 V ≤ V _{DD} ≤ 3.6 V, C _b = 50 pF, R _b = 2.7 kΩ	0	305	0	305	0	305	0	305	ns
		1.8 V ≤ V _{DD} ≤ 3.6 V, C _b = 100 pF, R _b = 3 kΩ	—	—		355		355		355	
		1.8 V ≤ V _{DD} < 2.7 V, C _b = 100 pF, R _b = 5 kΩ	—	—							
		1.7 V ≤ V _{DD} < 1.8 V, C _b = 100 pF, R _b = 5 kΩ	—	—						405	
		1.6 V ≤ V _{DD} < 1.8 V, C _b = 100 pF, R _b = 5 kΩ	—	—							

(Notes and Caution are listed on the next page.)

Note 1. The value must also be equal to or less than $f_{MCK}/4$.

Note 2. Set the f_{MCK} value to keep the hold time of $SCLr = "L"$ and $SCLr = "H"$.

Caution Select the normal input buffer and the N-ch open drain output (V_{DD} tolerance) mode for the $SDAr$ pin and the normal output mode for the $SCLr$ pin by using port input mode register g (PIMg) and port output mode register h (POMh).

(5) During communication at same potential (simplified I²C mode)**(TA = +85 to +105°C, 2.4 V ≤ AVDD = VDD ≤ 3.6 V, VSS = AVSS = 0 V)**

Parameter	Symbol	Conditions	HS (high-speed main) Mode		Unit
			MIN.	MAX.	
SCLr clock frequency	f _{SCL}	2.7 V ≤ V _{DD} ≤ 3.6 V, C _b = 50 pF, R _b = 2.7 kΩ		400 Note 1	kHz
		2.4 V ≤ V _{DD} ≤ 3.6 V, C _b = 100 pF, R _b = 3 kΩ		100 Note 1	kHz
Hold time when SCLr = "L"	t _{LOW}	2.7 V ≤ V _{DD} ≤ 3.6 V, C _b = 50 pF, R _b = 2.7 kΩ	1200		ns
		2.4 V ≤ V _{DD} ≤ 3.6 V, C _b = 100 pF, R _b = 3 kΩ	4600		ns
Hold time when SCLr = "H"	t _{HIGH}	2.7 V ≤ V _{DD} ≤ 3.6 V, C _b = 50 pF, R _b = 2.7 kΩ	1200		ns
		2.4 V ≤ V _{DD} ≤ 3.6 V, C _b = 100 pF, R _b = 3 kΩ	4600		ns
Data setup time (reception)	t _{SU: DAT}	2.7 V ≤ V _{DD} ≤ 3.6 V, C _b = 50 pF, R _b = 2.7 kΩ	1/f _{MCK} + 220 Note 2		ns
		2.4 V ≤ V _{DD} ≤ 3.6 V, C _b = 100 pF, R _b = 3 kΩ	1/f _{MCK} + 580 Note 2		ns
Data hold time (transmission)	t _{HD: DAT}	2.7 V ≤ V _{DD} ≤ 3.6 V, C _b = 50 pF, R _b = 2.7 kΩ	0	770	ns
		2.4 V ≤ V _{DD} ≤ 3.6 V, C _b = 100 pF, R _b = 3 kΩ	0	1420	ns

Note 1. The value must also be equal to or less than f_{MCK}/4.

Note 2. Set the f_{MCK} value to keep the hold time of SCLr = "L" and SCLr = "H".

Caution Select the normal input buffer and the N-ch open drain output (V_{DD} tolerance) mode for the SDAr pin and the normal output mode for the SCLr pin by using port input mode register g (PIMg) and port output mode register h (POMh).

Simplified I²C mode connection diagram (during communication at same potential)

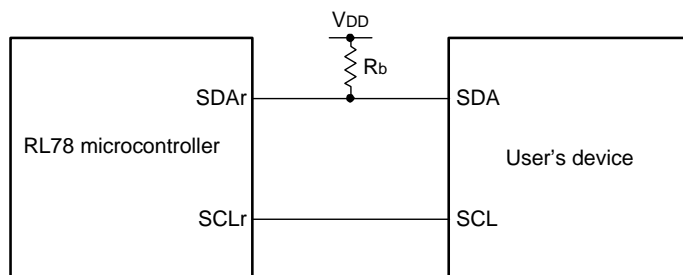

Simplified I²C mode serial transfer timing (during communication at same potential)

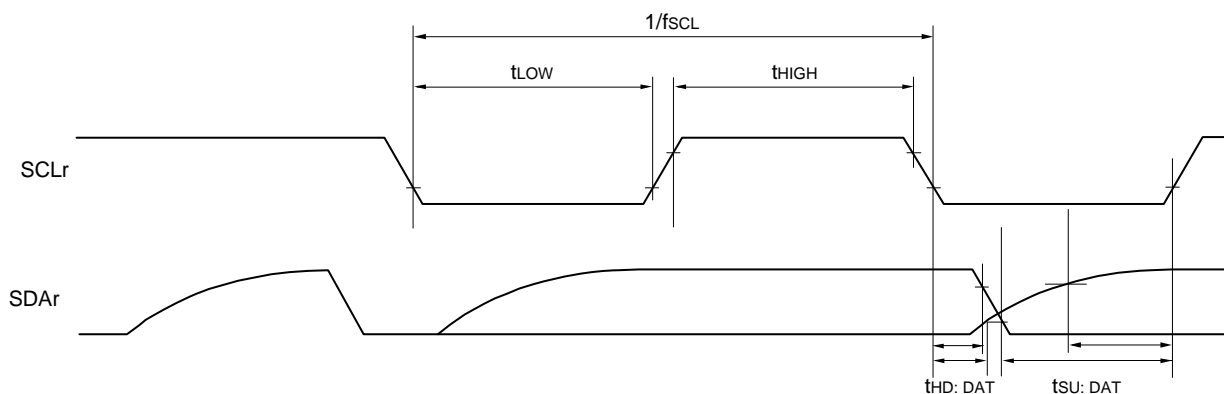

- Remark 1.** $R_b[\Omega]$: Communication line (SDAr) pull-up resistance, $C_b[F]$: Communication line (SDAr, SCLr) load capacitance
- Remark 2.** r: IIC number (r = 00, 01), g: PIM number (g = 5), h: POM number (h = 5)
- Remark 3.** f_{mck} : Serial array unit operation clock frequency
 (Operation clock to be set by the CKSmn bit of serial mode register mn (SMRmn). m: Unit number (m = 0), n: Channel number (n = 0, 1), mn = 00, 01)

(6) Communication at different potential (1.8 V, 2.5 V) (UART mode) (dedicated baud rate generator output)

(TA = -40 to +85°C, 1.8 V ≤ AVDD = VDD ≤ 3.6 V, VSS = AVSS = 0 V)

(1/2)

Parameter	Symbol	Conditions	HS (high-speed main) Mode		LS (low-speed main) Mode		LP (Low-power main) mode		LV (low-voltage main) Mode		Unit	
			MIN.	MAX.	MIN.	MAX.	MIN.	MAX.	MIN.	MAX.		
Transfer rate Notes 1, 2		reception	2.7 V ≤ VDD ≤ 3.6 V, 2.3 V ≤ Vb ≤ 2.7 V		fMCK/6 Note 1		fMCK/6 Note 1		fMCK/6 Note 1		fMCK/6 Note 1	bps
					4.0		1.3		0.1		0.6	Mbps
			Theoretical value of the maximum transfer rate fMCK = fCLK Note 3		4.0		1.3		0.1		0.6	Mbps
				1.8 V ≤ VDD < 3.3 V, 1.6 V ≤ Vb ≤ 2.0 V		fMCK/6 Notes 1, 2		fMCK/6 Notes 1, 2		fMCK/6 Notes 1, 2		fMCK/6 Notes 1, 2
		Theoretical value of the maximum transfer rate fMCK = fCLK Note 3		4.0		1.3		0.1		0.6	Mbps	

Note 1. Transfer rate in the SNOOZE mode is 4,800 bps only.

Note 2. Use it with VDD ≥ Vb.

Note 3. The maximum operating frequencies of the CPU/peripheral hardware clock (fCLK) are:

HS (high-speed main) mode: 24 MHz (2.7 V ≤ VDD ≤ 3.6 V)
16 MHz (2.4 V ≤ VDD ≤ 3.6 V)

LS (low-speed main) mode: 8 MHz (1.8 V ≤ VDD ≤ 3.6 V)

LP (low-power main) mode: 1 MHz (1.8 V ≤ VDD ≤ 3.6 V)

LV (low-voltage main) mode: 4 MHz (1.6 V ≤ VDD ≤ 3.6 V)

Caution Select the TTL input buffer for the RxDq pin and the N-ch open drain output (VDD tolerance) mode for the TxDq pin by using port input mode register g (PIMg) and port output mode register g (POMg). For VIH and VIL, see the DC characteristics with TTL input buffer selected.

Remark 1. Vb[V]: Communication line voltage

Remark 2. q: UART number (q = 0), g: PIM and POM number (g = 5)

Remark 3. fMCK: Serial array unit operation clock frequency

(Operation clock to be set by the CKSmn bit of serial mode register mn (SMRmn). m: Unit number,

n: Channel number (mn = 00, 01)

(6) Communication at different potential (1.8 V, 2.5 V) (UART mode) (dedicated baud rate generator output)

(TA = -40 to +85°C, 1.8 V ≤ AVDD = VDD ≤ 3.6 V, VSS = AVSS = 0 V)

(2/2)

Parameter	Symbol	Conditions	HS (high-speed main) Mode		LS (low-speed main) Mode		LP (Low-power main) mode		LV (low-voltage main) Mode		Unit			
			MIN.	MAX.	MIN.	MAX.	MIN.	MAX.	MIN.	MAX.				
Transfer rate Note 2		Transmission	2.7 V ≤ VDD ≤ 3.6 V, 2.3 V ≤ Vb ≤ 2.7 V			Note 1		Note 1		Note 1		bps		
			Theoretical value of the maximum transfer rate Cb = 50 pF, Rb = 2.7 kΩ, Vb = 2.3 V			1.2 Note 2		1.2 Note 2		1.2 Note 2		1.2 Note 2	Mbps	
			1.8 V ≤ VDD < 3.3 V, 1.6 V ≤ Vb ≤ 2.0 V			Notes 3, 4		Notes 3, 4		Notes 3, 4		Notes 3, 4		bps
			Theoretical value of the maximum transfer rate Cb = 50 pF, Rb = 5.5 kΩ, Vb = 1.6 V			0.43 Note 5		0.43 Note 5		0.43 Note 5		0.43 Note 5		Mbps

Note 1. The smaller maximum transfer rate derived by using fmck/6 or the following expression is the valid maximum transfer rate. Expression for calculating the transfer rate when 2.7 V ≤ VDD ≤ 3.6 V and 2.3 V ≤ Vb ≤ 2.7 V

$$\text{Maximum transfer rate} = \frac{1}{\{-C_b \times R_b \times \ln(1 - \frac{2.0}{V_b})\} \times 3} \text{ [bps]}$$

$$\text{Baud rate error (theoretical value)} = \frac{\frac{1}{\text{Transfer rate} \times 2} - \{-C_b \times R_b \times \ln(1 - \frac{2.0}{V_b})\}}{(\frac{1}{\text{Transfer rate}}) \times \text{Number of transferred bits}} \times 100 \text{ [%]}$$

* This value is the theoretical value of the relative difference between the transmission and reception sides.

Note 2. This value as an example is calculated when the conditions described in the “Conditions” column are met. Refer to Note 1 above to calculate the maximum transfer rate under conditions of the customer.

Note 3. Use it with VDD ≥ Vb.

Note 4. The smaller maximum transfer rate derived by using fmck/6 or the following expression is the valid maximum transfer rate. Expression for calculating the transfer rate when 1.8 V ≤ VDD < 3.3 V and 1.6 V ≤ Vb ≤ 2.0 V

$$\text{Maximum transfer rate} = \frac{1}{\{-C_b \times R_b \times \ln(1 - \frac{1.5}{V_b})\} \times 3} \text{ [bps]}$$

$$\text{Baud rate error (theoretical value)} = \frac{\frac{1}{\text{Transfer rate} \times 2} - \{-C_b \times R_b \times \ln(1 - \frac{1.5}{V_b})\}}{(\frac{1}{\text{Transfer rate}}) \times \text{Number of transferred bits}} \times 100 \text{ [%]}$$

* This value is the theoretical value of the relative difference between the transmission and reception sides.

Note 5. This value as an example is calculated when the conditions described in the “Conditions” column are met. Refer to Note 4 above to calculate the maximum transfer rate under conditions of the customer.

Caution Select the TTL input buffer for the RxDq pin and the N-ch open drain output (VDD tolerance) mode for the TxDq pin by using port input mode register g (PIMg) and port output mode register g (POMg). For VIH and VIL, see the DC characteristics with TTL input buffer selected.

(6) Communication at different potential (1.8 V, 2.5 V) (UART mode) (dedicated baud rate generator output)**(TA = +85 to +105°C, 2.4 V ≤ AVDD = VDD ≤ 3.6 V, VSS = AVSS = 0 V)****(1/2)**

Parameter	Symbol	Conditions	HS (high-speed main) Mode		Unit	
			MIN.	MAX.		
Transfer rate ^{Notes 1, 2}		Reception	2.7 V ≤ V _{DD} ≤ 3.6 V, 2.3 V ≤ V _b ≤ 2.7 V		f _{MCK} /12 ^{Note 1}	bps
			Theoretical value of the maximum transfer rate f _{MCK} = f _{CLK} ^{Note 3}		2.0	Mbps
			2.4 V ≤ V _{DD} < 3.3 V, 1.6 V ≤ V _b ≤ 2.0 V		f _{MCK} /12 ^{Notes 1, 2}	bps
			Theoretical value of the maximum transfer rate f _{MCK} = f _{CLK} ^{Note 3}		0.66	Mbps

Note 1. Transfer rate in the SNOOZE mode is 4,800 bps only.**Note 2.** Use it with V_{DD} ≥ V_b.**Note 3.** The maximum operating frequencies of the CPU/peripheral hardware clock (f_{CLK}) are:HS (high-speed main) mode: 24 MHz (2.7 V ≤ V_{DD} ≤ 3.6 V)16 MHz (2.4 V ≤ V_{DD} ≤ 3.6 V)

Caution Select the TTL input buffer for the RxDq pin and the N-ch open drain output (V_{DD} tolerance) mode for the TxDq pin by using port input mode register g (PIMg) and port output mode register g (POMg). For V_{IH} and V_{IL}, see the DC characteristics with TTL input buffer selected.

Remark 1. V_b[V]: Communication line voltage**Remark 2.** q: UART number (q = 0), g: PIM and POM numbers (g = 5)**Remark 3.** f_{MCK}: Serial array unit operation clock frequency

(Operation clock to be set by the CKSmn bit of serial mode register mn (SMRmn). m: Unit number,

n: Channel number (mn = 00, 01)

(6) Communication at different potential (1.8 V, 2.5 V) (UART mode) (dedicated baud rate generator output)

(TA = +85 to +105°C, 2.4 V ≤ AVDD = VDD ≤ 3.6 V, VSS = AVSS = 0 V)

(2/2)

Parameter	Symbol	Conditions	HS (high-speed main) Mode		Unit	
			MIN.	MAX.		
Transfer rate ^{Note 2}		Transmission	2.7 V ≤ V _{DD} ≤ 3.6 V, 2.3 V ≤ V _b ≤ 2.7 V		Note 1	bps
			Theoretical value of the maximum transfer rate C _b = 50 pF, R _b = 2.7 kΩ, V _b = 2.3 V		1.2 ^{Note 2}	Mbps
			2.4 V ≤ V _{DD} < 3.3 V, 1.6 V ≤ V _b ≤ 2.0 V		Notes 3, 4	bps
			Theoretical value of the maximum transfer rate C _b = 50 pF, R _b = 5.5 kΩ, V _b = 1.6 V		0.43 ^{Note 5}	Mbps

Note 1. The smaller maximum transfer rate derived by using $f_{mck}/6$ or the following expression is the valid maximum transfer rate. Expression for calculating the transfer rate when $2.7 V \leq V_{DD} \leq 3.6 V$ and $2.3 V \leq V_b \leq 2.7 V$

$$\text{Maximum transfer rate} = \frac{1}{\{-C_b \times R_b \times \ln(1 - \frac{2.0}{V_b})\} \times 3} \text{ [bps]}$$

$$\text{Baud rate error (theoretical value)} = \frac{\frac{1}{\text{Transfer rate} \times 2} - \{-C_b \times R_b \times \ln(1 - \frac{2.0}{V_b})\}}{(\frac{1}{\text{Transfer rate}}) \times \text{Number of transferred bits}} \times 100 \text{ [%]}$$

* This value is the theoretical value of the relative difference between the transmission and reception sides.

Note 2. This value as an example is calculated when the conditions described in the “Conditions” column are met. Refer to Note 1 above to calculate the maximum transfer rate under conditions of the customer.

Note 3. Use it with $V_{DD} \geq V_b$.

Note 4. The smaller maximum transfer rate derived by using $f_{mck}/6$ or the following expression is the valid maximum transfer rate. Expression for calculating the transfer rate when $2.4 V \leq V_{DD} < 3.3 V$ and $1.6 V \leq V_b \leq 2.0 V$

$$\text{Maximum transfer rate} = \frac{1}{\{-C_b \times R_b \times \ln(1 - \frac{1.5}{V_b})\} \times 3} \text{ [bps]}$$

$$\text{Baud rate error (theoretical value)} = \frac{\frac{1}{\text{Transfer rate} \times 2} - \{-C_b \times R_b \times \ln(1 - \frac{1.5}{V_b})\}}{(\frac{1}{\text{Transfer rate}}) \times \text{Number of transferred bits}} \times 100 \text{ [%]}$$

* This value is the theoretical value of the relative difference between the transmission and reception sides.

Note 5. This value as an example is calculated when the conditions described in the “Conditions” column are met. Refer to Note 4 above to calculate the maximum transfer rate under conditions of the customer.

Caution Select the TTL input buffer for the RxDq pin and the N-ch open drain output (V_{DD} tolerance) mode for the TxDq pin by using port input mode register g (PIMg) and port output mode register g (POMg). For V_{IH} and V_{IL}, see the DC characteristics with TTL input buffer selected.

UART mode connection diagram (during communication at different potential)

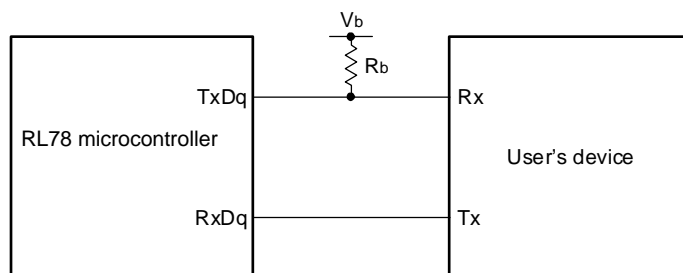

UART mode bit width (during communication at different potential) (reference)

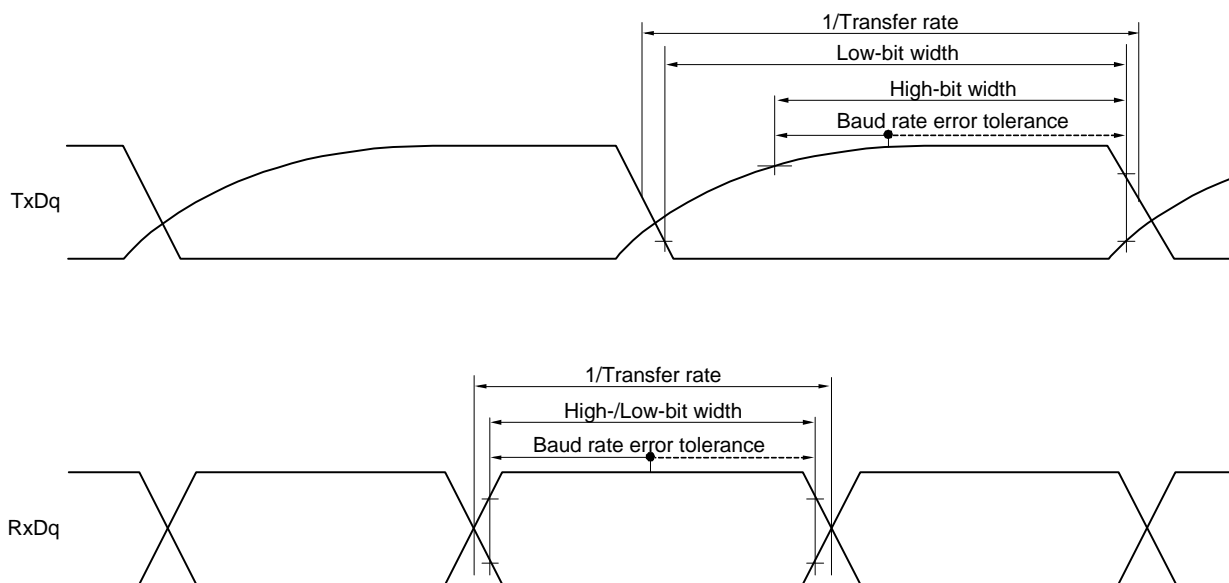

Remark 1. $R_b[\Omega]$: Communication line (TxDq) pull-up resistance, $C_b[F]$: Communication line (TxDq) load capacitance, $V_b[V]$: Communication line voltage

Remark 2. q: UART number (q = 0), g: PIM and POM number (g = 5)

Remark 3. f_{mck} : Serial array unit operation clock frequency
 (Operation clock to be set by the CKSmn bit of serial mode register mn (SMRmn). m: Unit number, n: Channel number (mn = 00, 01))

(7) Communication at different potential (2.5 V) (simplified SPI (CSI) mode) (master mode, SCKp... internal clock output, corresponding CSI00 only)

(TA = -40 to +85°C, 2.7 V ≤ AVDD = VDD ≤ 3.6 V, VSS = AVSS = 0 V)

Parameter	Symbol	Conditions		HS (high-speed main) Mode		LS (low-speed main) Mode		LP (Low-power main) mode		LV (low-voltage main) Mode		Unit
				MIN.	MAX.	MIN.	MAX.	MIN.	MAX.	MIN.	MAX.	
SCKp cycle time	t _{KCY1}	t _{KCY1} ≥ f _{CLK} /2	2.7 V ≤ V _{DD} ≤ 3.6 V, 2.3 V ≤ V _b ≤ 2.7 V, C _b = 20 pF, R _b = 2.7 kΩ	300		1500		1500		1500		ns
SCKp high-level width	t _{KH1}	2.7 V ≤ V _{DD} ≤ 3.6 V, 2.3 V ≤ V _b ≤ 2.7 V, C _b = 20 pF, R _b = 2.7 kΩ		t _{KCY1} /2 - 120		t _{KCY1} /2 - 120		t _{KCY1} /2 - 120		t _{KCY1} /2 - 120		ns
SCKp low-level width	t _{KL1}	2.7 V ≤ V _{DD} ≤ 3.6 V, 2.3 V ≤ V _b ≤ 2.7 V, C _b = 20 pF, R _b = 1.4 kΩ		t _{KCY1} /2 - 10		t _{KCY1} /2 - 50		t _{KCY1} /2 - 50		t _{KCY1} /2 - 50		ns
Slp setup time (to SCKp↑) ^{Note 1}	t _{SIK1}	2.7 V ≤ V _{DD} ≤ 3.6 V, 2.3 V ≤ V _b ≤ 2.7 V, C _b = 20 pF, R _b = 2.7 kΩ		121		479		479		479		ns
Slp hold time (from SCKp↑) ^{Note 1}	t _{KSI1}	2.7 V ≤ V _{DD} ≤ 3.6 V, 2.3 V ≤ V _b ≤ 2.7 V, C _b = 20 pF, R _b = 2.7 kΩ		10		10		10		10		ns
Delay time from SCKp↓ to SOp output ^{Note 1}	t _{KSO1}	2.7 V ≤ V _{DD} ≤ 3.6 V, 2.3 V ≤ V _b ≤ 2.7 V, C _b = 20 pF, R _b = 2.7 kΩ			130		130		130		130	ns
Slp setup time (to SCKp↓) ^{Note 2}	t _{SIK1}	2.7 V ≤ V _{DD} ≤ 3.6 V, 2.3 V ≤ V _b ≤ 2.7 V, C _b = 20 pF, R _b = 2.7 kΩ		33		110		110		110		ns
Slp hold time (from SCKp↓) ^{Note 2}	t _{KSI1}	2.7 V ≤ V _{DD} ≤ 3.6 V, 2.3 V ≤ V _b ≤ 2.7 V, C _b = 20 pF, R _b = 2.7 kΩ		10		10		10		10		ns
Delay time from SCKp↑ to SOp output ^{Note 2}	t _{KSO1}	2.7 V ≤ V _{DD} ≤ 3.6 V, 2.3 V ≤ V _b ≤ 2.7 V, C _b = 20 pF, R _b = 2.7 kΩ			10		10		10		10	ns

Note 1. When DAPmn = 0 and CKPmn = 0, or DAPmn = 1 and CKPmn = 1.

Note 2. When DAPmn = 0 and CKPmn = 1, or DAPmn = 1 and CKPmn = 0.

Caution Select the TTL input buffer for the Slp pin and the N-ch open drain output (V_{DD} tolerance) mode for the SOp pin and SCKp pin by using port input mode register g (PIMg) and port output mode register g (POMg). For V_{IH} and V_{IL}, see the DC characteristics with TTL input buffer selected.

Remark 1. R_b[Ω]: Communication line (SCKp, SOp) pull-up resistance, C_b[F]: Communication line (SCKp, SOp) load capacitance, V_b[V]: Communication line voltage

Remark 2. p: CSI number (p = 00), m: Unit number (m = 0), n: Channel number (n = 0), g: PIM and POM number (g = 5)

Remark 3. f_{MCK}: Serial array unit operation clock frequency
(Operation clock to be set by the CKSmn bit of serial mode register mn (SMRmn). m: Unit number, n: Channel number (mn = 00))

(8) Communication at different potential (1.8 V, 2.5 V) (simplified SPI (CSI) mode) (master mode, SCKp... internal clock output)**(TA = -40 to +85°C, 1.8 V ≤ AVDD = VDD ≤ 3.6 V, VSS = AVSS = 0 V)****(1/2)**

Parameter	Symbol	Conditions	HS (high-speed main) Mode		LS (low-speed main) Mode		LP (Low-power main) mode		LV (low-voltage main) Mode		Unit
			MIN.	MAX.	MIN.	MAX.	MIN.	MAX.	MIN.	MAX.	
SCKp cycle time	tkCY1	tkCY1 ≥ fCLK/4 2.7V ≤ VDD ≤ 3.6 V, 2.3 V ≤ Vb ≤ 2.7 V, Cb = 30 pF, Rb = 2.7 kΩ	500		1150		1150		1150		ns
			1150		1150		1150		1150		ns
SCKp high-level width	tkH1	2.7 V ≤ VDD ≤ 3.6 V, 2.3 V ≤ Vb ≤ 2.7 V, Cb = 30 pF, Rb = 2.7 kΩ	tkCY1/2 - 170		tkCY1/2 - 170		tkCY1/2 - 170		tkCY1/2 - 170		ns
		1.8 V ≤ VDD < 3.3 V, 1.6 V ≤ Vb ≤ 2.0 V Note, Cb = 30 pF, Rb = 5.5 kΩ	tkCY1/2 - 458		tkCY1/2 - 458		tkCY1/2 - 458		tkCY1/2 - 458		ns
SCKp low-level width	tkL1	2.7 V ≤ VDD ≤ 3.6 V, 2.3 V ≤ Vb ≤ 2.7 V, Cb = 30 pF, Rb = 2.7 kΩ	tkCY1/2 - 18		tkCY1/2 - 50		tkCY1/2 - 50		tkCY1/2 - 50		ns
		1.8 V ≤ VDD < 3.3 V, 1.6 V ≤ Vb ≤ 2.0 V Note, Cb = 30 pF, Rb = 5.5 kΩ	tkCY1/2 - 50		tkCY1/2 - 50		tkCY1/2 - 50		tkCY1/2 - 50		ns

Note Use it with VDD ≥ Vb.**Caution** Select the TTL input buffer for the SIp pin and the N-ch open drain output (VDD tolerance) mode for the SOp pin and SCKp pin by using port input mode register g (PIMg) and port output mode register g (POMg). For VIH and VIL, see the DC characteristics with TTL input buffer selected.

(Remarks are listed on the page after the next page.)

(8) Communication at different potential (1.8 V, 2.5 V) (simplified SPI (CSI) mode) (master mode, SCKp... internal clock output)**(TA = -40 to +85°C, 1.8 V ≤ AVDD = VDD ≤ 3.6 V, VSS = AVSS = 0 V)****(2/2)**

Parameter	Symbol	Conditions	HS (high-speed main) Mode		LS (low-speed main) Mode		LP (Low-power main) mode		LV (low-voltage main) Mode		Unit
			MIN.	MAX.	MIN.	MAX.	MIN.	MAX.	MIN.	MAX.	
Slp setup time (to SCKp↑) Note 1	tsIK1	2.7 V ≤ VDD ≤ 3.6 V, 2.3 V ≤ Vb ≤ 2.7 V, Cb = 30 pF, Rb = 2.7 kΩ	177		479		479		479		ns
		1.8 V ≤ VDD < 3.3 V, 1.6 V ≤ Vb ≤ 2.0 V Note 3, Cb = 30 pF, Rb = 5.5 kΩ	479		479		479		479		ns
Slp hold time (from SCKp↓) Note 1	tkSH1	2.7 V ≤ VDD ≤ 3.6 V, 2.3 V ≤ Vb ≤ 2.7 V, Cb = 30 pF, Rb = 2.7 kΩ	19		19		19		19		ns
		1.8 V ≤ VDD < 3.3 V, 1.6 V ≤ Vb ≤ 2.0 V Note 3, Cb = 30 pF, Rb = 5.5 kΩ	19		19		19		19		ns
Delay time from SCKp↓ to SOp output Note 1	tkSO1	2.7 V ≤ VDD ≤ 3.6 V, 2.3 V ≤ Vb ≤ 2.7 V, Cb = 30 pF, Rb = 2.7 kΩ		195		195		195		195	ns
		1.8 V ≤ VDD < 3.3 V, 1.6 V ≤ Vb ≤ 2.0 V Note 3, Cb = 30 pF, Rb = 5.5 kΩ		483		483		483		483	ns
Slp setup time (to SCKp↓) Note 2	tsIK1	2.7 V ≤ VDD ≤ 3.6 V, 2.3 V ≤ Vb ≤ 2.7 V, Cb = 30 pF, Rb = 2.7 kΩ	44		110		110		110		ns
		1.8 V ≤ VDD < 3.3 V, 1.6 V ≤ Vb ≤ 2.0 V Note 3, Cb = 30 pF, Rb = 5.5 kΩ	110		110		110		110		ns
Slp hold time (from SCKp↓) Note 2	tkSH1	2.7 V ≤ VDD ≤ 3.6 V, 2.3 V ≤ Vb ≤ 2.7 V, Cb = 30 pF, Rb = 2.7 kΩ	19		19		19		19		ns
		1.8 V ≤ VDD < 3.3 V, 1.6 V ≤ Vb ≤ 2.0 V Note 3, Cb = 30 pF, Rb = 5.5 kΩ	19		19		19		19		ns
Delay time from SCKp↑ to SOp output Note 2	tkSO1	2.7 V ≤ VDD ≤ 3.6 V, 2.3 V ≤ Vb ≤ 2.7 V, Cb = 30 pF, Rb = 2.7 kΩ		25		25		25		25	ns
		1.8 V ≤ VDD < 3.3 V, 1.6 V ≤ Vb ≤ 2.0 V Note 3, Cb = 30 pF, Rb = 5.5 kΩ		25		25		25		25	ns

Note 1. When DAPmn = 0 and CKPmn = 0, or DAPmn = 1 and CKPmn = 1.**Note 2.** When DAPmn = 0 and CKPmn = 1, or DAPmn = 1 and CKPmn = 0.**Note 3.** Use it with VDD ≥ Vb.

Caution Select the TTL input buffer for the Slp pin and the N-ch open drain output (VDD tolerance) mode for the SOp pin and SCKp pin by using port input mode register g (PIMg) and port output mode register g (POMg). For VIH and VIL, see the DC characteristics with TTL input buffer selected.

(Remarks are listed on the next page.)

Simplified SPI (CSI) mode connection diagram (during communication at different potential)

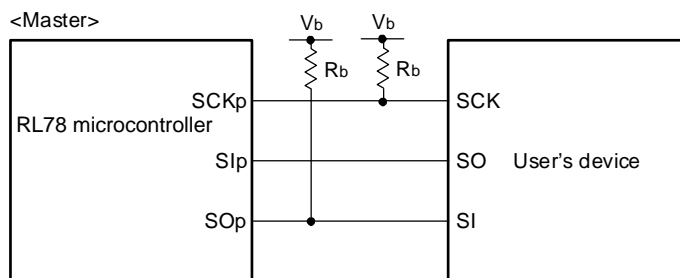

- Remark 1.** $R_b[\Omega]$: Communication line (SCKp, SOp) pull-up resistance, $C_b[F]$: Communication line (SCKp, SOp) load capacitance, $V_b[V]$: Communication line voltage
- Remark 2.** p: CSI number (p = 00, 01), m: Unit number (m = 0), n: Channel number (n = 0, 1), g: PIM and POM numbers (g = 5)
- Remark 3.** f_{mck} : Serial array unit operation clock frequency
(Operation clock to be set by the CKSmn bit of serial mode register mn (SMRmn). m: Unit number, n: Channel number (mn = 00, 01))

**Simplified SPI (CSI) mode serial transfer timing (master mode) (during communication at different potential)
(When DAPmn = 0 and CKPmn = 0, or DAPmn = 1 and CKPmn = 1.)**

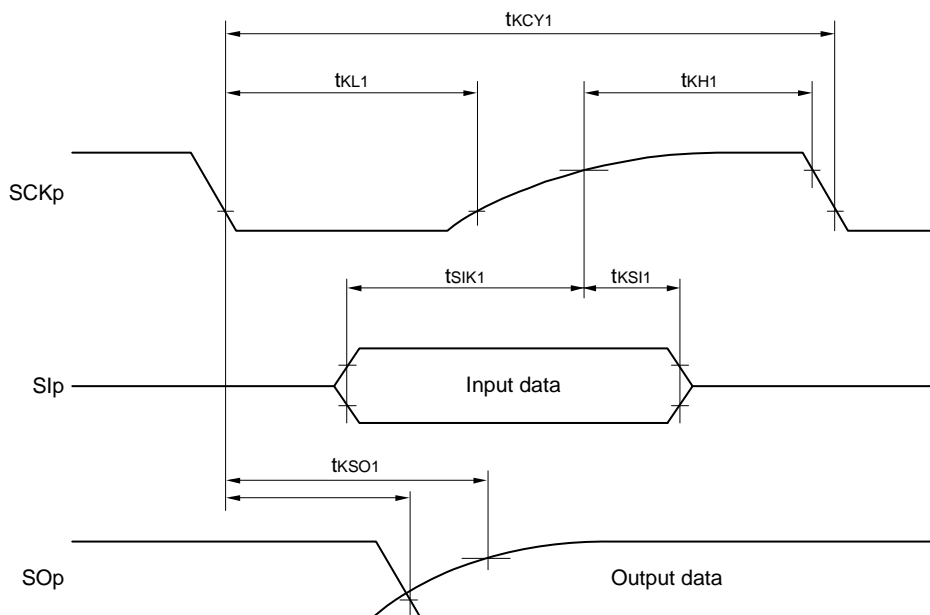

**Simplified SPI (CSI) mode serial transfer timing (master mode) (during communication at different potential)
(When DAPmn = 0 and CKPmn = 1, or DAPmn = 1 and CKPmn = 0.)**

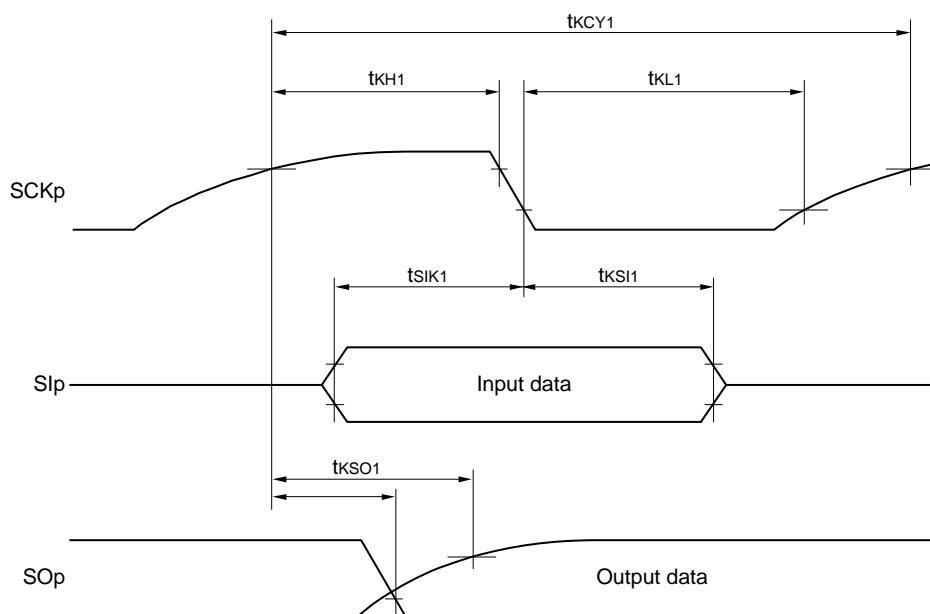

Remark p: CSI number (p = 00, 01), m: Unit number (m = 0), n: Channel number (n = 0, 1), g: PIM and POM numbers (g = 5)

(8) Communication at different potential (1.8 V, 2.5 V) (simplified SPI (CSI) mode) (master mode, SCKp... internal clock output)**(TA = +85 to 105°C, 2.4 V ≤ AVDD = VDD ≤ 3.6 V, VSS = AVSS = 0 V)****(1/2)**

Parameter	Symbol	Conditions	HS (high-speed main) Mode		Unit
			MIN.	MAX.	
SCKp cycle time	tkCY1	tkCY1 ≥ fCLK/4 2.7 V ≤ VDD ≤ 3.6 V, 2.3 V ≤ Vb ≤ 2.7 V, Cb = 30 pF, Rb = 2.7 kΩ	1000		ns
			2300		ns
SCKp high-level width	tkH1	2.7 V ≤ VDD ≤ 3.6 V, 2.3 V ≤ Vb ≤ 2.7 V, Cb = 30 pF, Rb = 2.7 kΩ	tkCY1/2 - 340		ns
		2.4 V ≤ VDD < 3.3 V, 1.6 V ≤ Vb ≤ 2.0 V, Cb = 30 pF, Rb = 5.5 kΩ	tkCY1/2 - 916		ns
SCKp low-level width	tkL1	2.7 V ≤ VDD ≤ 3.6 V, 2.3 V ≤ Vb ≤ 2.7 V, Cb = 30 pF, Rb = 2.7 kΩ	tkCY1/2 - 36		ns
		2.4 V ≤ VDD < 3.3 V, 1.6 V ≤ Vb ≤ 2.0 V, Cb = 30 pF, Rb = 5.5 kΩ	tkCY1/2 - 100		ns

Caution Select the TTL input buffer for the SIp pin and the N-ch open drain output (VDD tolerance) mode for the SOp pin and SCKp pin by using port input mode register g (PIMg) and port output mode register g (POMg). For VIH and VIL, see the DC characteristics with TTL input buffer selected.

(Remarks are listed on the page after the next page.)

(8) Communication at different potential (1.8 V, 2.5 V) (simplified SPI (CSI) mode) (master mode, SCKp... internal clock output)**(TA = +85 to 105°C, 2.4 V ≤ AVDD = VDD ≤ 3.6 V, VSS = AVSS = 0 V)****(2/2)**

Parameter	Symbol	Conditions	HS (high-speed main) Mode		Unit
			MIN.	MAX.	
Slp setup time (to SCKp↑) ^{Note 1}	tSIK1	2.7 V ≤ VDD ≤ 3.6 V, 2.3 V ≤ Vb ≤ 2.7 V, Cb = 30 pF, Rb = 2.7 kΩ	354		ns
		2.4 V ≤ VDD < 3.3 V, 1.6 V ≤ Vb ≤ 2.0 V ^{Note 3} , Cb = 30 pF, Rb = 5.5 kΩ	958		ns
Slp hold time (from SCKp↑) ^{Note 1}	tKS11	2.7 V ≤ VDD ≤ 3.6 V, 2.3 V ≤ Vb ≤ 2.7 V, Cb = 30 pF, Rb = 2.7 kΩ	38		ns
		2.4 V ≤ VDD < 3.3 V, 1.6 V ≤ Vb ≤ 2.0 V ^{Note 3} , Cb = 30 pF, Rb = 5.5 kΩ	38		ns
Delay time from SCKp↓ to SOp output ^{Note 1}	tKSO1	2.7 V ≤ VDD ≤ 3.6 V, 2.3 V ≤ Vb ≤ 2.7 V, Cb = 30 pF, Rb = 2.7 kΩ		390	ns
		2.4 V ≤ VDD < 3.3 V, 1.6 V ≤ Vb ≤ 2.0 V ^{Note 3} , Cb = 30 pF, Rb = 5.5 kΩ		966	ns
Slp setup time (to SCKp↓) ^{Note 2}	tSIK1	2.7 V ≤ VDD ≤ 3.6 V, 2.3 V ≤ Vb ≤ 2.7 V, Cb = 30 pF, Rb = 2.7 kΩ	88		ns
		2.4 V ≤ VDD < 3.3 V, 1.6 V ≤ Vb ≤ 2.0 V ^{Note 3} , Cb = 30 pF, Rb = 5.5 kΩ	220		ns
Slp hold time (from SCKp↓) ^{Note 2}	tKS11	2.7 V ≤ VDD ≤ 3.6 V, 2.3 V ≤ Vb ≤ 2.7 V, Cb = 30 pF, Rb = 2.7 kΩ	38		ns
		2.4 V ≤ VDD < 3.3 V, 1.6 V ≤ Vb ≤ 2.0 V ^{Note 3} , Cb = 30 pF, Rb = 5.5 kΩ	38		ns
Delay time from SCKp↑ to SOp output ^{Note 2}	tKSO1	2.7 V ≤ VDD ≤ 3.6 V, 2.3 V ≤ Vb ≤ 2.7 V, Cb = 30 pF, Rb = 2.7 kΩ		50	ns
		2.4 V ≤ VDD < 3.3 V, 1.6 V ≤ Vb ≤ 2.0 V ^{Note 3} , Cb = 30 pF, Rb = 5.5 kΩ		50	ns

Note 1. When DAPmn = 0 and CKPmn = 0, or DAPmn = 1 and CKPmn = 1.**Note 2.** When DAPmn = 0 and CKPmn = 1, or DAPmn = 1 and CKPmn = 0.**Note 3.** Use it with VDD ≥ Vb.

Caution Select the TTL input buffer for the Slp pin and the N-ch open drain output (VDD tolerance) mode for the SOp pin and SCKp pin by using port input mode register g (PIMg) and port output mode register g (POMg). For VIH and VIL, see the DC characteristics with TTL input buffer selected.

(Remarks are listed on the next page.)

Simplified SPI (CSI) mode connection diagram (during communication at different potential)

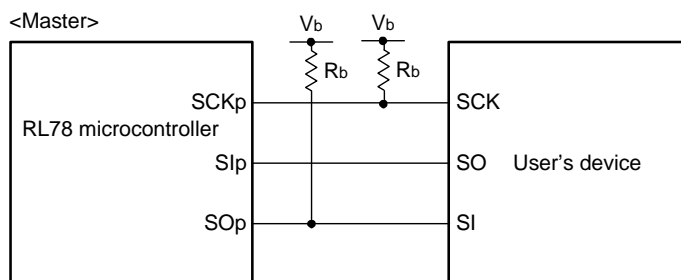

Remark 1. $R_b[\Omega]$: Communication line (SCKp, SOp) pull-up resistance, $C_b[F]$: Communication line (SCKp, SOp) load capacitance, $V_b[V]$: Communication line voltage

Remark 2. p: CSI number (p = 00, 01), m: Unit number (m = 0), n: Channel number (n = 0, 1), g: PIM and POM numbers (g = 5)

Remark 3. f_{mck} : Serial array unit operation clock frequency
 (Operation clock to be set by the CKSmn bit of serial mode register mn (SMRmn). m: Unit number, n: Channel number (mn = 00, 01))

**Simplified SPI (CSI) mode serial transfer timing (master mode) (during communication at different potential)
(When DAPmn = 0 and CKPmn = 0, or DAPmn = 1 and CKPmn = 1.)**

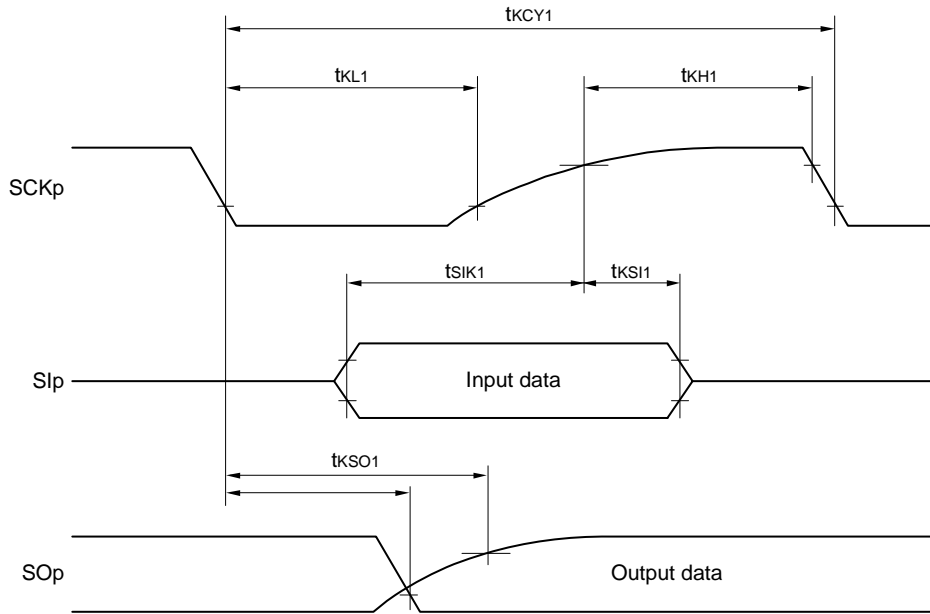

**Simplified SPI (CSI) mode serial transfer timing (master mode) (during communication at different potential)
(When DAPmn = 0 and CKPmn = 1, or DAPmn = 1 and CKPmn = 0.)**

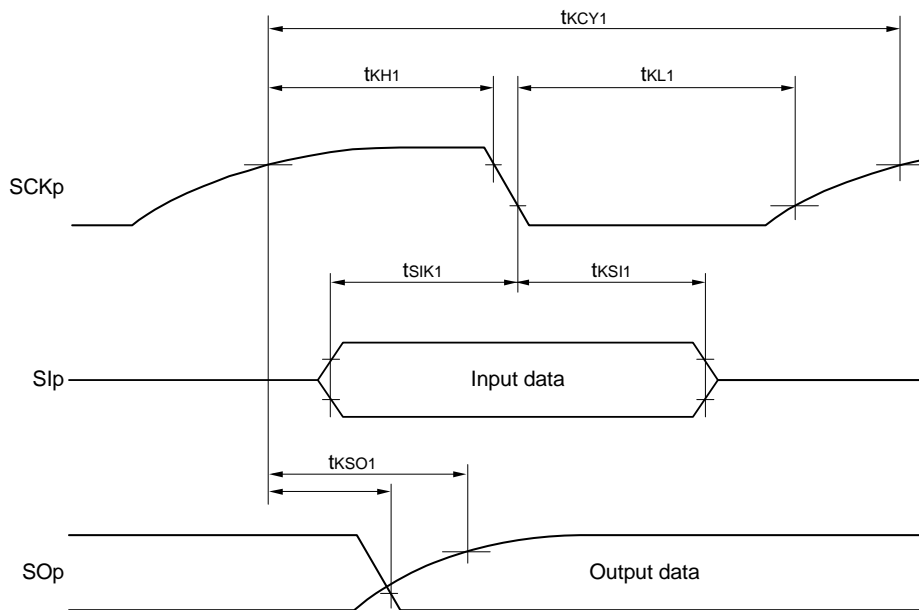

Remark p: CSI number (p = 00, 01), m: Unit number (m = 0), n: Channel number (n = 0, 1), g: PIM and POM numbers (g = 5)

(9) Communication at different potential (1.8 V, 2.5 V) (simplified SPI (CSI) mode) (slave mode, SCKp... external clock input)

(TA = -40 to 85°C, 1.8 V ≤ AVDD = VDD ≤ 3.6 V, VSS = AVSS = 0 V)

Parameter	Symbol	Conditions	HS (high-speed main) Mode		LS (low-speed main) Mode		LP (Low-power main) mode		LV (low-voltage main) Mode		Unit	
			MIN.	MAX.	MIN.	MAX.	MIN.	MAX.	MIN.	MAX.		
SCKp cycle time Note 1	tkcy2	2.7 V ≤ VDD ≤ 3.6 V, 2.3 V ≤ Vb ≤ 2.7 V	20 MHz < fMCK ≤ 24 MHz	16/fMCK		—		—		—		ns
			16 MHz < fMCK ≤ 20 MHz	14/fMCK		—		—		—		ns
			8 MHz < fMCK ≤ 16 MHz	12/fMCK		—		—		—		ns
			4 MHz < fMCK ≤ 8 MHz	8/fMCK		16/fMCK		—		—		ns
			fMCK ≤ 4 MHz	6/fMCK		10/fMCK		10/fMCK		10/fMCK		ns
		1.8 V ≤ VDD < 3.3 V, 1.6 V ≤ Vb ≤ 2.0 V Note 2	20 MHz < fMCK ≤ 24 MHz	36/fMCK		—		—		—		ns
			16 MHz < fMCK ≤ 20 MHz	32/fMCK		—		—		—		ns
			8 MHz < fMCK ≤ 16 MHz	26/fMCK		—		—		—		ns
			4 MHz < fMCK ≤ 8 MHz	16/fMCK		16/fMCK		—		—		ns
			fMCK ≤ 4 MHz	10/fMCK		10/fMCK		10/fMCK		10/fMCK		ns
SCKp high-/low-level width	tkH2, tkL2	2.7 V ≤ VDD ≤ 3.6 V, 2.3 V ≤ Vb ≤ 2.7 V	tkcy2/2 - 18		tkcy2/2 - 50		tkcy2/2 - 50		tkcy2/2 - 50		ns	
		1.8 V ≤ VDD < 3.3 V, 1.6 V ≤ Vb ≤ 2.0 V Note 2	tkcy2/2 - 50		tkcy2/2 - 50		tkcy2/2 - 50		tkcy2/2 - 50		ns	
Slp setup time (to SCKp↑) Note 3	tsiK2	2.7 V ≤ VDD ≤ 3.6 V, 2.3 V ≤ Vb ≤ 2.7 V	1/fMCK + 20		1/fMCK + 30		1/fMCK + 30		1/fMCK + 30		ns	
		1.8 V ≤ VDD < 3.3 V, 1.6 V ≤ Vb ≤ 2.0 V Note 2	1/fMCK + 30		1/fMCK + 30		1/fMCK + 30		1/fMCK + 30		ns	
Slp hold time (from SCKp↑) Note 4	tkSi2		1/fMCK + 31		1/fMCK + 31		1/fMCK + 31		1/fMCK + 31		ns	
Delay time from SCKp↓ to SOp output Note 5	tkSO2	2.7 V ≤ VDD ≤ 3.6 V, 2.3 V ≤ Vb ≤ 2.7 V, Cb = 30 pF, Rb = 2.7 kΩ		2/fMCK + 214		2/fMCK + 573		2/fMCK + 573		2/fMCK + 573	ns	
		1.8 V ≤ VDD < 3.3 V, 1.6 V ≤ Vb ≤ 2.0 V Note 2, Cb = 30 pF, Rb = 5.5 kΩ		2/fMCK + 573		2/fMCK + 573		2/fMCK + 573		2/fMCK + 573	ns	

(Notes and Caution are listed on the next page. Remarks are listed on the page after the next page.)

- Note 1.** Transfer rate in the SNOOZE mode: MAX. 1 Mbps
- Note 2.** Use it with $V_{DD} \geq V_b$.
- Note 3.** When $DAPmn = 0$ and $CKPmn = 0$, or $DAPmn = 1$ and $CKPmn = 1$. The SIp setup time becomes "to $SCKp\downarrow$ " when $DAPmn = 0$ and $CKPmn = 1$, or $DAPmn = 1$ and $CKPmn = 0$.
- Note 4.** When $DAPmn = 0$ and $CKPmn = 0$, or $DAPmn = 1$ and $CKPmn = 1$. The SIp hold time becomes "from $SCKp\downarrow$ " when $DAPmn = 0$ and $CKPmn = 1$, or $DAPmn = 1$ and $CKPmn = 0$.
- Note 5.** When $DAPmn = 0$ and $CKPmn = 0$, or $DAPmn = 1$ and $CKPmn = 1$. The delay time to SOp output becomes "from $SCKp\uparrow$ " when $DAPmn = 0$ and $CKPmn = 1$, or $DAPmn = 1$ and $CKPmn = 0$.
- Caution** Select the TTL input buffer for the SIp pin and SCKp pin and the N-ch open drain output (V_{DD} tolerance) mode for the SOp pin by using port input mode register g (PIMg) and port output mode register g (POMg). For V_{IH} and V_{IL} , see the DC characteristics with TTL input buffer selected.

(Remarks are listed on the next page.)

Simplified SPI (CSI) mode connection diagram (during communication at different potential)

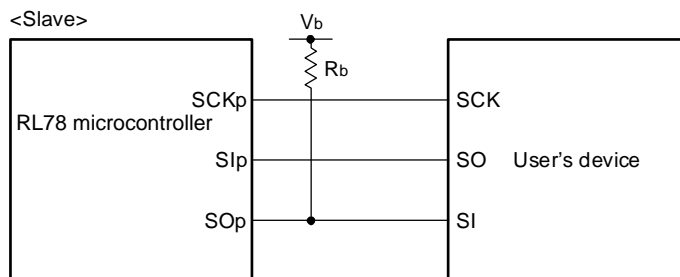

Remark 1. $R_b[\Omega]$: Communication line (SO_p) pull-up resistance, $C_b[F]$: Communication line (SO_p) load capacitance, $V_b[V]$: Communication line voltage

Remark 2. p: CSI number (p = 00, 01), m: Unit number (m = 0), n: Channel number (n = 0, 1), g: PIM and POM numbers (g = 5)

Remark 3. f_{mck} : Serial array unit operation clock frequency
 (Operation clock to be set by the CKSmn bit of serial mode register mn (SMRmn). m: Unit number, n: Channel number (mn = 00, 01))

**Simplified SPI (CSI) mode serial transfer timing (slave mode) (during communication at different potential)
(When DAPmn = 0 and CKPmn = 0, or DAPmn = 1 and CKPmn = 1.)**

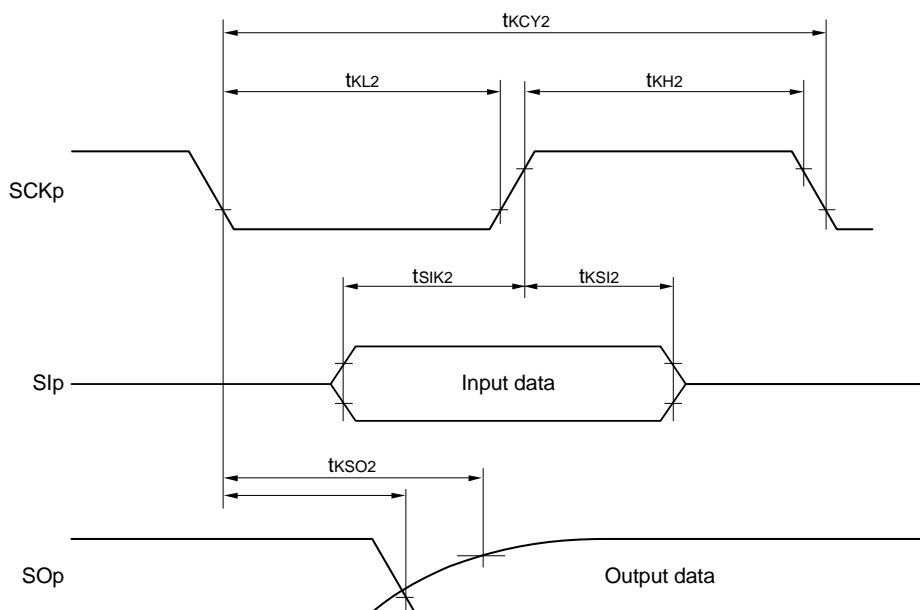

**Simplified SPI (CSI) mode serial transfer timing (slave mode) (during communication at different potential)
(When DAPmn = 0 and CKPmn = 1, or DAPmn = 1 and CKPmn = 0.)**

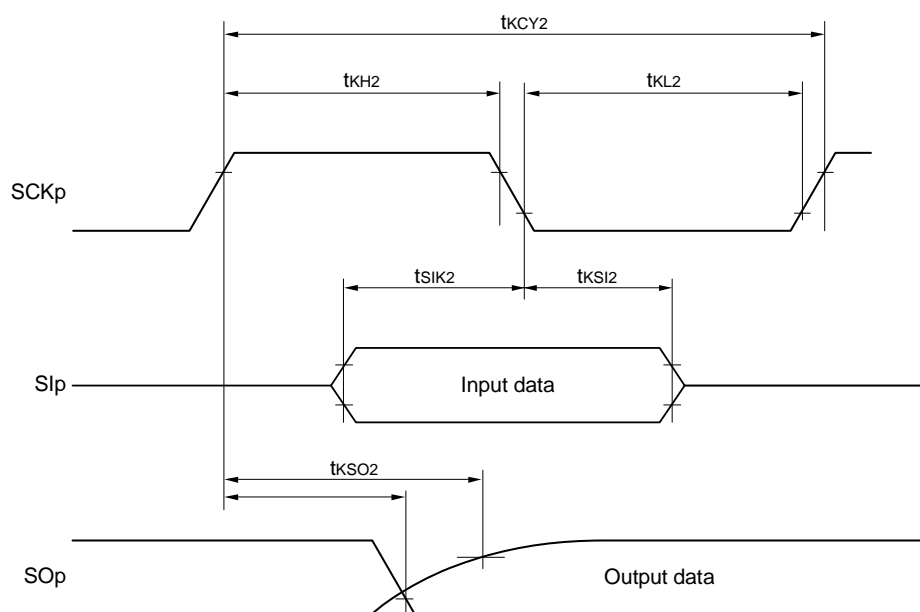

Remark p: CSI number (p = 00, 01), m: Unit number (m = 0), n: Channel number (n = 0, 1), g: PIM and POM numbers (g = 5)

(9) Communication at different potential (1.8 V, 2.5 V) (simplified SPI (CSI) mode) (slave mode, SCKp... external clock input)**(TA = +85 to 105°C, 2.4 V ≤ AVDD = VDD ≤ 3.6 V, VSS = AVSS = 0 V)**

Parameter	Symbol	Conditions	HS (high-speed main) Mode		Unit	
			MIN.	MAX.		
SCKp cycle time ^{Note 1}	tkCY2	2.7 V ≤ VDD ≤ 3.6 V, 2.3 V ≤ Vb ≤ 2.7 V	20 MHz < fMCK ≤ 24 MHz	32/fMCK		ns
			16 MHz < fMCK ≤ 20 MHz	28/fMCK		ns
			8 MHz < fMCK ≤ 16 MHz	24/fMCK		ns
			4 MHz < fMCK ≤ 8 MHz	16/fMCK		ns
			fMCK ≤ 4 MHz	12/fMCK		ns
		2.4 V ≤ VDD < 3.3 V, 1.6 V ≤ Vb ≤ 2.0 V ^{Note 2}	20 MHz < fMCK ≤ 24 MHz	72/fMCK		ns
			16 MHz < fMCK ≤ 20 MHz	64/fMCK		ns
			8 MHz < fMCK ≤ 16 MHz	52/fMCK		ns
			4 MHz < fMCK ≤ 8 MHz	32/fMCK		ns
			fMCK ≤ 4 MHz	20/fMCK		ns
SCKp high-/low-level width	tkH2, tkL2	2.7 V ≤ VDD ≤ 3.6 V, 2.3 V ≤ Vb ≤ 2.7 V	tkCY2/2 - 36		ns	
		2.4 V ≤ VDD < 3.3 V, 1.6 V ≤ Vb ≤ 2.0 V ^{Note 2}	tkCY2/2 - 100		ns	
Slp setup time (to SCKp↑) ^{Note 3}	tsIK2	2.7 V ≤ VDD ≤ 3.6 V, 2.3 V ≤ Vb ≤ 2.7 V	1/fMCK + 40		ns	
		2.4 V ≤ VDD < 3.3 V, 1.6 V ≤ Vb ≤ 2.0 V ^{Note 2}	1/fMCK + 60		ns	
Slp hold time (from SCKp↑) ^{Note 4}	tkSI2		1/fMCK + 62		ns	
Delay time from SCKp↓ to SOp output ^{Note 5}	tkSO2	2.7 V ≤ VDD ≤ 3.6 V, 2.3 V ≤ Vb ≤ 2.7 V Cb = 30 pF, Rb = 2.7 kΩ		2/fMCK + 428	ns	
		2.4 V ≤ VDD < 3.3 V, 1.6 V ≤ Vb ≤ 2.0 V ^{Note 2} Cb = 30 pF, Rb = 5.5 kΩ		2/fMCK + 1146	ns	

(Notes and Caution are listed on the next page. Remarks are listed on the page after the next page.)

- Note 1.** Transfer rate in the SNOOZE mode: MAX. 1 Mbps
- Note 2.** Use it with $V_{DD} \geq V_b$.
- Note 3.** When $DAPmn = 0$ and $CKPmn = 0$, or $DAPmn = 1$ and $CKPmn = 1$. The SIp setup time becomes “to $SCKp\downarrow$ ” when $DAPmn = 0$ and $CKPmn = 1$, or $DAPmn = 1$ and $CKPmn = 0$.
- Note 4.** When $DAPmn = 0$ and $CKPmn = 0$, or $DAPmn = 1$ and $CKPmn = 1$. The SIp hold time becomes “from $SCKp\downarrow$ ” when $DAPmn = 0$ and $CKPmn = 1$, or $DAPmn = 1$ and $CKPmn = 0$.
- Note 5.** When $DAPmn = 0$ and $CKPmn = 0$, or $DAPmn = 1$ and $CKPmn = 1$. The delay time to SOp output becomes “from $SCKp\uparrow$ ” when $DAPmn = 0$ and $CKPmn = 1$, or $DAPmn = 1$ and $CKPmn = 0$.
- Caution** **Select the TTL input buffer for the SIp pin and SCKp pin and the N-ch open drain output (V_{DD} tolerance) mode for the SOp pin by using port input mode register g (PIMg) and port output mode register g (POMg). For V_{IH} and V_{IL} , see the DC characteristics with TTL input buffer selected.**

(Remarks are listed on the next page.)

Simplified SPI (CSI) mode connection diagram (during communication at different potential)

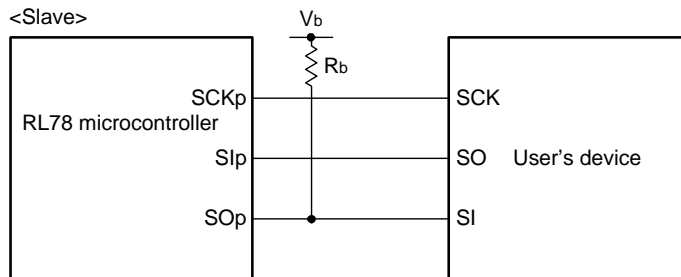

Remark 1. $R_b[\Omega]$: Communication line (SO_p) pull-up resistance, $C_b[F]$: Communication line (SO_p) load capacitance, $V_b[V]$: Communication line voltage

Remark 2. p: CSI number (p = 00, 01), m: Unit number (m = 0), n: Channel number (n = 0, 1), g: PIM and POM numbers (g = 5)

Remark 3. f_{MCK} : Serial array unit operation clock frequency
 (Operation clock to be set by the CKSmn bit of serial mode register mn (SMRmn). m: Unit number, n: Channel number (mn = 00, 01))

**Simplified SPI (CSI) mode serial transfer timing (slave mode) (during communication at different potential)
(When DAPmn = 0 and CKPmn = 0, or DAPmn = 1 and CKPmn = 1.)**

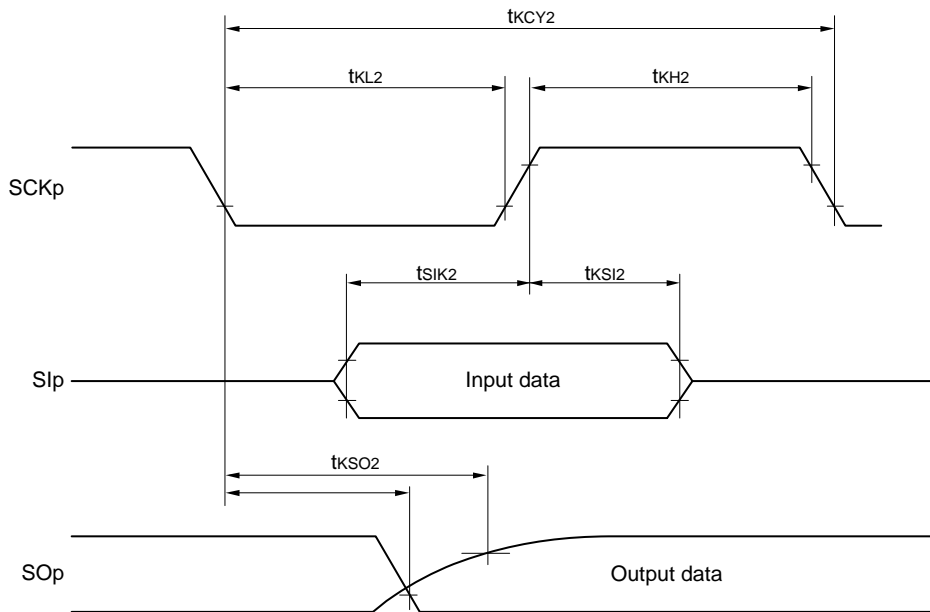

**Simplified SPI (CSI) mode serial transfer timing (slave mode) (during communication at different potential)
(When DAPmn = 0 and CKPmn = 1, or DAPmn = 1 and CKPmn = 0.)**

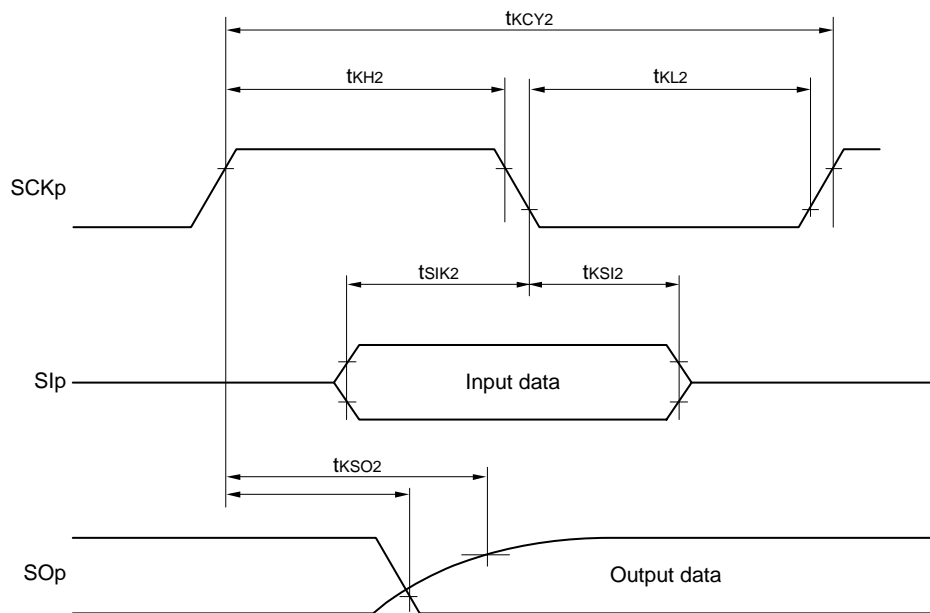

Remark p: CSI number (p = 00, 01), m: Unit number (m = 0), n: Channel number (n = 0, 1), g: PIM and POM numbers (g = 5)

(10) Communication at different potential (1.8 V, 2.5 V) (simplified I²C mode)**(TA = -40 to 85°C, 1.8 V ≤ AVDD = VDD ≤ 3.6 V, VSS = AVSS = 0 V)**

Parameter	Symbol	Conditions	HS (high-speed main) Mode		LS (low-speed main) Mode		LP (Low-power main) mode		LV (low-voltage main) Mode		Unit
			MIN.	MAX.	MIN.	MAX.	MIN.	MAX.	MIN.	MAX.	
SCLr clock frequency	f _{SCL}	2.7 V ≤ V _{DD} ≤ 3.6 V, 2.3 V ≤ V _b ≤ 2.7 V, C _b = 50 pF, R _b = 2.7 kΩ		1000 Note 1		300 Note 1		250 Note 1		300 Note 1	kHz
		2.7 V ≤ V _{DD} ≤ 3.6 V, 2.3 V ≤ V _b ≤ 2.7 V, C _b = 100 pF, R _b = 2.7 kΩ		400 Note 1		300 Note 1		250 Note 1		300 Note 1	kHz
		1.8 V ≤ V _{DD} < 3.3 V, 1.6 V ≤ V _b ≤ 2.0 V Note 2, C _b = 100 pF, R _b = 5.5 kΩ		300 Note 1		300 Note 1		250 Note 1		300 Note 1	kHz
Hold time when SCLr = "L"	t _{LOW}	2.7 V ≤ V _{DD} ≤ 3.6 V, 2.3 V ≤ V _b ≤ 2.7 V, C _b = 50 pF, R _b = 2.7 kΩ	475		1550		1550		1550		ns
		2.7 V ≤ V _{DD} ≤ 3.6 V, 2.3 V ≤ V _b ≤ 2.7 V, C _b = 100 pF, R _b = 2.7 kΩ	1150		1550		1550		1550		ns
		1.8 V ≤ V _{DD} < 3.3 V, 1.6 V ≤ V _b ≤ 2.0 V Note 2, C _b = 100 pF, R _b = 5.5 kΩ	1550		1550		1550		1550		ns
Hold time when SCLr = "H"	t _{HIGH}	2.7 V ≤ V _{DD} ≤ 3.6 V, 2.3 V ≤ V _b ≤ 2.7 V, C _b = 50 pF, R _b = 2.7 kΩ	200		610		610		610		ns
		2.7 V ≤ V _{DD} ≤ 3.6 V, 2.3 V ≤ V _b ≤ 2.7 V, C _b = 100 pF, R _b = 2.7 kΩ	600		610		610		610		ns
		1.8 V ≤ V _{DD} < 3.3 V, 1.6 V ≤ V _b ≤ 2.0 V Note 2, C _b = 100 pF, R _b = 5.5 kΩ	610		610		610		610		ns
Data setup time (reception)	t _{SU-DAT}	2.7 V ≤ V _{DD} ≤ 3.6 V, 2.3 V ≤ V _b ≤ 2.7 V, C _b = 50 pF, R _b = 2.7 kΩ	1/f _{MCK} + 135 Note 3		1/f _{MCK} + 190 Note 2		1/f _{MCK} + 190 Note 3		1/f _{MCK} + 190 Note 3		ns
		2.7 V ≤ V _{DD} ≤ 3.6 V, 2.3 V ≤ V _b ≤ 2.7 V, C _b = 100 pF, R _b = 2.7 kΩ	1/f _{MCK} + 190 Note 3		1/f _{MCK} + 190 Note 3		1/f _{MCK} + 190 Note 3		1/f _{MCK} + 190 Note 3		ns
		1.8 V ≤ V _{DD} < 3.3 V, 1.6 V ≤ V _b ≤ 2.0 V Note 2, C _b = 100 pF, R _b = 5.5 kΩ	1/f _{MCK} + 190 Note 3		1/f _{MCK} + 190 Note 3		1/f _{MCK} + 190 Note 3		1/f _{MCK} + 190 Note 3		ns
Data hold time (transmission)	t _{HD-DAT}	2.7 V ≤ V _{DD} ≤ 3.6 V, 2.3 V ≤ V _b ≤ 2.7 V, C _b = 50 pF, R _b = 2.7 kΩ	0	305	0	305	0	305	0	305	ns
		2.7 V ≤ V _{DD} ≤ 3.6 V, 2.3 V ≤ V _b ≤ 2.7 V, C _b = 100 pF, R _b = 2.7 kΩ	0	355	0	355	0	355	0	355	ns
		1.8 V ≤ V _{DD} < 3.3 V, 1.6 V ≤ V _b ≤ 2.0 V Note 2, C _b = 100 pF, R _b = 5.5 kΩ	0	405	0	405	0	405	0	405	ns

Note 1. The value must also be equal to or less than f_{MCK}/4.**Note 2.** Use it with V_{DD} ≥ V_b.**Note 3.** Set the f_{MCK} value to keep the hold time of SCLr = "L" and SCLr = "H".

Caution Select the TTL input buffer and the N-ch open drain output (V_{DD} tolerance) mode for the SDAr pin and the N-ch open drain output (V_{DD} tolerance) mode for the SCLr pin by using port input mode register g (PIMg) and port output mode register g (POMg). For V_{IH} and V_{IL}, see the DC characteristics with TTL input buffer selected.

(Remarks are listed on the next page.)

Simplified I²C mode connection diagram (during communication at different potential)

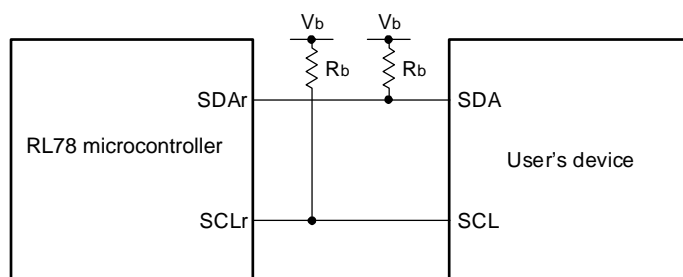

Simplified I²C mode serial transfer timing (during communication at different potential)

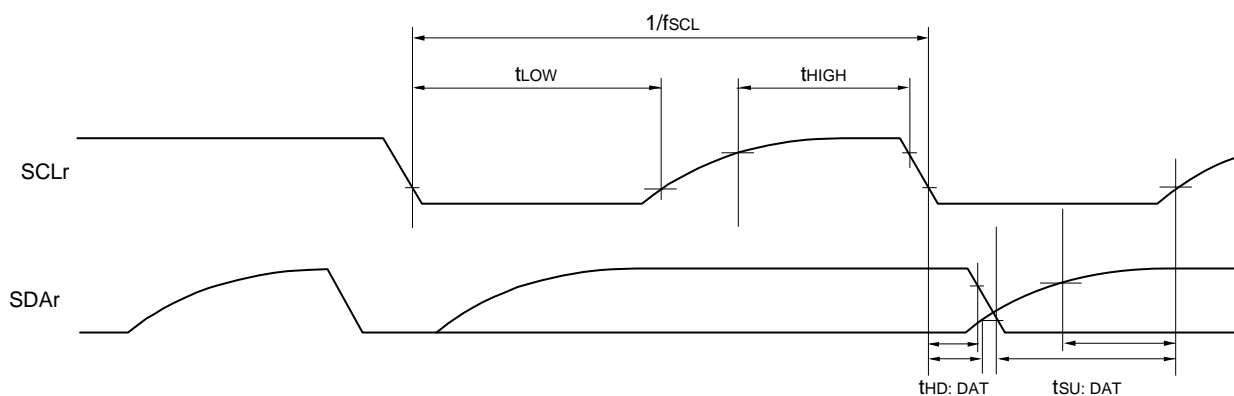

- Remark 1.** $R_b[\Omega]$: Communication line (SDAr, SCLr) pull-up resistance, $C_b[F]$: Communication line (SDAr, SCLr) load capacitance, $V_b[V]$: Communication line voltage
- Remark 2.** r: IIC number (r = 00, 01), g: PIM, POM number (g = 5)
- Remark 3.** f_{mck} : Serial array unit operation clock frequency
(Operation clock to be set by the CKSmn bit of serial mode register mn (SMRmn). m: Unit number (m = 0), n: Channel number (n = 0, 1), mn = 00, 01)

(10) Communication at different potential (1.8 V, 2.5 V) (simplified I²C mode)**(T_A = +85 to 105°C, 2.4 V ≤ AV_{DD} = V_{DD} ≤ 3.6 V, V_{SS} = AV_{SS} = 0 V)**

Parameter	Symbol	Conditions	HS (high-speed main) Mode		Unit
			MIN.	MAX.	
SCLr clock frequency	fsCL	2.7 V ≤ V _{DD} ≤ 3.6 V, 2.3 V ≤ V _b ≤ 2.7 V, C _b = 50 pF, R _b = 2.7 kΩ		400 Note 1	kHz
		2.7 V ≤ V _{DD} ≤ 3.6 V, 2.3 V ≤ V _b ≤ 2.7 V, C _b = 100 pF, R _b = 2.7 kΩ		100 Note 1	kHz
		2.4 V ≤ V _{DD} < 3.3 V, 1.6 V ≤ V _b ≤ 2.0 V Note 2, C _b = 100 pF, R _b = 5.5 kΩ		100 Note 1	kHz
Hold time when SCLr = "L"	t _{LOW}	2.7 V ≤ V _{DD} ≤ 3.6 V, 2.3 V ≤ V _b ≤ 2.7 V, C _b = 50 pF, R _b = 2.7 kΩ	1200		ns
		2.7 V ≤ V _{DD} ≤ 3.6 V, 2.3 V ≤ V _b ≤ 2.7 V, C _b = 100 pF, R _b = 2.7 kΩ	4600		ns
		2.4 V ≤ V _{DD} < 3.3 V, 1.6 V ≤ V _b ≤ 2.0 V Note 2, C _b = 100 pF, R _b = 5.5 kΩ	4650		ns
Hold time when SCLr = "H"	t _{HIGH}	2.7 V ≤ V _{DD} ≤ 3.6 V, 2.3 V ≤ V _b ≤ 2.7 V, C _b = 50 pF, R _b = 2.7 kΩ	500		ns
		2.7 V ≤ V _{DD} ≤ 3.6 V, 2.3 V ≤ V _b ≤ 2.7 V, C _b = 100 pF, R _b = 2.7 kΩ	2400		ns
		2.4 V ≤ V _{DD} < 3.3 V, 1.6 V ≤ V _b ≤ 2.0 V Note 2, C _b = 100 pF, R _b = 5.5 kΩ	1830		ns
Data setup time (reception)	t _{SU-DAT}	2.7 V ≤ V _{DD} ≤ 3.6 V, 2.3 V ≤ V _b ≤ 2.7 V, C _b = 50 pF, R _b = 2.7 kΩ	1/f _{MCK} + 340 Note 3		ns
		2.7 V ≤ V _{DD} ≤ 3.6 V, 2.3 V ≤ V _b ≤ 2.7 V, C _b = 100 pF, R _b = 2.7 kΩ	1/f _{MCK} + 760 Note 3		ns
		2.4 V ≤ V _{DD} < 3.3 V, 1.6 V ≤ V _b ≤ 2.0 V Note 2, C _b = 100 pF, R _b = 5.5 kΩ	1/f _{MCK} + 570 Note 3		ns
Data hold time (transmission)	t _{HD-DAT}	2.7 V ≤ V _{DD} ≤ 3.6 V, 2.3 V ≤ V _b ≤ 2.7 V, C _b = 50 pF, R _b = 2.7 kΩ	0	770	ns
		2.7 V ≤ V _{DD} ≤ 3.6 V, 2.3 V ≤ V _b ≤ 2.7 V, C _b = 100 pF, R _b = 2.7 kΩ	0	1420	ns
		2.4 V ≤ V _{DD} < 3.3 V, 1.6 V ≤ V _b ≤ 2.0 V Note 2, C _b = 100 pF, R _b = 5.5 kΩ	0	1215	ns

Note 1. The value must also be equal to or less than f_{MCK}/4.**Note 2.** Use it with V_{DD} ≥ V_b.**Note 3.** Set the f_{MCK} value to keep the hold time of SCLr = "L" and SCLr = "H".

Caution Select the TTL input buffer and the N-ch open drain output (V_{DD} tolerance) mode for the SDAr pin and the N-ch open drain output (V_{DD} tolerance) mode for the SCLr pin by using port input mode register g (PIMg) and port output mode register g (POMg). For V_{IH} and V_{IL}, see the DC characteristics with TTL input buffer selected.

(Remarks are listed on the next page.)

Simplified I²C mode connection diagram (during communication at different potential)

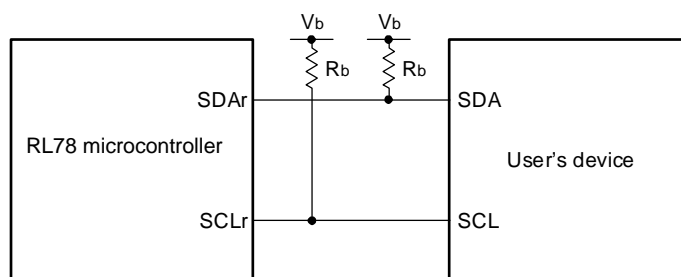

Simplified I²C mode serial transfer timing (during communication at different potential)

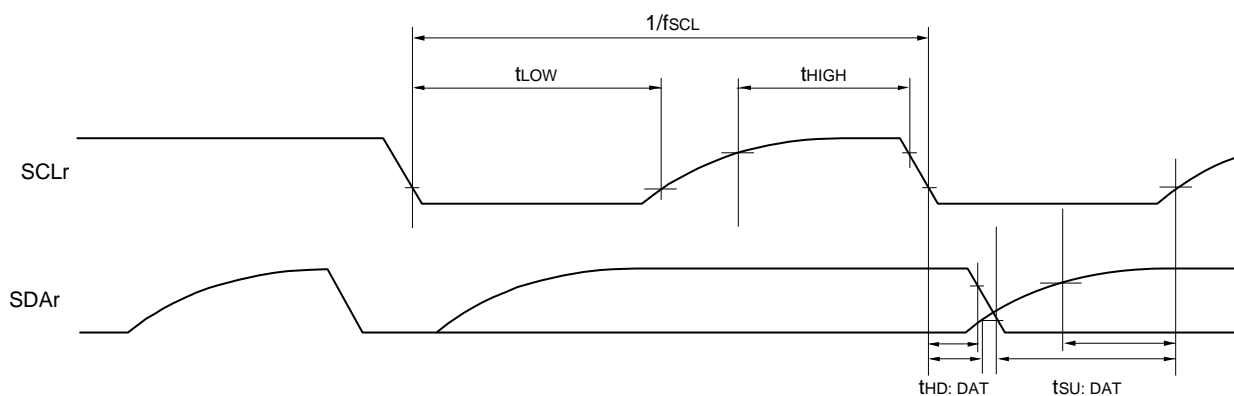

- Remark 1.** $R_b[\Omega]$: Communication line (SDAr, SCLr) pull-up resistance, $C_b[F]$: Communication line (SDAr, SCLr) load capacitance, $V_b[V]$: Communication line voltage
- Remark 2.** r: IIC number (r = 00, 01), g: PIM and POM numbers (g = 5)
- Remark 3.** f_{mck} : Serial array unit operation clock frequency
(Operation clock to be set by the CKSmn bit of serial mode register mn (SMRmn). m: Unit number (m = 0), n: Channel number (n = 0, 1), mn = 00, 01)

2.6 Analog Characteristics

2.6.1 A/D converter characteristics

Classification of A/D converter characteristics

Reference Voltage Input Channel	Reference voltage (+) = AV_{REFP} Reference voltage (-) = AV_{REFM}	Reference voltage (+) = AV_{DD} Reference voltage (-) = AV_{SS}	Reference voltage (+) = Internal reference voltage Reference voltage (-) = AV_{SS}
High-accuracy channel; ANI0 to ANI13 (input buffer power supply: AV_{DD})	Refer to 2.6.1 (1) . Refer to 2.6.1 (7) .	Refer to 2.6.1 (2) . Refer to 2.6.1 (7) .	Refer to 2.6.1 (5) . Refer to 2.6.1 (10) .
Standard channel; ANI16 to ANI18 (input buffer power supply: V_{DD})	Refer to 2.6.1 (3) . Refer to 2.6.1 (8) .	Refer to 2.6.1 (4) . Refer to 2.6.1 (9) .	
Internal reference voltage, Temperature sensor output voltage	Refer to 2.6.1 (3) . Refer to 2.6.1 (8) .	Refer to 2.6.1 (4) . Refer to 2.6.1 (9) .	—

(1) When reference voltage (+) = $AV_{REFP}/ANI0$ ($ADREFP1 = 0$, $ADREFP0 = 1$), reference voltage (-) = $AV_{REFM}/ANI1$ ($ADREFM = 1$), conversion target: ANI2 to ANI13

($T_A = -40$ to $+85^\circ\text{C}$, $1.6\text{ V} \leq AV_{REFP} \leq AV_{DD} = V_{DD} \leq 3.6\text{ V}$, $V_{SS} = 0\text{ V}$, $AV_{SS} = 0\text{ V}$, Reference voltage (+) = AV_{REFP} , Reference voltage (-) = $AV_{REFM} = 0\text{ V}$)

Parameter	Symbol	Conditions		MIN.	TYP.	MAX.	Unit
Resolution	RES		$2.4\text{ V} \leq AV_{REFP} \leq AV_{DD} \leq 3.6\text{ V}$	8		12	bit
			$1.8\text{ V} \leq AV_{REFP} \leq AV_{DD} \leq 3.6\text{ V}$	8		10 Note 1	
			$1.6\text{ V} \leq AV_{REFP} \leq AV_{DD} \leq 3.6\text{ V}$	8 Note 2			
Overall error Note 3	AINL	12-bit resolution	$2.4\text{ V} \leq AV_{REFP} \leq AV_{DD} \leq 3.6\text{ V}$			± 6.0	LSB
		10-bit resolution	$1.8\text{ V} \leq AV_{REFP} \leq AV_{DD} \leq 3.6\text{ V}$			± 5.0	
		8-bit resolution	$1.6\text{ V} \leq AV_{REFP} \leq AV_{DD} \leq 3.6\text{ V}$			± 2.5	
Conversion time	tCONV	ADTYP = 0, 12-bit resolution	$2.4\text{ V} \leq AV_{REFP} \leq AV_{DD} \leq 3.6\text{ V}$	3.375			μs
		ADTYP = 0, 10-bit resolution Note 1	$1.8\text{ V} \leq AV_{REFP} \leq AV_{DD} \leq 3.6\text{ V}$	6.75			
		ADTYP = 0, 8-bit resolution Note 2	$1.6\text{ V} \leq AV_{REFP} \leq AV_{DD} \leq 3.6\text{ V}$	13.5			
		ADTYP = 1, 8-bit resolution	$2.4\text{ V} \leq AV_{REFP} \leq AV_{DD} \leq 3.6\text{ V}$	2.5625			
			$1.8\text{ V} \leq AV_{REFP} \leq AV_{DD} \leq 3.6\text{ V}$	5.125			
	$1.6\text{ V} \leq AV_{REFP} \leq AV_{DD} \leq 3.6\text{ V}$	10.25					
Zero-scale error Note 3	Ezs	12-bit resolution	$2.4\text{ V} \leq AV_{REFP} \leq AV_{DD} \leq 3.6\text{ V}$			± 4.5	LSB
		10-bit resolution	$1.8\text{ V} \leq AV_{REFP} \leq AV_{DD} \leq 3.6\text{ V}$			± 4.5	
		8-bit resolution	$1.6\text{ V} \leq AV_{REFP} \leq AV_{DD} \leq 3.6\text{ V}$			± 2.0	
Full-scale error Note 3	EFS	12-bit resolution	$2.4\text{ V} \leq AV_{REFP} \leq AV_{DD} \leq 3.6\text{ V}$			± 4.5	LSB
		10-bit resolution	$1.8\text{ V} \leq AV_{REFP} \leq AV_{DD} \leq 3.6\text{ V}$			± 4.5	
		8-bit resolution	$1.6\text{ V} \leq AV_{REFP} \leq AV_{DD} \leq 3.6\text{ V}$			± 2.0	
Integral linearity error Note 3	ILE	12-bit resolution	$2.4\text{ V} \leq AV_{REFP} \leq AV_{DD} \leq 3.6\text{ V}$			± 2.0	LSB
		10-bit resolution	$1.8\text{ V} \leq AV_{REFP} \leq AV_{DD} \leq 3.6\text{ V}$			± 1.5	
		8-bit resolution	$1.6\text{ V} \leq AV_{REFP} \leq AV_{DD} \leq 3.6\text{ V}$			± 1.0	
Differential linearity error Note 3	DLE	12-bit resolution	$2.4\text{ V} \leq AV_{REFP} \leq AV_{DD} \leq 3.6\text{ V}$			± 1.5	LSB
		10-bit resolution	$1.8\text{ V} \leq AV_{REFP} \leq AV_{DD} \leq 3.6\text{ V}$			± 1.5	
		8-bit resolution	$1.6\text{ V} \leq AV_{REFP} \leq AV_{DD} \leq 3.6\text{ V}$			± 1.0	
Analog input voltage	VAIN			0		AV_{REFP}	V

Note 1. Cannot be used for lower 2 bit of ADCR register

Note 2. Cannot be used for lower 4 bit of ADCR register

Note 3. Excludes quantization error ($\pm 1/2$ LSB).

Caution Always use AV_{DD} pin with the same potential as the V_{DD} pin.

(2) When reference voltage (+) = AV_{DD} (ADREFP1 = 0, ADREFP0 = 0), reference voltage (-) = AV_{SS} (ADREFM = 0), conversion target: ANI0 to ANI13

(T_A = -40 to +85°C, 1.6 V ≤ AV_{DD} = V_{DD} ≤ 3.6 V, V_{SS} = 0 V, AV_{SS} = 0 V, Reference voltage (+) = AV_{DD}, Reference voltage (-) = AV_{SS} = 0 V)

Parameter	Symbol	Conditions		MIN.	TYP.	MAX.	Unit
Resolution	RES		2.4 V ≤ AV _{DD} ≤ 3.6 V	8		12	bit
			1.8 V ≤ AV _{DD} ≤ 3.6 V	8		10 Note 1	
			1.6 V ≤ AV _{DD} ≤ 3.6 V	8 Note 2			
Overall error Note 3	AINL	12-bit resolution	2.4 V ≤ AV _{DD} ≤ 3.6 V			±7.5	LSB
		10-bit resolution	1.8 V ≤ AV _{DD} ≤ 3.6 V			±5.5	
		8-bit resolution	1.6 V ≤ AV _{DD} ≤ 3.6 V			±3.0	
Conversion time	t _{CONV}	ADTYP = 0, 12-bit resolution	2.4 V ≤ AV _{DD} ≤ 3.6 V	3.375			μs
		ADTYP = 0, 10-bit resolution Note 1	1.8 V ≤ AV _{DD} ≤ 3.6 V	6.75			
		ADTYP = 0, 8-bit resolution Note 2	1.6 V ≤ AV _{DD} ≤ 3.6 V	13.5			
		ADTYP = 1, 8-bit resolution	2.4 V ≤ AV _{DD} ≤ 3.6 V	2.5625			
			1.8 V ≤ AV _{DD} ≤ 3.6 V	5.125			
	1.6 V ≤ AV _{DD} ≤ 3.6 V	10.25					
Zero-scale error Note 3	E _{ZS}	12-bit resolution	2.4 V ≤ AV _{DD} ≤ 3.6 V			±6.0	LSB
		10-bit resolution	1.8 V ≤ AV _{DD} ≤ 3.6 V			±5.0	
		8-bit resolution	1.6 V ≤ AV _{DD} ≤ 3.6 V			±2.5	
Full-scale error Note 3	E _{FS}	12-bit resolution	2.4 V ≤ AV _{DD} ≤ 3.6 V			±6.0	LSB
		10-bit resolution	1.8 V ≤ AV _{DD} ≤ 3.6 V			±5.0	
		8-bit resolution	1.6 V ≤ AV _{DD} ≤ 3.6 V			±2.5	
Integral linearity error Note 3	ILE	12-bit resolution	2.4 V ≤ AV _{DD} ≤ 3.6 V			±3.0	LSB
		10-bit resolution	1.8 V ≤ AV _{DD} ≤ 3.6 V			±2.0	
		8-bit resolution	1.6 V ≤ AV _{DD} ≤ 3.6 V			±1.5	
Differential linearity error Note 3	DLE	12-bit resolution	2.4 V ≤ AV _{DD} ≤ 3.6 V			±2.0	LSB
		10-bit resolution	1.8 V ≤ AV _{DD} ≤ 3.6 V			±2.0	
		8-bit resolution	1.6 V ≤ AV _{DD} ≤ 3.6 V			±1.5	
Analog input voltage	V _{AIN}	ANI0 to ANI6		0		AV _{DD}	V

Note 1. Cannot be used for lower 2 bit of ADCR register

Note 2. Cannot be used for lower 4 bit of ADCR register

Note 3. Excludes quantization error (±1/2 LSB).

Caution Always use AV_{DD} pin with the same potential as the V_{DD} pin.

(3) When reference voltage (+) = $AV_{REFP}/ANI0$ ($ADREFP1 = 0, ADREFP0 = 1$), reference voltage (-) = $AV_{REFM}/ANI1$ ($ADREFM = 1$), conversion target: ANI16 to ANI18, internal reference voltage, temperature sensor output voltage

($T_A = -40$ to $+85^\circ\text{C}$, $1.6\text{ V} \leq V_{DD} \leq 3.6\text{ V}$, $1.6\text{ V} \leq AV_{REFP} \leq AV_{DD} = V_{DD} \leq 3.6\text{ V}$, $V_{SS} = 0\text{ V}$, $AV_{SS} = 0\text{ V}$,

Reference voltage (+) = AV_{REFP} , Reference voltage (-) = $AV_{REFM} = 0\text{ V}$)

Parameter	Symbol	Conditions		MIN.	TYP.	MAX.	Unit
Resolution	RES		$2.4\text{ V} \leq AV_{REFP} \leq AV_{DD} \leq 3.6\text{ V}$	8		12	bit
			$1.8\text{ V} \leq AV_{REFP} \leq AV_{DD} \leq 3.6\text{ V}$	8		10 Note 1	
			$1.6\text{ V} \leq AV_{REFP} \leq AV_{DD} \leq 3.6\text{ V}$	8 Note 2			
Overall error Note 3	AINL	12-bit resolution	$2.4\text{ V} \leq AV_{REFP} \leq AV_{DD} \leq 3.6\text{ V}$			± 7.0	LSB
		10-bit resolution	$1.8\text{ V} \leq AV_{REFP} \leq AV_{DD} \leq 3.6\text{ V}$			± 5.5	
		8-bit resolution	$1.6\text{ V} \leq AV_{REFP} \leq AV_{DD} \leq 3.6\text{ V}$			± 3.0	
Conversion time	tCONV	ADTYP = 0, 12-bit resolution	$2.4\text{ V} \leq AV_{REFP} \leq AV_{DD} \leq 3.6\text{ V}$	4.125			μs
		ADTYP = 0, 10-bit resolution Note 1	$1.8\text{ V} \leq AV_{REFP} \leq AV_{DD} \leq 3.6\text{ V}$	9.5			
		ADTYP = 0, 8-bit resolution Note 2	$1.6\text{ V} \leq AV_{REFP} \leq AV_{DD} \leq 3.6\text{ V}$	57.5			
		ADTYP = 1, 8-bit resolution	$2.4\text{ V} \leq AV_{REFP} \leq AV_{DD} \leq 3.6\text{ V}$	3.3125			
			$1.8\text{ V} \leq AV_{REFP} \leq AV_{DD} \leq 3.6\text{ V}$	7.875			
	$1.6\text{ V} \leq AV_{REFP} \leq AV_{DD} \leq 3.6\text{ V}$	54.25					
Zero-scale error Note 3	Ezs	12-bit resolution	$2.4\text{ V} \leq AV_{REFP} \leq AV_{DD} \leq 3.6\text{ V}$			± 5.0	LSB
		10-bit resolution	$1.8\text{ V} \leq AV_{REFP} \leq AV_{DD} \leq 3.6\text{ V}$			± 5.0	
		8-bit resolution	$1.6\text{ V} \leq AV_{REFP} \leq AV_{DD} \leq 3.6\text{ V}$			± 2.5	
Full-scale error Note 3	Efs	12-bit resolution	$2.4\text{ V} \leq AV_{REFP} \leq AV_{DD} \leq 3.6\text{ V}$			± 5.0	LSB
		10-bit resolution	$1.8\text{ V} \leq AV_{REFP} \leq AV_{DD} \leq 3.6\text{ V}$			± 5.0	
		8-bit resolution	$1.6\text{ V} \leq AV_{REFP} \leq AV_{DD} \leq 3.6\text{ V}$			± 2.5	
Integral linearity error Note 3	ILE	12-bit resolution	$2.4\text{ V} \leq AV_{REFP} \leq AV_{DD} \leq 3.6\text{ V}$			± 3.0	LSB
		10-bit resolution	$1.8\text{ V} \leq AV_{REFP} \leq AV_{DD} \leq 3.6\text{ V}$			± 2.0	
		8-bit resolution	$1.6\text{ V} \leq AV_{REFP} \leq AV_{DD} \leq 3.6\text{ V}$			± 1.5	
Differential linearity error Note 3	DLE	12-bit resolution	$2.4\text{ V} \leq AV_{REFP} \leq AV_{DD} \leq 3.6\text{ V}$			± 2.0	LSB
		10-bit resolution	$1.8\text{ V} \leq AV_{REFP} \leq AV_{DD} \leq 3.6\text{ V}$			± 2.0	
		8-bit resolution	$1.6\text{ V} \leq AV_{REFP} \leq AV_{DD} \leq 3.6\text{ V}$			± 1.5	
Analog input voltage	VAIN			0		AV_{REFP}	V
		Internal reference voltage ($1.8\text{ V} \leq V_{DD} \leq 3.6\text{ V}$)		V_{BGR} Note 4			
		Temperature sensor output voltage ($1.8\text{ V} \leq V_{DD} \leq 3.6\text{ V}$)		V_{TMP25} Note 4			

Note 1. Cannot be used for lower 2 bits of ADCR register

Note 2. Cannot be used for lower 4 bits of ADCR register

Note 3. Excludes quantization error ($\pm 1/2$ LSB).

Note 4. Refer to 2.6.2 Temperature sensor, internal reference voltage output characteristics.

Caution Always use AV_{DD} pin with the same potential as the V_{DD} pin.

(4) When reference voltage (+) = AVDD (ADREFP1 = 0, ADREFP0 = 0), reference voltage (-) = AVSS (ADREFM = 0), conversion target: ANI16 to ANI18, internal reference voltage, temperature sensor output voltage

(TA = -40 to +85°C, 1.6 V ≤ AVDD = VDD ≤ 3.6 V, VSS = 0 V, AVSS = 0 V, Reference voltage (+) = AVDD, Reference voltage (-) = AVSS = 0 V)

Parameter	Symbol	Conditions	MIN.	TYP.	MAX.	Unit
Resolution	RES	2.4 V ≤ AVDD ≤ 3.6 V	8		12	bit
		1.8 V ≤ AVDD ≤ 3.6 V	8		10 Note 1	
		1.6 V ≤ AVDD ≤ 3.6 V	8 Note 2			
Overall error Note 3	AINL	12-bit resolution	2.4 V ≤ AVDD ≤ 3.6 V		±8.5	LSB
		10-bit resolution	1.8 V ≤ AVDD ≤ 3.6 V		±6.0	
		8-bit resolution	1.6 V ≤ AVDD ≤ 3.6 V		±3.5	
Conversion time	tCONV	ADTYP = 0, 12-bit resolution	2.4 V ≤ AVDD ≤ 3.6 V	4.125		μs
		ADTYP = 0, 10-bit resolution Note 1	1.8 V ≤ AVDD ≤ 3.6 V	9.5		
		ADTYP = 0, 8-bit resolution Note 2	1.6 V ≤ AVDD ≤ 3.6 V	57.5		
		ADTYP = 1, 8-bit resolution	2.4 V ≤ AVDD ≤ 3.6 V	3.3125		
			1.8 V ≤ AVDD ≤ 3.6 V	7.875		
Zero-scale error Note 3	Ezs	12-bit resolution	2.4 V ≤ AVDD ≤ 3.6 V		±8.0	LSB
		10-bit resolution	1.8 V ≤ AVDD ≤ 3.6 V		±5.5	
		8-bit resolution	1.6 V ≤ AVDD ≤ 3.6 V		±3.0	
Full-scale error Note 3	EFS	12-bit resolution	2.4 V ≤ AVDD ≤ 3.6 V		±8.0	LSB
		10-bit resolution	1.8 V ≤ AVDD ≤ 3.6 V		±5.5	
		8-bit resolution	1.6 V ≤ AVDD ≤ 3.6 V		±3.0	
Integral linearity error Note 3	ILE	12-bit resolution	2.4 V ≤ AVDD ≤ 3.6 V		±3.5	LSB
		10-bit resolution	1.8 V ≤ AVDD ≤ 3.6 V		±2.5	
		8-bit resolution	1.6 V ≤ AVDD ≤ 3.6 V		±1.5	
Differential linearity error Note 3	DLE	12-bit resolution	2.4 V ≤ AVDD ≤ 3.6 V		±2.5	LSB
		10-bit resolution	1.8 V ≤ AVDD ≤ 3.6 V		±2.5	
		8-bit resolution	1.6 V ≤ AVDD ≤ 3.6 V		±2.0	
Analog input voltage	VAIN		0		AVDD	V
		Internal reference voltage (1.8 V ≤ VDD ≤ 3.6 V)	VBGR Note 4			
		Temperature sensor output voltage (1.8 V ≤ VDD ≤ 3.6 V)	VTMP25 Note 4			

Note 1. Cannot be used for lower 2 bits of ADCR register

Note 2. Cannot be used for lower 4 bits of ADCR register

Note 3. Excludes quantization error (±1/2 LSB).

Note 4. Refer to 2.6.2 Temperature sensor, internal reference voltage output characteristics.

Caution Always use AVDD pin with the same potential as the VDD pin.

- (5) When reference voltage (+) = Internal reference voltage (1.45 V) (ADREFP1 = 1, ADREFP0 = 0), reference voltage (-) = AVSS (ADREFM = 0), conversion target: ANI0 to ANI13, ANI16 to ANI18

(TA = -40 to +85°C, 1.8 V ≤ AVDD = VDD ≤ 3.6 V, VSS = 0 V, AVSS = 0 V, Reference voltage (+) = internal reference voltage, Reference voltage (-) = AVSS = 0 V)

Parameter	Symbol	Conditions	MIN.	TYP.	MAX.	Unit
Resolution	RES		8			bit
Conversion time	tCONV	8-bit resolution	16			μs
Zero-scale error ^{Note}	EZS	8-bit resolution			±4.0	LSB
Integral linearity error ^{Note}	ILE	8-bit resolution			±2.0	LSB
Differential linearity error ^{Note}	DLE	8-bit resolution			±2.5	LSB
Analog input voltage	VAIN		0		VBGR	V

Note Excludes quantization error (±1/2 LSB).

Caution Always use AVDD pin with the same potential as the VDD pin.

- (6) When reference voltage (+) = AVREFP/ANI0 (ADREFP1 = 0, ADREFP0 = 1), reference voltage (-) = AVREFM/ANI1 (ADREFM = 1), conversion target: ANI2 to ANI13

(TA = +85 to +105°C, 2.4 V ≤ AVREFP ≤ AVDD = VDD ≤ 3.6 V, VSS = 0 V, AVSS = 0 V, Reference voltage (+) = AVREFP, Reference voltage (-) = AVREFM = 0 V)

Parameter	Symbol	Conditions		MIN.	TYP.	MAX.	Unit
Resolution	RES		2.4 V ≤ AVREFP ≤ AVDD ≤ 3.6 V	8		12	bit
Overall error ^{Note}	AINL	12-bit resolution	2.4 V ≤ AVREFP ≤ AVDD ≤ 3.6 V			±6.0	LSB
Conversion time	tCONV	ADTYP = 0, 12-bit resolution	2.4 V ≤ AVREFP ≤ AVDD ≤ 3.6 V	3.375			μs
Zero-scale error ^{Note}	EZS	12-bit resolution	2.4 V ≤ AVREFP ≤ AVDD ≤ 3.6 V			±4.5	LSB
Full-scale error ^{Note}	EFS	12-bit resolution	2.4 V ≤ AVREFP ≤ AVDD ≤ 3.6 V			±4.5	LSB
Integral linearity error ^{Note}	ILE	12-bit resolution	2.4 V ≤ AVREFP ≤ AVDD ≤ 3.6 V			±2.0	LSB
Differential linearity error ^{Note}	DLE	12-bit resolution	2.4 V ≤ AVREFP ≤ AVDD ≤ 3.6 V			±1.5	LSB
Analog input voltage	VAIN			0		AVREFP	V

Note Excludes quantization error (±1/2 LSB).

Caution Always use AVDD pin with the same potential as the VDD pin.

(7) When reference voltage (+) = AV_{DD} (ADREFP1 = 0, ADREFP0 = 0), reference voltage (-) = AV_{SS} (ADREFM = 0), conversion target: ANI0 to ANI13

(T_A = +85 to +105°C, 2.4 V ≤ AV_{DD} = V_{DD} ≤ 3.6 V, V_{SS} = 0 V, AV_{SS} = 0 V, Reference voltage (+) = AV_{DD}, Reference voltage (-) = AV_{SS} = 0 V)

Parameter	Symbol	Conditions		MIN.	TYP.	MAX.	Unit
Resolution	RES		2.4 V ≤ AV _{DD} ≤ 3.6 V	8		12	bit
Overall error ^{Note}	AINL	12-bit resolution	2.4 V ≤ AV _{DD} ≤ 3.6 V			±7.5	LSB
Conversion time	t _{CONV}	ADTYP = 0, 12-bit resolution	2.4 V ≤ AV _{DD} ≤ 3.6 V	3.375			μs
Zero-scale error ^{Note}	E _{ZS}	12-bit resolution	2.4 V ≤ AV _{DD} ≤ 3.6 V			±6.0	LSB
Full-scale error ^{Note}	E _{FS}	12-bit resolution	2.4 V ≤ AV _{DD} ≤ 3.6 V			±6.0	LSB
Integral linearity error ^{Note}	ILE	12-bit resolution	2.4 V ≤ AV _{DD} ≤ 3.6 V			±3.0	LSB
Differential linearity error ^{Note}	DLE	12-bit resolution	2.4 V ≤ AV _{DD} ≤ 3.6 V			±2.0	LSB
Analog input voltage	V _{AIN}			0		AV _{DD}	V

Note Excludes quantization error (±1/2 LSB).

Caution Always use AV_{DD} pin with the same potential as the V_{DD} pin.

(8) When reference voltage (+) = $AV_{REFP}/ANI0$ ($ADREFP1 = 0$, $ADREFP0 = 1$), reference voltage (-) = $AV_{REFM}/ANI1$ ($ADREFM = 1$), conversion target ANI16 to ANI18, internal reference voltage, temperature sensor output voltage

($T_A = +85$ to $+105^\circ\text{C}$, $2.4\text{ V} \leq AV_{REFP} \leq AV_{DD} = V_{DD} \leq 3.6\text{ V}$, $V_{SS} = 0\text{ V}$, $AV_{SS} = 0\text{ V}$, Reference voltage (+) = AV_{REFP} , Reference voltage (-) = $AV_{REFM} = 0\text{ V}$)

Parameter	Symbol	Conditions		MIN.	TYP.	MAX.	Unit
Resolution	RES		$2.4\text{ V} \leq AV_{REFP} \leq AV_{DD} \leq 3.6\text{ V}$	8		12	bit
Overall error Note 1	AINL	12-bit resolution	$2.4\text{ V} \leq AV_{REFP} \leq AV_{DD} \leq 3.6\text{ V}$			± 7.0	LSB
Conversion time	tCONV	ADTYP = 0, 12-bit resolution	$2.4\text{ V} \leq AV_{REFP} \leq AV_{DD} \leq 3.6\text{ V}$	4.125			μs
Zero-scale error Note 1	EzS	12-bit resolution	$2.4\text{ V} \leq AV_{REFP} \leq AV_{DD} \leq 3.6\text{ V}$			± 5.0	LSB
Full-scale error Note 1	EFS	12-bit resolution	$2.4\text{ V} \leq AV_{REFP} \leq AV_{DD} \leq 3.6\text{ V}$			± 5.0	LSB
Integral linearity error Note 1	ILE	12-bit resolution	$2.4\text{ V} \leq AV_{REFP} \leq AV_{DD} \leq 3.6\text{ V}$			± 3.0	LSB
Differential linearity error Note 1	DLE	12-bit resolution	$2.4\text{ V} \leq AV_{REFP} \leq AV_{DD} \leq 3.6\text{ V}$			± 2.0	LSB
Analog input voltage	VAIN			0		AV_{REFP}	V
		Internal reference voltage ($2.4\text{ V} \leq V_{DD} \leq 3.6\text{ V}$)		V_{BGR} Note 2			
		Temperature sensor output voltage ($2.4\text{ V} \leq V_{DD} \leq 3.6\text{ V}$)		V_{TMP25} Note 2			

Note 1. Excludes quantization error ($\pm 1/2$ LSB).

Note 2. Refer to **2.6.2 Temperature sensor, internal reference voltage output characteristics**.

Caution Always use AV_{DD} pin with the same potential as the V_{DD} pin.

(9) When reference voltage (+) = AV_{DD} (ADREFP1 = 0, ADREFP0 = 0), reference voltage (-) = AV_{SS} (ADREFM = 0), conversion target: ANI16 to ANI18, internal reference voltage, temperature sensor output voltage

(T_A = +85 to +105°C, 2.4 V ≤ AV_{DD} = V_{DD} ≤ 3.6 V, V_{SS} = 0 V, AV_{SS} = 0 V, Reference voltage (+) = AV_{DD}, Reference voltage (-) = AV_{SS} = 0)

Parameter	Symbol	Conditions		MIN.	TYP.	MAX.	Unit
Resolution	RES		2.4 V ≤ AV _{DD} ≤ 3.6 V	8		12	bit
Overall error ^{Note 1}	AINL	12-bit resolution	2.4 V ≤ AV _{DD} ≤ 3.6 V			±8.5	LSB
Conversion time	tCONV	ADTYP = 0, 12-bit resolution	2.4 V ≤ AV _{DD} ≤ 3.6 V	4.125			μs
Zero-scale error ^{Note 1}	EzS	12-bit resolution	2.4 V ≤ AV _{DD} ≤ 3.6 V			±8.0	LSB
Full-scale error ^{Note 1}	EFS	12-bit resolution	2.4 V ≤ AV _{DD} ≤ 3.6 V			±8.0	LSB
Integral linearity error ^{Note 1}	ILE	12-bit resolution	2.4 V ≤ AV _{DD} ≤ 3.6 V			±3.5	LSB
Differential linearity error ^{Note 1}	DLE	12-bit resolution	2.4 V ≤ AV _{DD} ≤ 3.6 V			±2.5	LSB
Analog input voltage	V _{AIN}			0		AV _{DD}	V
		Internal reference voltage (2.4 V ≤ V _{DD} ≤ 3.6 V)		V _{BGR} ^{Note 2}			
		Temperature sensor output voltage (2.4 V ≤ V _{DD} ≤ 3.6 V)		V _{TMP25} ^{Note 2}			

Note 1. Excludes quantization error (±1/2 LSB).

Note 2. Refer to 2.6.2 Temperature sensor, internal reference voltage output characteristics.

Caution Always use AV_{DD} pin with the same potential as the V_{DD} pin.

(10) When reference voltage (+) = Internal reference voltage (1.45 V) (ADREFP1 = 1, ADREFP0 = 0), reference voltage (-) = AVSS (ADREFM = 0), conversion target: ANI0 to ANI13, ANI16 to ANI18

(TA = +85 to +105°C, 2.4 V ≤ VDD, 2.4 V ≤ AVDD = VDD ≤ 3.6 V, VSS = 0 V, AVSS = 0 V, Reference voltage (+) = internal reference voltage, Reference voltage (-) = AVSS = 0 V)

Parameter	Symbol	Conditions	MIN.	TYP.	MAX.	Unit
Resolution	RES		8			bit
Conversion time	tCONV	8-bit resolution	16.0			μs
Zero-scale error ^{Note}	EZS	8-bit resolution			±4.0	LSB
Integral linearity error ^{Note}	ILE	8-bit resolution			±2.0	LSB
Differential linearity error ^{Note}	DLE	8-bit resolution			±2.5	LSB
Analog input voltage	VAIN		0		VBGR	V

Note Excludes quantization error (±1/2 LSB).

Caution Always use AVDD pin with the same potential as the VDD pin.

2.6.2 Temperature sensor, internal reference voltage output characteristics

(TA = -40 to 85°C, 1.8 V ≤ AVDD = VDD ≤ 3.6 V, VSS = AVSS = 0 V)

(TA = +85 to 105°C, 2.4 V ≤ AVDD = VDD ≤ 3.6 V, VSS = AVSS = 0 V)

Parameter	Symbol	Conditions	MIN.	TYP.	MAX.	Unit
Temperature sensor output voltage	VTMPS25	Setting ADS register = 80H, TA = +25°C		1.05		V
Internal reference voltage	VBGR	Setting ADS register = 81H	1.38	1.45	1.50	V
Temperature coefficient	FVTMPS	Temperature sensor output voltage that depends on the temperature		-3.6		mV/°C
Operation stabilization wait time	tAMP	2.4 V ≤ VDD ≤ 3.6 V	5			μs
		1.8 V ≤ VDD < 2.4 V	10			

2.6.3 Comparator

(TA = -40 to +85°C, 1.6 V ≤ AVDD = VDD ≤ 3.6 V, VSS = AVSS = 0 V)

(TA = +85 to +105°C, 2.4 V ≤ AVDD = VDD ≤ 3.6 V, VSS = AVSS = 0 V)

Parameter	Symbol	Conditions	MIN.	TYP.	MAX.	Unit	
Input voltage range	lvref0	IVREF0 pin	0		VDD - 1.4 Note	V	
	lvref1	IVREF1 pin	1.4 Note		VDD	V	
	lvcmp	IVCMP0, IVCMP1 pins	-0.3		VDD + 0.3	V	
Output delay	td	AVDD = 3.0 V Input slew rate > 50 mV/μs	Comparator high-speed mode, standard mode			1.2	μs
			Comparator high-speed mode, window mode			2.0	μs
			Comparator low-speed mode, standard mode		3.0		μs
			Comparator low-speed mode, window mode		4		μs
Operation stabilization wait time	tcMP		100			μs	

Note In window mode, make sure that Vref1 - Vref0 ≥ 0.2 V.

2.6.4 Operational amplifier characteristics

(TA = -40 to +85°C, 1.8 V ≤ AVDD = VDD ≤ 3.6 V, VSS = AVSS = 0 V)

(TA = +85 to +105°C, 2.4 V ≤ AVDD = VDD ≤ 3.6 V, VSS = AVSS = 0 V)

Parameter	Symbol	Conditions	MIN.	TYP.	MAX.	Unit
Common mode input range	Vicm1	Low-power consumption mode	0.2		AVDD - 0.5	V
	Vicm2	High-speed mode	0.3		AVDD - 0.6	V
Output voltage range	Vo1	Low-power consumption mode	0.1		AVDD - 0.1	V
	Vo2	High-speed mode	0.1		AVDD - 0.1	V
Input offset voltage	Vioff		-10		10	mV
Open gain	Av		60	120		dB
Gain-bandwidth (GB) product	GBW1	Low-power consumption mode		0.04		MHz
	GBW2	High-speed mode		1.7		MHz
Phase margin	PM	CL = 20 pF	50			deg
Gain margin	GM	CL = 20 pF	10			dB
Equivalent input noise	Vnoise1	f = 1 kHz	Low-power consumption mode	230		nV/√Hz
	Vnoise2	f = 10 kHz		200		nV/√Hz
	Vnoise3	f = 1 kHz	High-speed mode	90		nV/√Hz
	Vnoise4	f = 2 kHz		70		nV/√Hz
Power supply reduction ratio	PSRR			90		dB
Common mode signal reduction ratio	CMRR			90		dB
Operation stabilization wait time	Tstd1	CL = 20 pF Only operational amplifier is activated ^{Note}	Low-power consumption mode	650		μs
	Tstd2		High-speed mode	13		μs
	Tstd3	CL = 20 pF Operational amplifier and reference current circuit are activated simultaneously	Low-power consumption mode	650		μs
	Tstd4		High-speed mode	13		μs
Settling time	Tset1	CL = 20 pF	Low-power consumption mode		750	μs
	Tset2		High-speed mode		13	μs
Slew rate	Tslew1	CL = 20 pF	Low-power consumption mode	0.02		V/μs
	Tslew2		High-speed mode	1.1		V/μs
Load current	Iload1	Low-power consumption mode	-100		100	μA
	Iload2	High-speed mode	-100		100	μA
Load capacitance	CL				20	pF

Note When the operational amplifier reference current circuit is activated in advance.

2.6.5 POR circuit characteristics

($T_A = -40$ to $+105^\circ\text{C}$, $V_{SS} = AV_{SS} = 0\text{ V}$)

Parameter	Symbol	Conditions	MIN.	TYP.	MAX.	Unit	
Detection voltage	V _{POR}	The power supply voltage is rising.	T _A = -40 to +85°C	1.47	1.51	1.55	V
			T _A = +85 to +105°C	1.45	1.51	1.57	V
	V _{PDR}	The power supply voltage is falling. Note 1	T _A = -40 to +85°C	1.46	1.50	1.54	V
			T _A = +85 to +105°C	1.44	1.50	1.56	V
Minimum pulse width Note 2	T _{PW1}	Other than STOP/SUB HALT/SUB RUN	T _A = +40 to +105°C	300			μs
	T _{PW2}	STOP/SUB HALT/SUB RUN	T _A = +40 to +105°C	300			μs

Note 1. However, when the operating voltage falls while the LVD is off, enter STOP mode, or enable the reset status using the external reset pin before the voltage falls below the operating voltage range shown in 2.4 AC Characteristics.

Note 2. Minimum time required for a POR reset when V_{DD} exceeds below V_{PDR}. This is also the minimum time required for a POR reset from when V_{DD} exceeds below 0.7 V to when V_{DD} exceeds V_{POR} while STOP mode is entered or the main system clock is stopped through setting bit 0 (HIOSTOP) and bit 7 (MSTOP) in the clock operation status control register (CSC).

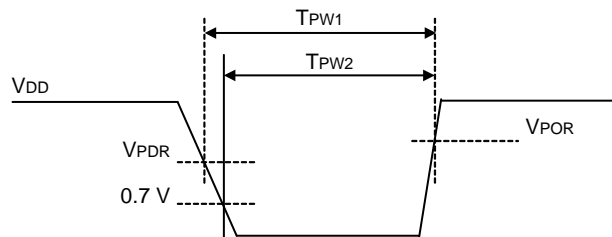

2.6.6 LVD circuit characteristics

(1) LVD Detection Voltage of Reset Mode and Interrupt Mode

(TA = -40 to +85°C, VPDR ≤ AVDD = VDD ≤ 3.6 V, VSS = AVSS = 0 V)

Parameter		Symbol	Conditions	MIN.	TYP.	MAX.	Unit
Detection voltage	Supply voltage level	VLVD2	The power supply voltage is rising.	3.07	3.13	3.19	V
			The power supply voltage is falling.	3.00	3.06	3.12	V
		VLVD3	The power supply voltage is rising.	2.96	3.02	3.08	V
			The power supply voltage is falling.	2.90	2.96	3.02	V
		VLVD4	The power supply voltage is rising.	2.86	2.92	2.97	V
			The power supply voltage is falling.	2.80	2.86	2.91	V
		VLVD5	The power supply voltage is rising.	2.76	2.81	2.87	V
			The power supply voltage is falling.	2.70	2.75	2.81	V
		VLVD6	The power supply voltage is rising.	2.66	2.71	2.76	V
			The power supply voltage is falling.	2.60	2.65	2.70	V
		VLVD7	The power supply voltage is rising.	2.56	2.61	2.66	V
			The power supply voltage is falling.	2.50	2.55	2.60	V
		VLVD8	The power supply voltage is rising.	2.45	2.50	2.55	V
			The power supply voltage is falling.	2.40	2.45	2.50	V
		VLVD9	The power supply voltage is rising.	2.05	2.09	2.13	V
			The power supply voltage is falling.	2.00	2.04	2.08	V
		VLVD10	The power supply voltage is rising.	1.94	1.98	2.02	V
			The power supply voltage is falling.	1.90	1.94	1.98	V
		VLVD11	The power supply voltage is rising.	1.84	1.88	1.91	V
			The power supply voltage is falling.	1.80	1.84	1.87	V
		VLVD12	The power supply voltage is rising.	1.74	1.77	1.81	V
			The power supply voltage is falling.	1.70	1.73	1.77	V
		VLVD13	The power supply voltage is rising.	1.64	1.67	1.70	V
			The power supply voltage is falling.	1.60	1.63	1.66	V
Minimum pulse width	tLW		300			μs	
Detection delay time					300	μs	

(TA = +85 to +105°C, VPDR ≤ AVDD = VDD ≤ 3.6 V, VSS = AVSS = 0 V)

Parameter		Symbol	Conditions	MIN.	TYP.	MAX.	Unit	
Detection voltage	Supply voltage level	VLVD2	The power supply voltage is rising.	3.01	3.13	3.25	V	
			The power supply voltage is falling.	2.94	3.06	3.18	V	
		VLVD3	The power supply voltage is rising.	2.90	3.02	3.14	V	
			The power supply voltage is falling.	2.85	2.96	3.07	V	
		VLVD4	The power supply voltage is rising.	2.81	2.92	3.03	V	
			The power supply voltage is falling.	2.75	2.86	2.97	V	
		VLVD5	The power supply voltage is rising.	2.71	2.81	2.92	V	
			The power supply voltage is falling.	2.64	2.75	2.86	V	
		VLVD6	The power supply voltage is rising.	2.61	2.71	2.81	V	
			The power supply voltage is falling.	2.55	2.65	2.75	V	
		VLVD7	The power supply voltage is rising.	2.51	2.61	2.71	V	
			The power supply voltage is falling.	2.45	2.55	2.65	V	
		Minimum pulse width	tLW		300			μs
		Detection delay time					300	μs

(2) LVD Detection Voltage of Interrupt & Reset Mode

(TA = -40 to +85°C, VPDR ≤ AVDD = VDD ≤ 3.6 V, VSS = AVSS = 0 V)

Parameter	Symbol	Conditions	MIN.	TYP.	MAX.	Unit	
Interrupt and reset mode	VLVDA0	VPOC0, VPOC1, VPOC2 = 0, 0, 0, falling reset voltage	1.60	1.63	1.66	V	
	VLVDA1	LVISO, LVIS1 = 1, 0	Rising release reset voltage	1.74	1.77	1.81	V
			Falling interrupt voltage	1.70	1.73	1.77	V
	VLVDA2	LVISO, LVIS1 = 0, 1	Rising release reset voltage	1.84	1.88	1.91	V
			Falling interrupt voltage	1.80	1.84	1.87	V
	VLVDA3	LVISO, LVIS1 = 0, 0	Rising release reset voltage	2.86	2.92	2.97	V
			Falling interrupt voltage	2.80	2.86	2.91	V
	VLVDB0	VPOC0, VPOC1, VPOC2 = 0, 0, 1, falling reset voltage	1.80	1.84	1.87	V	
	VLVDB1	LVISO, LVIS1 = 1, 0	Rising release reset voltage	1.94	1.98	2.02	V
			Falling interrupt voltage	1.90	1.94	1.98	V
	VLVDB2	LVISO, LVIS1 = 0, 1	Rising release reset voltage	2.05	2.09	2.13	V
			Falling interrupt voltage	2.00	2.04	2.08	V
	VLVDB3	LVISO, LVIS1 = 0, 0	Rising release reset voltage	3.07	3.13	3.19	V
			Falling interrupt voltage	3.00	3.06	3.12	V
	VLVDC0	VPOC0, VPOC1, VPOC2 = 0, 1, 0, falling reset voltage	2.40	2.45	2.50	V	
	VLVDC1	LVISO, LVIS1 = 1, 0	Rising release reset voltage	2.56	2.61	2.66	V
			Falling interrupt voltage	2.50	2.55	2.60	V
	VLVDC2	LVISO, LVIS1 = 0, 1	Rising release reset voltage	2.66	2.71	2.76	V
			Falling interrupt voltage	2.60	2.65	2.70	V
	VLVDD0	VPOC0, VPOC1, VPOC2 = 0, 1, 1, falling reset voltage	2.70	2.75	2.81	V	
VLVDD1	LVISO, LVIS1 = 1, 0	Rising release reset voltage	2.86	2.92	2.97	V	
		Falling interrupt voltage	2.80	2.86	2.91	V	
VLVDD2	LVISO, LVIS1 = 0, 1	Rising release reset voltage	2.96	3.02	3.08	V	
		Falling interrupt voltage	2.90	2.96	3.02	V	

(TA = +85 to +105°C, VPDR ≤ AVDD = VDD ≤ 3.6 V, VSS = AVSS = 0 V)

Parameter	Symbol	Conditions	MIN.	TYP.	MAX.	Unit	
Interrupt and reset mode	VLVDD0	VPOC0, VPOC1, VPOC2 = 0, 1, 1, falling reset voltage	2.64	2.75	2.86	V	
	VLVDD1	LVISO, LVIS1 = 1, 0	Rising release reset voltage	2.81	2.92	3.03	V
			Falling interrupt voltage	2.75	2.86	2.97	V
	VLVDD2	LVISO, LVIS1 = 0, 1	Rising release reset voltage	2.90	3.02	3.14	V
			Falling interrupt voltage	2.85	2.96	3.07	V

2.6.7 Power supply voltage rising slope characteristics

(TA = -40 to +105°C, VSS = AVSS = 0 V)

Parameter	Symbol	Conditions	MIN.	TYP.	MAX.	Unit
Power supply voltage rising slope	SVDD				54	V/ms

Caution Make sure to keep the internal reset state by the LVD circuit or an external reset until VDD reaches the operating voltage range shown in 2.4 AC Characteristics.

2.7 RAM Data Retention Characteristics

($T_A = -40$ to $+85^\circ\text{C}$, $1.8\text{ V} \leq AV_{DD} = V_{DD} \leq 3.6\text{ V}$, $V_{SS} = AV_{SS} = 0\text{ V}$)

($T_A = +85$ to $+105^\circ\text{C}$, $2.4\text{ V} \leq AV_{DD} = V_{DD} \leq 3.6\text{ V}$, $V_{SS} = AV_{SS} = 0\text{ V}$)

Parameter	Symbol	Conditions	MIN.	TYP.	MAX.	Unit
Data retention supply voltage	V _{DDDR}	T _A = -40 to +85°C	1.46 Note		3.6	V
		T _A = +85 to +105°C	1.44 Note		3.6	V

Note The value depends on the POR detection voltage. When the voltage drops, the data is retained before a POR reset is effected, but data is not retained when a POR reset is effected.

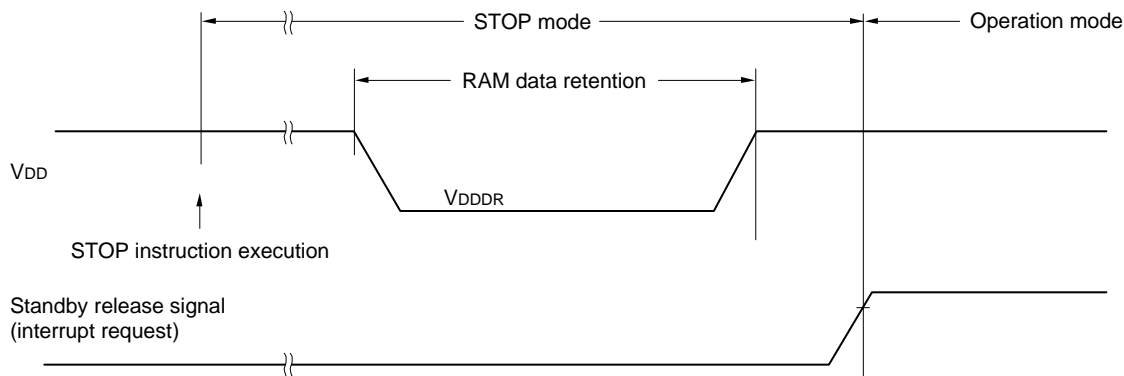

2.8 Flash Memory Programming Characteristics

($T_A = -40$ to $+85^\circ\text{C}$, $1.8\text{ V} \leq AV_{DD} = V_{DD} \leq 3.6\text{ V}$, $V_{SS} = AV_{SS} = 0\text{ V}$)

($T_A = +85$ to $+105^\circ\text{C}$, $2.4\text{ V} \leq AV_{DD} = V_{DD} \leq 3.6\text{ V}$, $V_{SS} = AV_{SS} = 0\text{ V}$)

Parameter	Symbol	Conditions	MIN.	TYP.	MAX.	Unit
System clock frequency	f _{CLK}		1		24	MHz
Number of code flash rewrites Notes 1, 2, 3	C _{erwr}	Retained for 20 years T _A = 85°C Note 4	1,000			Times
Number of data flash rewrites Notes 1, 2, 3		Retained for 1 year T _A = 25°C Note 4		1,000,000		
		Retained for 5 years T _A = 85°C Note 4	100,000			
		Retained for 20 years T _A = 85°C Note 4	10,000			

- Note 1.** 1 erase + 1 write after the erase is regarded as 1 rewrite. The retaining years are until next rewrite after the rewrite.
- Note 2.** When using flash memory programmer and Renesas Electronics self-programming library
- Note 3.** These are the characteristics of the flash memory and the results obtained from reliability testing by Renesas Electronics Corporation.
- Note 4.** This temperature is the average value at which data are retained.

2.9 Dedicated Flash Memory Programmer Communication (UART)

(TA = -40 to +85°C, 1.8 V ≤ AVDD = VDD ≤ 3.6 V, VSS = AVSS = 0 V)

(TA = +85 to +105°C, 2.4 V ≤ AVDD = VDD ≤ 3.6 V, VSS = AVSS = 0 V)

Parameter	Symbol	Conditions	MIN.	TYP.	MAX.	Unit
Transfer rate		During serial programming	115,200		1,000,000	bps

2.10 Timing of Entry to Flash Memory Programming Modes

(TA = -40 to +85°C, 1.8 V ≤ AVDD = VDD ≤ 3.6 V, VSS = AVSS = 0 V)

(TA = +85 to +105°C, 2.4 V ≤ AVDD = VDD ≤ 3.6 V, VSS = AVSS = 0 V)

Parameter	Symbol	Conditions	MIN.	TYP.	MAX.	Unit
How long from when an external reset ends until the initial communication settings are specified <small>Note 1</small>	tsUNIT	POR and LVD reset must end before the external reset ends.			100	ms
How long from when the TOOL0 pin is placed at the low level until an external reset ends <small>Note 1</small>	tsU	POR and LVD reset must end before the external reset ends.	10			μs
How long the TOOL0 pin must be kept at the low level after an external reset ends (excluding the processing time of the firmware to control the flash memory) <small>Notes 1, 2</small>	tHD	POR and LVD reset must end before the external reset ends.	1			ms

Note 1. Deassertion of the POR and LVD reset signals must precede deassertion of the pin reset signal.

Note 2. This excludes the flash firmware processing time (723 μs).

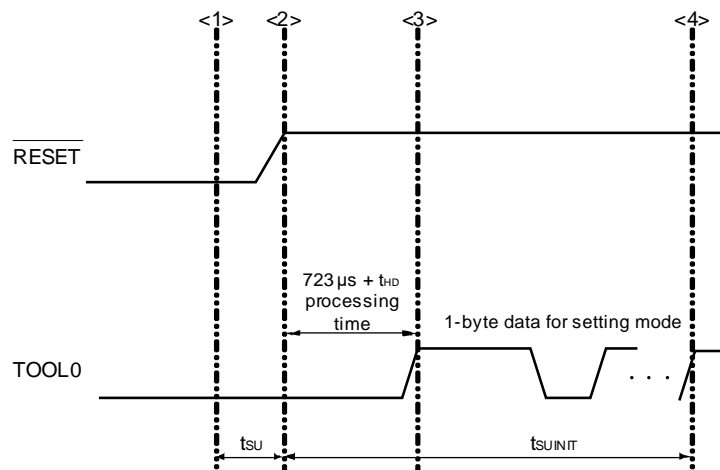

<1> The low level is input to the TOOL0 pin.

<2> The external reset ends (POR and LVD reset must end before the external reset ends).

<3> The TOOL0 pin is set to the high level.

<4> Setting of the flash memory programming mode by UART reception and complete the baud rate setting.

Remark tsUNIT: The segment shows that it is necessary to finish specifying the initial communication settings within 100 ms from when the external resets end.

tsU: How long from when the TOOL0 pin is placed at the low level until a pin reset ends

tHD: How long to keep the TOOL0 pin at the low level from when the external resets end (excluding the processing time of the firmware to control the flash memory)

3. PACKAGE DRAWINGS

3.1 20-pin package

JEITA Package Code	RENESAS Code	Previous Code	MASS (TYP.) [g]
P-LSSOP20-4.4x6.5-0.65	PLSP0020JB-A	P20MA-65-NAA-1	0.1

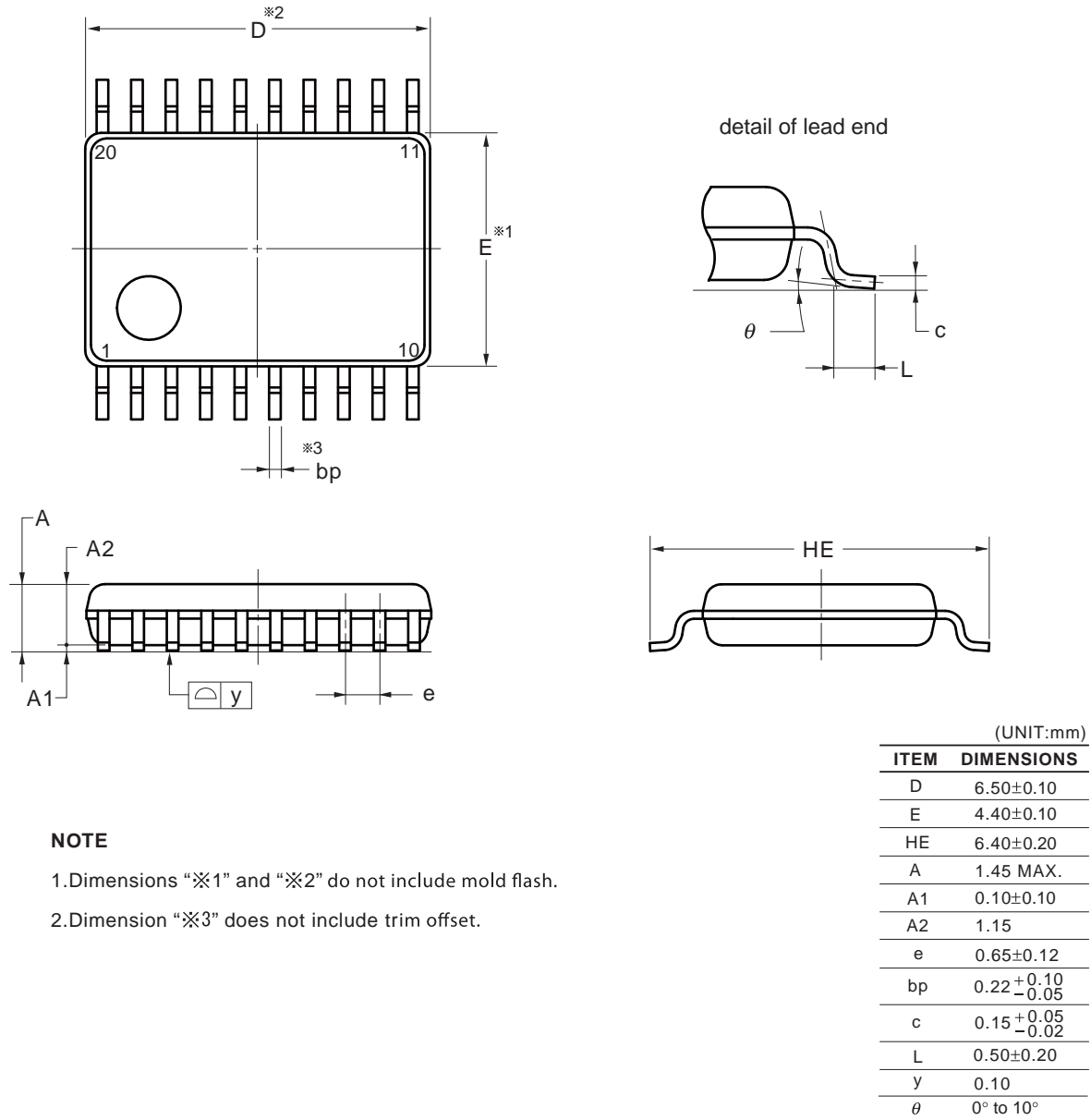

NOTE

1. Dimensions “ $\times 1$ ” and “ $\times 2$ ” do not include mold flash.
2. Dimension “ $\times 3$ ” does not include trim offset.

©2012 Renesas Electronics Corporation. All rights reserved.

JEITA Package code	RENESAS code	MASS(TYP.)[g]
P-TSSOP20-4.40x6.50-0.65	PTSP0020JI-A	0.08

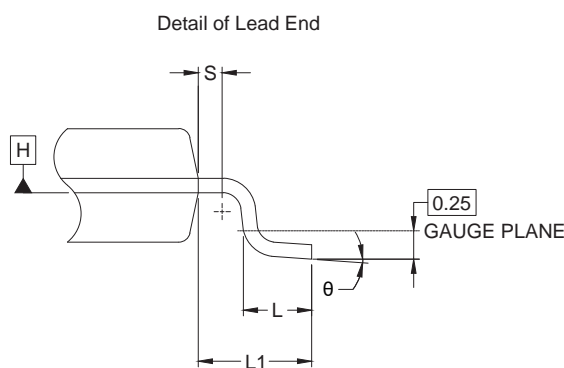
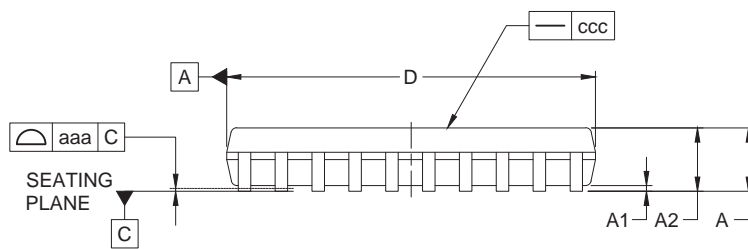
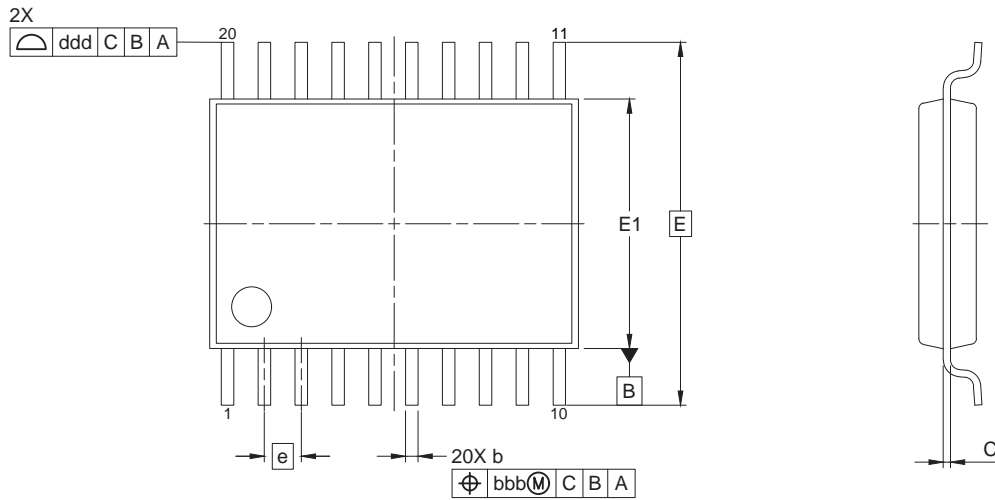

Reference Symbol	Dimension in Millimeters		
	Min.	Nom.	Max.
A	-	-	1.20
A1	0.05	-	0.15
A2	0.80	1.00	1.05
b	0.19	-	0.30
C	0.09	0.127	0.20
D	6.40	6.50	6.60
E1	4.30	4.40	4.50
E	6.40 BSC		
e	0.65 BSC		
L1	1.00 REF		
L	0.50	0.60	0.75
S	0.20	-	-
θ	0°	-	8°
aaa	0.10		
bbb	0.10		
ccc	0.05		
ddd	0.20		

NOTES:
 1.DIMENSION 'D' AND 'E1' DOES NOT INCLUDE MOLD FLASH.
 2.DIMENSION 'b' DOES NOT INCLUDE TRIM OFFSET.
 3.DIMENSION 'D' AND 'E1' TO BE DETERMINED AT DATUM PLANE \square .

3.2 24-pin package

JEITA Package code	RENESAS code	Previous code	MASS(TYP.)[g]
P-HWQFN24-4x4-0.50	PWQN0024KE-A	P24K8-50-CAB-3	0.04

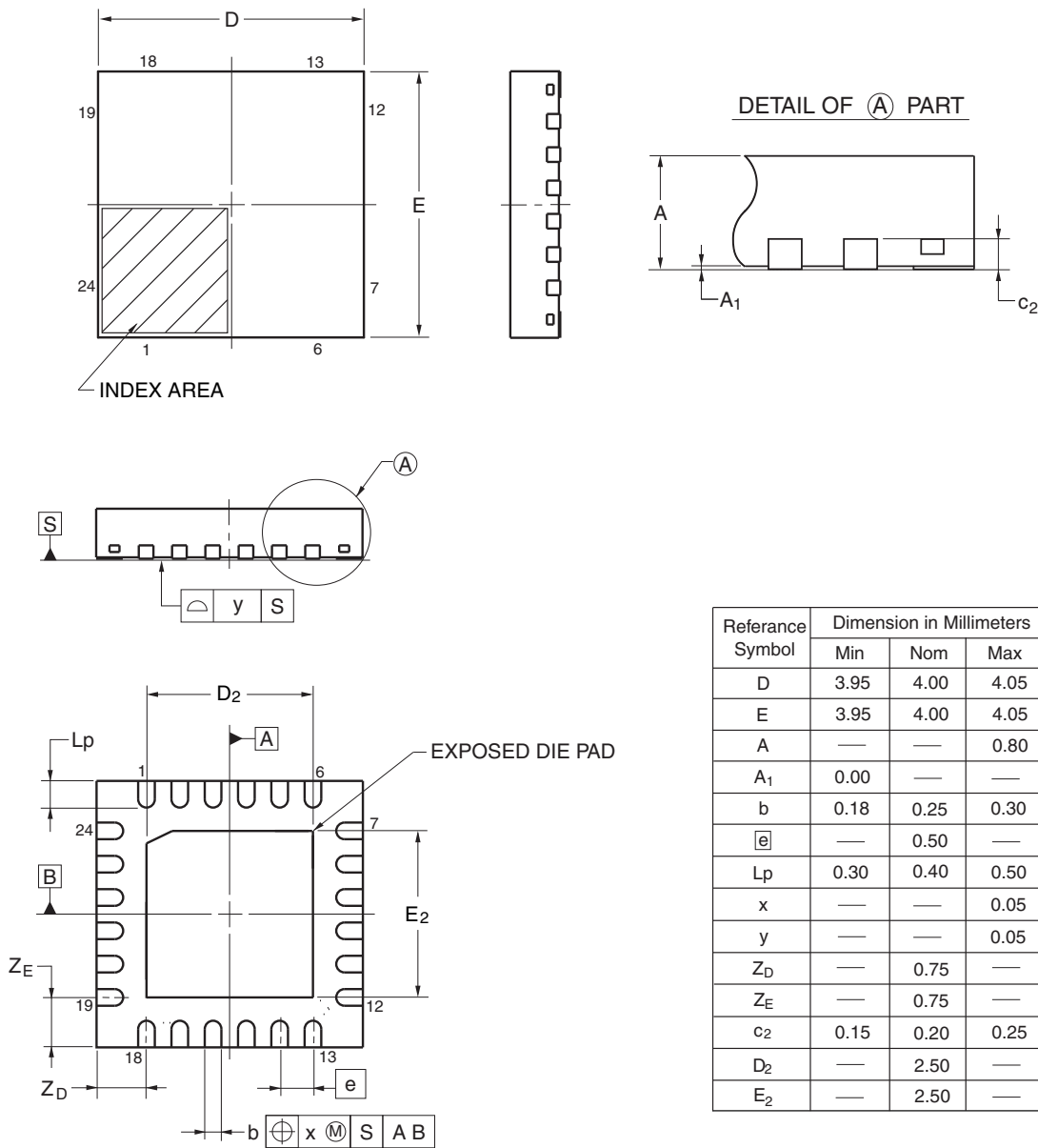

©2013 Renesas Electronics Corporation. All rights reserved.

JEITA Package code	RENESAS code	MASS(TYP.)[g]
P-HWQFN024-4x4-0.50	PWQN0024KF-A	0.04

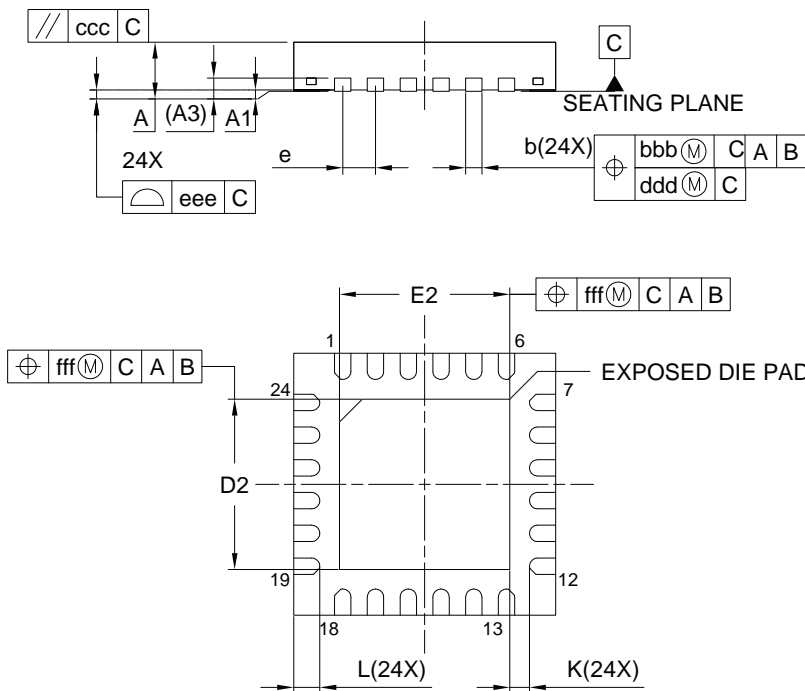
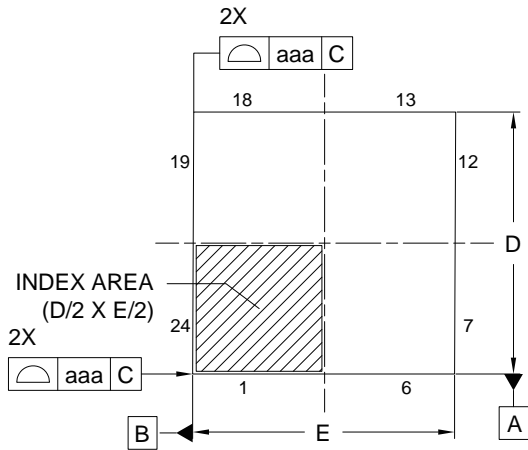

Reference Symbol	Dimension in Millimeters		
	Min.	Nom.	Max.
A	-	0.80	
A1	0.00	0.02	0.05
A3	0.203 REF.		
b	0.18	0.25	0.30
D	4.00 BSC		
E	4.00 BSC		
e	0.50 BSC		
L	0.35	0.40	0.45
K	0.20	-	-
D2	2.55	2.60	2.65
E2	2.55	2.60	2.65
aaa	0.15		
bbb	0.10		
ccc	0.10		
ddd	0.05		
eee	0.08		
fff	0.10		

JEITA Package Code	RENESAS Code	MASS(Typ.)[g]
P-HWQFN24-4×4-0.50	PWQN0024KH-A	0.04

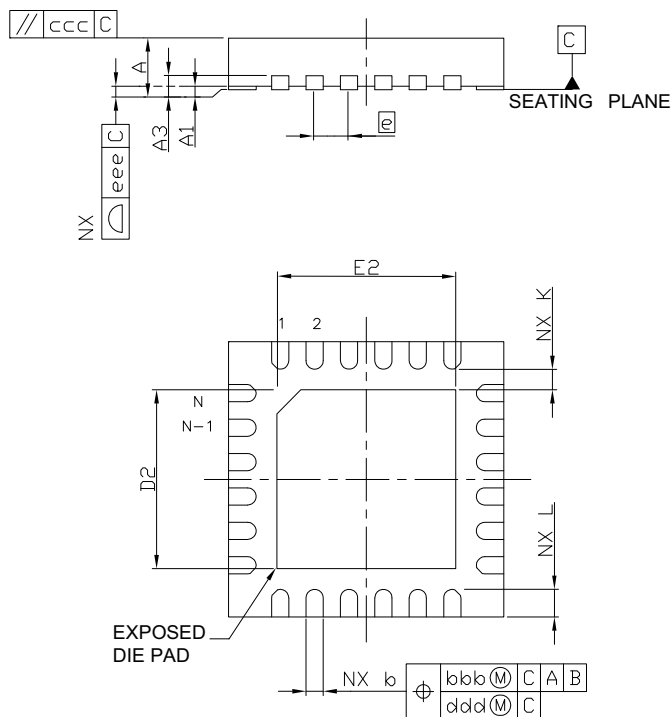
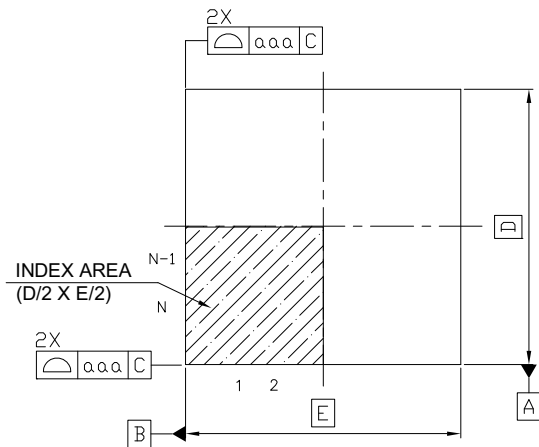

Reference Symbol	Dimension in Millimeters		
	Min.	Nom.	Max.
A	—	—	0.80
A ₁	0.00	—	0.05
A ₃	0.20 REF.		
b	0.20	0.25	0.30
D	—	4.00	—
E	—	4.00	—
e	—	0.50	—
N	24		
L	0.30	0.40	0.50
K	0.20	—	—
D ₂	2.50	2.60	2.70
E ₂	2.50	2.60	2.70
aaa	—	—	0.15
bbb	—	—	0.10
ccc	—	—	0.10
ddd	—	—	0.05
eee	—	—	0.08

3.3 30-pin package

JEITA Package Code	RENESAS Code	Previous Code	MASS (TYP.) [g]
P-LSSOP30-0300-0.65	PLSP0030JB-B	S30MC-65-5A4-3	0.18

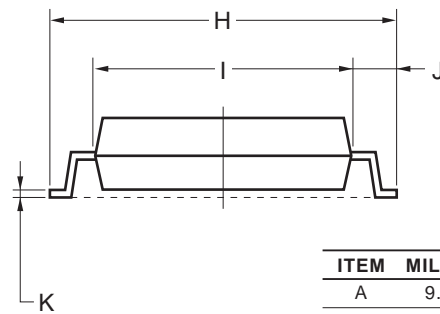
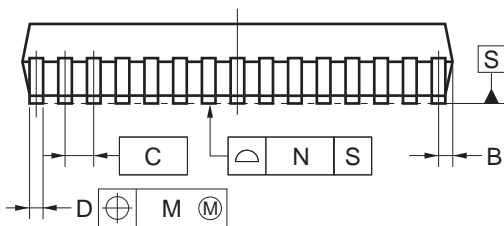
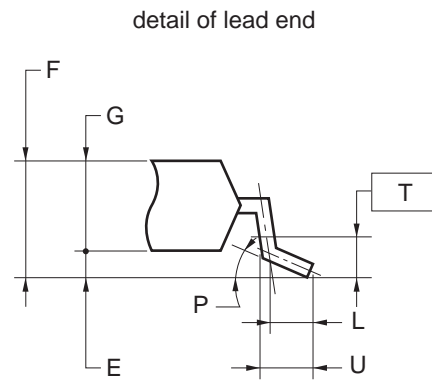
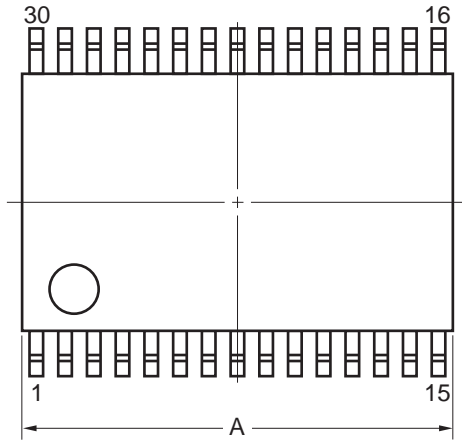

ITEM	MILLIMETERS
A	9.85±0.15
B	0.45 MAX.
C	0.65 (T.P.)
D	0.24 ^{+0.08} _{-0.07}
E	0.1±0.05
F	1.3±0.1
G	1.2
H	8.1±0.2
I	6.1±0.2
J	1.0±0.2
K	0.17±0.03
L	0.5
M	0.13
N	0.10
P	3° ^{+5°} _{-3°}
T	0.25
U	0.6±0.15

NOTE

Each lead centerline is located within 0.13 mm of its true position (T.P.) at maximum material condition.

3.4 32-pin package

JEITA Package code	RENESAS code	Previous code	MASS(TYP.)[g]
P-HVQFN32-5x5-0.50	PVQN0032KE-A	P32K9-50B-BAH	0.058

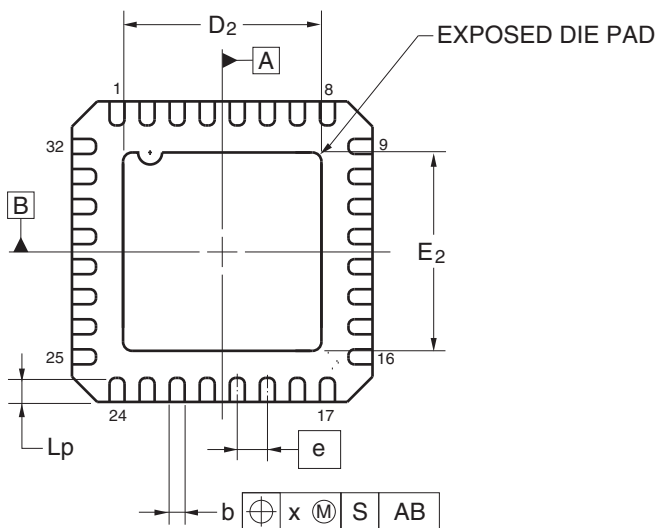
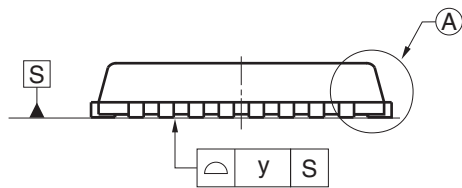
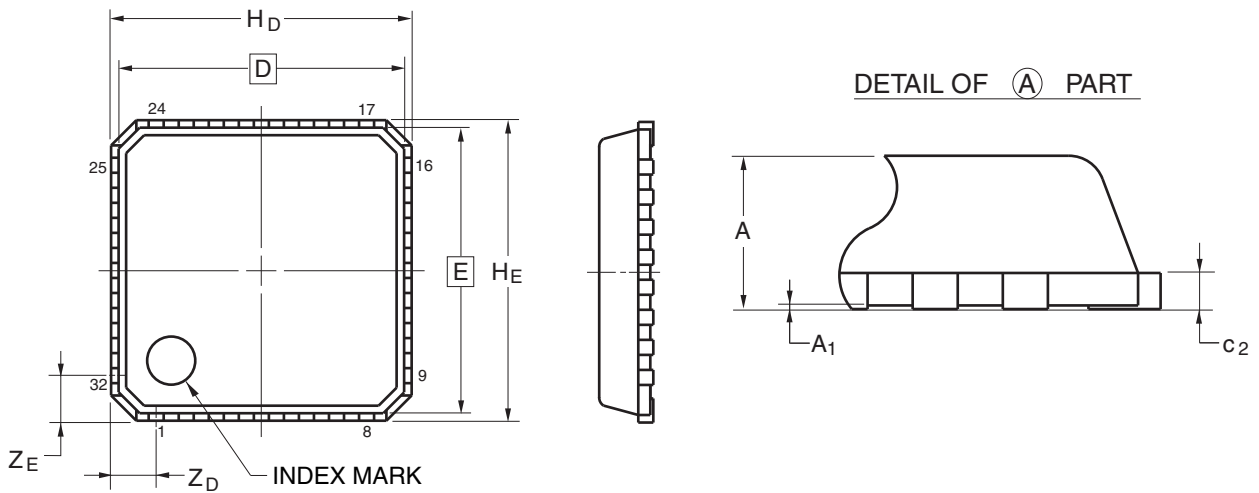

Reference Symbol	Dimension in Millimeters		
	Min	Nom	Max
D	—	4.75	—
E	—	4.75	—
A	—	—	0.90
A ₁	0.00	—	—
b	0.20	0.25	0.30
e	—	0.50	—
L _p	0.30	0.40	0.50
x	—	—	0.10
y	—	—	0.05
H _D	4.95	5.00	5.05
H _E	4.95	5.00	5.05
Z _D	—	0.75	—
Z _E	—	0.75	—
c ₂	0.19	0.20	0.21
D ₂	—	3.30	—
E ₂	—	3.30	—

JEITA Package Code	RENESAS Code	Previous Code	MASS (TYP) [g]
P-LQFP32-7x7-0.80	PLQP0032GB-A	P32GA-80-GBT-1	0.2

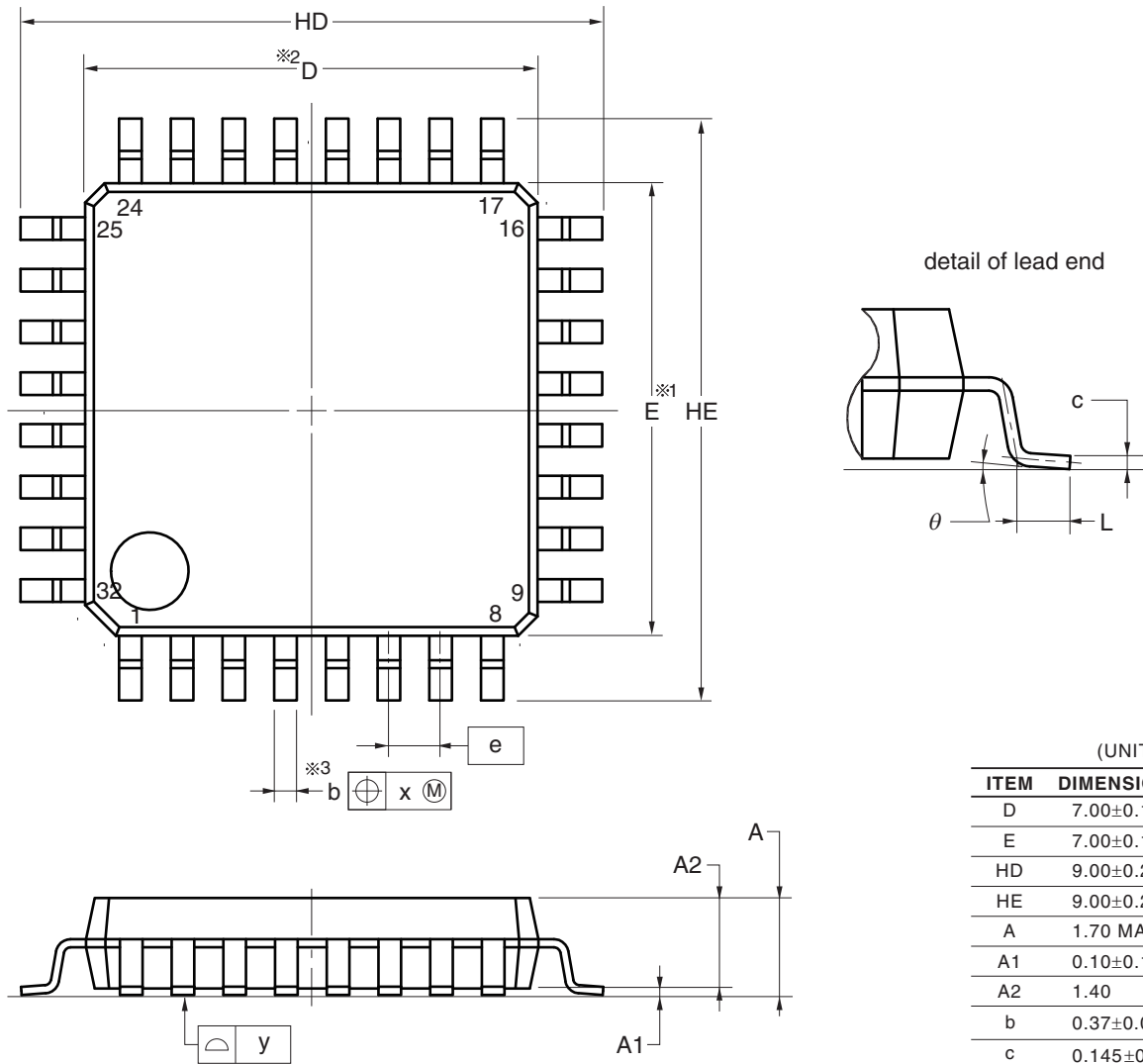

(UNIT:mm)

ITEM	DIMENSIONS
D	7.00±0.10
E	7.00±0.10
HD	9.00±0.20
HE	9.00±0.20
A	1.70 MAX.
A1	0.10±0.10
A2	1.40
b	0.37±0.05
c	0.145±0.055
L	0.50±0.20
θ	0° to 8°
e	0.80
x	0.20
y	0.10

NOTE

1. Dimensions “ $\ast 1$ ” and “ $\ast 2$ ” do not include mold flash.
2. Dimension “ $\ast 3$ ” does not include trim offset.

3.5 48-pin package

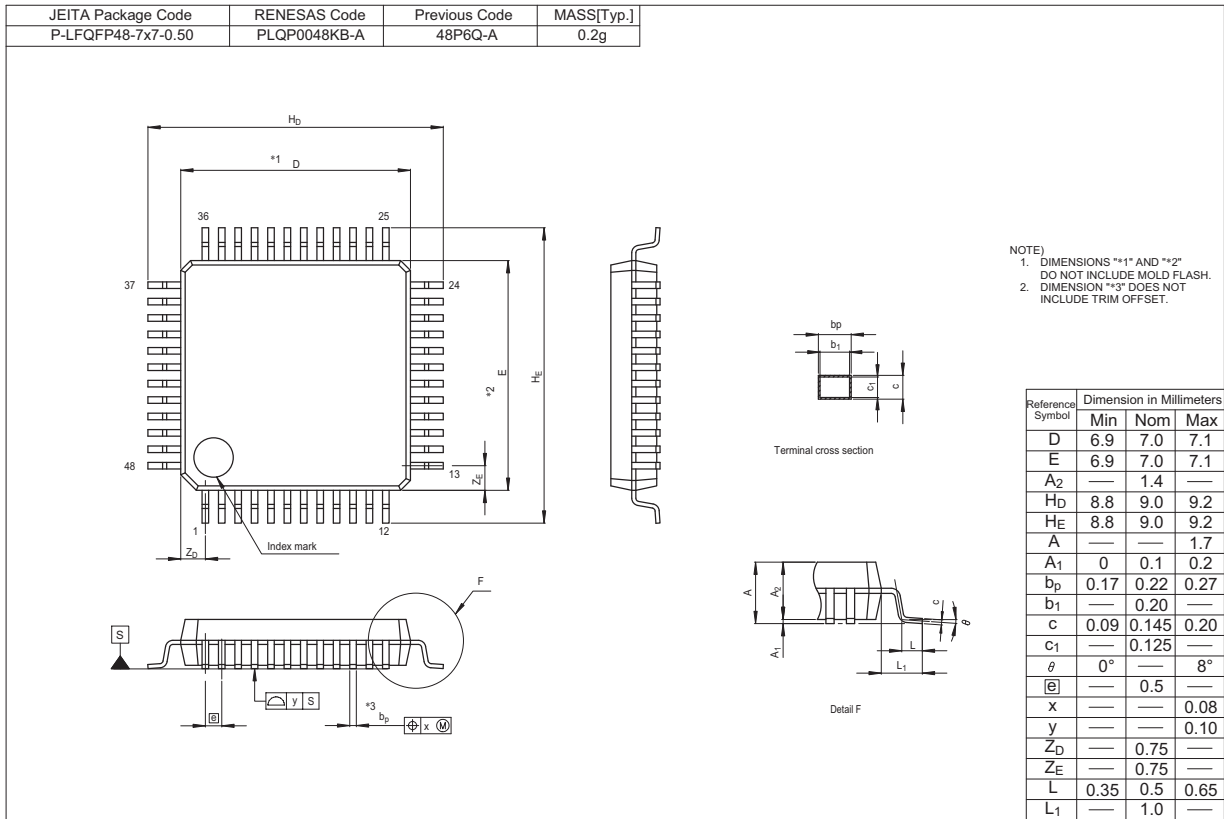

REVISION HISTORY

RL78/I1D Datasheet

Rev.	Date	Description	
		Page	Summary
1.00	Aug 29, 2014	—	First Edition issued
2.00	Jan 16, 2015	24, 25, 27	Addition of note 7 in 2.3.2 Supply current characteristics
		24, 26	Addition of description in 2.3.2 Supply current characteristics
		26, 28	Modification of description in 2.3.2 Supply current characteristics
		28	Correction of error in 2.3.2 Supply current characteristics
		95	Modification of package drawing in 3.2 24-pin products
2.20	Feb 20, 2017	ALL	The function name changed from real-time clock to real-time clock 2
		5	Addition of product name in 1.3.1 20-pin products
		6	Addition of product name in 1.3.2 24-pin products
		7	Addition of product name in 1.3.3 30-pin products
		8	Addition of product name in 1.3.4 32-pin products
		9	Change of description and addition of product name in 1.3.4 32-pin products
		10	Addition of product name in 1.3.5 48-pin products
		13, 14	Change of description in 1.6 Outline of Functions
		16	Change of 2.1 Absolute Maximum Ratings
		22	Change of 2.3.1 Pin characteristics
		24	Change of conditions in 2.3.2 Supply current characteristics
		25, 27, 28	Change of note 1 in 2.3.2 Supply current characteristics
		26	Change of conditions and unit in 2.3.2 Supply current characteristics
		30	Change of note 3 in 2.3.2 Supply current characteristics
		31	Addition of note 5 in 2.3.2 Supply current characteristics
		92	Change of table in 2.8 Flash Memory Programming Characteristics
		92	Addition of note 4 in 2.8 Flash Memory Programming Characteristics
99	Change of package drawing in 3.5 48-pin products		
2.30	Jun 30, 2020	1	Change of description in 1.1 Features
		3	Change of Figure 1 - 1 Part Number, Memory Size, and Package of RL78/I1D and addition of note 1
		4	Change of table in 1.2 Ordering Information
		5	Change of description in 1.3.1 20-pin products
		93	Change of the figure in 2.10 Timing of Entry to Flash Memory Programming Modes
		95	Addition of package drawing in 3.1 20-pin package
		97	Addition of package drawing in 3.2 24-pin package
2.40	Mar 20, 2023	ALL	"3-wire serial" was modified to "simplified SPI".
		2	1.1 Features: Note was added.
		5	1.2 Ordering Information: 24-pin RENESAS code was added.
		26	2.3.2 Supply current characteristics: Notes 1, 4, and 5 were modified.
		28	2.3.2 Supply current characteristics: Notes 1 and 5 were modified.
		29	2.3.2 Supply current characteristics: Note 1 was modified and note 2 was deleted.
		99	3.2 24-pin package: RENESAS code PWQN0024KH-A was added.

Rev.	Date	Description	
		Page	Summary
2.41	Mar 22, 2024	4	Change of description in Figure 1 - 1 Part Number, Memory Size, and Package of RL78/I1D
		5	Change of description in the table of 1.2 Ordering Information

SuperFlash is a registered trademark of Silicon Storage Technology, Inc. in several countries including the United States and Japan.

Caution: This product uses SuperFlash® technology licensed from Silicon Storage Technology, Inc.

All trademarks and registered trademarks are the property of their respective owners.

General Precautions in the Handling of Microprocessing Unit and Microcontroller Unit Products

The following usage notes are applicable to all Microprocessing unit and Microcontroller unit products from Renesas. For detailed usage notes on the products covered by this document, refer to the relevant sections of the document as well as any technical updates that have been issued for the products.

1. Precaution against Electrostatic Discharge (ESD)

A strong electrical field, when exposed to a CMOS device, can cause destruction of the gate oxide and ultimately degrade the device operation. Steps must be taken to stop the generation of static electricity as much as possible, and quickly dissipate it when it occurs. Environmental control must be adequate. When it is dry, a humidifier should be used. This is recommended to avoid using insulators that can easily build up static electricity. Semiconductor devices must be stored and transported in an anti-static container, static shielding bag or conductive material. All test and measurement tools including work benches and floors must be grounded. The operator must also be grounded using a wrist strap. Semiconductor devices must not be touched with bare hands. Similar precautions must be taken for printed circuit boards with mounted semiconductor devices.

2. Processing at power-on

The state of the product is undefined at the time when power is supplied. The states of internal circuits in the LSI are indeterminate and the states of register settings and pins are undefined at the time when power is supplied. In a finished product where the reset signal is applied to the external reset pin, the states of pins are not guaranteed from the time when power is supplied until the reset process is completed. In a similar way, the states of pins in a product that is reset by an on-chip power-on reset function are not guaranteed from the time when power is supplied until the power reaches the level at which resetting is specified.

3. Input of signal during power-off state

Do not input signals or an I/O pull-up power supply while the device is powered off. The current injection that results from input of such a signal or I/O pull-up power supply may cause malfunction and the abnormal current that passes in the device at this time may cause degradation of internal elements. Follow the guideline for input signal during power-off state as described in your product documentation.

4. Handling of unused pins

Handle unused pins in accordance with the directions given under handling of unused pins in the manual. The input pins of CMOS products are generally in the high-impedance state. In operation with an unused pin in the open-circuit state, extra electromagnetic noise is induced in the vicinity of the LSI, an associated shoot-through current flows internally, and malfunctions occur due to the false recognition of the pin state as an input signal become possible.

5. Clock signals

After applying a reset, only release the reset line after the operating clock signal becomes stable. When switching the clock signal during program execution, wait until the target clock signal is stabilized. When the clock signal is generated with an external resonator or from an external oscillator during a reset, ensure that the reset line is only released after full stabilization of the clock signal. Additionally, when switching to a clock signal produced with an external resonator or by an external oscillator while program execution is in progress, wait until the target clock signal is stable.

6. Voltage application waveform at input pin

Waveform distortion due to input noise or a reflected wave may cause malfunction. If the input of the CMOS device stays in the area between V_{IL} (Max.) and V_{IH} (Min.) due to noise, for example, the device may malfunction. Take care to prevent chattering noise from entering the device when the input level is fixed, and also in the transition period when the input level passes through the area between V_{IL} (Max.) and V_{IH} (Min.).

7. Prohibition of access to reserved addresses

Access to reserved addresses is prohibited. The reserved addresses are provided for possible future expansion of functions. Do not access these addresses as the correct operation of the LSI is not guaranteed.

8. Differences between products

Before changing from one product to another, for example to a product with a different part number, confirm that the change will not lead to problems. The characteristics of a microprocessing unit or microcontroller unit products in the same group but having a different part number might differ in terms of internal memory capacity, layout pattern, and other factors, which can affect the ranges of electrical characteristics, such as characteristic values, operating margins, immunity to noise, and amount of radiated noise. When changing to a product with a different part number, implement a system-evaluation test for the given product.

Notice

1. Descriptions of circuits, software and other related information in this document are provided only to illustrate the operation of semiconductor products and application examples. You are fully responsible for the incorporation or any other use of the circuits, software, and information in the design of your product or system. Renesas Electronics disclaims any and all liability for any losses and damages incurred by you or third parties arising from the use of these circuits, software, or information.
2. Renesas Electronics hereby expressly disclaims any warranties against and liability for infringement or any other claims involving patents, copyrights, or other intellectual property rights of third parties, by or arising from the use of Renesas Electronics products or technical information described in this document, including but not limited to, the product data, drawings, charts, programs, algorithms, and application examples.
3. No license, express, implied or otherwise, is granted hereby under any patents, copyrights or other intellectual property rights of Renesas Electronics or others.
4. You shall be responsible for determining what licenses are required from any third parties, and obtaining such licenses for the lawful import, export, manufacture, sales, utilization, distribution or other disposal of any products incorporating Renesas Electronics products, if required.
5. You shall not alter, modify, copy, or reverse engineer any Renesas Electronics product, whether in whole or in part. Renesas Electronics disclaims any and all liability for any losses or damages incurred by you or third parties arising from such alteration, modification, copying or reverse engineering.
6. Renesas Electronics products are classified according to the following two quality grades: "Standard" and "High Quality". The intended applications for each Renesas Electronics product depends on the product's quality grade, as indicated below.

"Standard": Computers; office equipment; communications equipment; test and measurement equipment; audio and visual equipment; home electronic appliances; machine tools; personal electronic equipment; industrial robots; etc.

"High Quality": Transportation equipment (automobiles, trains, ships, etc.); traffic control (traffic lights); large-scale communication equipment; key financial terminal systems; safety control equipment; etc.

Unless expressly designated as a high reliability product or a product for harsh environments in a Renesas Electronics data sheet or other Renesas Electronics document, Renesas Electronics products are not intended or authorized for use in products or systems that may pose a direct threat to human life or bodily injury (artificial life support devices or systems; surgical implantations; etc.), or may cause serious property damage (space system; undersea repeaters; nuclear power control systems; aircraft control systems; key plant systems; military equipment; etc.). Renesas Electronics disclaims any and all liability for any damages or losses incurred by you or any third parties arising from the use of any Renesas Electronics product that is inconsistent with any Renesas Electronics data sheet, user's manual or other Renesas Electronics document.

7. No semiconductor product is absolutely secure. Notwithstanding any security measures or features that may be implemented in Renesas Electronics hardware or software products, Renesas Electronics shall have absolutely no liability arising out of any vulnerability or security breach, including but not limited to any unauthorized access to or use of a Renesas Electronics product or a system that uses a Renesas Electronics product. RENESAS ELECTRONICS DOES NOT WARRANT OR GUARANTEE THAT RENESAS ELECTRONICS PRODUCTS, OR ANY SYSTEMS CREATED USING RENESAS ELECTRONICS PRODUCTS WILL BE INVULNERABLE OR FREE FROM CORRUPTION, ATTACK, VIRUSES, INTERFERENCE, HACKING, DATA LOSS OR THEFT, OR OTHER SECURITY INTRUSION ("Vulnerability Issues"). RENESAS ELECTRONICS DISCLAIMS ANY AND ALL RESPONSIBILITY OR LIABILITY ARISING FROM OR RELATED TO ANY VULNERABILITY ISSUES. FURTHERMORE, TO THE EXTENT PERMITTED BY APPLICABLE LAW, RENESAS ELECTRONICS DISCLAIMS ANY AND ALL WARRANTIES, EXPRESS OR IMPLIED, WITH RESPECT TO THIS DOCUMENT AND ANY RELATED OR ACCOMPANYING SOFTWARE OR HARDWARE, INCLUDING BUT NOT LIMITED TO THE IMPLIED WARRANTIES OF MERCHANTABILITY, OR FITNESS FOR A PARTICULAR PURPOSE.
8. When using Renesas Electronics products, refer to the latest product information (data sheets, user's manuals, application notes, "General Notes for Handling and Using Semiconductor Devices" in the reliability handbook, etc.), and ensure that usage conditions are within the ranges specified by Renesas Electronics with respect to maximum ratings, operating power supply voltage range, heat dissipation characteristics, installation, etc. Renesas Electronics disclaims any and all liability for any malfunctions, failure or accident arising out of the use of Renesas Electronics products outside of such specified ranges.
9. Although Renesas Electronics endeavors to improve the quality and reliability of Renesas Electronics products, semiconductor products have specific characteristics, such as the occurrence of failure at a certain rate and malfunctions under certain use conditions. Unless designated as a high reliability product or a product for harsh environments in a Renesas Electronics data sheet or other Renesas Electronics document, Renesas Electronics products are not subject to radiation resistance design. You are responsible for implementing safety measures to guard against the possibility of bodily injury, injury or damage caused by fire, and/or danger to the public in the event of a failure or malfunction of Renesas Electronics products, such as safety design for hardware and software, including but not limited to redundancy, fire control and malfunction prevention, appropriate treatment for aging degradation or any other appropriate measures. Because the evaluation of microcomputer software alone is very difficult and impractical, you are responsible for evaluating the safety of the final products or systems manufactured by you.
10. Please contact a Renesas Electronics sales office for details as to environmental matters such as the environmental compatibility of each Renesas Electronics product. You are responsible for carefully and sufficiently investigating applicable laws and regulations that regulate the inclusion or use of controlled substances, including without limitation, the EU RoHS Directive, and using Renesas Electronics products in compliance with all these applicable laws and regulations. Renesas Electronics disclaims any and all liability for damages or losses occurring as a result of your noncompliance with applicable laws and regulations.
11. Renesas Electronics products and technologies shall not be used for or incorporated into any products or systems whose manufacture, use, or sale is prohibited under any applicable domestic or foreign laws or regulations. You shall comply with any applicable export control laws and regulations promulgated and administered by the governments of any countries asserting jurisdiction over the parties or transactions.
12. It is the responsibility of the buyer or distributor of Renesas Electronics products, or any other party who distributes, disposes of, or otherwise sells or transfers the product to a third party, to notify such third party in advance of the contents and conditions set forth in this document.
13. This document shall not be reprinted, reproduced or duplicated in any form, in whole or in part, without prior written consent of Renesas Electronics.
14. Please contact a Renesas Electronics sales office if you have any questions regarding the information contained in this document or Renesas Electronics products.

(Note1) "Renesas Electronics" as used in this document means Renesas Electronics Corporation and also includes its directly or indirectly controlled subsidiaries.

(Note2) "Renesas Electronics product(s)" means any product developed or manufactured by or for Renesas Electronics.

(Rev.5.0-1 October 2020)

Corporate Headquarters

TOYOSU FORESIA, 3-2-24 Toyosu,
Koto-ku, Tokyo 135-0061, Japan
www.renesas.com

Trademarks

Renesas and the Renesas logo are trademarks of Renesas Electronics Corporation. All trademarks and registered trademarks are the property of their respective owners.

Contact Information

For further information on a product, technology, the most up-to-date version of a document, or your nearest sales office, please visit:
www.renesas.com/contact/