

RC32112A

FemtoClock Network Synchronizer, Jitter Attenuator and Clock Generator

The RC32112A is a fully integrated, low-power, high-performance network synchronizer, jitter attenuator and clock generator. The device supports JEDEC JESD204B/C for converter synchronization and SyncE for network-based synchronization.

The RC32112A is ideal for providing reference clocks for high-speed serial links up to 28Gbps Ethernet in modular switch line cards and fabric cards in data center equipment, and for clocking data converters in small-cell wireless equipment. The device is a member of Renesas' high-performance FemtoClock family and radio clock family.

Applications

- Switches / routers
- Network synchronization and jitter attenuation for 10 / 25 / 40 / 100 / 200 / 400 Gbps Ethernet PHYs in switch line cards
- Clock generation for 10 / 25 / 40 / 100 / 200 / 400 Gbps Ethernet PHYs in switch fabric cards
- Small-cell wireless equipment for 4.5G and 5G
- Medical imaging
- Professional audio and video

Product Options

- 10 × 10 × 0.9 mm 72-VFQFPN package
- 12 differential or 24 single-ended outputs

Features

- Can be configured as clock generator or jitter attenuator/synchronizer
- Low power, less than 1.4W typical
- Low jitter, less than 100 fs-RMS
- Compliant with ITU-T G.8262 and G.8262.1 option 1 and 2 for synchronous Ethernet Equipment Clock (EEC/eEEC) and G.8273.2 T-BC for synchronous Ethernet and PTP/IEEE 1588 telecom boundary clock
- PCIe Gen 1-6 CC, SRIS, and SRNS support
- Jitter attenuation with programmable loop bandwidth from 0.1Hz to 12kHz
- Up to six fractional output dividers and 12 integer output dividers
 - Each fractional output divider can be slaved with DPLL or SYS-DPLL or free-run locked to APLL
- DPLLs can be configured as DCO and each fractional output divider can be configured as NCO or DCO
- Combo bus allows frequency sharing between DPLLs, System DPLL, and each of the four fractional output dividers
- LVCMOS, LVPECL, LVDS, HCSL, CML, SSTL, HSTL output modes supported with programmable output swing and common mode voltage
- JESD204B/C support on differential or single ended outputs with DC-coupling or AC-coupling
- Up to 13 single-ended or five differential clock inputs, one crystal/XO input, and one XO/TCXO/OCXO input
- Up to nine GPIO pins programmable to device select or system monitor options
- Supports 1MHz I²C, 400kHz SMBus, or 50MHz SPI serial port
- Internal non-volatile memory (up to 16 different configurations), or external serial I²C EEPROM provide default device settings on power-up.
- 2.5V and 3.3V core and 1.8V, 2.5V, and 3.3V output operation
- -40° to +85°C industrial temperature operation

Contents

| | |
|---|-----------|
| 1. Overview | 5 |
| 1.1 Block Diagram | 5 |
| 1.2 Typical Applications | 6 |
| 2. Pin Information | 7 |
| 2.1 Pin Assignments | 7 |
| 2.2 Pin Descriptions | 7 |
| 2.3 Pin Characteristics | 10 |
| 3. Specifications | 11 |
| 3.1 Abbreviations Used | 11 |
| 3.2 Absolute Maximum Ratings | 11 |
| 3.3 Recommended Operating Conditions | 12 |
| 3.4 Supply Voltage Characteristics | 12 |
| 3.5 DC Electrical Characteristics | 15 |
| 3.6 AC Electrical Characteristics | 21 |
| 4. Functional Description | 30 |
| 4.1 Clock Generator Mode | 30 |
| 4.2 Jitter Attenuator or Synchronizer Mode | 30 |
| 4.3 Power-Up, Configuration and Serial Interfaces | 30 |
| 4.4 Input Clocks | 31 |
| 4.4.1 Crystal/Oscillator Input | 31 |
| 4.4.2 XO_DPLL Input | 31 |
| 4.4.3 Reference Clock Inputs | 31 |
| 4.5 Clock Input Monitors | 31 |
| 4.6 Clock Input Monitor | 31 |
| 4.7 APLL | 31 |
| 4.7.1 APLL Lock Detector | 31 |
| 4.8 System DPLL | 32 |
| 4.9 DPLL | 32 |
| 4.10 DPLL Operating Modes | 32 |
| 4.10.1 Free-Run Mode | 33 |
| 4.10.2 Locked Mode | 34 |
| 4.10.3 Holdover Mode | 34 |
| 4.10.4 Manual Holdover Mode | 35 |
| 4.11 DPLL Input Clock Qualification and Selection | 35 |
| 4.11.1 Automatic Input Clock Selection | 35 |
| 4.11.2 Manual Input Clock Selection via Register or GPIO | 35 |
| 4.11.3 Slave or GPIO Slave Selection | 35 |
| 4.12 DPLL Switchover Management | 35 |
| 4.12.1 Revertive and Non-Revertive Switching | 35 |
| 4.12.2 Hitless Reference Switching | 36 |
| 4.12.3 Phase Slope Limiting | 36 |
| 4.12.4 DPLL Frequency Offset Limit Setting | 36 |
| 4.12.5 DPLL Fast Lock Operation | 37 |
| 4.13 Digitally-Controlled Oscillator Operation via External Control | 37 |
| 4.13.1 Write-Frequency Mode | 38 |
| 4.13.2 Increment / Decrement Registers and Pins | 38 |

| | | |
|-----------|---|-----------|
| 4.13.3 | Write-Phase Mode | 39 |
| 4.13.4 | Adjusting Phase while in Closed Loop Operation | 40 |
| 4.14 | DPLL Lock Detector | 40 |
| 4.15 | Output Dividers | 40 |
| 4.15.1 | Integer Output Dividers | 40 |
| 4.15.2 | Fractional Output Dividers | 41 |
| 4.16 | Clock Outputs | 41 |
| 4.16.1 | Output Buffer in Single-Ended Mode | 42 |
| 4.16.2 | Output Buffer in Differential Mode | 42 |
| 4.16.3 | Output Banks | 42 |
| 4.17 | General Purpose Input/Outputs (GPIOs) | 43 |
| 4.17.1 | GPIO Modes | 43 |
| 4.17.2 | GPIO Pin Configuration | 44 |
| 4.17.3 | Alarm Output Operation | 44 |
| 4.18 | Temperature Sensor | 45 |
| 4.19 | Device Initial Configuration | 46 |
| 4.19.1 | Use of GPIO Pins at Reset | 46 |
| 4.19.2 | Default Values for Registers | 47 |
| 4.20 | One-Time Programmable (OTP) Memory | 47 |
| 4.20.1 | Configuration Data in OTP | 48 |
| 4.20.2 | Configuration Data in External I2C EEPROM | 48 |
| 4.21 | Reset Sequence | 49 |
| 4.21.1 | Step 0 – Reset Sequence Starting Condition | 49 |
| 4.21.2 | Step 1 – Negation of nMR (Rising Edge) | 49 |
| 4.21.3 | Step 2 – Internally Set Default Conditions | 49 |
| 4.21.4 | Step 3 – Scan for Device Updates in EEPROM | 50 |
| 4.21.5 | Step 4 – Read Configuration from OTP | 50 |
| 4.21.6 | Step 5 – Search for Configuration in External EEPROM | 50 |
| 4.21.7 | Step 6 – Complete Configuration | 51 |
| 4.22 | Clock Gating and Logic Power-Down Control | 51 |
| 4.23 | Serial Port Functions | 51 |
| 4.23.1 | Addressing Registers within the RC32112A | 52 |
| 4.23.2 | I2C Slave Operation | 52 |
| 4.23.3 | I2C Master | 54 |
| 4.23.4 | SPI Operation | 55 |
| 4.23.5 | JTAG Interface | 56 |
| 5. | Applications Information | 57 |
| 5.1 | Recommendations for Unused Input and Output Pins | 57 |
| 5.1.1 | Inputs | 57 |
| 5.1.2 | Outputs | 57 |
| 5.1.3 | Power Connections | 57 |
| 5.2 | Clock Input Interface | 57 |
| 5.3 | Overdriving the XTAL Interface | 57 |
| 5.4 | Wiring the Differential Input to Accept Single-Ended Levels | 59 |
| 5.5 | Differential Output Termination | 59 |
| 5.6 | External I2C Serial EEPROM Recommendation | 59 |
| 5.7 | Schematic and Layout Information | 60 |
| 5.8 | Power Considerations | 60 |
| 6. | Thermal Information | 60 |

| | | |
|------------|--|-----------|
| 6.1 | VFQFPN EPAD Thermal Release Path | 60 |
| 6.2 | Thermal Characteristics | 61 |
| 7. | Package Outline Drawings | 61 |
| 8. | Marking Diagram | 61 |
| 9. | Ordering Information | 62 |
| 10. | Revision History | 62 |

1. Overview

1.1 Block Diagram

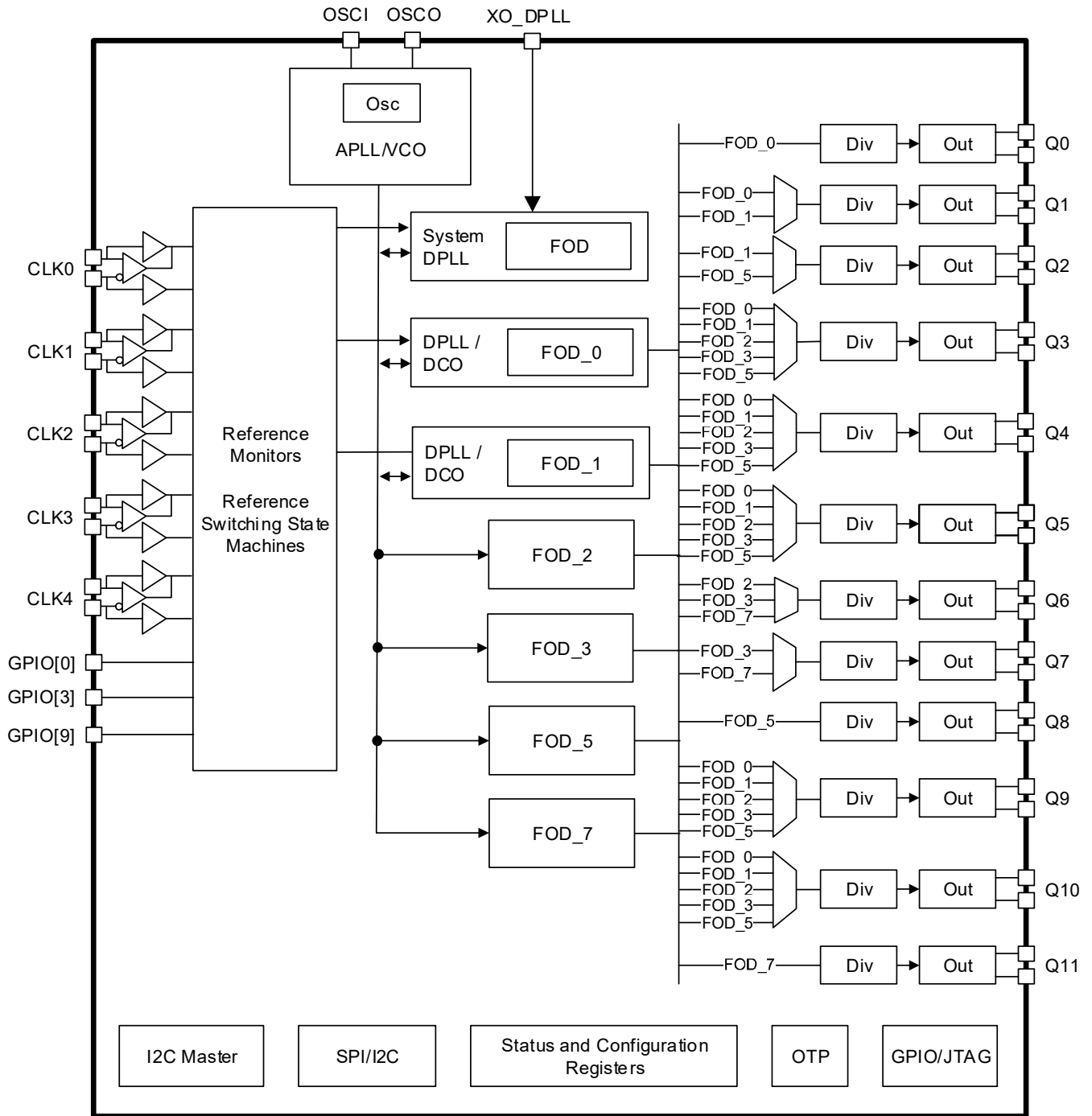

Figure 1. Block Diagram

1.2 Typical Applications

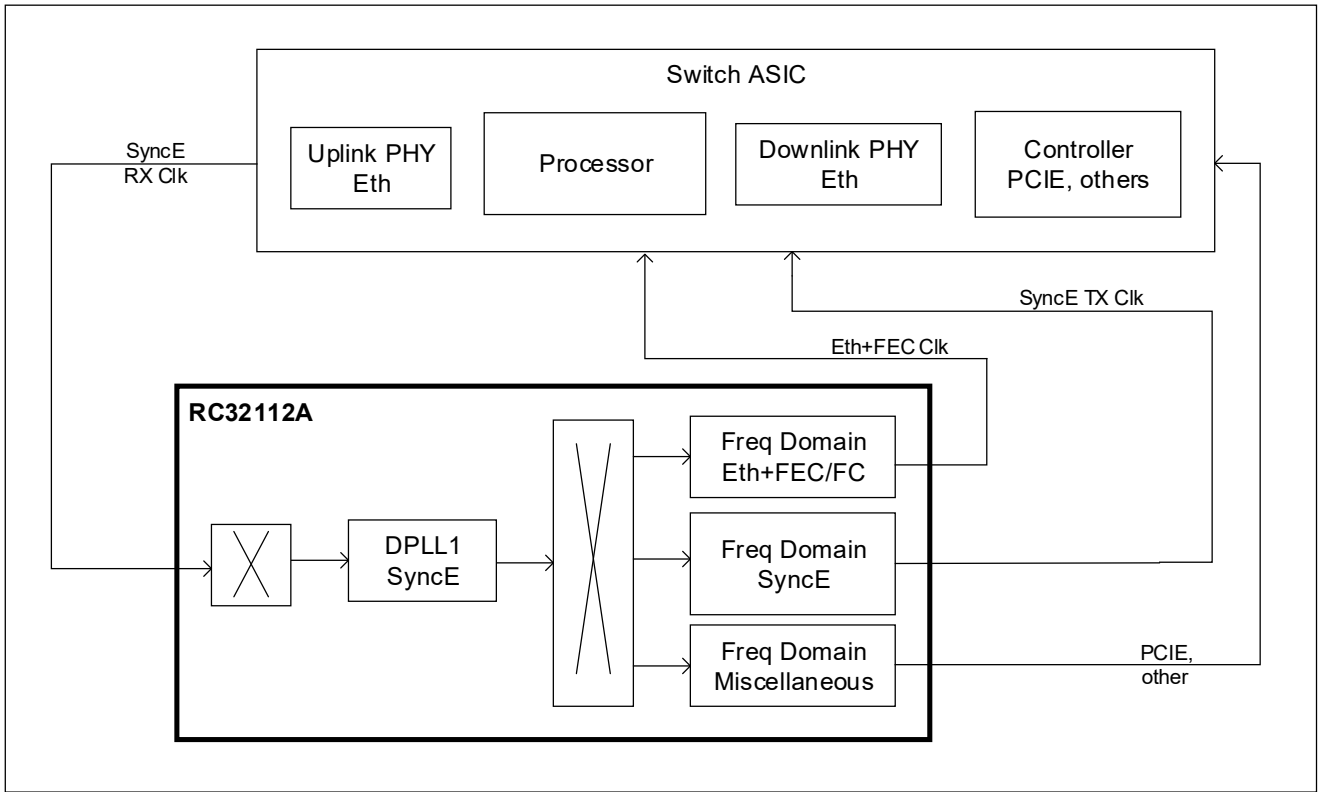

Figure 2. Switch Line Card Application

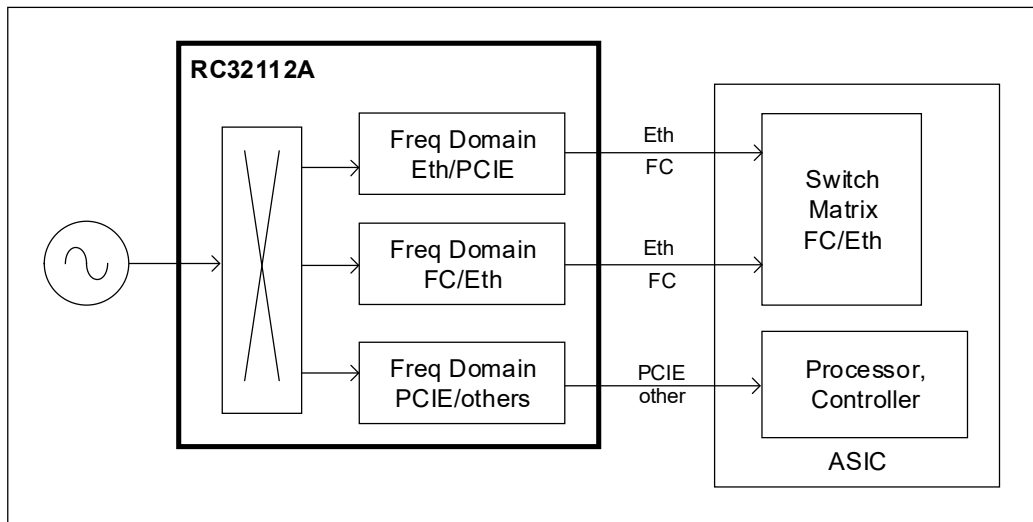
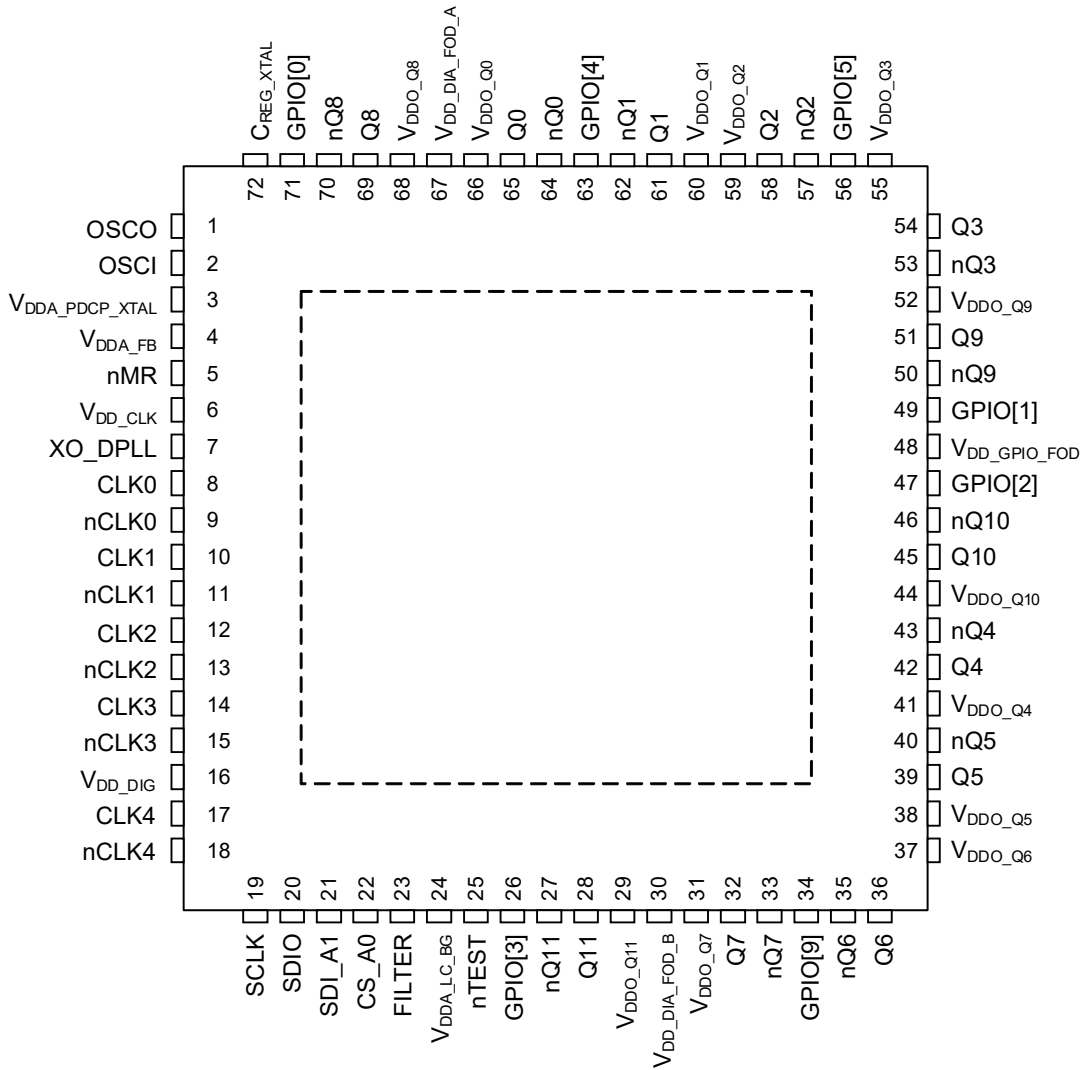

Figure 3. Switch Fabric Card Application

2. Pin Information

2.1 Pin Assignments^[1]



2.2 Pin Descriptions

Table 1. Pin Descriptions ^[1]

| Number | Name | Type | Description |
|--------|----------------|--------|--|
| 1 | OSCO | Output | Crystal Output. This pin should be connected to a crystal. If an oscillator is connected to the OSCI pin, this pin should be left unconnected. |
| 2 | OSCI | Input | Crystal Input. Accepts a reference from a clock oscillator or a fundamental mode parallel-resonant crystal. |
| 3 | VDDA_PDCP_XTAL | Power | Analog power supply voltage for System Analog PLL's phase detector and charge pump, as well as the oscillator circuit associated with OSCI / OSCO pins. 2.5V or 3.3V operation supported. ^[2] |

1. Indexed signals (e.g., GPIO[5]) are not necessarily numbered sequentially (i.e., some indexes may be skipped). This is to maintain software compatibility with other members of the family of devices.

Table 1. Pin Descriptions [1] (Cont.)

| Number | Name | Type | | Description |
|--------|------------------------|--------|-----------|---|
| 4 | V _{DDA_FB} | Power | | Analog power supply voltage for System Analog PLL's feedback divider, 1.8V required. |
| 5 | nMR | Input | Pull-up | Master Reset input (see Power-Up, Configuration and Serial Interfaces). |
| 6 | V _{DD_CLK} | Power | | Power supply for input clock buffers and dividers. Supports 1.8V, 2.5V, or 3.3V as appropriate for the input clock swing. |
| 7 | XO_DPLL | Input | | Single-ended crystal oscillator input for System Digital PLL. |
| 8 | CLK0 | Input | Pull-down | Positive input for differential input Clock 0 or single-ended input for Clock 0. |
| 9 | nCLK0 | Input | Pull-up | Negative input for differential input Clock 0 or single-ended input for Clock 8. |
| 10 | CLK1 | Input | Pull-down | Positive input for differential input Clock 1 or single-ended input for Clock 1. |
| 11 | nCLK1 | Input | Pull-up | Negative input for differential input Clock 1 or single-ended input for Clock 9. |
| 12 | CLK2 | Input | Pull-down | Positive input for differential input Clock 2 or single-ended input for Clock 2. |
| 13 | nCLK2 | Input | Pull-up | Negative input for differential input Clock 2 or single-ended input for Clock 10. |
| 14 | CLK3 | Input | Pull-down | Positive input for differential input Clock 3 or single-ended input for Clock 3. |
| 15 | nCLK3 | Input | Pull-up | Negative input for differential input Clock 3 or single-ended input for Clock 11. |
| 16 | V _{DD_DIG} | Power | | Power supply for digital logic. 1.2V or 1.8V supported. |
| 17 | CLK4 | Input | Pull-down | Positive input for differential input Clock 4 or single-ended input for Clock 4. |
| 18 | nCLK4 | Input | Pull-up | Negative input for differential input Clock 4 or single-ended input for Clock 12. |
| 19 | SCLK | I/O | Pull-up | Main serial port clock input. Used in both SPI and I ² C modes as the clock. This pin can also be used when device boots as I ² C Clock Output for I ² C Master Operation. External pull-up recommended in I ² C mode. |
| 20 | SDIO | I/O | Pull-up | Main serial port bi-directional data pin. Used as a bi-directional data pin in I ² C and 3-wire SPI modes. Used as Serial Data Output pin in 4-wire SPI mode. This pin can also be used when device boots as I ² C Bi-directional Data for I ² C Master Operation. External pull-up recommended in I ² C mode. |
| 21 | SDI_A1 | Input | Pull-up | Main serial port input. Used as Serial Data In in 4-wire SPI mode and optionally as an Address Bit 1 select input in I ² C mode. Unused in 3-wire SPI mode. |
| 22 | CS_A0 | Input | Pull-up | Main serial port input. Used as a Chip Select input in SPI mode and optionally as an Address Bit 0 select input in I ² C mode. |
| 23 | FILTER | Analog | | Reference capacitor for System Analog PLL Loop Filter. Requires a 2.2nF capacitor to ground. |
| 24 | V _{DDA_LC_BG} | Power | | Analog power supply voltage for System Analog PLL's LC Resonator and bandgap regulator, 3.3V or 2.5V supported. ^[2] |
| 25 | nTEST | Input | Pull-up | Test Mode enable pin. Must be high for normal operation |

Table 1. Pin Descriptions [1] (Cont.)

| Number | Name | Type | | Description |
|--------|---------------------------|--------|------------------------|--|
| 26 | GPIO[3] | I/O | Pull-up ^[3] | General Purpose Input / Output 3. |
| 27 | nQ11 | Output | | Q11 clock negative output. |
| 28 | Q11 | Output | | Q11 clock positive output. |
| 29 | V _{DDO_Q11} | Power | | Power supply for Q11/nQ11 output buffers. ^[4] |
| 30 | V _{DD_DIA_FOD_B} | Power | | Power Supply for FOD control logic for FOD_2, FOD_3 and FOD_7. Also powers FOD_2, FOD_3 and FOD_7. 1.8V supply required. |
| 31 | V _{DDO_Q7} | Power | | Power supply for Q7/nQ7 output buffers. ^[4] |
| 32 | Q7 | Output | | Q7 clock positive output. |
| 33 | nQ7 | Output | | Q7 clock negative output. |
| 34 | GPIO[9] | I/O | Pull-up ^[3] | General Purpose Input / Output 9. |
| 35 | nQ6 | Output | | Q6 clock negative output. |
| 36 | Q6 | Output | | Q6 clock positive output. |
| 37 | V _{DDO_Q6} | Power | | Power supply for Q6/nQ6 output buffers. ^[4] |
| 38 | V _{DDO_Q5} | Power | | Power supply for Q5/nQ5 output buffers. ^[4] |
| 39 | Q5 | Output | | Q5 clock positive output. |
| 40 | nQ5 | Output | | Q5 clock negative output. |
| 41 | V _{DDO_Q4} | Power | | Power supply for Q4/nQ4 output buffers. ^[4] |
| 42 | Q4 | Output | | Q4 clock positive output. |
| 43 | nQ4 | Output | | Q4 clock negative output. |
| 44 | V _{DDO_Q10} | Power | | Power supply for Q10/nQ10 output buffers. ^[4] |
| 45 | Q10 | Output | | Q10 clock positive output. |
| 46 | nQ10 | Output | | Q10 clock negative output. |
| 47 | GPIO[2] | I/O | Pull-up ^[3] | General Purpose Input / Output 2. |
| 48 | V _{DD_GPIO_FOD} | Power | | Combined Power Supply input for all the digital pins, including GPIO pins and serial ports pins as well as FOD_5. Only 1.8V supported. |
| 49 | GPIO[1] | I/O | Pull-up ^[3] | General Purpose Input / Output 1. |
| 50 | nQ9 | Output | | Q9 clock negative output. |
| 51 | Q9 | Output | | Q9 clock positive output. |
| 52 | V _{DDO_Q9} | Power | | Power supply for Q9/nQ9 output buffers. ^[4] |
| 53 | nQ3 | Output | | Q3 clock negative output. |
| 54 | Q3 | Output | | Q3 clock positive output. |
| 55 | V _{DDO_Q3} | Power | | Power supply for Q3/nQ3 output buffers. ^[4] |
| 56 | GPIO[5] | I/O | Pull-up ^[3] | General Purpose Input / Output 5. |
| 57 | nQ2 | Output | | Q2 clock negative output. |
| 58 | Q2 | Output | | Q2 clock positive output. |
| 59 | V _{DDO_Q2} | Power | | Power supply for Q2/nQ2 output buffers. ^[4] |
| 60 | V _{DDO_Q1} | Power | | Power supply for Q1/nQ1 output buffers. ^[4] |
| 61 | Q1 | Output | | Q1 clock positive output. |
| 62 | nQ1 | Output | | Q1 clock negative output. |
| 63 | GPIO[4] | I/O | Pull-up ^[3] | General Purpose Input / Output 4. |

Table 1. Pin Descriptions [1] (Cont.)

| Number | Name | Type | | Description |
|--------|---------------------------|--------|------------|---|
| 64 | nQ0 | Output | | Q0 clock negative output. |
| 65 | Q0 | Output | | Q0 clock positive output. |
| 66 | V _{DDO_Q0} | Power | | Power supply for Q0/nQ0 output buffers.[4] |
| 67 | V _{DD_DIA_FOD_A} | Power | | Power supply for FOD control logic for FOD_0, FOD_1 and FOD_5. Also powers FOD_0, FOD_1. 1.8V supply required. |
| 68 | V _{DDO_Q8} | Power | | Power supply for Q8/nQ8 output buffers. [4] |
| 69 | Q8 | Output | | Q8 clock positive output. |
| 70 | nQ8 | Output | | Q8 clock negative output. |
| 71 | GPIO[0] | I/O | Pull-up[3] | General Purpose Input / Output 0. |
| 72 | C _{REG_XTAL} | Power | | Filter capacitor for voltage regulator for oscillator circuit associated with OSCI / OSCO pins. Requires a 10µF filter capacitor to ground. |
| ePAD | V _{SS} | Power | | Device ePAD must be connected to Ground. |

1. Pull-up and pull-down refer to internal input resistors (for typical values, see [Table 2](#)).
2. V_{DDA_PDCP_XTAL} and V_{DDA_LC_BG} can be driven with either 2.5V or 3.3V, however, both must use the same voltage level. Register programming is required to configure the device for either 2.5V or 3.3V operation. For more information, see the *8A3xxx Family Programming Guide*.
3. GPIO pins can be configured via EEPROM and/or OTP with a pull-up or a pull-down. Pull-up is the default configuration.
4. For voltages supported, see [Clock Outputs](#).

2.3 Pin Characteristics

Table 2. Pin Characteristics

| Symbol | Parameter | | Test Condition | Minimum | Typical | Maximum | Unit | |
|---------------------------------|---|----------------|---|---------|---------|---------|------|--|
| C _{IN} | Input Capacitance | OSCI, OSCO | | | 9 | | pF | |
| | | All Other pins | | | 2 | | | |
| R _{PULLUP} | Input Pull-up Resistor | nCLK[4:0] | | | 50 | | kΩ | |
| R _{PULLDOWN} | Input Pull-down Resistor | CLK[4:0] | | | 50 | | kΩ | |
| C _{PD} | Power Dissipation Capacitance (per output pair) | LVCMOS | V _{DDO_Qx} ^[1] = 3.465V | | 9 | | pF | |
| | | | V _{DDO_Qx} = 2.625V | | 8.8 | | | |
| | | | V _{DDO_Qx} = 1.89V | | 8.8 | | | |
| | | | V _{DDO_Qx} = 1.575V | | 9.2 | | | |
| | | | V _{DDO_Qx} = 1.26V | | 8.7 | | | |
| | | Differential | V _{DDO_Qx} = 3.465V | | 1.4 | | | |
| | | | V _{DDO_Qx} = 2.625V | | 3.5 | | | |
| R _{OUT} ^[2] | Output Impedance | GPIO[9,5:0] | V _{DD_GPIO_FOD} = 1.8V | | 32 | | Ω | |
| | | SDIO, SCLK | V _{DD_GPIO_FOD} = 1.8V | | 38 | | | |

1. V_{DDO_Qx} denotes: V_{DDO_Q0}, V_{DDO_Q1}, V_{DDO_Q2}, V_{DDO_Q3}, V_{DDO_Q4}, V_{DDO_Q5}, V_{DDO_Q6}, V_{DDO_Q7}, V_{DDO_Q8}, V_{DDO_Q9}, V_{DDO_Q10}, or V_{DDO_Q11}
2. Output impedance values for the Qx / nQx outputs are provided in [Table 26](#).

3. Specifications

3.1 Abbreviations Used

Many signals will be concatenated for simplicity in the specification tables that follow. [Table 3](#) shows a list of abbreviations used and will be referred to in footnotes for the various other tables.

Table 3. Abbreviated Signal Names and the Detailed Signal Names Referenced by Them

| Abbreviation | Signals Referenced by this Abbreviation |
|----------------|---|
| V_{DD_CLKx} | V_{DD_CLK} |
| Input CLK | CLK[4:0], nCLK[4:0] |
| Output Q | Q[11:0], nQ[11:0] |
| Status Outputs | GPIO[9,5:0], SDIO |
| GPIO | GPIO[9,5:0] |
| V_{DDx} | $V_{DDA_PDCP_XTAL}$, V_{DD_CLK} , V_{DDA_FB} , $V_{DDA_BG_LC}$, V_{DD_DIG} , $V_{DD_GPIO_FOD}$, $V_{DDA_DIA_FOD_A}$, $V_{DDA_DIA_FOD_B}$, V_{DDO_Q0} , V_{DDO_Q1} , V_{DDO_Q2} , V_{DDO_Q3} , V_{DDO_Q4} , V_{DDO_Q5} , V_{DDO_Q6} , V_{DDO_Q7} , V_{DDO_Q8} , V_{DDO_Q9} , V_{DDO_Q10} , V_{DDO_Q11} , |
| V_{DDO_Qx} | V_{DDO_Q0} , V_{DDO_Q1} , V_{DDO_Q2} , V_{DDO_Q3} , V_{DDO_Q4} , V_{DDO_Q5} , V_{DDO_Q6} , V_{DDO_Q7} , V_{DDO_Q8} , V_{DDO_Q9} , V_{DDO_Q10} , V_{DDO_Q11} |

3.2 Absolute Maximum Ratings

The absolute maximum ratings are stress ratings only. Stresses greater than those listed below can cause permanent damage to the device. Functional operation of the RC32112A at absolute maximum ratings is not implied. Exposure to absolute maximum rating conditions may affect device reliability.

Table 4. Absolute Maximum Ratings

| Symbol | Parameter | Test Condition | Minimum | Maximum | Unit |
|-----------------|------------------------------|--|---------|---------|------|
| $V_{DDx}^{[1]}$ | Any voltage supply | | -0.5 | 3.63 | V |
| V_{IN} | Voltage on any input | OSC ^[2] , OSCO, FILTER, C_{REG_XTAL} | 0 | 2.75 | V |
| | | All other inputs | -0.5 | 3.63 | V |
| I_{IN} | Differential Input Current | Input CLK ^[1] | | ±50 | mA |
| I_O | Output Current - Continuous | Output Q ^[1] | | 30 | mA |
| | | Status Outputs ^[1] | | 25 | mA |
| | Output Current - Surge | Output Q | | 60 | mA |
| | | Status Outputs | | 50 | mA |
| T_{JMAX} | Maximum Junction Temperature | | | 150 | °C |
| T_S | Storage temperature | | -65 | 150 | °C |
| - | ESD - Human Body Model | | | 2000 | V |
| - | ESD - Charged Device Model | | | 1500 | V |

1. For information on the signals referenced by this abbreviation, see [Table 3](#).

2. This limit only applies to the OSC_I input when being over-driven by an external signal. No limit is implied when this is connected directly to a crystal.

3.3 Recommended Operating Conditions

Table 5. Recommended Operating Conditions [1]

| Symbol | Parameter | Minimum | Typical | Maximum | Unit |
|--------|---------------------------------|---------|---------|---------|------|
| T_A | Ambient air temperature | -40 | | 85 | °C |
| T_C | Case temperature ^[2] | -40 | | 105 | °C |

1. It is the user's responsibility to ensure that device junction temperature remains below the maximum allowed.
2. Measured at solder connection to Printed Circuit Board on any signal, voltage, or ePAD.

3.4 Supply Voltage Characteristics

Table 6. Power Supply DC Characteristics [1][2]

| Symbol | Parameter | Test Condition | Minimum | Typical | Maximum | Unit |
|-------------------------------|--|-------------------------------------|---------|---------|---------|------|
| V_{DD_CLK} | Supply Voltage for Input Clock Buffers and Dividers | | 1.71 | [3] | 3.465 | V |
| I_{DD_CLKx} ^[4] | Supply Current for V_{DD_CLKx} | $V_{DD_CLKx} = 3.465V$, PMOS mode | | 3 | | mA |
| | | $V_{DD_CLKx} = 3.465V$, NMOS mode | | 6 | | |
| | | $V_{DD_CLKx} = 3.465V$, CMOS mode | | 1.5 | | |
| | | $V_{DD_CLKx} = 2.625V$, PMOS mode | | 2.6 | | |
| | | $V_{DD_CLKx} = 2.625V$, NMOS mode | | 6 | | |
| | | $V_{DD_CLKx} = 2.625V$, CMOS mode | | 1 | | |
| | | $V_{DD_CLKx} = 1.89V$, PMOS mode | | 2.5 | | |
| | | $V_{DD_CLKx} = 1.89V$, NMOS mode | | 5 | | |
| | $V_{DD_CLKx} = 1.89V$, CMOS mode | | 1 | | | |
| $V_{DDA_PDCP_XTAL}$ | Analog Supply Voltage for oscillator and for APLL Phase detector and Charge Pump | | 2.375 | [5] | 3.465 | V |
| $I_{DDA_PDCP_XTAL}$ | Supply Current for $V_{DDA_PDCP_XTAL}$ | $V_{DDA_PDCP_XTAL} = 3.3V$ | | 48 | | mA |
| | | $V_{DDA_PDCP_XTAL} = 2.5V$ | | 33 | | mA |
| V_{DDA_FB} | Analog Supply Voltage for APLL Feedback Divider | | 1.71 | 1.8 | 1.89 | V |
| I_{DDA_FB} | Supply Current for V_{DDA_FB} | $V_{DDA_FB} = 1.89V$ | | 22 | | mA |
| $V_{DDA_BG_LC}$ | Analog Supply Voltage for APLL Bandgap reference and LC Resonator | | 2.375 | [5] | 3.465 | V |
| $I_{DDA_BG_LC}$ | Supply Current for $V_{DDA_BG_LC}$ | $V_{DDA_BG_LC} = 3.465V$ | | 125 | | mA |
| | | $V_{DDA_BG_LC} = 2.625V$ | | 88 | | mA |
| V_{DD_DIG} | Digital Supply Voltage | | 1.14 | [6] | 1.89 | V |

Table 6. Power Supply DC Characteristics [1][2] (Cont.)

| Symbol | Parameter | Test Condition | Minimum | Typical | Maximum | Unit |
|--|--|--|---------|---------|---------|--------|
| I _{DD_DIG} | Supply Current for V _{DD_DIG} | V _{DD_DIG} = 1.89V | | 190 | | mA |
| | | V _{DD_DIG} = 1.26V | | 180 | | mA |
| V _{DD_GPIO_FOD} | Power Supply Voltage for FOD blocks FOD_5, GPIO and other status / control signals | | 1.71 | 1.8 | 1.89 | V |
| I _{DD_GPIO_FOD} ^[7] | Supply Current for V _{DD_GPIO_FOD} ^[8] | V _{DD_GPIO_FOD} = 1.89V Base current (FOD Off) I _{DD(FODBASE)} | | 30 | | mA |
| | | Adder for FOD at 500MHz I _{DD(FODPERFOD)} | | 27 | | mA |
| | | Adder per 1MHz over 500MHz on FOD I _{DD(FODPERMHZ)} | | 0.012 | | mA/MHz |
| V _{DD_DIA_FOD_A} | Supply Voltage for FOD control logic for FOD_0, FOD_1 and FOD_5 and for FOD_0, FOD_1 | | 1.71 | 1.8 | 1.89 | V |
| I _{DD_DIA_FOD_A} | Supply Current for V _{DD_DIA_FOD_A} ^[9] | V _{DDA_DIA_FOD_A} = 1.89V | | 45 | | mA |
| | | Adder per FOD at 500MHz | | 30 | | mA |
| | | Adder per FOD per 1MHz over 500MHz | | 0.012 | | mA/MHz |
| V _{DD_DIA_FOD_B} | Supply Voltage for FOD control logic for FOD_2, FOD_3 and FOD_7 and for FOD_2, FOD_3 and FOD_7 | | 1.71 | 1.8 | 1.89 | V |
| I _{DDA_DIA_FOD_B} ^[10] | Supply Current for V _{DDA_DIA_FOD_B} ^[9] | V _{DDA_DIA_FOD_B} = 1.89V | | 69 | | mA |
| | | Adder per FOD at 500MHz | | 30 | | mA |
| | | Adder per FOD per 1MHz over 500MHz | | 0.012 | | mA/MHz |
| V _{DDO_Qx} ^[11] | Output Clock Q Supply Voltage ^[12] | | 1.14 | | 3.465 | V |

1. V_{SS} = 0V, T_A = -40°C to 85°C.
2. Current consumption figures represent a worst-case consumption with all functions associated with the particular voltage supply being all enabled and running at full capacity. This information is provided to allow for design of appropriate power supply circuits that will support all possible register-based configurations for the device.
3. Supports 1.8V ±5%, 2.5V ±5%, or 3.3V ±5% operation, not a continuous range.
4. I_{DD_CLKx} denotes the current consumed by the appropriate V_{DD_CLKx} supply voltage.
5. Supports 2.5V ±5% or 3.3V ±5% operation, not a continuous range.
6. Supports 1.2V ±5% or 1.8V ±5% operation, not a continuous range.
7. I_{DD_DCO_Qx} denotes the current consumed by the appropriate V_{DD_DCO_Qx} supply voltage. This is the current consumption for each supply, not the total for all V_{DD_DCO_Qx}.

8. The $I_{DD_GPIO_FOD}$ current consumed is dependent on the number of FODs attached to the voltage rail that are supported and the frequency of operation of those FODs. For information on which FODs are supported by which power supply, see [Pin Descriptions](#) and [Pin Characteristics](#). A calculation needs to be performed using the formula below, where f_{FOD} is the operating frequency of each FOD, NumFOD is the number of FODs on that supply that are enabled. Note that only the base current is needed if all FODs are disabled.

$$I_{DD(FOD)} = I_{DD(FODBASE)} + NumFOD \times I_{DD(FODPERFOD)} + \sum_{operatingDCO} (f_{FOD} - 500) \times I_{DD(FODPERMHZ)}$$

9. The I_{DDA_DIA} current consumed is dependent on the number of FODs attached to the voltage rail that are supported and the frequency of operation of those FODs. For information on which FODs are supported by which power supply, see [Pin Descriptions](#) and [Pin Characteristics](#). A calculation needs to be performed using the formula below, where f_{FOD} is the operating frequency of each FOD, NumFOD is the number of FODs on that supply that are enabled. Note that only the base current is needed if all FODs are disabled.

$$I_{DD(DIA)} = I_{DD(DIABASE)} + NumFOD \times I_{DD(DIAPERFOD)} + \sum_{operatingDCO} (f_{FOD} - 500) \times I_{DD(DIAPERMHZ)}$$

10. $V_{DDA_DIA_FOD_B}$ consumes higher current than $V_{DDA_DIA_FOD_A}$ because it has some additional circuitry, besides the FODs on it.

11. For information on the signals referenced by this abbreviation, see [Table 3](#).

12. Currents for the outputs are shown in [Table 7](#) or [Table 8](#) as appropriate for the mode the individual output is operating in.

Table 7. Output Supply Current (Output Configured as Differential) [1][2][3]

| Symbol | Parameter | Test Condition | SWING ^[4] = 00 | SWING = 01 | SWING = 10 | SWING = 11 | Unit |
|------------------------------|--|---------------------------------------|---------------------------|------------|------------|------------|------|
| I_{DDO_Qx} ^[5] | Qx / nQx Supply Current ^[6] | V_{DDO_Qx} ^[7] = 3.465V | 15 | 17 | 19 | 20 | mA |
| | | V_{DDO_Qx} = 2.625V | 14 | 16 | 18 | 19 | mA |
| | | V_{DDO_Qx} = 1.89V | 14 | 15 | 16 | 16 | mA |

- Output current consumption is not affected by any of the core device power supply voltage levels.
- Internal dynamic switching current at maximum f_{OUT} is included.
- V_{DDO_Qx} = 3.3V ±5% or 2.5V ±5%, or 1.8V ±5%, V_{SS} = 0V, T_A = -40°C to 85°C.
- Refers to the output voltage (swing) setting programmed into device registers for each output.
- I_{DDO_Qx} denotes the current consumed by each V_{DDO_Qx} supply.
- Measured with outputs unloaded.
- For information on the signals referenced by this abbreviation, see [Table 3](#).

Table 8. Output Supply Current (Output Configured as LVCMOS) [1][2][3]

| Symbol | Parameter | Test Condition | TERM ^[4] = 00 | | TERM = 01 | | TERM = 10 | | TERM = 11 | | Unit |
|------------------------------|--|---------------------------------------|--------------------------|------|-----------|------|-----------|------|-----------|------|------|
| | | | Typ. | Max. | Typ. | Max. | Typ. | Max. | Typ. | Max. | |
| I_{DDO_Qx} ^[5] | Qx, nQx Supply Current ^[6] | V_{DDO_Qx} ^[7] = 3.465V | 24 | 32 | 25 | 35 | 25 | 37 | 25 | 39 | mA |
| | | V_{DDO_Qx} = 2.625V | 18 | 25 | 19 | 27 | 19 | 29 | 20 | 30 | |
| | | V_{DDO_Qx} = 1.89V | 12 | 20 | 14 | 21 | 15 | 22 | 15 | 23 | |
| | | V_{DDO_Qx} = 1.575V | 9 | 17 | 11 | 18 | 11 | 19 | 12 | 20 | |
| | | V_{DDO_Qx} = 1.26V | 6 | 13 | 6 | 13 | 6 | 14 | 6 | 14 | |
| | Qx, nQx Supply Current ^[8] Qx enabled and nQx Tri-stated | V_{DDO_Qx} = 3.465V | 14 | 23 | 14 | 24 | 14 | 25 | 14 | 26 | mA |
| | | V_{DDO_Qx} = 2.625V | 11 | 19 | 11 | 20 | 11 | 20 | 11 | 21 | |
| | | V_{DDO_Qx} = 1.89V | 9 | 16 | 10 | 17 | 10 | 17 | 10 | 18 | |
| | | V_{DDO_Qx} = 1.575V | 8 | 15 | 8 | 16 | 9 | 16 | 9 | 16 | |
| | | V_{DDO_Qx} = 1.26V | 5 | 12 | 5 | 12 | 5 | 12 | 5 | 12 | |

1. Output current consumption is not affected by any of the core device power supply voltage levels.
2. Internal dynamic switching current at maximum f_{OUT} is included.
3. $V_{SS} = 0V$, $T_A = -40^{\circ}C$ to $85^{\circ}C$.
4. Refers to the LVCMOS output drive strength (termination) setting programmed into device registers for each output.
5. I_{DDO_Qx} denotes the current consumed by each V_{DDO_Qx} supply.
6. Measured with outputs unloaded.
7. For information on the signals referenced by this abbreviation, see [Table 3](#).
8. Measured with outputs unloaded.

3.5 DC Electrical Characteristics

Table 9. LVCMOS/LVTTL DC Characteristics [1][2][3][4][5]

| Symbol | Parameter | | Test Condition | Minimum | Typical | Maximum | Unit |
|----------|--------------------|---|--|----------------------------|---------|----------------------------|---------|
| V_{IH} | Input High Voltage | nMR, nTEST, GPIO[9,8,5:0], SCLK, SDIO, SDI_A1, CS_A0, SDA_M | $V_{DD_GPIO} = 1.8V \pm 5\%$ | $0.65 \times V_{DD_GPIO}$ | | $V_{DD_GPIO} + 0.3$ | V |
| V_{IH} | Input High Voltage | XO_DPLL | $V_{DD_DIG} = 1.8V \pm 5\%$ | 1.17 | | 3.465 | V |
| | | | $V_{DD_DIG} = 1.2V \pm 5\%$ | 1.17 | | 3.465 | V |
| V_{IH} | Input High Voltage | CLK[4:0], nCLK[4:0] ^[5] | $V_{DD_CLK} = 3.3V \pm 5\%$ | 2 | | $V_{DD_CLK} + 0.3$ | V |
| | | | $V_{DD_CLK} = 2.5V \pm 5\%$ | 1.7 | | $V_{DD_CLK} + 0.3$ | V |
| | | | $V_{DD_CLK} = 1.8V \pm 5\%$ | $0.65 \times V_{DD_CLK}$ | | $V_{DD_CLK} + 0.3$ | V |
| V_{IL} | Input Low Voltage | nMR, nTEST, GPIO[9,5:0], SCLK, SDIO, SDI_A1, CS_A0, SDA_M | $V_{DD_GPIO} = 1.8V \pm 5\%$ | -0.3 | | $0.35 \times V_{DD_GPIO}$ | V |
| V_{IL} | Input Low Voltage | XO_DPLL | $V_{DD_DIG} = 1.8V \pm 5\%$ | -0.3 | | $0.35 \times V_{DD_DIG}$ | V |
| | | | $V_{DD_DIG} = 1.2V \pm 5\%$ | -0.3 | | $0.25 \times V_{DD_DIG}$ | V |
| V_{IL} | Input Low Voltage | CLK[4:0], nCLK[4:0] ^[5] | $V_{DD_CLK} = 3.3V \pm 5\%$ | -0.3 | | 0.8 | V |
| | | | $V_{DD_CLK} = 2.5V \pm 5\%$ | -0.3 | | 0.7 | |
| | | | $V_{DD_CLK} = 1.8V \pm 5\%$ | -0.3 | | $0.35 \times V_{DD_CLK}$ | |
| I_{IH} | Input High Current | nMR, nTEST, GPIO[9,5:0], SDA_M, SCLK, SDIO, SDI_A1, CS_A0 | $V_{IN} = V_{DD_GPIO} = V_{DD_GPIO} (max)$ | | | 5 | μA |
| I_{IH} | Input High Current | XO_DPLL | $V_{IN} = 3.465V$ $V_{DD_DIG} = V_{DD_DIG} (max)$ | | | 150 | μA |
| I_{IH} | Input High Current | CLK[4:0] | $V_{IN} = V_{DD_CLK} = V_{DD_CLK} (max)$ | | | 150 | μA |
| | | nCLK[4:0] | | | | 5 | |
| I_{IL} | Input Low Current | nMR, nTEST, GPIO[9,5:0], SDA_M, SCLK, SDIO, SDI_A1, CS_A0 | $V_{IN} = 0V$, $V_{DD_GPIO} = V_{DD_GPIO} (max)$ | -150 | | | μA |

Table 9. LVCMOS/LVTTL DC Characteristics [1][2][3][4][5] (Cont.)

| Symbol | Parameter | | Test Condition | Minimum | Typical | Maximum | Unit |
|----------|---------------------|---------------------------------------|--|-----------------------|---------|---------|---------|
| I_{IL} | Input Low Current | XO_DPLL | $V_{IN} = 0V$ $V_{DD_DIG} = V_{DD_DIG} (max)$ | -5 | | | μA |
| I_{IL} | Input Low Current | CLK[4:0] | $V_{IN} = 0V,$ $V_{DD_CLK} = V_{DD_CLK} (max)$ | -5 | | | μA |
| | | nCLK[4:0] | | -150 | | | |
| V_{OH} | Output High Voltage | GPIO[9,5:0], SDA_M, SCL_M, SCLK, SDIO | $V_{DD_GPIO} = 1.8V \pm 5\%,$ $I_{OH} = -100\mu A$ | $V_{DD_GPIO} - 0.2$ | | | V |
| | | | $V_{DD_GPIO} = 1.8V \pm 5\%,$ $I_{OH} = -2mA$ | $V_{DD_GPIO} - 0.45$ | | | |
| V_{OL} | Output Low Voltage | GPIO[9,5:0], SDA_M, SCL_M, SCLK, SDIO | $V_{DD_GPIO} = 1.8V \pm 5\%,$ $I_{OL} = 100\mu A$ | | | 0.2 | V |
| | | | $V_{DD_GPIO} = 1.8V \pm 5\%,$ $I_{OL} = 2mA$ | | | 0.45 | |

- V_{IL} should not be less than -0.3V.
- 3.3V characteristics in accordance with JESD8C-01, 2.5V characteristics in accordance with JESD8-5A.01, 1.8V characteristics in accordance with JESD8-7A, 1.5V characteristics in accordance with JESD8-11A.01, 1.2V characteristics in accordance with JESD8-12A.01
- $V_{SS} = 0V, T_A = -40^\circ C$ to $85^\circ C$.
- When Output Q are configured as LVCMOS, their output characteristics are specified in [Table 15](#).
- Input pair used as two single-ended clocks rather than as a differential clock.

Table 10. Low-swing Mode Single-ended Input DC Characteristics [1][2][3][4][5]

| Symbol | Parameter | Test Condition | Minimum | Typical | Maximum | Unit |
|----------|----------------------|----------------|---------|---------|---------|------|
| V_{PP} | Peak-to-Peak Voltage | | 0.15 | | 1.3 | V |

- V_{IL} should not be less than -0.3V.
- V_{IH} should not be higher than V_{DD_CLK} .
- $V_{SS} = 0V, T_A = -40^\circ C$ to $85^\circ C$.
- Input pair used as two single-ended clocks rather than a differential clock.
- Input must be AC coupled.

Table 11. Differential Input DC Characteristics [1]

| Symbol | Parameter | | Test Condition | Minimum | Typical | Maximum | Unit |
|------------------|---|------------------------|--|---------|---------|---------------------------|------|
| I _{IH} | Input High Current | CLK[4:0] | V _{IN} = V _{DD_CLK} = V _{DD_CLK} (max) | | | 150 | μA |
| | | nCLK[4:0] | | | | 5 | |
| I _{IL} | Input Low Current | CLK[4:0] | V _{IN} = 0V, V _{DD_CLK} = V _{DD_CLK} (max) | -5 | | | μA |
| | | nCLK[4:0] | | -150 | | | |
| V _{PP} | Peak-to-Peak Voltage ^{[2][3]} | | Any input protocol | 0.15 | | 1.3 | V |
| V _{CMR} | Common Mode Input Voltage ^{[2][4]} | CLK[4:0], nCLK[4:0] | Input protocol = HCSL, HSTL, SSTL | 0.1 | | V _{DD_CLK} - 1.2 | V |
| | | | Input protocol = LVDS, LVPECL, CML | 0.7 | | V _{DD_CLK} | |

1. V_{SS} = 0V, T_A = -40°C to 85°C.
2. V_{IL} should not be less than -0.3V.
3. V_{PP} is the single-ended amplitude of the output signal. The differential specs is 2 * V_{PP}.
4. Common mode voltage is defined as the cross-point.

Table 12. Differential Output DC Characteristics (V_{DDO_Qx} = 3.3V +5%, V_{SS} = 0V, T_A = -40°C to 85°C) [1][2][3][4]

| Symbol | Parameter | | Test Condition | Minimum | Typical | Maximum | Unit |
|---------------------------------|----------------------------|-------------------------|-----------------------------|---------|---------|---------|------|
| V _{OVS} ^[5] | Output Voltage Swing | Output Q ^[1] | SWING = 00 ^[6] | 336 | 402 | 462 | mV |
| | | | SWING = 01 | 478 | 605 | 698 | |
| | | | SWING = 10 | 658 | 791 | 910 | |
| | | | SWING = 11 | 739 | 870 | 997 | |
| V _{CMR} ^[7] | Output Common Mode Voltage | Output Q ^[1] | CENTER = 000 ^[8] | 0.86 | 0.95 | 1.07 | V |
| | | | CENTER = 001 | 0.98 | 1.14 | 1.28 | |
| | | | CENTER = 010 | 1.13 | 1.33 | 1.51 | |
| | | | CENTER = 011 | 1.30 | 1.53 | 1.73 | |
| | | | CENTER = 100 | 1.46 | 1.73 | 1.95 | |
| | | | CENTER = 101 | 1.63 | 1.93 | 2.17 | |
| | | | CENTER = 110 | 1.80 | 2.12 | 2.39 | |
| | | | CENTER = 111 | 1.96 | 2.30 | 2.59 | |

1. For information on the signals referenced by this abbreviation, see [Table 3](#).
2. Terminated with 100Ω across Qx and nQx.
3. If LVDS operation is desired, select SWING = 00 and CENTER = 001 or 010.
4. If LVPECL operation is desired, select SWING = 10 and CENTER = 101 or 110 for 3.3V LVPECL, and SWING = 10 and CENTER = 001 or 010 for 2.5V LVPECL operation.
5. V_{OVS} is the single-ended amplitude of the output signal. The differential specs is 2 * V_{OVS}.
6. Refers to the differential voltage swing setting programmed into device registers for each output.
7. Not all V_{CMR} selections can be supported with particular V_{DDO_Qx} and V_{OVS} settings.
8. Refers to the differential voltage crossing point (center voltage) setting programmed into device registers for each output.

Table 13. Differential Output DC Characteristics ($V_{DDO_Qx} = 2.5V +5\%$, $V_{SS} = 0V$, $T_A = -40^{\circ}C$ to $85^{\circ}C$) [1][2][3][4]

| Symbol | Parameter | | Test Condition | Minimum | Typical | Maximum | Unit |
|-----------------|----------------------------|-------------|-----------------------------|---------------|---------|---------|------|
| $V_{OVS}^{[5]}$ | Output Voltage Swing | Output Q[1] | SWING = 00 ^[6] | 295 | 393 | 448 | mV |
| | | | SWING = 01 | 457 | 591 | 677 | |
| | | | SWING = 10 | 587 | 761 | 881 | |
| | | | SWING = 11 | 733 | 835 | 943 | |
| $V_{CMR}^{[7]}$ | Output Common Mode Voltage | Output Q[1] | CENTER = 000 ^[8] | 0.85 | 0.93 | 1.03 | V |
| | | | CENTER = 001 | 0.94 | 1.10 | 1.23 | |
| | | | CENTER = 010 | 1.09 | 1.28 | 1.44 | |
| | | | CENTER = 011 | 1.24 | 1.46 | 1.65 | |
| | | | CENTER = 100 | 1.39 | 1.65 | 1.86 | |
| | | | CENTER = 101 | Not Supported | | | |
| | | | CENTER = 110 | | | | |
| | | | CENTER = 111 | | | | |

1. For information on the signals referenced by this abbreviation, see [Table 3](#).
2. Terminated with 100Ω across Qx and nQx.
3. If LVDS operation is desired, select SWING = 00 and CENTER = 001 or 010.
4. If LVPECL operation is desired, select SWING = 10 and CENTER = 001 or 010 for 2.5V LVPECL operation. For $V_{DDO} = 2.5V, 3.3V$ LVPECL levels cannot be generated.
5. V_{OVS} is the single-ended amplitude of the output signal. The differential specs is $2 * V_{OVS}$.
6. Refers to the differential voltage swing setting programed into device registers for each output.
7. Not all V_{CMR} selections can be supported with particular V_{DDO_Qx} and V_{OVS} settings.
8. Refers to the differential voltage crossing point (center voltage) setting programed into device registers for each output.

Table 14. Differential Output DC Characteristics ($V_{DDO_Qx} = 1.8V +5\%$, $V_{SS} = 0V$, $T_A = -40^{\circ}C$ to $85^{\circ}C$) [1][2][3]

| Symbol | Parameter | | Test Condition | Minimum | Typical | Maximum | Unit |
|-----------------|----------------------------|-------------|-----------------------------|---------------|---------|---------|------|
| $V_{OVS}^{[4]}$ | Output Voltage Swing | Output Q[1] | SWING = 00 ^[5] | 299 | 411 | 485 | mV |
| | | | SWING = 01 | 470 | 586 | 700 | |
| | | | SWING = 10 | 582 | 713 | 852 | |
| | | | SWING = 11 | 612 | 750 | 899 | |
| $V_{CMR}^{[6]}$ | Output Common Mode Voltage | Output Q[1] | CENTER = 000 ^[7] | 0.84 | 0.91 | 0.99 | V |
| | | | CENTER = 001 | 0.91 | 1.05 | 1.18 | |
| | | | CENTER = 010 | 1.05 | 1.21 | 1.36 | |
| | | | CENTER = 011 | Not Supported | | | |
| | | | CENTER = 100 | | | | |
| | | | CENTER = 101 | | | | |
| | | | CENTER = 110 | | | | |
| | | | CENTER = 111 | | | | |

1. For information on the signals referenced by this abbreviation, see [Table 3](#).
2. Terminated with 100Ω across Qx and nQx.
3. If LVDS operation is desired, select SWING = 00 and CENTER = 010.
4. V_{OVS} is the single-ended amplitude of the output signal. The differential specs is $2 * V_{OVS}$.

- 5. Refers to the differential voltage swing setting programmed into device registers for each output.
- 6. Not all V_{CMR} selections can be supported with particular V_{DDO_Qx} and V_{OVS} settings.
- 7. Refers to the differential voltage crossing point (center voltage) setting programmed into device registers for each output.

Table 15. LVC MOS Clock Output DC Characteristics [1][2]

| Symbol | Parameter | Test Condition | TERM ^[3] = 00 | | | TERM = 01 | | | TERM = 10 | | | TERM = 11 | | | Unit |
|-----------|---------------------|------------------------------|---------------------------|------|---------------------------|---------------------------|------|---------------------------|---------------------------|------|---------------------------|---------------------------|------|---------------------------|------|
| | | | Min. | Typ. | Max. | Min. | Typ. | Max. | Min. | Typ. | Max. | Min. | Typ. | Max. | |
| V_{OH} | Output High Voltage | $V_{DDO_Qx} = 3.3V \pm 5\%$ | $0.74 \times V_{DDO_Qx}$ | | | $0.75 \times V_{DDO_Qx}$ | | | $0.75 \times V_{DDO_Qx}$ | | | $0.75 \times V_{DDO_Qx}$ | | | V |
| | | $V_{DDO_Qx} = 2.5V \pm 5\%$ | $0.70 \times V_{DDO_Qx}$ | | | $0.75 \times V_{DDO_Qx}$ | | | $0.75 \times V_{DDO_Qx}$ | | | $0.75 \times V_{DDO_Qx}$ | | | |
| | | $V_{DDO_Qx} = 1.8V \pm 5\%$ | $0.65 \times V_{DDO_Qx}$ | | | $0.71 \times V_{DDO_Qx}$ | | | $0.75 \times V_{DDO_Qx}$ | | | $0.75 \times V_{DDO_Qx}$ | | | |
| | | $V_{DDO_Qx} = 1.5V \pm 5\%$ | $0.61 \times V_{DDO_Qx}$ | | | $0.66 \times V_{DDO_Qx}$ | | | $0.70 \times V_{DDO_Qx}$ | | | $0.72 \times V_{DDO_Qx}$ | | | |
| | | $V_{DDO_Qx} = 1.2V \pm 5\%$ | $0.56 \times V_{DDO_Qx}$ | | | $0.59 \times V_{DDO_Qx}$ | | | $0.63 \times V_{DDO_Qx}$ | | | $0.66 \times V_{DDO_Qx}$ | | | |
| V_{OL} | Output Low Voltage | $V_{DDO_Qx} = 3.3V \pm 5\%$ | | | $0.29 \times V_{DDO_Qx}$ | | | $0.25 \times V_{DDO_Qx}$ | | | $0.25 \times V_{DDO_Qx}$ | | | $0.25 \times V_{DDO_Qx}$ | V |
| | | $V_{DDO_Qx} = 2.5V \pm 5\%$ | | | $0.32 \times V_{DDO_Qx}$ | | | $0.27 \times V_{DDO_Qx}$ | | | $0.25 \times V_{DDO_Qx}$ | | | $0.25 \times V_{DDO_Qx}$ | |
| | | $V_{DDO_Qx} = 1.8V \pm 5\%$ | | | $0.39 \times V_{DDO_Qx}$ | | | $0.33 \times V_{DDO_Qx}$ | | | $0.30 \times V_{DDO_Qx}$ | | | $0.26 \times V_{DDO_Qx}$ | |
| | | $V_{DDO_Qx} = 1.5V \pm 5\%$ | | | $0.44 \times V_{DDO_Qx}$ | | | $0.38 \times V_{DDO_Qx}$ | | | $0.35 \times V_{DDO_Qx}$ | | | $0.31 \times V_{DDO_Qx}$ | |
| | | $V_{DDO_Qx} = 1.2V \pm 5\%$ | | | $0.50 \times V_{DDO_Qx}$ | | | $0.46 \times V_{DDO_Qx}$ | | | $0.42 \times V_{DDO_Qx}$ | | | $0.38 \times V_{DDO_Qx}$ | |
| Z_{OUT} | Output Impedance | $V_{DDO_Qx} = 3.3V \pm 5\%$ | | 35 | | | 25 | | | 21 | | | 18 | Ω | |
| | | $V_{DDO_Qx} = 2.5V \pm 5\%$ | | 31 | | | 23 | | | 20 | | | 17 | | |
| | | $V_{DDO_Qx} = 1.8V \pm 5\%$ | | 42 | | | 31 | | | 25 | | | 21 | | |
| | | $V_{DDO_Qx} = 1.5V \pm 5\%$ | | 71 | | | 47 | | | 35 | | | 29 | | |
| | | $V_{DDO_Qx} = 1.2V \pm 5\%$ | | 101 | | | 86 | | | 66 | | | 49 | | |

- 1. $V_{SS} = 0V$, $T_A = -40^\circ C$ to $85^\circ C$.
- 2. V_{DDO_Qx} is used to refer to the appropriate V_{DDO_Qx} power supply voltage for each output (or more information, see [Table 3](#) and [Table 2](#)).
- 3. This refers to the register settings for the LVC MOS output drive strength within the device.

Table 16. Input Frequency Characteristics [1]

| Symbol | Parameter | Test Condition | Minimum | Typical | Maximum | Unit | |
|------------|-------------------------------------|-----------------------------|---|---------|------------------------|------|-----|
| f_{IN} | Input Frequency | OSCI, OSCO | Using a Crystal ^[2] | 25 | | 54 | MHz |
| | | | Over-driving Crystal Input Doubler Logic Enabled ^[3] | 25 | | 62.5 | |
| | | | Over-driving Crystal Input Doubler Logic Disabled | 50 | | 125 | |
| | | Input CLK ^{[4][5]} | Differential Mode | | | 1000 | |
| | | | Single-ended Mode | | | 250 | |
| | | GPIO | Used as Clock Input | | | 150 | |
| f_{IN} | Input Frequency | XO_DPLL | 1 | | 150 ^[6] [7] | MHz | |
| f_{SCLK} | Serial Port Clock SCLK (Slave mode) | I ² C Operation | 100 | | 1200 | kHz | |
| | | SPI Operation | 0.1 | | 50 | MHz | |

- $V_{SS} = 0V$, $T_A = -40^{\circ}C$ to $85^{\circ}C$.
- For crystal characteristics, see [Table 17](#).
- Refer to [Overdriving the XTAL Interface](#).
- For information on the signals referenced by this abbreviation, see [Table 3](#).
- For proper device operation, the input frequency must be divided down to 150MHz or less (DPLL Phase Detector maximum frequency = 150MHz).
- If the System DPLL needs to be driven with a higher frequency, one of the CLKx / nCLKx inputs can be routed via register settings to the System DPLL instead of using XO_DPLL.

Table 17. Crystal Characteristics [1]

| Parameter | Test Condition | Minimum | Typical | Maximum | Unit |
|------------------------------------|---|-------------|---------|---------|----------|
| Mode of Oscillation | | Fundamental | | | |
| Frequency | | 25 | | 54 | MHz |
| Equivalent Series Resistance (ESR) | $C_L = 18pF$, crystal frequency $\leq 40MHz$ | | | 50 | Ω |
| | $C_L = 18pF$, crystal frequency $> 40MHz$ | | | 25 | |
| | $C_L = 12pF$ | | | 50 | |
| Load Capacitance (C_L) | | | 12 | | pF |

- $V_{SS} = 0V$, $T_A = -40^{\circ}C$ to $85^{\circ}C$.

3.6 AC Electrical Characteristics

Table 18. AC Characteristics [1][2]

| Symbol | Parameter | | Test Condition | Minimum | Typical | Maximum | Unit | |
|--|---|---------------------|--|--|---------|---------|------|----|
| f _{VCO} | Analog PLL VCO Operating Frequency | | V _{DDA_X} ^[3] = 3.3V ±5% | 13.4 | | 13.8 | GHz | |
| | | | V _{DDA_X} ^[3] = 2.5V ±5% | 13.5 | | 13.9 | | |
| f _{FOD} | Fractional Output Divider Operating Frequency | | Measured with output divider set to /1 | 500 | | 1000 | MHz | |
| f _{OUT} | Output Frequency | Differential Output | | 0.0000005 | | 1000 | MHz | |
| | | LVC MOS Output | | 0.0000005 | | 250 | | |
| Δf _{OUT} | Output Frequency Accuracy ^[4] | | | | 0 | | ppb | |
| | Initial Frequency Offset ^[5] | | Switchover or Entering Holdover State | | 1 | | ppb | |
| | Output Phase Change in Fully Hitless Switching ^[6] | | Input references with phase difference < 100μs | | 350 | | ps | |
| | | | Input references with phase difference ≥ 100μs | | 1000 | | | |
| t _{sk} | Output-to-Output Skew ^{[7][8]} | | Any two differential outputs ^[9] | V _{DDO_Qx} = 3.3V ±5% | | 65 | 150 | ps |
| | | | | V _{DDO_Qx} = 2.5V ±5% | | | | |
| | | | | V _{DDO_Qx} = 1.8V ±5% | | | | |
| | | | Any two outputs configured as LVC MOS in-phase ^[10] | V _{DDO_Qx} = 3.3V ±5% | | 100 | 255 | |
| | | | | V _{DDO_Qx} = 2.5V ±5% | | | | |
| | | | | V _{DDO_Qx} = 1.8V ±5% | | | | |
| | | | | V _{DDO_Qx} = 1.5V ±5% ^[11] | | | | |
| | | | Q to nQ of same output pair, configured as LVC MOS, in-phase ^[10] | V _{DDO_Qx} = 1.2V ±5% ^[11] | | | | |
| | | | | V _{DDO_Qx} = 3.3V ±5% | | 20 | 90 | |
| | | | | V _{DDO_Qx} = 2.5V ±5% | | 20 | 130 | |
| | | | | V _{DDO_Qx} = 1.8V ±5% | | | | |
| | | | | V _{DDO_Qx} = 1.5V ±5% ^[11] | | | | |
| V _{DDO_Qx} = 1.2V ±5% ^[11] | | | | | | | | |

Table 18. AC Characteristics [1][2] (Cont.)

| Symbol | Parameter | Test Condition | | | Minimum | Typical | Maximum | Unit |
|---|---|---|-----------------------------|------------------------------|---------|---------|---------|-------|
| $t_{SK(B)}$ | Output-to-Output Skew within a Bank ^[12] | Bank 1: Q0/nQ0(FOD0), Q1/nQ1(FOD0), Q2/nQ2(FOD1, FOD5), Q3/nQ3(FOD5), Q8/nQ8(FOD5), Q9/nQ9(FOD5) | Differential _[9] | $V_{DDO_Qx} = 3.3V \pm 5\%$ | | 30 | 65 | ps |
| | | | | $V_{DDO_Qx} = 2.5V \pm 5\%$ | | 30 | 72 | |
| | | | | $V_{DDO_Qx} = 1.8V \pm 5\%$ | | | | |
| | | | LVCMOS _[10] | $V_{DDO_Qx} = 3.3V \pm 5\%$ | | 75 | 150 | |
| | | | | $V_{DDO_Qx} = 2.5V \pm 5\%$ | | | | |
| | | | | $V_{DDO_Qx} = 1.8V \pm 5\%$ | | | | |
| | | Bank 2: Q4/nQ4(FOD5), Q10/nQ10(FOD5) | Differential _[9] | $V_{DDO_Qx} = 3.3V \pm 5\%$ | | 22 | 50 | ps |
| | | | | $V_{DDO_Qx} = 2.5V \pm 5\%$ | | | | |
| | | | | $V_{DDO_Qx} = 1.8V \pm 5\%$ | | | | |
| | | | LVCMOS _{[10][11]} | $V_{DDO_Qx} = 3.3V \pm 5\%$ | | 45 | 130 | |
| | | | | $V_{DDO_Qx} = 2.5V \pm 5\%$ | | | | |
| | | | | $V_{DDO_Qx} = 1.8V \pm 5\%$ | | | | |
| Bank 3: Q5/nQ5(FOD2, FOD3), Q6/nQ6(FOD2, FOD3), Q7/nQ7(FOD3, FOD7), Q11/nQ11(FOD7) | Differential _[9] | $V_{DDO_Qx} = 3.3V \pm 5\%$ | | 35 | 90 | ps | | |
| | | $V_{DDO_Qx} = 2.5V \pm 5\%$ | | | | | | |
| | | $V_{DDO_Qx} = 1.8V \pm 5\%$ | | | | | | |
| | LVCMOS _{[10][11]} | $V_{DDO_Qx} = 3.3V \pm 5\%$ | | 55 | 130 | | | |
| | | $V_{DDO_Qx} = 2.5V \pm 5\%$ | | | | | | |
| | | $V_{DDO_Qx} = 1.8V \pm 5\%$ | | 55 | 160 | | | |
| Δt_{SK} | Temperature Variation ^[13] Output-Output | | | | | | 4 | ps/°C |
| t_{ALIGN} | Input - Output Alignment Variation ^[14] | Delay variation as shown in Figure 6 for any CLK/CLKn input pair to any Q/Qn output pair in differential mode when using internal loopback. | | | -500 | | 500 | ps |
| Δt_{ALIGN} | Temperature Variation ^[13] Input-Output | | | | | | 4 | ps/°C |

Table 18. AC Characteristics [1][2] (Cont.)

| Symbol | Parameter | | Test Condition | Minimum | Typical | Maximum | Unit | | | |
|---------------|---------------------------------------|---|---|--|--------------------------|--------------------------------|------|------|-----|----|
| t_R / t_F | Output Rise and Fall Times 20% to 80% | Differential Output ^[15] [16] | V_{DDO_Qx} ^[17] = 3.3V ±5%, 2.5V±5% or 1.8V ±5% | SWING ^[18] = 00 | 100 | 450 | ps | | | |
| | | | | SWING = 01 | | | | | | |
| | | | | SWING = 10 | | | | | | |
| | | | | SWING = 11 | | | | | | |
| | | | | LVCMOS Output ^[19] | V_{DDO_Qx} = 3.3V ±5% | TERM ^[20] = 00 | 100 | 254 | 380 | ps |
| | | | | | | TERM = 01 | 100 | 262 | 400 | |
| | | | | | | TERM = 10 | 110 | 275 | 460 | |
| | | | | | | TERM = 11 | 115 | 268 | 510 | |
| | | | | | V_{DDO_Qx} = 2.5V ±5% | TERM = 00 | 115 | 285 | 405 | ps |
| | | | | | | TERM = 01 | 120 | 293 | 470 | |
| | | | | | | TERM = 10 | 120 | 315 | 525 | |
| | | | | | | TERM = 11 | 140 | 347 | 565 | |
| | | | | | V_{DDO_Qx} = 1.8V ±5% | TERM = 00 | 205 | 417 | 590 | ps |
| | | | | | | TERM = 01 | 205 | 458 | 715 | |
| | | | | | | TERM = 10 | 230 | 459 | 800 | |
| | | | | | | TERM = 11 | 235 | 482 | 880 | |
| | | | | V_{DDO_Qx} = 1.5V ±5% ^[21] | TERM = 00 | 415 | 558 | 730 | ps | |
| | | | | | TERM = 01 | 545 | 747 | 985 | | |
| | | | | | TERM = 10 | 615 | 890 | 1145 | | |
| | | | | | TERM = 11 | 690 | 1011 | 1305 | | |
| | | | | V_{DDO_Qx} = 1.2V ±5% ^[21] | TERM = 00 | 800 | 986 | 1250 | ps | |
| | | | | | TERM = 01 | 1180 | 1416 | 1835 | | |
| | | | | | TERM = 10 | 1415 | 1715 | 2195 | | |
| | | | | | TERM = 11 | 1650 | 1980 | 2520 | | |
| odc | Output Duty Cycle | | | Differential Output | PULSE = 50% | $f_{OUT} < 500MHz$ | 47 | 50 | 53 | % |
| | | | | | | $500MHz \leq f_{OUT} < 800MHz$ | 45 | 50 | 55 | % |
| | | | | | | $f_{OUT} \geq 800MHz$ | 40 | 50 | 60 | % |
| | | | | LVCMOS | PULSE = 50% | V_{DDO_Qx} = 3.3V or 2.5V | 47 | 50 | 53 | % |
| | | V_{DDO_Qx} = 1.8V or 1.5V | 45 | | | 50 | 55 | | | |
| | | V_{DDO_Qx} = 1.2V | 42 | | | 50 | 58 | | | |
| t_{LOCK} | 1PPS Locking Time | | 17mHz loop bandwidth, phase and frequency snap enabled | | | 20 | S | | | |
| $t_{STARTUP}$ | Start-up Time ^[22] | Regulators Ready ^[23] | | | 3 | | µs | | | |
| | | Internal OTP Start-up | Synthesizer mode | | 7 | 10 | ms | | | |
| | | | DPLL mode, with a loop bandwidth setting of 300Hz ^[24] | | 1.5 | | s | | | |

Table 18. AC Characteristics [1][2] (Cont.)

| Symbol | Parameter | Test Condition | Minimum | Typical | Maximum | Unit | |
|--------|--|----------------|---------|---------|---------|------|-----|
| PSNR | Power Supply Noise Rejection ^{[25][26][27][28]} | VDDA_LC_BG | 50mVpp | | -85 | | dBc |
| | | | 100mVpp | | -80 | | |
| | | VDDA_PDCP_XTAL | 50mVpp | | -75 | | |
| | | | 100mVpp | | -70 | | |
| | | VDDO_Qx | 50mVpp | | -70 | | |
| | | | 100mVpp | | -70 | | |

1. $V_{SS} = 0V$, $T_A = -40^{\circ}C$ to $85^{\circ}C$.
2. Electrical parameters are guaranteed over the specified ambient operating temperature range, which is established when the device is mounted in a test socket with maintained transverse airflow greater than 500lfpm. The device will meet specifications after thermal equilibrium has been reached under these conditions.
3. V_{DDA_X} refers to V_{DDA_PDCP} , V_{DDA_XTAL} , V_{DDA_LC} , and V_{DDA_BG} .
4. Long-term frequency error with respect to the DPLL input reference. The typical value shown assumes the DPLL has been phase-locked to a stable input reference for at least 306 minutes (based on a 0.1mHz advanced holdover filter setting) before going into an advanced holdover state on disqualification of the input reference.
5. This parameter will vary with the quality of the reference to the system DPLL. The typical value shown assumes an ideal reference used for the system DPLL.
6. This parameter will vary with the quality of the TDC and system DPLL references. The typical value shown assumes an ideal reference is used as input to the TDC and system DPLL.
7. Defined as the time between the rising edges of two outputs of the same frequency, configuration, loading, and supply voltage
8. This parameter is defined in accordance with JEDEC Standard 65.
9. Measured at the differential cross points.
10. Measured at $V_{DDO_Qx} / 2$.
11. Using LVCMOS with $V_{DDO_Qx} = 1.5V$ or $1.2V$ will result in much larger skews and is not recommended for skew-sensitive applications.
12. Banks are defined as a list of outputs driven by a specific FOD. Results do not apply if the output is driven by a different FOD.
13. This parameter is measured across the full operating temperature range and the difference between the slowest and fastest numbers is the variation.
14. Measured from the differential cross point of the input to the differential cross point of the associated output after device is locked and input is stable. Measured using integer-related input and output frequencies.
15. Rise and fall times on differential outputs are independent of the power supply voltage on the output.
16. Measured with outputs terminated with 50Ω to GND.
17. For information on the signals referenced by this abbreviation, see [Table 3](#).
18. Refers to the differential voltage swing setting programmed into device registers for each output.
19. Measured with outputs terminated with 50Ω to $V_{DDO_Qx} / 2$.
20. Refers to the LVCMOS output drive strength (termination) setting programmed into device registers for each output.
21. This parameter has been characterized with $F_{OUT} = 50MHz$.
22. Measured from the rising edge of nMR after all power supplies have reached $> 80\%$ of nominal voltage to the first stable clock edge on the output. A stable clock is defined as one generated from a locked analog or digital PLL (as appropriate for the configuration listed) with no further perturbations in frequency expected.
23. At power-up, the nMR signal must be asserted for at least this period of time.
24. Start-up time will depend on the actual configuration used. For more information on estimating start-up time, please contact Renesas technical support.
25. Noise spur amplitude measured relative to 156.25MHz carrier.
26. Typical PSNR values specified over the modulation frequency range of 10kHz to 1MHz.
27. Injected as sinusoidal noise to the specified power rail only.
28. 0.1uF capacitor placed on modulated power rail.

Table 19. Phase Jitter and Phase Noise

| Symbol | Parameter | Conditions | Minimum | Typical | Maximum | Unit |
|------------------|---|--|---------|---------|---------|----------|
| tjit(Φ) | Random Phase Jitter (12kHz to 20MHz, 50MHz Crystal, Clock Generator Mode, 13750MHz APLL VCO Frequency) | 156.25MHz (IOD) | - | 107 | 130 | fs (RMS) |
| | | 312.5MHz (IOD) | - | 103 | 120 | |
| | | 106.25MHz (FOD) | - | 147 | 165 | |
| | | 100MHz (FOD) | - | 176 | 192 | |
| tjit(Φ) | Random Phase Jitter (12kHz to 20MHz, 54MHz Crystal, Jitter Attenuator Mode with 10Hz loop bandwidth, 25MHz input from SMA-100) | 156.25MHz | - | 108 | 133 | fs (RMS) |
| | | 312.5MHz | - | 108 | 133 | |
| Φ SSB(1k) | Single Sideband Phase Noise (50MHz Crystal, Clock Generator Mode, 13750MHz APLL VCO Frequency, one IOD output enabled at 156.25MHz) | 1kHz Offset | - | -129 | - | dBc/Hz |
| Φ SSB(10k) | | 10kHz Offset | - | -136 | - | |
| Φ SSB(100k) | | 100kHz Offset | - | -145 | - | |
| Φ SSB(1M) | | 1MHz Offset | - | -153 | - | |
| Φ SSB(10M) | | 10MHz Offset | - | -157 | - | |
| Φ SSB(20M) | | 20MHz Offset | - | -158 | - | |
| Φ SSB(1k) | Single Sideband Phase Noise (50MHz Crystal, Clock Generator Mode, 13750MHz APLL VCO Frequency, one FOD output enabled at 106.25MHz) | 1kHz Offset | - | -127 | - | dBc/Hz |
| Φ SSB(10k) | | 10kHz Offset | - | -134 | - | |
| Φ SSB(100k) | | 100kHz Offset | - | -143 | - | |
| Φ SSB(1M) | | 1MHz Offset | - | -155 | - | |
| Φ SSB(10M) | | 10MHz Offset | - | -158 | - | |
| Φ SSB(20M) | | 20MHz Offset | - | -159 | - | |
| Φ SSB(1k) | Single Sideband Phase Noise (54MHz Crystal, Jitter Attenuator Mode with 10Hz loop bandwidth, 25MHz input from SMA-100, one output enabled at 156.25MHz) | 1kHz Offset | - | -126 | - | dBc/Hz |
| Φ SSB(10k) | | 10kHz Offset | - | -134 | - | |
| Φ SSB(100k) | | 100kHz Offset | - | -145 | - | |
| Φ SSB(1M) | | 1MHz Offset | - | -152 | - | |
| Φ SSB(10M) | | 10MHz Offset | - | -156 | - | |
| Φ SSB(20M) | | 20MHz Offset | - | -157 | - | |
| - | Output-output Isolation | Measured on 156.25MHz LVDS victim with 100MHz HCSL aggressor | - | -75 | - | dB |

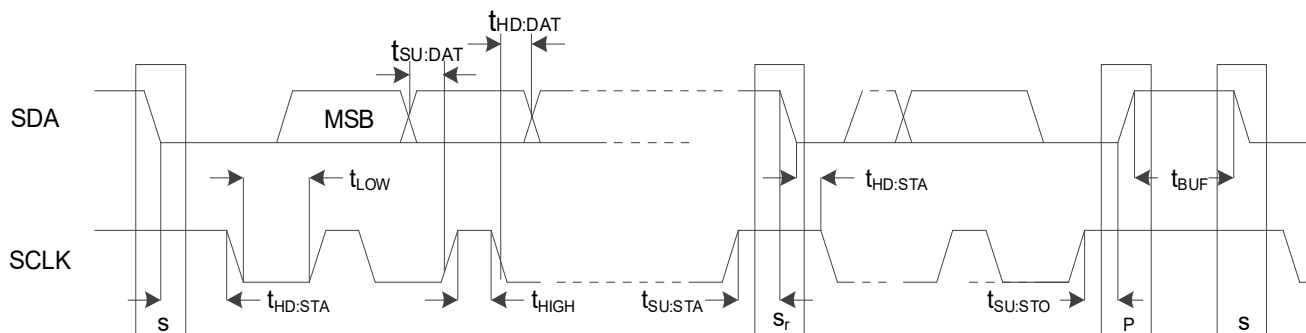
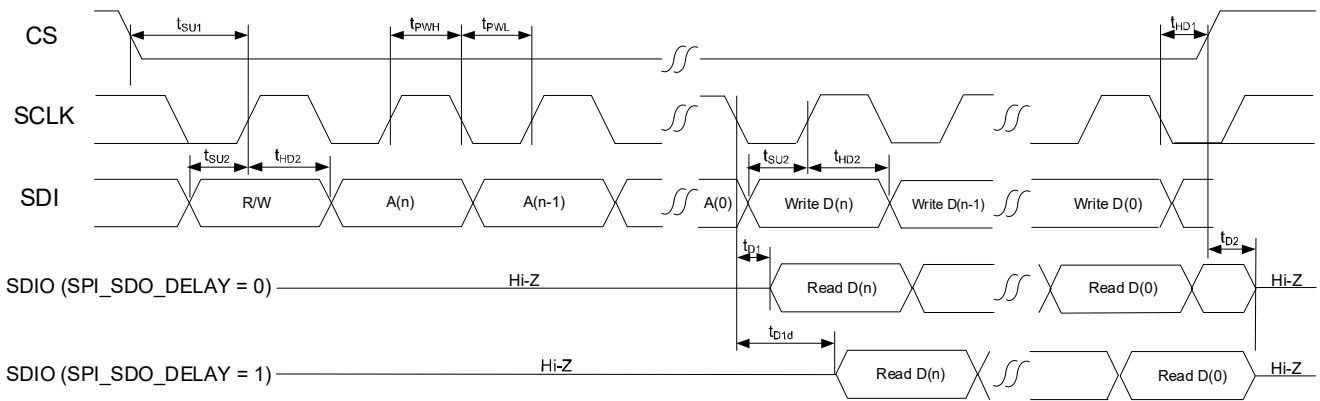

Figure 4. I²C Slave Timing Diagram

Table 20. I²C Slave Timing

| Parameter | Description | Minimum | Typical | Maximum | Unit |
|--------------|---|---------|---------|---------|------|
| f_{SCLK} | SCLK Operating Frequency | | | 1 | MHz |
| t_{LOW} | SCLK Pulse Width Low | | 130 | | ns |
| t_{HIGH} | SCLK Pulse Width High | | 9 | | ns |
| $t_{SU:STA}$ | Start or Repeat Start Setup Time to SCLK | | 6 | | ns |
| $t_{HD:STA}$ | Start or Repeat Start Hold Time from SCLK | | 18 | | ns |
| $t_{SU:DAT}$ | Data Setup Time to SCLK rising edge | | 5 | | ns |
| $t_{HD:DAT}$ | Data Hold Time from SCLK rising edge | | 0 | | ns |
| $t_{SU:STO}$ | Stop Setup Time to SCLK | | 12 | | ns |
| t_{BUF} | Minimum Time from Stop to Next Start | | 0.5 | | ns |

SPI_CLOCK_SELECTION = 0



SPI_CLOCK_SELECTION = 1

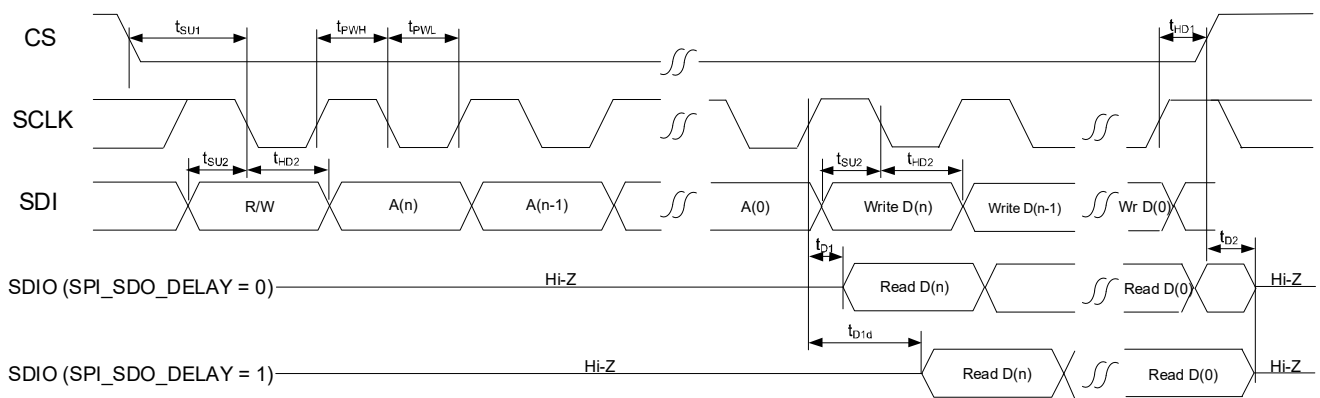

Figure 5. SPI Timing Diagram

Table 21. SPI Timing

| Parameter | Description | Minimum | Typical | Maximum | Unit |
|--------------|--|-------------------|---------|---------|------|
| f_{MAX} | Maximum operating frequency when performing only writes | | | 50 | MHz |
| t_{PWH} | SCLK Pulse Width High | 9 | | | ns |
| t_{PWL} | SCLK Pulse Width Low | 9 | | | ns |
| t_{SU1} | CS Setup Time to SCLK rising or falling edge | 4.2 | | | ns |
| t_{HD1} | CS Hold Time from SCLK rising or falling edge | 0 | | | ns |
| t_{SU2} | SDIO Setup Time to SCLK rising or falling edge | 0 | | | ns |
| t_{HD2} | SDIO Hold Time from SCLK rising or falling edge | 0.6 | | | ns |
| t_{D1} [1] | Read Data Valid Time from SCLK rising or falling edge with no data delay added | $V_{CCCS} = 3.3V$ | | 7.2 | ns |
| | | $V_{CCCS} = 2.5V$ | | 7.3 | ns |
| | | $V_{CCCS} = 1.8V$ | | 8.6 | ns |

1. Measurement performed approximately 1cm away from device pad. Observing at a greater distance on a heavily loaded trace may show slower edge rates and longer delays. This is highly dependent on PCB loading.

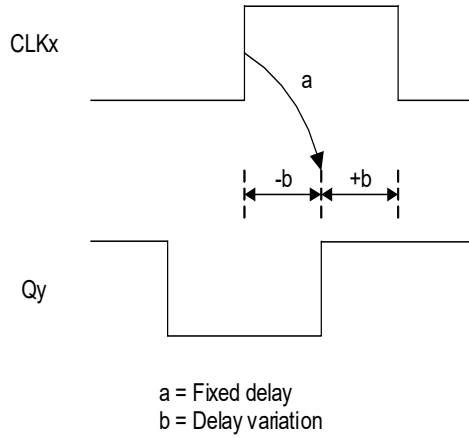

Figure 6. Input-Output Delay

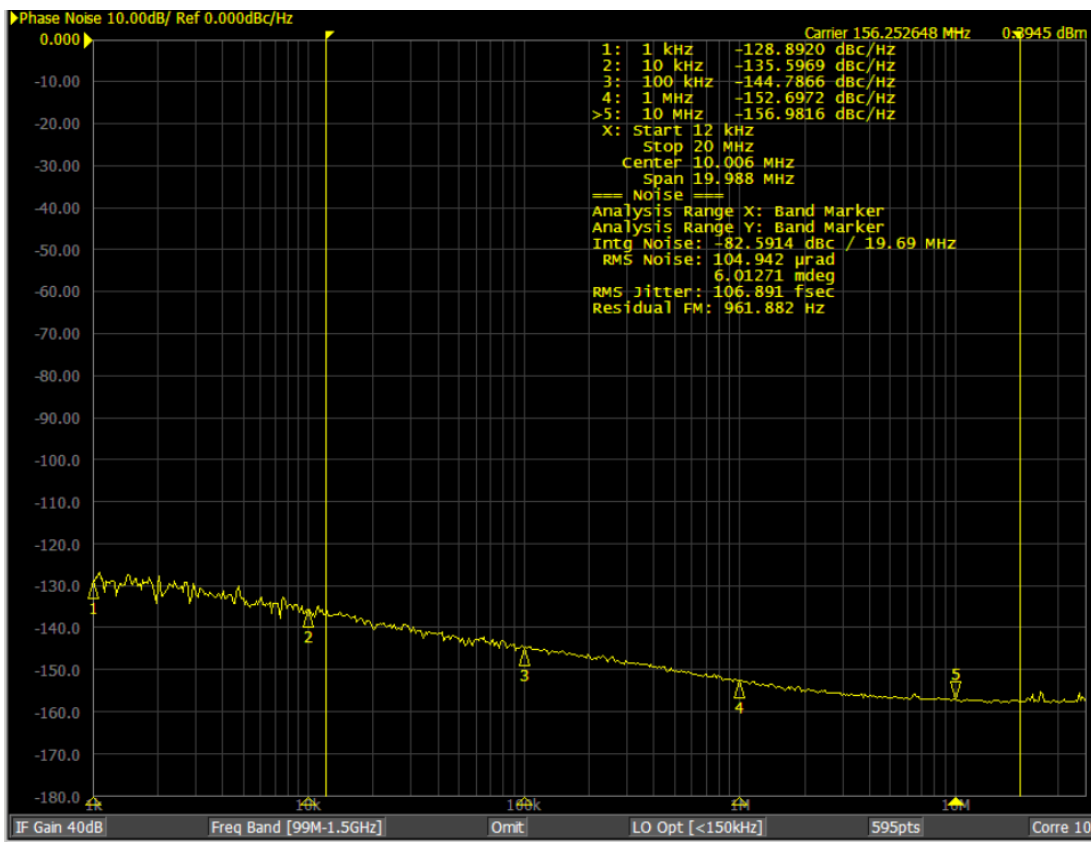

Figure 7. Phase Noise of 156.25MHz Output in Clock Generator Mode

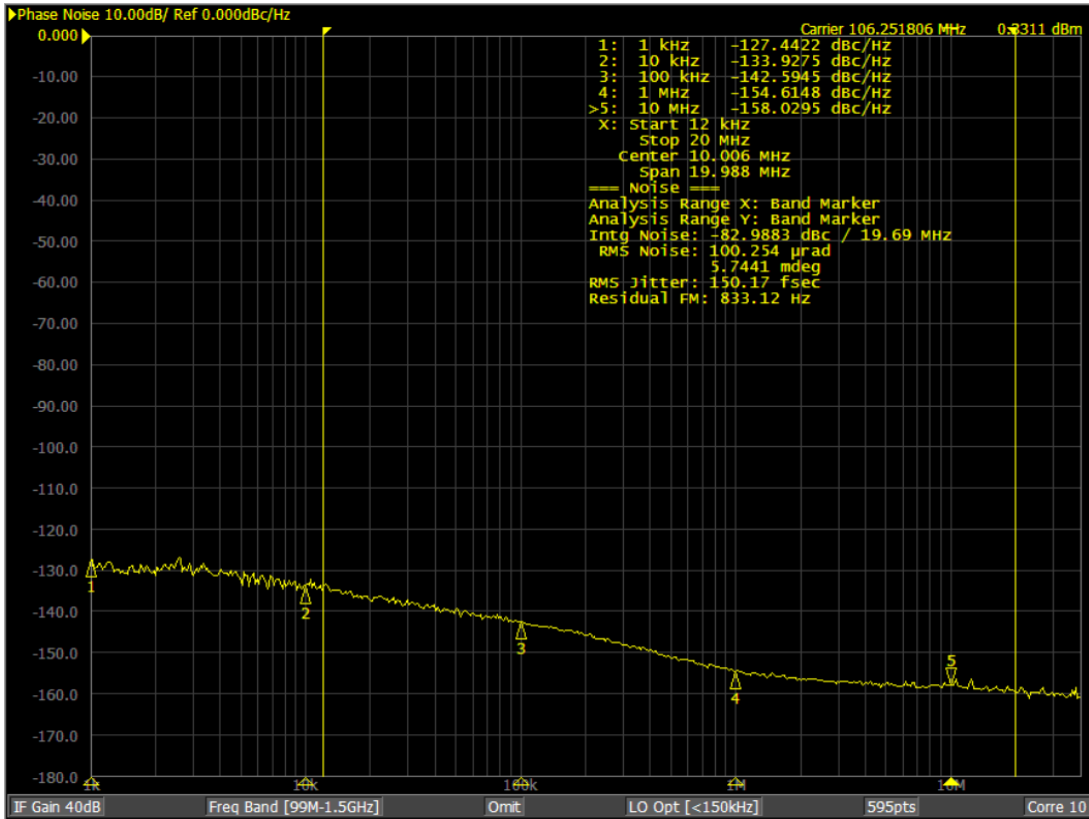

Figure 8. Phase Noise of 106.25MHz Output in Clock Generator Mode

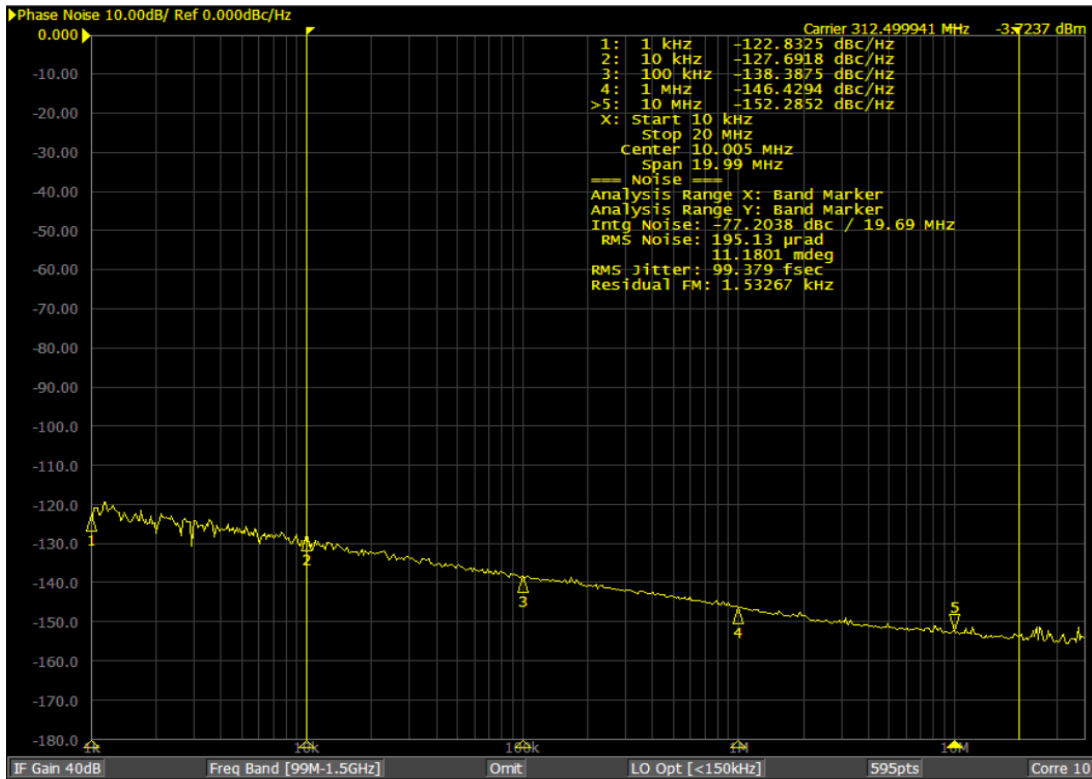

Figure 9. Phase Noise of 312.5MHz Output in Jitter Attenuator Mode

4. Functional Description

The RC32112A is a fully integrated, low-power, high-performance frequency synthesizer with jitter attenuation and network synchronization capabilities. The device can be set up as either of the following:

- Clock generator, that is locked to the external crystal or oscillator and providing free-run clock outputs
- Jitter attenuator, that is locked to an external reference and providing low-jitter clock outputs when used with an external crystal or oscillator
- Network synchronizer, that is locked to an external reference and using combo bus between DPLLs to meet the band-pass function needed for the telecom boundary clock compliance as per ITU-T G.8273.2 T-BC

The device is optimized to deliver excellent phase noise as required for driving up to 28Gbps Ethernet PHYs, ASICs or FPGAs in 10G, 25G, 40G, 100G, 200G, or 400G switch line cards and switch fabric cards. The RC32112A supports JEDEC JESD204B/C for converter synchronization and SyncE for network-based synchronization.

4.1 Clock Generator Mode

The RC32112A can be set in Clock Generator mode by completing the following steps:

1. DPLL/DCO and System DPLL are powered down.
2. CLK0-4 and GPIO0, GPIO3, GPIO9 are unused for reference clock inputs.
3. APLL is locked to external crystal or oscillator and provides high-frequency clocks to FOD_0, FOD_1, FOD_2, FOD_3, FOD_5, and FOD_7.
4. Free-run clock outputs are generated from FOD_0, FOD_1, FOD_2, FOD_3, FOD_5, or FOD_7, and each FOD can be independently set to integer or fractional divide values.

Note: Up to six unrelated clock frequency domains can be achieved.

4.2 Jitter Attenuator or Synchronizer Mode

The RC32112A can be set in Jitter Attenuator or Synchronizer mode by completing the following steps:

1. CLK0-4 and GPIO0, GPIO3, GPIO9 are used for reference clock inputs.
2. APLL is locked to external crystal or oscillator and provides high-frequency clocks to SYS_DPLL and FOD_0, FOD_1, FOD_2, FOD_3, FOD_5, and FOD_7.
3. System DPLL locks to external oscillator or TCXO or OCXO.
4. DPLL/DCO uses FOD_0 and FOD_1 to be synchronized and locked to the chosen reference clock input.
5. Clock outputs, generated from synchronized DPLL/DCO, are generated from FOD_0
6. Clock outputs, generated from free-run APLL or from System DPLL or from synchronized DPLLs/DCOs, are generated from FOD_2, FOD_3, FOD_5, and FOD_7, which can be set to integer or fractional divider values.

Note: Up to six unrelated clock frequency domains can be achieved.

4.3 Power-Up, Configuration and Serial Interfaces

The RC32112A can be powered up and configured in three ways:

- From internal non-volatile memory using OTP user configurations (UserCfgs)
- From its slave serial interface
- From an external I2C EEPROM

The RC32112A supports three slave serial interfaces: I2C, SPI, and SMBUS, and one serial master interface (I2C). These interfaces share the same pins, so only one is available at a time. Additionally, all of the device GPIO pins are sampled at the rising edge of the nMR (master reset) signal and some of them can be used in setting the initial configuration.

4.4 Input Clocks

The RC32112A supports one crystal/reference input that is used as a reference to the analog PLL (APLL). Up to five differential or thirteen single-ended clock inputs can be used as a reference to the digital PLL (DPLL) and support hitless reference switching. GPIO0, GPIO3, and GPIO9 can alternately be set as reference clock inputs in Jitter Attenuator mode.

4.4.1 Crystal/Oscillator Input

The crystal input supports crystal frequencies of 25 to 54MHz with a recommended load capacitance of 12pF. The crystal input can be overdriven with differential or single-ended inputs with proper external terminations. The supported frequency range is 25 to 62.5MHz when doubler logic for APLL is enabled, and 50 to 125MHz when doubler logic for APLL is disabled. An available LOS monitor detects the loss of signal on crystal input.

4.4.2 XO_DPLL Input

The XO_DPLL input supports frequencies of 1 to 150MHz when driven by an external oscillator, TCXO, or OCXO. An available LOS monitor detects the loss of signal on XO_DPLL input.

4.4.3 Reference Clock Inputs

There are five differential reference clock inputs that support differential or single-ended CMOS logic levels without external terminations. If set to single-ended type, each differential input turns into two single-ended inputs. Additionally, GPIO0, GPIO3, and GPIO9 can each be individually programmed to act as a single-ended input. Internal biasing is available for AC-coupled applications. The five clock inputs can be left floating when unused. An available LOS monitor detects the loss of signal on reference clock inputs.

4.5 Clock Input Monitors

Each DPLL clock input (CLKIN0, CLKIN0B, CLKIN1, CLKIN1B, GPIO0, GPIO3, and GPIO9) has LOS, activity, and frequency monitoring.

- The LOS monitor detects missing edges over a window of several reference clock periods. For the best accuracy, it is recommended to program the window to be equal to at least eight times that of the measuring clock period.
- The frequency monitor can be configured to measure the reference over a nominal 5ms time window in order to achieve ~1ppm granularity.
- The frequency monitor can be configured to measure the reference over a nominal 0.4s time window in order to achieve ~12ppb granularity.

4.6 Clock Input Monitor

The APLL input is monitored for Loss of Signal (LOS). The LOS monitor detects missing edges over a window of several reference clock periods. For the best accuracy, it is recommended to program the window to be equal to at least eight times that of the measuring clock period.

4.7 APLL

The APLL is an integer LC-VCO based PLL with an operating range from 13.4 to 13.9GHz. The crystal or oscillator input clock is used to drive the APLL, and can be frequency doubled for increased performance. The APLL is temperature compensated for utmost frequency stability. The high-frequency clock output from the APLL is provided to each of the six fractional output dividers (FOD_0, FOD_1, FOD_2, FOD_3, FOD_5, FOD_7).

4.7.1 APLL Lock Detector

The APLL lock detector indicates whether the APLL is locked to a functioning crystal or reference input by monitoring the phase errors. Lock status is available on a GPIO pin or in the register map.

4.8 System DPLL

The System DPLL uses a high-frequency clock input from the APLL and forms a fractional-N DPLL architecture that is locked to the oscillator, or TCXO or OCXO. The System DPLL generates an internal system clock that is used by the reference monitors and other digital circuitry in the device. If the reference provided to the System APLL meets the stability and accuracy requirements of the intended application then the System DPLL can free run and a System DPLL reference is not required.

Alternatively, the System DPLL can be locked to an external reference that meets the stability and accuracy requirements of the intended application. The System DPLL can accept a reference from the XO_DPLL. The frequency information from the System DPLL can be shared with the DPLLs and with each of the six fractional output dividers (FOD_0, FOD_1, FOD_2, FOD_3, FOD_5, and FOD_7).

4.9 DPLL

To operate in Jitter Attenuator or Synchronizer mode, FOD_0 and FOD_1, which receives its high-frequency clock input from the APLL, is used as a DCO and forms a fractional-N DPLL architecture that is locked to the chosen reference clock input. The APLL locks to an input clock from a crystal or a crystal oscillator and generates an output clock in the range of 13.4 to 13.9GHz, and FOD_0 & FOD_1 each generates an output clock in the range of 500MHz to 1GHz. The FOD_0 and FOD_1 each acts as a digital controlled oscillator (DCO) and is dynamically controlled by the DPLL. The DPLL each also uses the FOD_0 and FOD_1 output clocks to generate the fractional divided DPLL feedback clock. The DPLLs fractional feedback dividers, which are comprised of 48-b numerator and 48-b denominator, are static during normal operation.

4.10 DPLL Operating Modes

All DPLLs within the RC32112A are exactly the same. The only difference with the System DPLL channel is that it is not connected directly to any output stages. One channel of the DPLL is shown in the following figure.

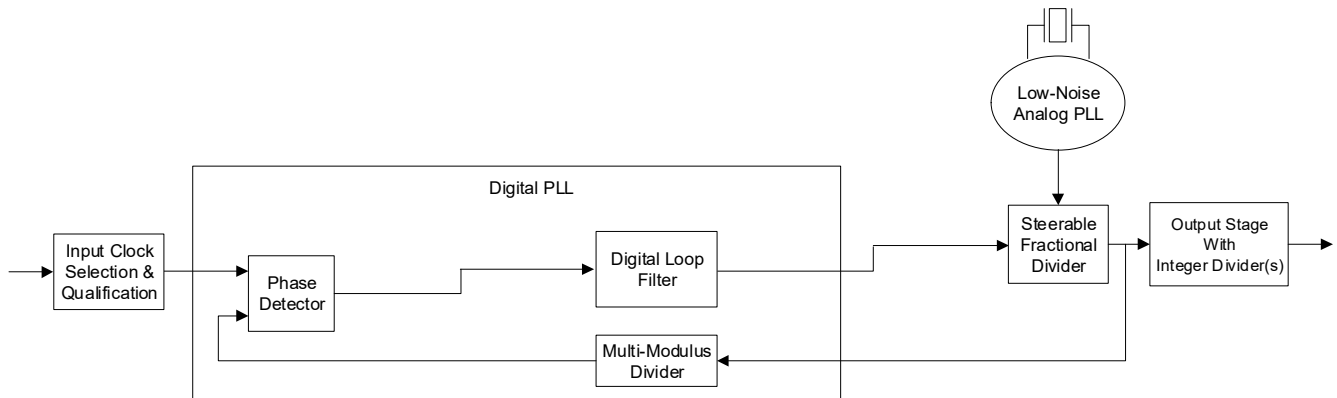

Figure 10. DPLL Channel

The DPLL operating mode operation can be set to automatic, forced locked, forced free-run, and forced holdover. They can be controlled by setting the appropriated bits in the DPLL mode register. When the DPLL is set to automatic, then an internal state machine will control the states automatically. The automatic state machine is shown in [Figure 11](#).

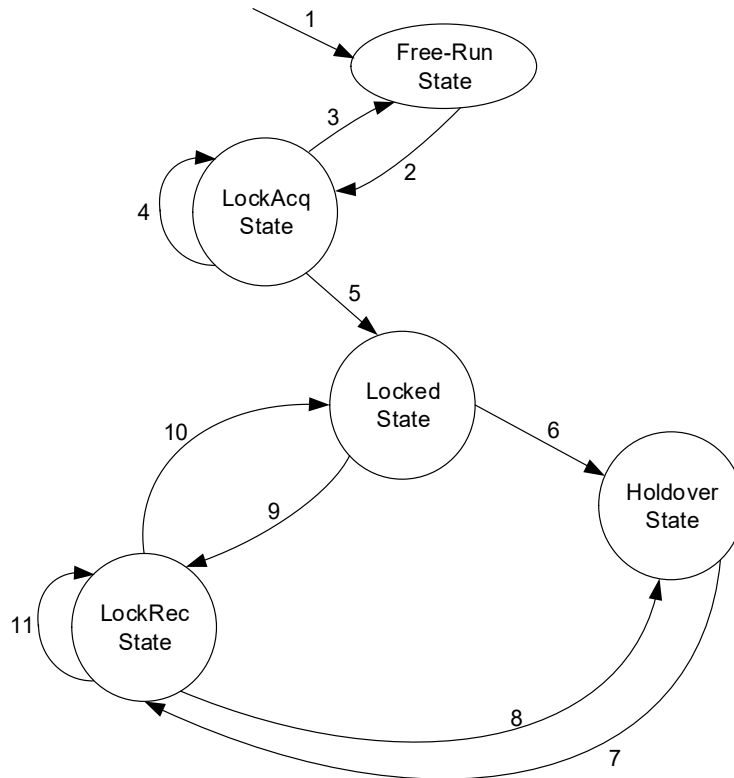

Figure 11. DPLL Automatic State Machine

In [Figure 11](#), the changes of state are based on:

1. Reset, the device enters Free-Run state.
2. Once an input clock is qualified and it is selected: enter the LockAcq state.
3. If the DPLL selected input clock is disqualified AND no qualified input clock is available: go back to Free-Run state.
4. DPLL switches to another qualified clock: remain in LockAcq state.
5. The DPLL locks to the selected input clock: enter Locked State.
6. The DPLL selected input clock is disqualified AND No qualified input clock is available: enter Holdover state.
7. A qualified input clock is now available: enter LockRec state.
8. If the DPLL selected input clock is disqualified AND no qualified input clock is available: go back to Holdover state.
9. The DPLL switches to another qualified clock: enter LockRec state.
10. The DPLL locks to the selected input clock: go to Locked state.
11. The DPLL switches to another qualified clock: remain in LockRec state.

In items 4, 9, and 11, the DPLL switches to another qualified clock due to the selected input clock being disqualified, or the device is set to revertive mode and a qualified input clock with a higher priority becomes valid, or the device is set to Forced selection to another input clock.

4.10.1 Free-Run Mode

In Free-Run mode the DPLL synthesizes clocks based on the system clock (crystal oscillator) and has no influence from a current or a previous input clock.

Combo mode can be used with Free-Run mode. In that case the input clock of the combo master affects the combo slave's free-Run frequency.

4.10.2 Locked Mode

In Locked mode, the DPLL is synchronized to an input clock. The frequency and phase of the output clock track the DPLL selected input clock. The bandwidth (BW) and damping factor are programmable, and are used by the DPLL when locked to an input reference. Table 22 includes some common bandwidth settings and their associated applications.

Table 22. DPLL Bandwidth

| DPLL Bandwidth ^[1] | Description |
|-------------------------------|--|
| 92.6 MHz | GR-253 stratum 3, SMC and G.8262 EEC-option 2 BW <0.1Hz G.8273.2 $0.5 \leq BW \leq 0.1$ |
| 278 MHz | |
| 556 MHz | |
| 1.11 Hz | G.8262 EEC-option 1 $1 \leq BW \leq 10$, GR-1244 stratum 3 BW < 3Hz |
| 2.22 Hz | G.8262 EEC-option 1 $1 \leq BW \leq 10$, GR-1244 stratum 3 BW < 3Hz |
| 4.45 Hz | G.8262 EEC-option 1 $1 \leq BW \leq 10$ |
| 8.89 Hz | G.8262 EEC-option 1 $1 \leq BW \leq 10$ |
| 17.8 Hz | |
| 35.6 Hz | |
| 71.2 Hz | |
| 94.4 Hz | |
| 142 Hz | |
| 285 Hz | G.8251 (OTN) |
| 333 Hz | |
| 571 Hz | |
| 11.4 KHz | |
| 12.1 KHz | Jitter attenuators and Clock generators |

1. Values shown are the nominal loop bandwidths that will be provided by the DPLL. Data entry via registers uses a different format and will result in the nearest value in this table that is less than the requested value in the registers.

4.10.3 Holdover Mode

If all the input clocks for a particular DPLL become invalid, then that DPLL will enter holdover state.

In holdover mode, the DPLL uses stored frequency data acquired in Locked mode to control its output clocks. There are several programmable modes for the frequency offset acquisition method; it can use the frequency offset just before it entered holdover state (simple holdover), or a previously stored post-filtered frequency offset (advanced holdover).

For the advanced holdover mode, the holdover value can be post filtered and is stored in two registers at a programmable rate while the DPLL is in locked state. When the DPLL enters the advanced holdover mode, the oldest register value is restored into the integrator inside the DPLL. The rate at which the holdover registers are updated is programmable between 0 and 63 s in steps of 1s.

Note: For the advanced holder function to operate correctly, the DPLL must have been in a locked state for multiples of the update rate before a holdover occurs or the advanced holdover values will not have settled to accurate values before being used.

The DPLL can also be forced into the holdover mode. If the forced holdover mode is used, then the DPLL will stay in holdover even if there are valid references available for the DPLL to lock to.

4.10.4 Manual Holdover Mode

In Manual Holdover mode, the DPLL state machine is forced into the Holdover state, but frequency offset is set by the DPLL manual holdover value register bits under user control.

4.11 DPLL Input Clock Qualification and Selection

The Digital PLL (DPLL) can use any of the inputs as its reference. There are several options for controlling how the DPLL selects which input to use at any moment in time. Whether a specific input is qualified for use at any time is based on the reference monitors. The DPLL_REF_MODE registers allow the DPLL to be set in any of the modes shown in the following table. There is an independent reference selection process for the DPLL.

Table 23. DPLL Reference Mode

| DPLL_ref_mode[3:0] | Description |
|--------------------|---------------------------------|
| 0000 | Automatic input clock selection |
| 0001 | Manual input clock selection |
| 0010 | GPIO |
| 0011 | Slave |
| 0100 | GPIO_Slave |
| 0101 - 1111 | Reserved |

4.11.1 Automatic Input Clock Selection

If automatic input clock selection is used, then the input clock selection is determined by the input clock being valid, the priority of each input clock, and the input clock configuration.

Each input can be enabled or disabled by setting register bits. If the input is enabled and reference monitors declare that input valid, then that input is qualified to be used by the DPLL. Within all the qualified inputs, the one with the highest priority is selected by the DPLL. The input clock priority is set by setting the appropriate bits in the DPLL_REF_PRIORITY registers. If a user prefers to designate several inputs as having the same priority, then an additional table allows several outputs to be placed in a group of equal priority.

4.11.2 Manual Input Clock Selection via Register or GPIO

If manual input clock selection is selected then the DPLL will lock to the input clock indicated by register bits or by selected GPIO pins. The results of input reference monitoring do not affect the clock selection in manual selection mode. If the DPLL is locked to an input clock that becomes invalid, then the DPLL will go into holdover even in the case where there are other input clocks that are valid.

4.11.3 Slave or GPIO Slave Selection

This mode of clock selection is used when the RC32112A is acting as an inactive, redundant clock source to another timing device. The other device is the master and the RC32112A is the slave. When Slave mode is selected via registers, a specific input (from the master timing device) is also indicated. That input and only that input is used in this mode. GPIO Slave mode involves the same configuration settings as if the device was a master, but a GPIO input is used to tell this device that it is now the slave and to switch to and monitor the designated input only.

4.12 DPLL Switchover Management

4.12.1 Revertive and Non-Revertive Switching

All DPLLs support revertive and non-revertive switching, with the default being non-revertive. During the reference selection process, a DPLL selects the valid reference with the highest priority then the DPLL locks to that input clock. In case of non-revertive switching, the DPLL only switches to another higher priority reference if the current

reference becomes invalid. Non-revertive switching minimizes the amount of reference switches and therefore is the recommended mode.

If revertive switching is enabled and a higher priority clock becomes valid, then the DPLL will switch to that higher priority input clock unless that higher priority clock is designated as part of the same group (i.e., should be considered of equal priority).

4.12.2 Hitless Reference Switching

All DPLLs support Hitless Reference Switching (HS). HS is intended to minimize the phase change on the output clock when switching between input sources that may have different phases. When a DPLL switches input with HS enabled, it will first go into an internal holdover state (but not signal that externally), then the phase offset of the newly selected input clock with respect to the previous clock will be measured. The device then automatically compensates for the measured phase offset resulting in minimal disruption to the phase of the DPLL output clock.

The HS operation for a particular DPLL is triggered if either one of the following conditions occurs:

- DPLL is locked to an input clock and switches to a different input clock
- DPLL exits from Holdover mode
- There are several additional cases where hitless reference switching can be used in synchronization applications with physical and/or packet clocks. For more information about specific applications, contact [Renesas](#).

For the two conditions, the maximum phase transient on the DPLL output clock with HS on is 250ps. Hitless reference switching can be enabled or disabled through register settings.

For 1PPS input clocks, if they have up to 100ms of phase difference between them, then the maximum phase transient on the DPLL output 1PPS clock is 250ps with HS on. If they have between 100ms and 0.5s of phase difference between them, then the maximum phase transient on the DPLL output 1PPS clock is 1ns with HS selected.

4.12.3 Phase Slope Limiting

Phase Slope Limiting (PSL) can be enabled and independently programmed for each of the DPLLs. PSL is particularly useful in the initial locking to an input or during switchover between clock inputs. If PSL is enabled, then the rate of change of phase of the output clock is limited by the DPLL. The PSL settings for the device are very flexible, allowing any slope from 1ns/s to 65.536ms/s with a granularity of 1ns/s, including the values needed to meet telecom standards as shown in [Table 24](#).

Table 24. Some Key DPLL Phase-Slope Limits Supported

| DPLL PSL | Description |
|---------------|--|
| unlimited | Limited by DPLL loop bandwidth setting |
| 61 μ s/s | Telcordia GR-1244 ST3 |
| 7.5 μ s/s | G.8262 EEC option 1, G.813 SEC option 1 |
| 885 ns/s | Telcordia GR-1244 ST2, ST3E, and ST3 (objective) |

4.12.4 DPLL Frequency Offset Limit Setting

Each DPLL has an independent setting to limit its maximum frequency range. This setting is used in conjunction with the advanced reference monitoring to provide pull-in / hold-in limit enforcement as required in many telecom standards. It will also limit the frequency deviation during locking, during holdover, and while performing switchovers. This limit must be set wide enough to cover the expected frequency range of the input when locking.

4.12.5 DPLL Fast Lock Operation

Each DPLL can also support a Fast Lock function. There are four options the user can choose from to perform the fast lock:

1. Frequency Snap
2. Phase Snap
3. Open-loop phase pull-in (mutually exclusive with Phase Snap)
4. Wide Acquisition Bandwidth

Any of the options can be independently enabled or disabled, and selected to be applied when the DPLL is in either the LOCKACQ state or the LOCKREC state. Although the options are mutually exclusive, the order of precedence is as listed (with frequency snap being the highest).

The frequency and phase snap options are recommended for locking to mid-kHz-range input clocks or lower. For frequency snap, the RC32112A will measure the input clock from the current DPLL operating frequency, determine an approximate frequency offset, and digitally write that directly to the steerable FOD block, causing the output frequency to snap directly to the correct output frequency. The frequency snap can be optionally limited using a Frequency Slope Limit (FSL). For the phase snap and the open loop phase pull-in options, the measurement is used to determine the phase offset. With phase snap, the phase is snapped to the correct value; with open loop pull-in, the DPLL's PFD and LPF are temporarily isolated to allow for an unfiltered phase pull-in to the correct value. The combination of these methods will achieve lock very quickly but there may be severe disruptions on the output clock while locking occurs, which is mainly due to the frequency/phase snaps.

The wide acquisition bandwidth option uses the DPLL in a normal operating mode, but with temporary relaxation of items like DPLL loop bandwidth, phase slope limits (PSL) or damping factor until lock is achieved. At that point, the normal DPLL limits are resumed. The user can control what limits are to be applied. In addition, for LOCKACQ state only, the DPLL's bandwidth may be temporarily opened to its maximum for a short duration of time (in ms); with the temporary phase slope limit still being applied. This pre-acquisition option is applied before the wide acquisition bandwidth option. These methods are recommended for higher frequency signals because it results in fewer perturbations on the output clock. It also allows the user to trade off the level of changes on the clock during the locking process versus the speed of locking.

4.13 Digitally-Controlled Oscillator Operation via External Control

The DPLL channel can be operated as an externally-controlled DCO. There are several different control methods that can be used depending on the application needs. Each is described individually in the following sub-sections. Phase and/or frequency updates will be calculated using external methods and written into the RC32112A over the serial port.

4.13.1 Write-Frequency Mode

When the DPLL channel is in this mode, a Frequency Control Word (FCW) is used to adjust the frequency output of the DCO (by steering the FOD) and the phase detector and loop filter are essentially bypassed. All the filtering is done by an external device and the frequency offset written into the Write Frequency Configuration register is passed on directly to the output clocks, as displayed in Figure 12. When applied, the FCW will not cause any missing pulses or glitches in the output clock, although a large frequency jump may cause issues with devices receiving this clock. The output will remain at this frequency until a new FCW is written.

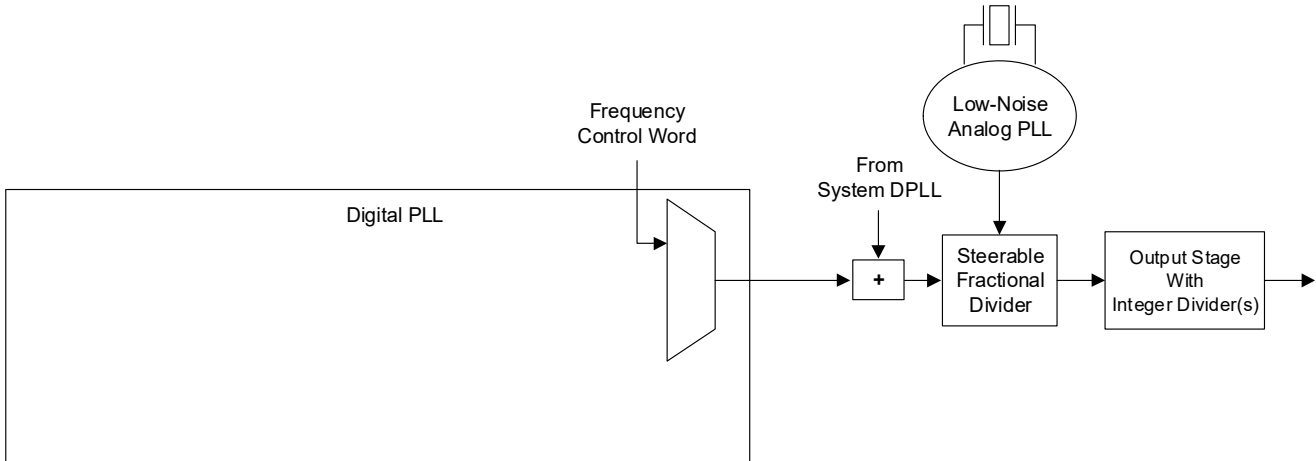

Figure 12. External DCO Control via Frequency Control Word

The FCW is a 42-bit 2's-complement value. The FCW has a granularity of 1.11×10^{-10} ppm and a full range of +244.20 ppm to -244.08 ppm of the nominal DCO frequency. A positive value will increase the output frequency and a negative one will decrease the output frequency. The formula for calculation of the FCW from the fractional frequency offset (FFO) is:

$$FCW = \left(1 - \frac{1}{\left(1 + \frac{FFO}{10^6} \right)} \right) \times 2^{53}$$

Where,

FFO = Fractional Frequency Offset, in ppm

FCW = Frequency Control Word (Positive or Negative Integer)

The value resulting from the above calculation must be converted to a 42-bit 2's complement value and then sign-extended to 48 bits to be written into the register.

Write frequency mode can be used to make phase changes on the output. For fine resolution, phase changes are done by controlling the DCO's frequency. Coarse phase adjustments should be done by snap-alignment method by using the Phase Offset registers. Using the Phase Offset registers is referred to as the snap-alignment method since the output will snap directly to that new phase rather than moving smoothly to it over time. The snap-alignment method provides fast coarse phase alignments and therefore should be used to bring the phase close to the desired value, and then use the DCO in write frequency mode to fine tune it. Since write frequency mode is changing the frequency, the phase will move smoothly over time without any jumps.

4.13.2 Increment / Decrement Registers and Pins

The DCO frequency update can also be done by applying a preset frequency offset value to be added or to be subtracted from a cumulative FCW value. The cumulative FCW value behaves as described in the previous section.

After the individual frequency offset values are configured for all applicable DCOs, then a single 16-bit register can be written over the serial port and cause an increment or decrement frequency offset to be applied to one or more DCOs with a single register access. Subsequent accesses to this register can apply additional frequency offsets to any or all DCOs.

Alternatively, one or more GPIO pins can be configured to perform the increment or decrement frequency offset function on a specific DCO. For information on how to configure the GPIOs, see [General Purpose Input/Outputs \(GPIOs\)](#).

4.13.3 Write-Phase Mode

In this mode of operation for the DPLL channel (see [Figure 13](#)), the Phase Control Word (PCW) is written by the external control logic over the serial port to directly control the DCO phase with hardware-controlled bandwidth (e.g., 0.1Hz per G.8273.2) and phase slope limiting. In this mode, the DPLL loop bandwidth and the phase slope limiting are programmable and will affect the output phase as it is adjusted.

The PCW applied to the Digital Loop Filter is equivalent to applying a phase error measured by the on-chip Phase / Frequency Detector to the Digital Loop Filter when the DPLL is operating in closed loop. The update rate needs to be at least 60 times the loop filter bandwidth. As an example, for 0.1Hz, the update should be greater than 6Hz. The rate of adjustment of phase on the DCO output is controlled by Digital Loop Filter settings. For information on configuring related DPLL parameters such as loop bandwidth and phase slope limiting, see [DPLL Operating Modes](#). This method allows a better control of the output clock since all parameters are controlled in hardware. This makes it easier to meet telecom specifications such as G.8273.2 (G.8273.2 specifies the T-BC bandwidth to be between 0.05 and 0.1Hz). This change will not cause any missing pulses or glitches in the output clock. Also, because the output frequency is changed only at a rate determined by the loop filter, this should not cause any issues, if properly configured, with devices receiving this clock.

Note: The PCW must be reduced over time or the DPLL will continue to adjust the DCO frequency to remove the “phase error”. This can be adjusted by external software.

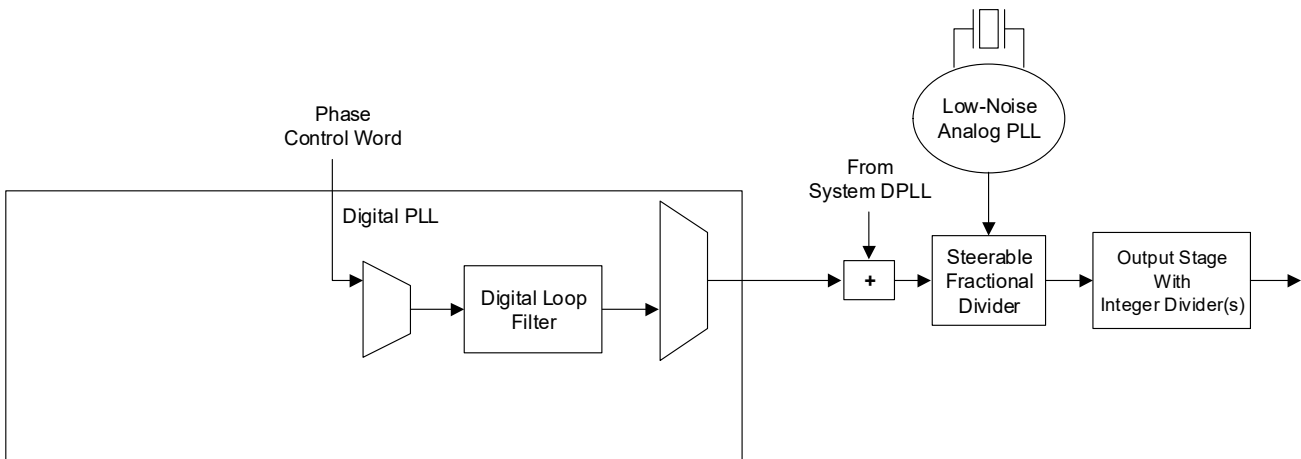

Figure 13. External DCO Control via Phase Control Word

To assist in the above, there is an optional timer associated with the PCW. This allows a phase control word to be applied for a limited period of time after which it will automatically be reset to zero or be placed into holdover by the RC32112A, and therefore it will avoid the DCO continuing to apply the phase adjustment indefinitely until it reaches its tuning range limits. The timer value is a 16-bit integer that has a granularity of 1 millisecond and a full range of up to 65.535 seconds.

The PCW is a 32-bit 2’s-complement value. The resolution of the PCW is 50ps and the range is ± 107.3741824 ms. Writing a positive value will result in the output frequency getting faster. This will shorten the clock periods, moving the clock edges to the left as seen on an oscilloscope. A negative value will slow the output frequency.

4.13.4 Adjusting Phase while in Closed Loop Operation

There may be usage scenarios that require adding a phase offset from an external software-controlled process to an output clock that is locked to an input clock. That function can also be supported as shown in Figure 14. In this mode, the amount of phase offset needed consists of two components. The first is dependent on which input the DPLL is locked to. So a phase offset register is provided for each input to allow individual offsets to be specified per-input. The second part of the phase offset configuration is for each DPLL. There is a register for each DPLL that allows for another offset value to be specified that is independent of which input is active. The actual Phase Offset Value applied will be calculated by the RC32112A using the per-input phase offset value for the currently active input summed with the phase offset value for the DPLL channel. During input reference switching, this value will be automatically recalculated at any switchover and applied as shown. Note that if an input is used on multiple DPLL channels, it may not be possible to maintain unique values per-input-per-DPLL. The calculated offset value is then summed with the measured phase error for that channel (phase difference between input reference and feedback value) to drive the DPLL to the desired phase.

The Phase Offset Value applied to the Digital Loop Filter is equivalent to applying a phase error measured by the on-chip Phase / Frequency Detector to the Digital Loop Filter when the DPLL is operating in closed loop.

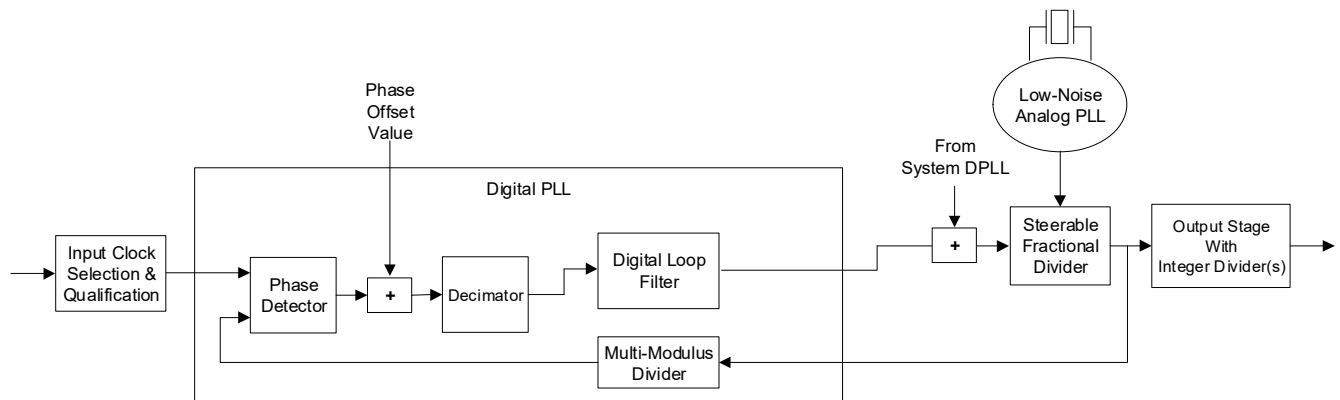

Figure 14. Phase Control in Closed Loop Operation

4.14 DPLL Lock Detector

The DPLL lock detector declares lock when the phase from the phase detector remains within a programmable range for a programmable time interval both of which are set in the register map. This indicates that the DPLL is locked to the reference clock input. If the phase detector output is below the lock threshold for half of the programmed lock interval, the internal lock signal is asserted and the normal loop filter bandwidth and damping applied to the DPLL's loop filter instead of the acquire filter settings.

4.15 Output Dividers

The RC32112A provides six fractional output dividers (FOD) and 12 integer output dividers (IOD).

4.15.1 Integer Output Dividers

All 12 IODs are identical and derive their input clock from the output of either of the six FODs. Each IOD uses a 32-bit divider to provide output frequencies from 0.5Hz to 1GHz. Changing IOD values results in an immediate change to the new frequency. Glitchless squelch and release of the IOD clock is supported. When enabled, this mimics a gapped clock behavior when an IOD frequency is changed.

4.15.1.1 SYSREF Generation

The RC32112A supports continuous mode SYSREF generation within each IOD. Additional coarse delay adjust is available per IOD channel with a step size of one FOD output clock period.

4.15.2 Fractional Output Dividers

There are six fractional output dividers (FOD) with FOD_0 as a part of DPLL/DCO in Jitter Attenuator mode. Each FOD can divide down either the APLL VCO clock or the DPLL output clock to provide frequencies of 500MHz to 1GHz. The fractional divide value involves two unsigned integer values, representing the integer (INT) and fraction (FRAC) portion of the divide ratio. The fraction portion is an integer representing the 43-bit numerator of a fraction, where the denominator of that fraction is fixed at 2^{43} . The equation for the FOD output frequency is as follows.:

$$f_{\text{FOD}} = \frac{f_{\text{APLL}}}{\left(\text{INT} + \frac{\text{FRAC}}{2^{43}} \right)}$$

Note: Fractions that approach 0, 1, or 1/2 can result in increased phase noise on the output signal due to integer-boundary spurs. It is recommended that APLL frequency and FOD divider settings be coordinated to avoid such fractions.

4.15.2.1 Output Phase Adjustment

Fine phase adjustments of the FOD output can be performed by increasing or decreasing the frequency of operation of the FOD for a period of time. This results in the clock edges of the FOD output clock being advanced (increased FOD output frequency will move edges to the left as seen on an oscilloscope relative to some fixed reference point) or delayed (decreased FOD output frequency moves edges to the right) by some amount.

Coarse phase adjustments of the IOD output can be performed, and is the same as FOD phase adjustment but with a step size of one FOD output clock period.

4.15.2.2 Digital Controlled Oscillator (DCO) Mode

In DCO mode, a frequency control word (FCW) is passed directly from an external processor or FPGA to the DPLL with a step size of 1.11×10^{-10} ppm and a full range of +244.20ppm to -244.08 ppm of the nominal DCO frequency. A positive value will increase the output frequency and a negative one will decrease the output frequency. The formula for the calculation of the FCW from the fractional frequency offset (FFO) is as follows:

$$\text{FCW} = \left(1 - \frac{1}{\left(1 + \frac{\text{FFO}}{10^6} \right)} \right) \times 2^{53}$$

Where,

FFO = Fractional Frequency Offset, in ppm

FCW = Frequency Control Word (Positive or Negative Integer)

4.15.2.3 Numerically Controlled Oscillator (NCO) Mode

In NCO mode, each FOD in open-loop, except for FOD_0 in Jitter Attenuator mode, can adjust its output clock frequency with a step size of $(1/2^{43})/N$ where N is the nominal fractional output divide value, and is based on incrementing the numerator where the denominator of that fraction is fixed at 2^{43} . This frequency change at the output clock is gradual without glitches. The device can be in either Clock Generator mode or in Jitter Attenuator mode.

4.16 Clock Outputs

The RC32112A supports up to 12 differential or 24 single-ended clock outputs or any combination of differential and single-ended clock outputs. Every differential clock output can be programmed as two single-ended clock outputs.

4.16.1 Output Buffer in Single-Ended Mode

When used as a single-ended output buffer, two copies of the same output clock are created with LVCMOS output levels. Each clock will have the same frequency, phase, voltage, and current characteristics. The only exception is that the user can program the clock from the nQx output pad to be inverted in phase relative to the one coming from the Qx output pin. The non-inverted setting can result in greater noise on these outputs and increased coupling to other output clocks in the device, so it should be used with caution.

In this mode of operation, the output buffer supports 1.8V, 2.5V, or 3.3V V_{DDO_Qx} voltages. An output swing of 1.2V or 1.5V is supported from the V_{DDO_Qx} voltage of 1.8V. For each output voltage, there are four impedance options that can be selected from.

4.16.2 Output Buffer in Differential Mode

When used as a differential output buffer, the user can control the output voltage swing (V_{OVS}) and common mode voltage (V_{CMR}) of the buffer. Which V_{OVS} and V_{SWING} settings can be used with a particular V_{DDO_Qx} voltage are listed in [Table 25](#). Note that V_{DDO_Qx} options of 1.5V or 1.2V cannot be used in differential mode.

Table 25. Configurable Output Mode Options

| V_{DDO_Qx} | V_{OVS} Options Supported | V_{CMR} Options Supported |
|---------------|-----------------------------|--|
| 3.3V | 410mV | 0.9V, 1.1V, 1.3V, 1.5V, 1.7V, 1.9V, 2.1V, 2.3V |
| | 600mV | 0.9V, 1.1V, 1.3V, 1.5V, 1.7V, 1.9V, 2.1V, 2.3V |
| | 750mV | 0.9V, 1.1V, 1.3V, 1.5V, 1.7V, 1.9V, 2.1V |
| | 900mV | 0.9V, 1.1V, 1.3V, 1.5V, 1.7V, 1.9V |
| 2.5V | 410mV | 0.9V, 1.1V, 1.3V, 1.5V, 1.7V |
| | 600mV | 0.9V, 1.1V, 1.3V, 1.5V, 1.7V |
| | 750mV | 0.9V, 1.1V, 1.3V, 1.5V |
| | 900mV | 0.9V, 1.1V, 1.3V |
| 1.8V | 410mV | 0.9V, 1.1V, 1.3V |
| | 600mV | 0.9V, 1.1V, 1.3V |
| | 750mV | 0.9V, 1.1V, 1.3V |
| | 900mV | 0.9V, 1.1V |

4.16.3 Output Banks

The RC32112A maps the internal and external frequency sources to output banks, that can be programmed in the register map, according to [Table 26](#). There are up to 12 clock outputs that can be derived from each of the six FODs.

Table 26. Output Bank Assignment

| Output Pins | FODs that can Drive this Stage |
|---|-----------------------------------|
| Q0 / nQ0 | FOD_0 |
| Q1 / nQ1 | FOD_0, FOD_1 |
| Q2 / nQ2 | FOD_1, FOD_5 |
| Q8 / nQ8 | FOD_5 |
| Q3 / nQ3, Q4 / nQ4, Q5 / nQ5, Q9 / nQ9, Q10 / nQ10 | FOD_0, FOD_1, FOD_2, FOD_3, FOD_5 |
| Q6 / nQ6 | FOD_2, FOD_3, FOD_7 |

Table 26. Output Bank Assignment (Cont.)

| Output Pins | FODs that can Drive this Stage |
|-------------|--------------------------------|
| Q7 / nQ7 | FOD_3, FOD_7 |
| Q11 / nQ11 | FOD_7 |

4.17 General Purpose Input/Outputs (GPIOs)

The GPIO signals provide a flexible method for managing the control and status of the part via pins without providing dedicated pins for each possible function that may be wasted in a lot of applications. The GPIOs are fully configurable so that any GPIO can perform any function on any target logic block.

4.17.1 GPIO Modes

Each GPIO pins can be individually configured to operate in one of the following modes. Note that these modes are effective only when the RC32112A has completed its reset sequence. During the reset sequence one or more of these pins may have different functions as outlined in [Use of GPIO Pins at Reset](#):

- General Purpose Input – In this mode of operation, the GPIO pin will act as an input whose logic level will be monitored and reflected in an internal register that may be read over the serial port. This is the default mode if no other option is programmed in OTP or EEPROM.
- General Purpose Output – In this mode of operation, the GPIO pin will act as an output that is driven to the logic level specified in an internal register. That register can be written over the serial port.
- Alarm output – In this mode of operation, the GPIO pin will act as a single-purpose alarm or Alert (aggregated alarm) output. For information on when an alarm output will be asserted or released and alarm sources, see [Alarm Output Operation](#). Note that each GPIO can be independently configured and so if multiple GPIOs are configured the same way, they will all have the same output values.
 - Loss-of-Signal status – In this mode of operation, the GPIO pin will act as an active-high Loss-of-Signal output. When the GPIO output is asserted, that indicates the selected input reference monitor is indicating an alarm condition. The related reference monitor and the associated GPIO pin are configured via registers. Configuration of the reference monitor will determine what constitutes an alarm. Note that the GPIO output reflects the actual state of the alarm signal from the selected reference monitor. This is not a latched or “sticky” signal. Note that this is different than the other alarm sources below.
 - Loss-of-Lock status – In this mode of operation, the GPIO pin will act as an active-high Loss-of-Lock output. When the GPIO output is asserted, that indicates the System APLL or DPLL has lost lock. The related PLL channel and associated GPIO pin are configured via registers. Note that the GPIO output reflects the “sticky” state of the alarm signal from the selected PLL channel. This is a latched or sticky signal and so must be cleared by register access to the sticky bit clear register to remove the alarm signal.
 - Holdover status – In this mode of operation, the GPIO pin act as an active-high Holdover status. When the GPIO output is asserted, that indicates the DPLL for the selected PLL channel has lost all its input references and is in a holdover state. The related PLL channel and associated GPIO pin are configured via registers. Note that the GPIO output reflects the “sticky” state of the alarm signal from the selected PLL channel. This is a latched or sticky signal and so must be cleared by register access to the sticky bit clear register to remove the alarm signal.
 - Alert (aggregated alarm) status – In this mode of operation, the GPIO will act as the logical OR of all alarm indicators that are enabled to drive this output. Only “sticky” bits are available to drive the GPIO in this mode. This output will be asserted if any of the sticky bits are asserted and enabled to cause the Alert (aggregated alarm). To clear this output, all contributing sticky bits must be individually cleared. This output will be active-high to indicate one or more alarms are asserted.
- Output Disable control – In this mode of operation, the GPIO pin will act as a control input. When the GPIO input is high, the selected output clock(s) will be disabled, then placed in high-impedance state. When the GPIO pin is low, the selected output clock(s) will be enabled and drive their outputs as configured. Selection of which output(s) are controlled by which GPIO(s) is configured via registers over the serial port or by OTP or EEPROM

at reset. Each GPIO can be configured to control any or all outputs (or none). So all combinations can be set up from a single GPIO controlling all outputs, to all outputs responding to individual GPIO signals and any grouping in between.

- Single-ended Input Clock – In this mode of operation a single-ended input clock can be applied to certain GPIOs that map to specific input stages. This can be used if extra single-ended inputs are needed due to all input reference clock pins are taken-up by differential input references. This mode cannot be used if an input stage already has two single-ended input references from the CLKx/nCLKx input pins.
- Manual Clock Selection control – In this mode of operation, the GPIO pin acts as an input that will manually select between one of two inputs for a specific DPLL channel. The specific input references and the PLL channel must be pre-configured via registers. Assertion of the GPIO will select the higher priority input and de-assertion will select the lower priority input.
- DCO Increment – In this mode of operation, the GPIO pin will act as an increment command input pin for a specific channel configured as a DCO. The rising edge of the GPIO pin will cause an increment function on the indicated DCO. The amount of the increment and the related DCO to increment must be previously configured via registers.
- DCO Decrement – In this mode of operation, the GPIO pin will act as a decrement command input pin for a specific channel configured as a DCO. The rising edge of the GPIO pin will cause a decrement function on the indicated DCO. The amount of the decrement and the related DCO to decrement must be previously configured via registers.

4.17.2 GPIO Pin Configuration

The GPIO pins are all powered off a single voltage supply that only supports 1.8V operation. An internal register must be set to indicate 1.8V. This setting is a global one for all GPIOs.

In addition, each GPIO can be enabled or disabled under register control. If enabled and configured in an operating mode that makes it an output, the user can choose if the GPIO output will behave as an open-drain output or a CMOS output. The open-drain output drives low, but is pulled high by a pull-up resistor. There is a very weak pull-up internal to the RC32112A, but an external pull-up is strongly recommended. In CMOS mode, the output voltage will be driven actively both high and low as needed. Register control can also enable a pull-up (default) or pull-down.

4.17.3 Alarm Output Operation

There are many internal status and alarm conditions within the RC32112A that can be monitored over the serial port by polling registers. Several of these can be directed to GPIO pins. In addition there is the ability to designate one of the GPIOs as an Alert (aggregated alarm) output signal called an Alert output.

The RC32112A provides both a “live” and a “sticky” status for each potential alarm condition. A live bit shows the status of that alarm signal at the moment it is read over the serial port. A sticky bit will assert when an alarm condition changes state and will remain asserted until the user clears it by writing to the appropriate clear bit over the serial port. When a GPIO is configured to show the status of a specific alarm, it will show the live or sticky status of that alarm, depending on the specific alarm, where a high output on the GPIO indicates the alarm is present.

The Alert (aggregated alarm) output logic only uses the sticky status bit for alarms. This ensures when a software routine reads the RC32112A there will be an indication of what caused the alarm in the first place. Note that there can be multiple sticky bits asserted. [Table 27](#) shows the possible alarm conditions within the RC32112A. Note that the reference monitor, the DPLL, and the System DPLL blocks can generate the indicated alarms.

Table 27. Alarm Indications

| Logic Bloc | Specific Alarm | Conditions for Live Alarm ^[1] to Assert | Conditions for Live Alarm ^[1] to Negate ^[2] |
|------------------------|---------------------------------|---|---|
| Reference Monitoring | Frequency Offset Limit Exceeded | When reference monitor indicates reference frequency above the rejection range. | When reference monitor indicated reference frequency within acceptance range. |
| | Loss-of-Signal | When reference monitor indicates reference period above the threshold. | When reference monitor indicates reference period below the threshold. |
| | Activity Alarm | When reference monitor indicates reference frequency above the threshold. <i>Note:</i> Activity alarm is not as accurate as frequency offset limit monitor but is quicker to report. | When reference monitor indicates reference frequency below the threshold. <i>Note:</i> Activity alarm is not as accurate as frequency offset limit monitor but is quicker to report. |
| DPLL ^{[3][4]} | Holdover | DPLL has entered / is in the Holdover state | DPLL no longer in Holdover state |
| | Locked | DPLL has entered / is in the Locked state and System APLL is in the Locked state | DPLL and/or System APLL no longer in the Locked state |

1. “Sticky” alarm bits are set whenever the associated live alarm changes state. So there will be a new sticky alarm on both assertion and negation of the appropriate live alarm indication.
2. Only the “live” status will negate by itself. The sticky needs to be explicitly cleared by the user.
3. For the Digital PLL, sticky alarms are raised when the state machine transitions into specific states and live status indicates that the Digital PLL is currently in a specific state. The user can read the current state of the Digital PLL state machine from status registers over the serial port.
4. This includes the System DPLL, as well as all Digital PLL.

For each alarm type in each of the logic blocks that can generate them, there is a “live” status, a “sticky” status, a “sticky” clear control and a series of control bits that indicate what effects the alarm will have. When the live status asserts, the sticky status will also assert. If configured via registers, that alarm can generate an external signal via GPIO. That signal can be an individual alarm output or an Alert (aggregated alarm). When external software responds, it is expected to read the sticky status bits to determine the source(s) of the alarm and any other status information it may need to take appropriate action. The sticky clear control can be used to clear any or all of the bits that contributed to the alarm output being asserted.

In addition to the above controls and status, each potential alarming logic block has its own controls and status. Each of the reference monitors has a sticky status bit, a sticky clear bit, and various control bits. The DPLL and system DPLL each have a sticky status bit, a sticky clear bit, control bits, and a PLL state status field. These functions behave as described in the previous paragraph. Note that both the individual alarm sticky status and the logic block sticky status must be cleared to fully remove the source of the alarm output. Individual sticky alarms should be cleared first so that all individual alarms associated with a logic block will not cause a re-assertion of the block sticky alarm.

There are also several configuration bits that act on the alarm output logic as a whole. There is a global alarm enable control that will enable or disable all alarm sources. This can be used during alarm service routines to prevent new alarms while that handler is executing in external software. There is also the ability to designate a GPIO as an Alert (aggregated alarm) output and determine which individual alarms will be able to drive it.

4.18 Temperature Sensor

The RC32112A includes a temperature sensor. The accuracy of the sensor is $\pm 2^{\circ}\text{C}$. The temperature can be read in degrees Celsius from registers. The reading is updated once every 10 seconds.

4.19 Device Initial Configuration

During its reset sequence, the RC32112A will load its initial configuration, enable internal regulators, establish and enable internal clocks, perform initial calibration of the Analog PLL, and lock it to the reference on the OSCI / OSCO pins. Depending on the initial configuration it may also bring-up Digital PLLs, lock to input references including any OCXO/TCXOs and generate output clocks.

There are four methods that can be used to establish the initial configuration during the reset sequence:

- State of certain GPIO pins (see Table 28) at the rising edge of the nMR signal
- Configuration previously stored in One-Time Programmable memory
- Configuration stored in an external I²C EEPROM
- Default values for internal registers

Each of these methods is discussed in the following sections and then integrated into the reset sequence.

4.19.1 Use of GPIO Pins at Reset

Several of the device GPIO pins are sampled at the rising edge of the nMR (master reset) signal and are used in setting the initial configuration. Table 28 shows which pins are used to control what aspects of the initial configuration. All of these register settings can be overwritten later via serial port accesses.

Table 28. GPIO Pin Usage at Start-Up

| GPIO Number | Function | Internal Pull-up or Pull-down |
|---------------------------------------|--|-------------------------------|
| 9 | 0 = Device uses SPI protocol 1 = Device uses I ² C protocol | Pull-up |
| 4 pins user selectable ^[1] | Identifies which stored configuration in OTP to use for initial configuration (has no effect with "-000" unprogrammed devices). | Pull-up |
| 1 pin user selectable ^[1] | Disables EEPROM accesses during start-up sequence By default, no GPIO is used for this purpose, so the device will attempt to find an external EEPROM to check for additional start-up information by default. | Pull-up |
| 1 pin user selectable ^[1] | Provides pin control for I ² C slave serial port (for serial port selected by GPIO[9] as I ² C) default base address bit A2. Has no effect on serial port selected as SPI. By default no GPIO is used for this purpose, so the default I ² C slave port base address will have a 0 for bit A2. | Pull-up |

1. Selection of this mode for a GPIO is performed using the Device Information block in the OTP memory, which is programmed by Renesas at the factory for dash codes that are non-zero. "-000" dash code devices are considered unprogrammed and so will have the default behavior indicated above.

Any of the available GPIOs can be used as follows:

- I²C base address bit A2

This is for the serial port, whichever is selected as I²C during the start-up sequence using GPIO[9]. If no GPIOs are configured in this mode, bit A2 of the slave serial port base address will be zero. The value of the I²C base address and the serial port configuration can be overwritten by SCSR configuration data or serial port accesses later in the start-up sequence. If more than one GPIO is programmed with this functionality, only the one with the highest index will be used.

- EEPROM Access Disable control

A high input value on a GPIO programmed with this function prevents device from attempting to read device update information or SCSR configuration data from an external I²C EEPROM. This will speed up device reset time but prevents access to updated information that may be stored in an EEPROM. If no GPIOs are configured in this mode, then the device will attempt to locate an external EEPROM at the appropriate point in the start-up

sequence. If multiple GPIOs are configured to perform this function, then any one of them being active will disable EEPROM accesses, so it is recommended that no more than one GPIO be programmed for this function.

- Default Configuration Select control

If no GPIOs are selected then GPIO[3:0] will be assumed and the value on those pins at the rising edge of the nMR signal will be used to select which of the SCSR configurations in OTP memory is to be used. Note that since a GPIO is pulled up by default, unless these pins are pulled or driven low during the reset period, this will select SCSR Configuration 15.

If one or more GPIOs are selected for this function, then the value on those pins at the rising edge of nMR will be used to select the SCSR configuration to be loaded. The Device Information block of the OTP can be configured to select any of up to four GPIO pins to be used for this purpose if the default GPIOs are not convenient. The GPIOs chosen do not have to be sequential, but whichever ones are selected, the one with the lowest index number will be the LSB and so on in order of the index until the GPIO with the highest index is the MSB. No GPIO that appears elsewhere in this table should be used for this purpose.

If less than four GPIO pins are selected, then the selected GPIOs will be used as the least-significant bits of a 4-bit selection value, with the upper bits set to zero. If more than four GPIOs are programmed for this function, then the GPIOs will form a larger bit-length word for selection of internal configuration.

4.19.2 Default Values for Registers

All registers are defined so that the default state (without any configuration data from OTP or EEPROM being loaded) will cause the device to power up with none of the outputs enabled and all GPIO signals in General-Purpose Input mode. Users can then program any desired configuration data over the serial port once the reset sequence has completed.

4.20 One-Time Programmable (OTP) Memory

The RC32112A contains a 32KB One-Time Programmable (OTP) memory block that is customer programmable. The term “one-time programmable” refers to individual blocks within the memory structure. Different blocks can be programmed at different times, but each block can only be programmed once. The data structure within the OTP is designed to facilitate multiple updates and multiple configurations being stored, up to the limit of the physical memory space.

Access to OTP memory is via serial port through registers that communicate with an internal OTP controller state machine. The state machine protocol is handled using Timing Commander GUI software, which is the recommended access mechanism. For customers who want to program OTP using another method, such as in their own production processes, should contact [Renesas](#) for details on this state machine interface. Note that OTP programming is considered an “offline” function and should not be performed while the device is in an operational system.

After reset of the RC32112A, all internal registers are reset to their default values, then OTP contents are loaded into the device’s internal registers. A Device Information block programmed by Renesas at Final Test will always be loaded. This provides information that is specific to the device, including product ID codes and revision information. In addition there are zero or more device configurations stored in the OTP by customer programming or by Renesas at the factory if a special dash-code part number is requested. Certain GPIO pins are sampled at the rising edge of the external nMR input signal. The state of those pins at that time will be used by the RC32112A to determine which of up to 16 configurations stored in the OTP to load into the device registers. For information on how to select a configuration, see [Use of GPIO Pins at Reset](#).

Storage of configuration data in OTP does not require having a value stored for every register in the device. Register default values are defined to ensure that most functions will be disabled or otherwise made as neutral as possible. This allows only features that are being used in any particular configuration (and their associated trigger registers as defined in the 8A3xxxx Family Programming Guide) to need to be stored in OTP for that configuration. The intent of this is to minimize the size a configuration takes in OTP to allow more configurations to be stored

there. For this reason, the exact number of configurations store-able in OTP can't be predetermined. There will be a minimum of 2 configurations and a maximum of 16 configuration capacity in the OTP.

Part numbers with -000 as the dash code number are considered 'unprogrammed' parts, but will come with at least a Device Information block pre-programmed with Renesas-proprietary information including parameters needed to successfully boot the device to the point where it can read its configuration data. One Device Update block may also be programmed if determined to be appropriate by Renesas.

Custom user configurations indicated with non-zero dash code part numbers will in addition have one or more SCSR Configuration sections pre-programmed as indicated in the datasheet addendum document for that particular dash code part number.

Note that a programmed configuration, Device Information block or Device Update block may be invalidated via the OTP programming interface and if sufficient OTP space remains a new one added to replace it. Note that this does not erase or remove the original data and the space it consumes. It just marks it to be ignored by the device. This allows for a limited ability to update a device in the field either from a device functional update or configuration data perspective. This is a purely software-driven process handled over the serial port. If this type of in-field upgrade / change is desired, please contact [Renesas](#) Technical Support. Note that the ability to perform this type of in-field update is highly dependent on the size of the change versus the remaining space in OTP, so will not be possible in all cases.

4.20.1 Configuration Data in OTP

Users can program multiple configurations into the internal One-Time Programmable memory. The Timing Commander GUI Software can perform this function. For sample code if this needs to be performed in another way by the end-user, please contact [Renesas](#). By using the GPIO pins at start-up as outlined in the [Use of GPIO Pins at Reset](#), one of those configurations can be chosen for use as the initial values in the device registers after reset. Register values can be changed at any time over the serial port, but any such changes are not stored in OTP and will be lost on reset or power-down.

The OTP is organized so that only configuration data that changes from the register default values needs to be stored. This saves OTP space and allows the potential for more configurations to be stored in the OTP.

If the indicated configuration in OTP has a checksum error, it will not be loaded and registers will be left at their default values.

4.20.2 Configuration Data in External I²C EEPROM

As a final option, the initial configuration can be read from one or more external I²C EEPROMs. The Timing Commander GUI Software can generate the necessary EEPROM load information as an Intel HEX file for this purpose. The RC32112A will search each EEPROM for a valid configuration data block (valid header and checksum). The first valid block found will be loaded into internal registers after checksum validation. The search will terminate after the first valid block is found and loaded. This means that only a single valid configuration block can be stored via the EEPROM method.

The RC32112A will look for EEPROMs at I²C base addresses of 1010xxx (binary), and search each EEPROM from the lowest address to the highest. When the device searches for an EEPROM configuration, it will check for a valid block at address offsets 0x0000 and 0xF000 within an EEPROM. If using this configuration method, see the warning in [Step 5 – Search for Configuration in External EEPROM](#).

4.21 Reset Sequence

Figure 15 shows the relationship between the master reset signal (nMR) and the supply voltages for the RC32112A. There are no power sequencing requirements between the power rails, so V_{DD} in the diagram represents any of the supply voltages. To ensure there is no anomalous behavior from the device as it powers up, it is recommended that the nMR signal be asserted (low) before any voltage supply reaches the minimum voltage shown in the figure. nMR should remain asserted until a short hold time ($t_{HOLD} \sim 10\text{nsec}$) after all supply voltages reach the operating window of 95% of nominal voltage. nMR must be asserted or the device will not function correctly after power-up.

One additional consideration is that once minimum voltage is reached on all voltage supplies, internal regulators and voltage references will take up to $3\mu\text{sec}$ to reach stability. If the time t_{RAMP} shown in the figure is less than the voltage regulator startup time of $3\mu\text{sec}$, then release of nMR should be delayed.

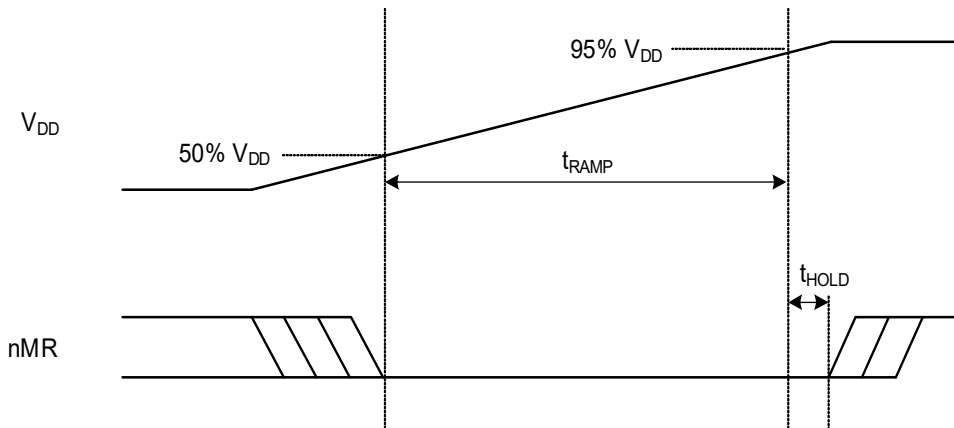

Figure 15. Power-Up Reset Sequencing

In cases where the device is not powering up and just being reset, a low pulse on nMR of 20ns is sufficient to reset the device.

The reset sequence discussed below will begin from the rising (negating) edge of the nMR (master reset) signal.

4.21.1 Step 0 – Reset Sequence Starting Condition

When the power rails reach nominal values and the nMR signal has been asserted, the RC32112A will be in the following state:

- All Qx / nQx outputs will be in a high-impedance state.
- All GPIO pins will be set to General-Purpose Inputs, so none will be driving the output.
- The serial port protocols are not set at this point in the reset sequence, so the ports will not respond.
- OTP will be checked for any device patch information and if any is found, it will be loaded and the device reinitialized.
- Device Information block loaded from internal OTP to configure what GPIOs will be used for what start-up functions in Step 1.

4.21.2 Step 1 – Negation of nMR (Rising Edge)

At the rising edge of the nMR signal, the state on the GPIO pins at that time is latched. After a short hold time, the GPIOs can release their reset levels and assume their normal operation modes. The latched values will be used in later stages of the reset sequence.

4.21.3 Step 2 – Internally Set Default Conditions

An internal image of all the device registers will be created in internal RAM with all registers set to their default values. This will not result in any changes to the GPIO or output clock signals from their Step 0 condition.

Based on the serial port protocol selection made via the GPIO pin in Step 1, serial port configuration will be completed as indicated by the GPIO input pin. If SPI mode is selected by the GPIO, the register default values will configure it to use 4-wire SPI mode.

4.21.4 Step 3 – Scan for Device Updates in EEPROM

Unless a GPIO is configured to control this in Step 0 and in Step 1 is sampled in the state requesting no EEPROM read, this step will be performed by the RC32112A. The RC32112A will use the I²C Master port (if available) to check for device functional update information. If such information is found, it will be loaded, the device functionality updated and then the part will reinitialize to Step 0.

4.21.5 Step 4 – Read Configuration from OTP

Using the GPIO values latched in Step 1, the device will search the internal One-Time Programmable memory for the indicated configuration number. If no such configuration is found or the configuration has an invalid checksum, the device will skip to Step 6. Any errors in this process will be reported. If loading from OTP was successful, which configuration number was loaded will be reported.

If the requested configuration is found and is valid, the device will load the registers indicated in the configuration data with the stored data values in the internal register image. Any register not included in the configuration data set will remain at its default value in the register image.

Note: Many register modules have explicitly defined trigger registers that when written will cause the other register settings in that module to take effect. Users must ensure that the configuration in OTP will cause a write to all applicable trigger registers, even if that register's contents would be all zero. Multi-byte register fields also require all bytes of the field to be written to ensuring triggering. For information on which trigger registers are associated with which other registers, see the *8A3xxxx Family Programming Guide*.

The contents of several registers will be used to guide the remainder of the reset sequence.

- If the APLL feedback divider value was programmed in this step, perform APLL calibration in parallel with remaining reset activities.
- Re-configure serial ports to use I²C or SPI protocols as indicated (for information, see the [I²C Slave Operation](#) or [SPI Operation](#)).

4.21.6 Step 5 – Search for Configuration in External EEPROM

Unless a GPIO is configured to control this in Step 0 and in Step 1 is sampled in the state requesting no EEPROM read, this step will be performed by the RC32112A.

The device will use its I²C Master Port to attempt to access an external I²C EEPROM at base address 1010000 (binary) at an I²C frequency of 1MHz. If there is no response, this will be repeated at base address 1010001 (binary) at 1MHz. This will repeat up to address 1010111 (binary) at 1MHz. If there still are no responses, the search will be repeated at 400kHz and then again at 100kHz. If no response is received after the complete sequence, the device will proceed to Step 6. Any errors in the process will be reported in status registers.

If at any point in the above search sequence a response is received from an EEPROM, the device will read data from the EEPROM at address offsets 0x0000 and 0xF000 in the EEPROM. If a valid configuration data block is found, it will be read, its checksum validated and if that passes, loaded into internal the internal register image similarly to OTP configuration data described in Step 4. If the data found is not of the correct format or the data block fails a checksum comparison, it will be ignored. The search will continue through the EEPROM and on to the next EEPROM address until the whole range has been searched or a valid configuration block has been found and applied to the internal register image, then the sequence will proceed to Step 6.

Warning: Since OTP and EEPROM configuration data rarely consists of a full register image, reading of configuration data from OTP and then from one or more configuration blocks stored in EEPROM may result in internal registers being loaded with conflicting settings drawn partially from each of the configuration data sets being loaded. It is strongly recommended that a configuration block placed in EEPROM only be used when no valid configuration is being pointed to in OTP by GPIO signals (or there is no valid configuration in OTP at all).

If multiple configurations are to be used then the user must ensure all registers are set to the desired values by the final configuration block to be loaded.

4.21.7 Step 6 – Complete Configuration

The RC32112A will complete the reset and initial configuration process at this point and begin normal operations. Completion steps include:

1. Calibrate the System APLL and lock it to the reference clock on the OSC1 input.
2. Perform a temperature sensor cycle to establish an initial value in internal registers.
3. Enable serial port operation as configured.
4. Apply configuration settings from the internal register image to the actual registers and enable output clocks and GPIOs as configured.
5. Begin operation on input reference monitors and PLL state machine alarms / status.
6. Enable alarm operation as configured.

Note that there are several scenarios where the reset sequence will reach this point without retrieving any configuration data and with all registers in the default state. This may be intentional for users who want to configure only via the serial port or the result of a problem in the loading of a configuration. Users can read appropriate status bits to determine what failures, if any, occurred during the reset sequence.

4.22 Clock Gating and Logic Power-Down Control

The RC32112A can disable the clocks to many logic blocks inside the device. It also can turn off internal power regulators, disabling individual power domains within the part. Because of the potentially complex interactions of the logic blocks within the device, logic within the part will handle the decision-making of what will be powered off versus clock-gated versus fully operational at any time. By default, the device will configure itself with functions in the lowest power-consuming state consistent with powering up the part and reading a user configuration. User configurations, whether stored in internal OTP, external EEPROM, or manually adjusted over the serial port, should make use of register bits to only turn on functions that are needed. Also if a function is no longer needed, register bits should be used to indicate it is no longer required. Internal logic will reduce its power-consumption state in reaction to these indicators to the greatest extent possible.

4.23 Serial Port Functions

The RC32112A supports one serial port. The signals on the port share the functions of an I²C Master port used for loading configuration data at reset and a configurable slave I²C or SPI port that can be used at any time after the reset sequence is complete to monitor and/or configure the device. Note that the I²C master port can only be used when the slave port is configured in I²C mode. Since I²C master operation only occurs immediately after reset, while configuration or other data is being loaded from an external I²C serial EEPROM, I²C mode for the serial port can be selected via GPIOs as indicated in [Use of GPIO Pins at Reset](#).

The operation of the serial port when in I²C master operation (during self-configuration only) is described in [I²C Master](#). The SCL and SDIO pins are used for this purpose. For information on the operation of the master I²C and slave I²C or SPI ports, see the appropriate section below.

A slave serial port can be reconfigured at any time by accessing the appropriate registers within a single burst write. This includes configuration options with each protocol or switching between protocols (I²C to SPI, or vice versa). However, it is recommended that the full operating mode configuration, including page sizes for registers, for a serial port be set in the initial configuration data read from OTP or external EEPROM (for information, see [Device Initial Configuration](#)).

Note on Signal Naming in the Remainder of the Serial Port Sections

The pin names indicated in [Pin Descriptions](#) are intended to indicate the function of that signal when used in SPI mode and also the function when in I²C mode. In the remainder of the Serial Port Functions descriptions, the SPI descriptions will refer to the signals by their function in the selected mode, as shown in [Table 29](#).

Table 29. Serial Port Pin to Function Mapping

| SPI Mode Signal Name | Function | I ² C Mode Signal Name | Function | Package Pin Name |
|----------------------|---|-----------------------------------|--------------------------------------|------------------|
| SCLK | SPI Clock Input | SCLK | I ² C Clock Input | SCLK |
| CS | SPI Chip Select (active low) | A0 | I ² C Slave Address Bit 0 | CS_A0 |
| SDI | SPI Data Input (unused in 3-wire mode) | A1 | I ² C Slave Address Bit 1 | SDI_A1 |
| SDIO | SPI Data Out (4-wire mode) SPI Data In/Out (3-wire mode) | SDA | I ² C Data In/Out | SDIO |

4.23.1 Addressing Registers within the RC32112A

The address space that is externally accessible within the RC32112A is 64KB in size and so needs 16 bits of address offset information to be provided during slave serial port accesses. Of that 64KB, only the upper 32KB contains user-accessible registers.

The user can choose to operate the serial port providing the full offset address within each burst, or to operate in a paged mode where part of the address offset is provided in each transaction and part comes from an internal page register in each serial port. [Figure 16](#) shows how page register and offset bytes from each serial transaction interact to address a register within the RC32112A.

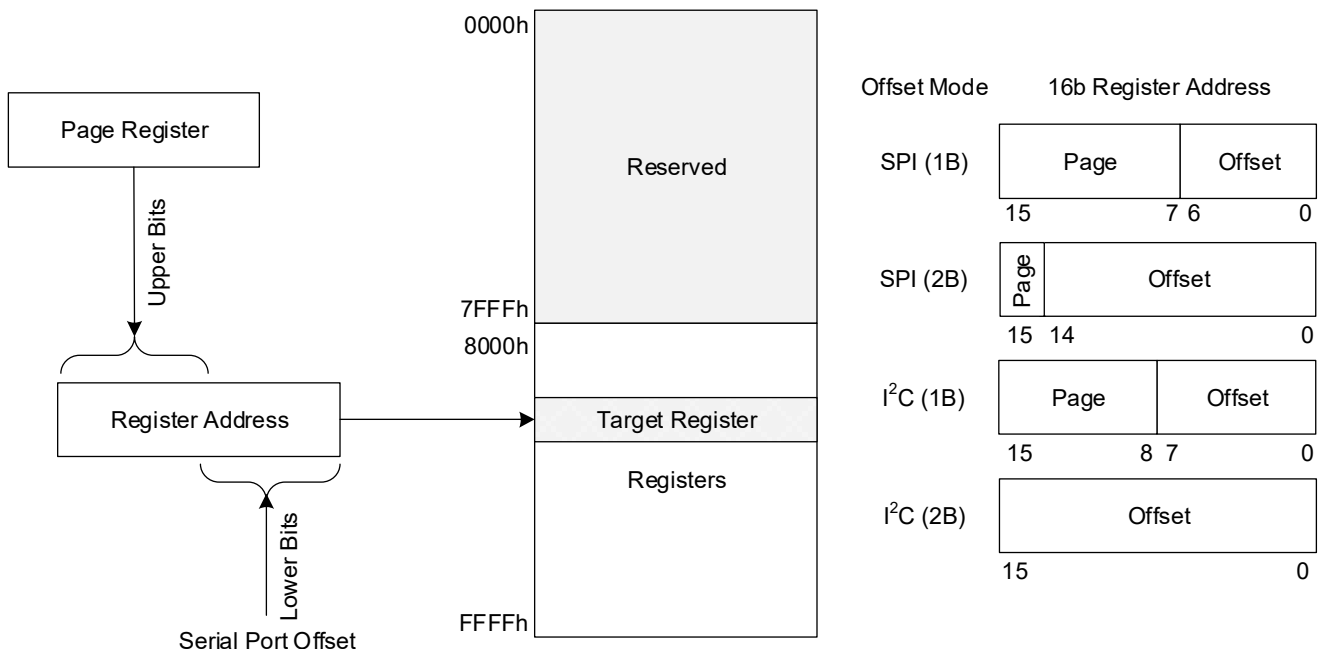
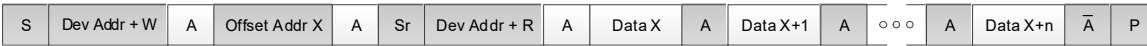

Figure 16. Register Addressing Modes via Serial Port

4.23.2 I²C Slave Operation

The I²C slave protocol of the RC32112A complies with the I²C specification version UM10204 Rev.6 – 4 April 2014. [Figure 17](#) shows the sequence of states on the I²C SDA signal for the supported modes of operation.

Sequential 8-bit Read



Sequential 8-bit Write



Sequential 16-bit Read



Sequential 16-bit Write



- From master to slave
- From slave to master
- S = Start
- Sr = Repeated start
- A = Acknowledge
- \bar{A} = Non-acknowledge
- P = Stop

Figure 17. I²C Slave Sequencing

The Dev Addr shown in the figure represents the base address of the RC32112A. This 7-bit value can be set in an internal register which can have a user-defined value loaded at reset from internal OTP memory or an external EEPROM. The default value if those methods are not used is 1011000b. Note that the levels on the A0 and A1 signals can be used to control Bit 0 and Bit 1, respectively, of this address. There is also an option as defined in [Use of GPIO Pins at Reset](#) to designate the reset state of a GPIO pin to set the default value of the A2 bit of the I²C slave port base address. In I²C operation these inputs are expected to remain static. They have different functions when the part is in SPI mode. The resulting base address is the I²C bus address that this device will respond to.

When I²C operation is selected for a slave serial port, the selection of 1-byte (1B) or 2-byte (2B) offset addressing must also be configured. These offsets are used in conjunction with the page register for each serial port to access registers internal to the device. Because the I²C protocol already includes a read/write bit with the Dev Addr, all bits of the 1B or 2B offset field can be used to address internal registers.

- In 1B mode, the lower 8-bits of the register offset address come from the Offset Addr byte and the upper 8-bits come from the page register.

The page register can be accessed at any time using an offset byte value of FCh. This 4-byte register must be written in a single burst write transaction.

- In 2B mode, the full 16-bit register address can be obtained from the Offset Addr bytes, so the page register only needs to be set up once after reset via a 4-byte burst access at offset FFFCh.

Note: I²C burst mode operation is required to ensure data integrity of multi-byte registers. When accessing a multi-byte register, all data bytes must be written or read in a single I²C burst access. Bursts can be of greater length if desired, but must not extend beyond the end of the register page (Offset Addr FFh in 1B mode, no limit in 2B mode). An internal address pointer is incremented automatically as each data byte is written or read.

4.23.2.1 I²C 1-byte (1B) Addressing Examples

The RC32112A I²C 7-bit I²C address is 0x5B with LSB = R/W

Example write “0x50” to register 0xCBE4:

```
B6* FC 00 CB 10 20#Set Page Register, *I2C Address is left-shifted one bit.
B6 E4 50           #Write data 5B to CB E4
```

Example read from register 0xC024:

```
B6* FC 00 C0 10 20#Set Page Register, *I2C Address is left-shifted one bit.
B6 24*           #Set I2C pointer to 0xC024, *I2C instruction should use “No
Stop”
B7 <read back data>#Send address with Read bit set.
```

4.23.2.2 I²C 2-byte (2B) Addressing

The RC32112A I²C 7-bit I²C address is 0x5B with LSB = R/W

Example write “50” to register 0xCBE4:

```
B6* FF FD 00 10 20#Set Page Register, *I2C Address is left-shifted one bit.
B6 CB E4 50           #Write data to CB E4
```

Example read from register 0xC024:

```
B6* FF FD 00 10 20#Set Page Register (*I2C Address is left-shifted one bit.)
B6 C0 24*           #Set I2C pointer to 0xC024, *I2C instruction should use “No
Stop”
B7 <read back data>#Send address with Read bit set.
```

4.23.3 I²C Master

The RC32112A can load its register configuration from an external I²C EEPROM during its reset sequence, but only if the serial port is configured in I²C mode. For information on what accesses occur under what conditions, see [Reset Sequence](#).

As needed during the reset sequence, the RC32112A will arbitrate for the I²C bus and attempt to access an external I²C EEPROM using the access sequence shown in [Figure 18](#). The I²C master protocol of the RC32112A complies with the I²C specification version UM10204 Rev.6 – 4 April 2014. As can be seen in the figure, the I²C master port can be configured to support I²C EEPROMs with either 1-byte or 2-byte offset addressing. The I²C master logic will negotiate with any EEPROMs found to use the highest speed of 1MHz, 400kHz, or 100kHz.

Sequential Read (1-byte Offset Address)



Sequential Read (2-byte Offset Address)

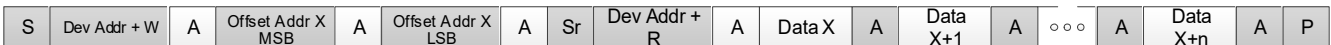

- From master to slave
- From slave to master
- S = Start
- Sr = Repeated start
- A = Acknowledge
- Ā = Non-acknowledge
- P = Stop

Figure 18. I²C Master Sequencing

4.23.4 SPI Operation

The RC32112A supports SPI operation as a selectable protocol on the serial port. The port can be configured for either 3-wire or 4-wire operation. In 4-wire mode, there are separate data in (to the RC32112A) and data out (signals (SDI and SDIO respectively). In 3-wire mode, the SDIO signal is used as a single, bidirectional data signal. [Figure 19](#) shows the sequencing of address and data on the serial port in both 3-wire and 4-wire SPI mode. 4-wire SPI mode is the default. The R/W bit is high for Read Cycles and low for Write Cycles.



Figure 19. SPI Sequencing

A serial port can be configured for the following settings. These settings can come from register defaults or from an internal OTP or external EEPROM configuration loaded at reset:

- 1-byte (1B) or 2-byte (2B) offset addressing (see [Figure 16](#))
 - In 1B operation, the 16-bit register address is formed by using the 7 bits of address supplied in the SPI access and taking the upper 9 bits from the page register. The page register is accessed using an Offset Address of 7Ch with a 4-byte burst access.
 - In 2B operation, the 16-bit register address is formed by using the 15 bits of address supplied in the SPI access and taking the upper 1 bit from the page register. Note that this bit will always be 1 for register accesses, so the page register only needs to be set once in 2B operation. The page register can be accessed using a 3-byte burst access Offset Address of 7FFDh. It should be accessed in a single burst write transaction to set it.
- Data sampling on falling or rising edge of SCLK
- Output (read) data positioning relative to active SCLK edge
- 4-wire (SCLK, CS, SDIO, SDI) or 3-wire (SCLK, CS, SDIO) operation
- In 3-wire mode, SDIO is a bi-directional data pin.
- Output signal protocol compatibility / drive strength and termination voltage

Note: SPI burst mode operation is required to ensure data integrity of multi-byte registers. When accessing a multi-byte register, all data bytes must be written or read in a single SPI burst access. Bursts can be of greater

length if desired, but must not extend beyond the end of the register page. An internal address pointer is incremented automatically as each data byte is written or read.

4.23.4.1 SPI 1-byte (1B) Addressing Example

Example write to “50” to register 0xCBE4:

```
7C 80 CB 10 20    #Set Page register
64* 50            #*MSB is 0 for write transactions
```

Example read from 0xC024:

```
7C 00 C0 10 20    #Set Page register
A4* 00            #*MSB is set, so this is a read command
```

4.23.4.2 SPI 2-byte (2B) Addressing Example

Example write to “50” to register 0xCBE4

```
7F FD 80 10 20    #Set Page register
4B E4* 50         #*MSB is 0 for write transactions
```

Example read from 0xC024:

```
7F FD 80 10 20    #Set Page register
C0* 24 00         #*MSB is set, so this is a read command
```

4.23.5 JTAG Interface

The RC32112A provides a JTAG interface that can be used in non-operational situations with the device when nTEST control pin is held low. The JTAG interface is compliant with IEEE-1149.1 (2001) and supports the IDCODE, BYPASS, EXTEST, SAMPLE, PRELOAD, HIGHZ, and CLAMP instructions. For information on the value the IDCODE instruction will return for the RC32112A, see the *RC32112A Programming Guide Addendum*.

JTAG port signals share five pins with GPIO functions as outlined in [Table 30](#). Assertion of the nTEST input (active low) will place those pins in JTAG mode.

Table 30. JTAG Signal Mapping

| Function with nTEST Active (Low) | Function when nTEST Inactive (High) |
|----------------------------------|-------------------------------------|
| TCK | GPIO[0] |
| TMS | GPIO[1] |
| TDI | GPIO[2] |
| TDO | GPIO[3] |
| TRSTn | GPIO[4] |

5. Applications Information

5.1 Recommendations for Unused Input and Output Pins

5.1.1 Inputs

5.1.1.1 CLKx / nCLKx Input

For applications that do not require the use of the reference clock input, both CLK and nCLK should be left floating. If the CLK/nCLK input is connected but not used by the device, it is recommended that CLK and nCLK not be driven with active signals.

5.1.1.2 LVCMOS Control Pins

LVCMOS control pins have internal pull-ups. Additional resistance is not required but can be added for additional protection. A 1k Ω resistor can be used.

5.1.2 Outputs

5.1.2.1 LVCMOS Outputs

Any LVCMOS output can be left floating if unused. There should be no trace attached. The mode of the output buffer should be set to tri-stated to avoid any noise being generated.

5.1.2.2 Differential Outputs

All unused differential outputs can be left floating. Renesas recommends that there is no trace attached. Both sides of the differential output pair should be left floating or terminated.

5.1.3 Power Connections

The power connections of the RC32112A can be grouped as shown if all members of the groups are using the same voltage level:

- V_{DD_DIG}
- V_{DDA_FB}
- V_{DDO_Qn} (can share supplies if output frequencies are the same, otherwise keep separated to avoid spur coupling)
 - If all outputs Qn/nQn associated with any particular V_{DDO_Qn} pin are not used, the power pin can be left floating

5.2 Clock Input Interface

The RC32112A accepts both single-ended and differential inputs. For information on input terminations, see [Quick Guide - Output Terminations \(AN-953\)](#).

If you have additional questions on input types not covered in the application discussion, or if you require information about register programming sequences for changing the differential inputs to accept LVCMOS inputs levels, see [Termination - AC Coupling Clock Receivers \(AN-844\)](#) or contact [Renesas Technical Support](#).

5.3 Overdriving the XTAL Interface

The OSCI input can be overdriven by an LVCMOS driver or by one side of a differential driver through an AC coupling capacitor. The OSCI input is internally biased at 1V. The OSCO pin can be left floating. The amplitude of the input signal should be between 500mV and 1.8V and the slew rate should not be less than 0.2V/ns. For 1.8V LVCMOS, inputs can be DC-coupled into the device as shown in [Figure 20](#). For 3.3V LVCMOS inputs, the amplitude must be reduced from full swing to at least half the swing in order to prevent signal interference with the power rail and to reduce internal noise.

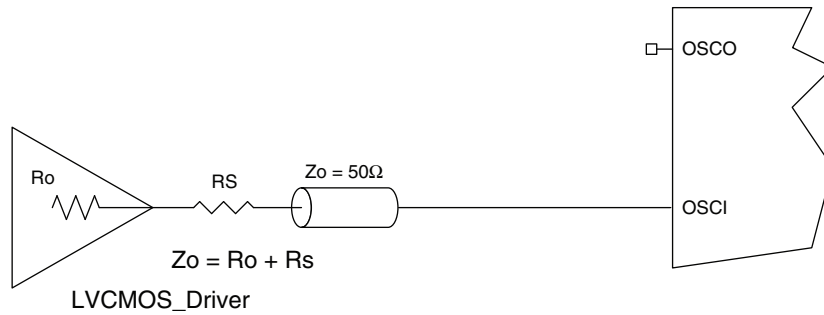

Figure 20. 1.8V LVCMOS Driver to XTAL Input Interface

Figure 21 shows an example of the interface diagram for a high-speed 3.3V LVCMOS driver. This configuration requires that the sum of the output impedance of the driver (R_o) and the series resistance (R_s) equals the transmission line impedance. In addition, matched termination at the crystal input will attenuate the signal in half. This can be done in one of two ways. First, R_1 and R_2 in parallel should equal the transmission line impedance. For most 50Ω applications, R_1 and R_2 can be 100Ω. This can also be accomplished by removing R_1 and changing R_2 to 50Ω. The values of the resistors can be increased to reduce the loading for a slower and weaker LVCMOS driver.

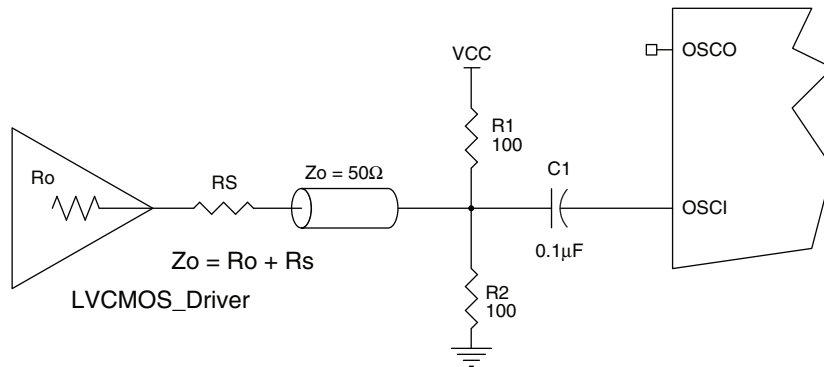

Figure 21. LVCMOS Driver to XTAL Input Interface

Figure 22 shows an example of the interface diagram for an LVPECL driver. This is a standard LVPECL termination with one side of the driver feeding the XTAL_IN input. It is recommended that all components in the schematics be placed in the layout. Though some components may not be used, they can be used for debugging purposes. The datasheet specifications are characterized and confirmed using a quartz crystal as the input.

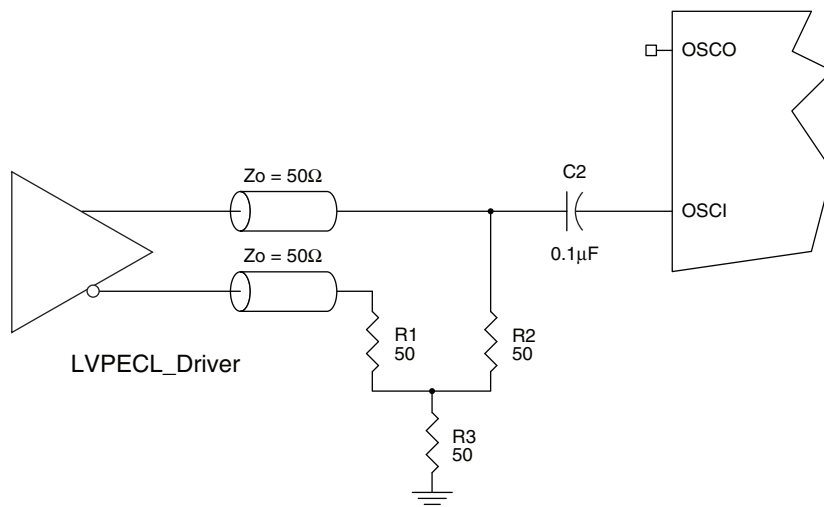

Figure 22. LVPECL Driver to XTAL Input Interface

5.4 Wiring the Differential Input to Accept Single-Ended Levels

For information, see [Differential Input to Accept Single-ended Levels Application Note \(AN-836\)](#).

5.5 Differential Output Termination

For all types of differential protocols, the same termination schemes are recommended (see [Figure 23](#) and [Figure 24](#)). These schemes are the same as normally used for an LVDS output type.

The recommended value for the termination impedance (Z_T) is between 90Ω and 132Ω . The actual value should be selected to match the differential impedance (Z_{DIFF}) of your transmission line. A typical point-to-point LVDS design uses a 100Ω parallel resistor at the receiver and a 100Ω differential transmission-line environment. To avoid any transmission-line reflection issues, the components should be surface-mounted and must be placed as close to the receiver as possible.

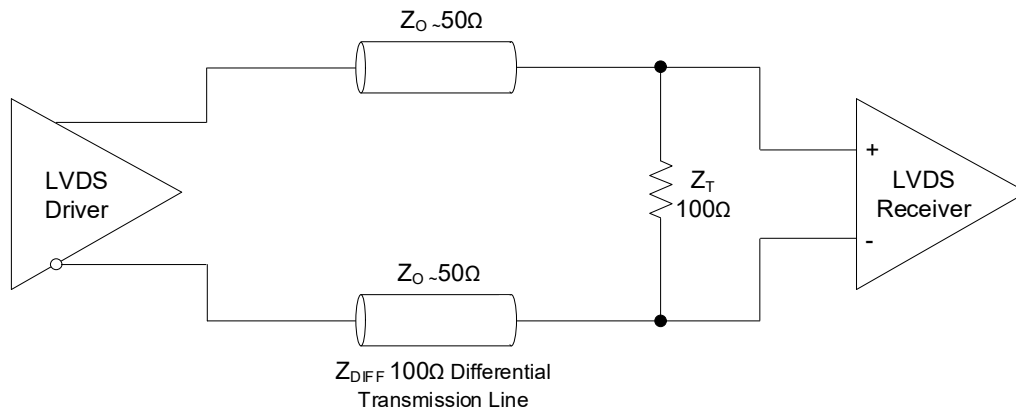

Figure 23. Standard LVDS Termination

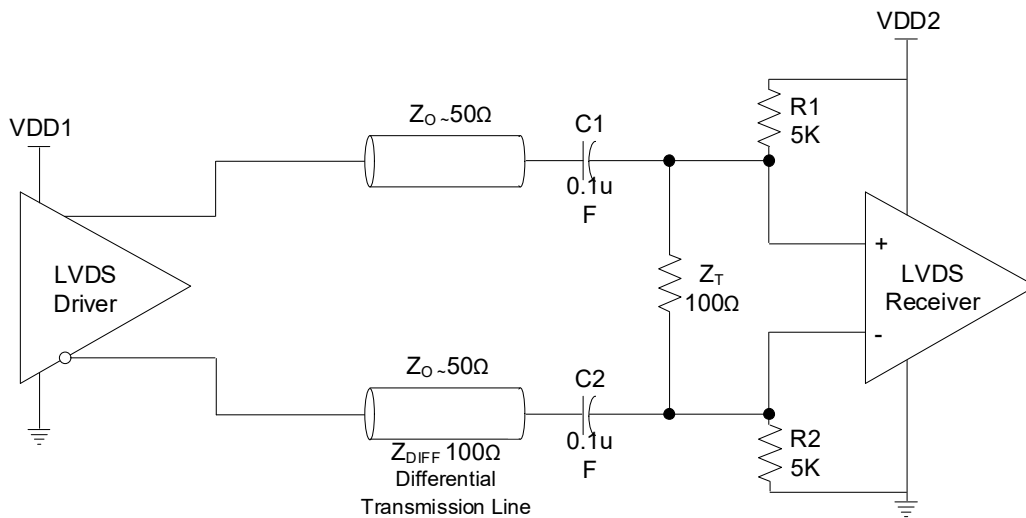

Figure 24. AC Coupled LVDS Termination

For alternate termination schemes, see “LVDS Termination” in [Quick Guide - Output Terminations \(AN-953\)](#), or contact [Renesas](#) for support.

5.6 External I²C Serial EEPROM Recommendation

An external I²C EEPROM can be used to store configuration data and/or to contain device update data. An EEPROM with 8Kbit capacity is sufficient to store a full configuration. However, the recommendation is to use an

EEPROM with a 1Mbit capacity in order to support future device updates. Renesas has validated and recommends the use of the Microchip 24FC1025 or OnSemi CAT24M01 1Mbit EEPROM.

5.7 Schematic and Layout Information

The RC32112A requires external load capacitors to ensure the crystal will resonate at the proper frequency. For recommendations on crystal vendors, please contact [Renesas](#). For recommended values for external tuning capacitors, see [Table 31](#).

Table 31. Recommended Tuning Capacitors for Crystal Input

| Crystal Nominal C _L Value (pF) | Recommended Tuning Capacitor Value (pF) ^[1] | |
|---|--|---------------------|
| | OSCI Capacitor (pF) | OSCO Capacitor (pF) |
| 8 | 2.7 | 2.7 |
| 10 | 13 | 3.3 |
| 12 | 27 | 3.3 |
| 18 ^[2] | 27 | 3.3 |

1. Recommendations are based on 4pF stray capacitance on each leg of the crystal. Adjust according to the PCB capacitance.
2. This will tune the crystal to a CL of 12pF, which is fine when channels are running in Jitter attenuator mode or referenced to an XO. It will present a positive ppm offset for channels running exclusively in Synthesizer mode and referenced only to the crystal.

5.8 Power Considerations

For power and current consumption calculations, see the Renesas [Timing Commander](#) tool.

6. Thermal Information

6.1 VFQFPN EPAD Thermal Release Path

In order to maximize both the removal of heat from the package and the electrical performance, a land pattern must be incorporated on the Printed Circuit Board (PCB) within the footprint of the package corresponding to the exposed metal pad or exposed heat slug on the package, as shown in [Figure 25](#). The solderable area on the PCB, as defined by the solder mask, should be at least the same size/shape as the exposed pad/slug area on the package to maximize the thermal/electrical performance. Sufficient clearance should be designed on the PCB between the outer edges of the land pattern and the inner edges of pad pattern for the leads to avoid any shorts.

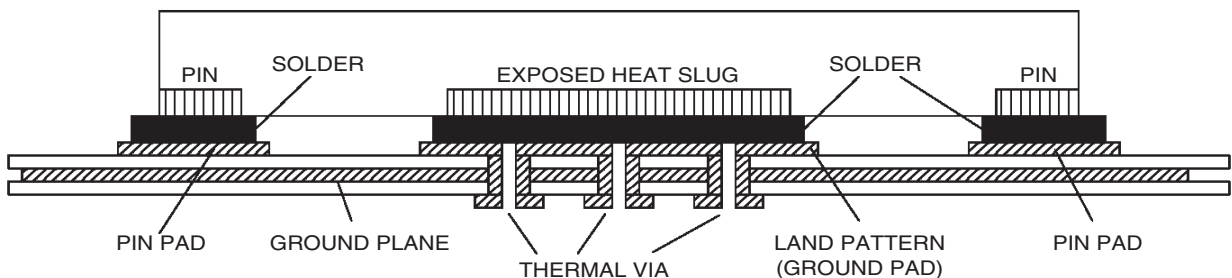

Figure 25. P.C. Assembly for Exposed Pad Thermal Release Path – Side View (Drawing not to Scale)

While the land pattern on the PCB provides a means of heat transfer and electrical grounding from the package to the board through a solder joint, thermal vias are necessary to effectively conduct from the surface of the PCB to the ground plane(s). The land pattern must be connected to ground through these vias. The vias act as “heat pipes”. The number of vias (i.e., “heat pipes”) are application specific and dependent upon the package power dissipation as well as electrical conductivity requirements. Thus, thermal and electrical analysis and/or testing are recommended to determine the minimum number needed.

Maximum thermal and electrical performance is achieved when an array of vias is incorporated in the land pattern. It is recommended to use as many vias connected to ground as possible. It is also recommended that the via diameter should be 12 to 13mils (0.30 to 0.33mm) with 1oz copper via barrel plating. This is desirable to avoid any solder wicking inside the via during the soldering process which may result in voids in solder between the exposed pad/slug and the thermal land. Precautions should be taken to eliminate any solder voids between the exposed heat slug and the land pattern (*Note:* These recommendations are to be used as a guideline only). For additional information, see the application note on the Surface Mount Assembly of Amkor’s Thermally/ Electrically Enhance Lead frame Base Package, Amkor Technology.

6.2 Thermal Characteristics

Table 32. Thermal Characteristics

| Symbol | Parameter | Value | Unit | |
|---------------|---|----------------|-------|------|
| θ_{JA} | Theta J_A . Junction to Ambient Air Thermal Coefficient ^{[1][2]} | 0 m/s air flow | 13.71 | °C/W |
| | | 1 m/s air flow | 10.67 | °C/W |
| | | 2 m/s air flow | 9.46 | °C/W |
| θ_{JB} | Theta J_B . Junction to Board Thermal Coefficient ^[1] | 0.702 | °C/W | |
| θ_{JC} | Theta J_C . Junction to Device Case Thermal Coefficient ^[1] | 12.87 | °C/W | |
| - | Moisture Sensitivity Rating (Per J-STD-020) | 3 | | |

1. Multi-Layer PCB with two ground and two voltage planes.
2. Assumes ePAD is connected to a ground plane using a grid of 9x9 thermal vias.

7. Package Outline Drawings

The package outline drawings are located at the end of this document and are accessible from the [Renesas](#) website (see package links in Ordering Information). The package information is the most current data available and is subject to change without revision of this document.

8. Marking Diagram



- Lines 2 and 3 indicate the part number.
- Line 4:
 - “#” denotes the stepping number.
 - “YYWW” denotes the last two digits of the year and the work week the part was assembled.
 - “\$” indicates the mark code.
- “LOT” denotes the lot number and “COO” the country of origin.

9. Ordering Information

| Part Number | Package Description | MSL Rating | Carrier Type | Temperature Range |
|-----------------------------------|--------------------------------|------------|--|-------------------|
| RC32112AdddGN2#BB0 ^[1] | 10 × 10 × 0.9 mm, 72-VFQFPN | 3 | Tray | -40° to +85°C |
| RC32112AdddGN2#KB0 | 10 × 10 × 0.9 mm, 72-VFQFPN | 3 | Tape and Reel, Pin 1 Orientation: EIA-481-D | -40° to +85°C |

1. Replace “ddd” with the desired pre-programmed configuration code provided by Renesas in response to a custom configuration request or use “000” for unprogrammed parts.

Table 33. Pin 1 Orientation in Tape and Reel Packaging

| Part Number Suffix | Pin 1 Orientation | Illustration |
|--------------------|------------------------|--------------|
| NK#K | Quadrant 2 (EIA-481-D) | |

10. Revision History

| Revision | Date | Description |
|----------|--------------|---|
| 1.03 | Jan 29, 2024 | <ul style="list-style-type: none"> Updated the descriptions of pins 9, 11, 13, 15, and 18 in Pin Descriptions. |
| 1.02 | Jun 22, 2023 | <ul style="list-style-type: none"> Updated block diagram in Figure 1 to show DPLL1. Added third bullet to Functional Description. Completed other minor changes. |
| 1.01 | Oct 3, 2022 | <ul style="list-style-type: none"> Updated f_{MAX} and t_{HD1} parameters in Table 21. Removed t_{D1d} and t_{D2} parameters from Table 21. Also deleted footnotes 2 and 3. |
| 1.00 | Jun 3, 2022 | Initial version. |

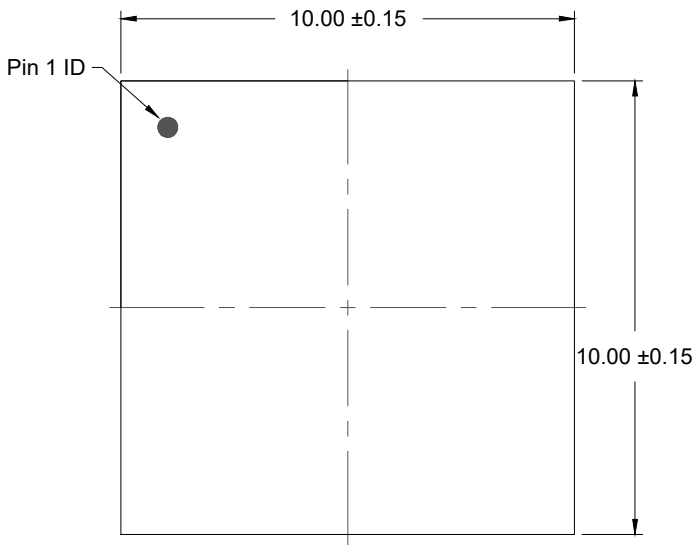

TOP VIEW

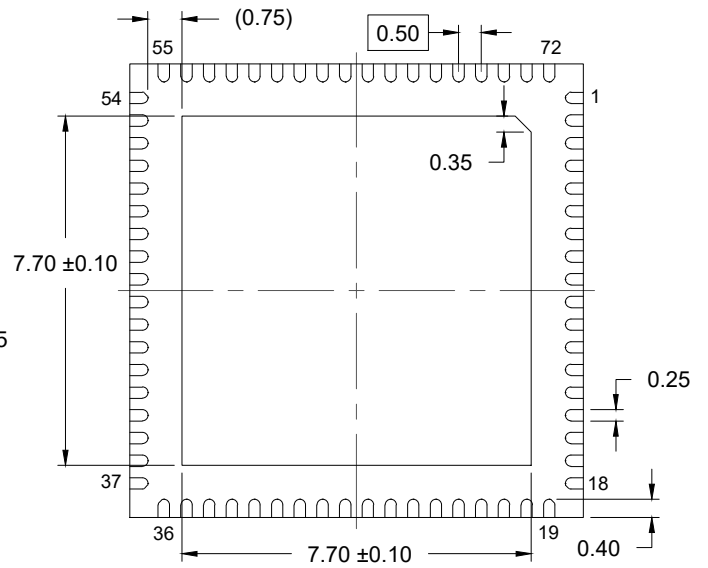

BOTTOM VIEW

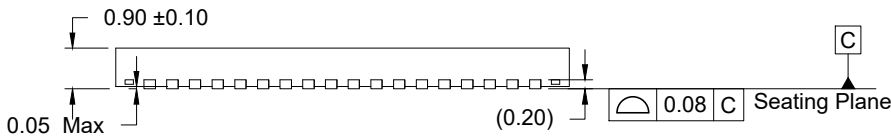

SIDE VIEW

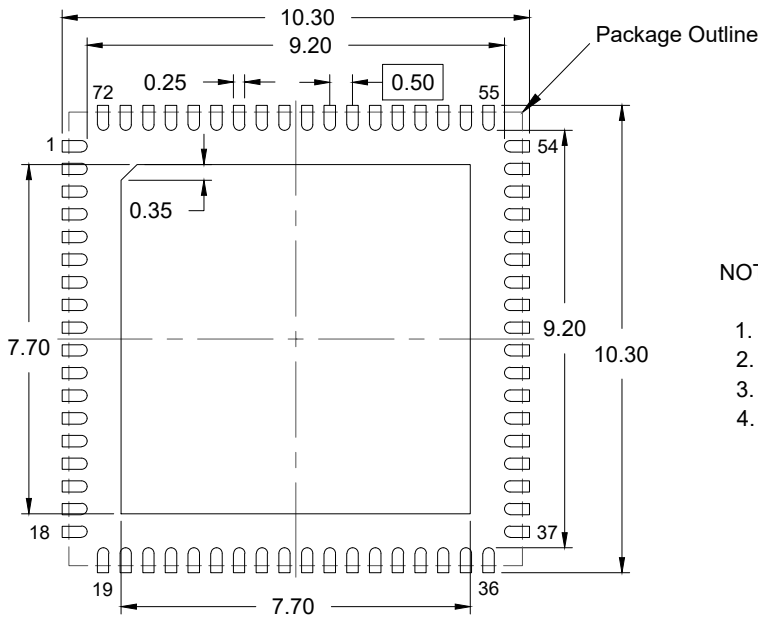

RECOMMENDED LAND PATTERN
 (PCB Top View, NSMD Design)

NOTES:

1. JEDEC compatible.
2. All dimensions are in mm and angles are in degrees.
3. Use ±0.05 mm for the non-toleranced dimensions.
4. Numbers in () are for references only.

IMPORTANT NOTICE AND DISCLAIMER

RENESAS ELECTRONICS CORPORATION AND ITS SUBSIDIARIES (“RENESAS”) PROVIDES TECHNICAL SPECIFICATIONS AND RELIABILITY DATA (INCLUDING DATASHEETS), DESIGN RESOURCES (INCLUDING REFERENCE DESIGNS), APPLICATION OR OTHER DESIGN ADVICE, WEB TOOLS, SAFETY INFORMATION, AND OTHER RESOURCES “AS IS” AND WITH ALL FAULTS, AND DISCLAIMS ALL WARRANTIES, EXPRESS OR IMPLIED, INCLUDING, WITHOUT LIMITATION, ANY IMPLIED WARRANTIES OF MERCHANTABILITY, FITNESS FOR A PARTICULAR PURPOSE, OR NON-INFRINGEMENT OF THIRD-PARTY INTELLECTUAL PROPERTY RIGHTS.

These resources are intended for developers who are designing with Renesas products. You are solely responsible for (1) selecting the appropriate products for your application, (2) designing, validating, and testing your application, and (3) ensuring your application meets applicable standards, and any other safety, security, or other requirements. These resources are subject to change without notice. Renesas grants you permission to use these resources only to develop an application that uses Renesas products. Other reproduction or use of these resources is strictly prohibited. No license is granted to any other Renesas intellectual property or to any third-party intellectual property. Renesas disclaims responsibility for, and you will fully indemnify Renesas and its representatives against, any claims, damages, costs, losses, or liabilities arising from your use of these resources. Renesas' products are provided only subject to Renesas' Terms and Conditions of Sale or other applicable terms agreed to in writing. No use of any Renesas resources expands or otherwise alters any applicable warranties or warranty disclaimers for these products.

(Disclaimer Rev.1.01 Jan 2024)

Corporate Headquarters

TOYOSU FORESIA, 3-2-24 Toyosu,
Koto-ku, Tokyo 135-0061, Japan
www.renesas.com

Trademarks

Renesas and the Renesas logo are trademarks of Renesas Electronics Corporation. All trademarks and registered trademarks are the property of their respective owners.

Contact Information

For further information on a product, technology, the most up-to-date version of a document, or your nearest sales office, please visit www.renesas.com/contact-us/.