

# RAJ2800024H12HPF

R07DS1395EJ0100

## Intelligent Power Device for automotive application

Rev.1.00

Aug 1, 2017

### 1. Overview

#### 1.1 Description

**Family:**

RAJ280002 is 1.6mohm single channel Intelligent Power Devices (IPD) embedded in TO263-7 package. It is N-channel high-side switches with charge pump, diagnostic feedback with proportional load current sense and embedded protection function. Family includes up to 4 devices depending on on-state resistance, input interface combination between current driven and voltage driven.

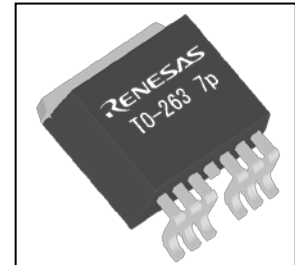

**Scalability:**

Variety of on-state resistance combined with standardized package on pin-out give user high flexibility for unit design depending on target load.

**Robustness:**

Because of advanced protection method, RAJ280002 achieves high robustness against long term and repetitive short circuit condition.

#### 1.2 Features

- Built-in charge pump
- 3.3V compatible logic interface
- Low standby current
- Short circuit protection
  - Shutdown by over current detection
  - Power limitation protection by over load detection (Power limitation: current limitation with delta Tch control)
  - Shutdown by absolute channel over temperature detection
- Built-in diagnostic function
  - Proportional load current sensing
  - Defined fault signal in case of abnormal load condition
- Reverse battery protection by self-turn ON
- Loss of ground protection
- Under voltage lock out
- Active clamp operation at inductive load switch off
- AEC Qualified
- RoHS compliant

#### 1.3 Product summary

Parameter	Symbol	Values
Operating Voltage	$V_{CC}$	4.5V ~ 28V
Under voltage shutdown	$V_{CC}(U_V)$	Max. 4.5V
On-state resistance at 25°C	$R_{on}$	Max. 2.0mohm, Typ. 1.6mohm
Inductive load switch-off energy dissipation single pulse	EAS	1700mJ
;Inductive load switch-off energy dissipation repetitive pulse	EAR	840mJ
Minimum Over current detection current	IL(SC)	150A

## 1.4 Application

- All types of resistive, inductive and capacitive loads, especially for high current loads.
- Power management application such as Power distribution switches, Heaters, glow plugs, etc

**NOTE: The information contained in this document is the one that was obtained when the document was issued, and may be subject to change.**

## 2. Ordering Information

Part No.	Lead plating	Packing	Package
RAJ2800024H12HPF	Pure Matte Sn	Tape 800pcs/reel	TO263-7

### 3. Specification

#### 3.1 Block Diagram

##### 3.1.1 Nch High-side Single Channel Device Block Diagram

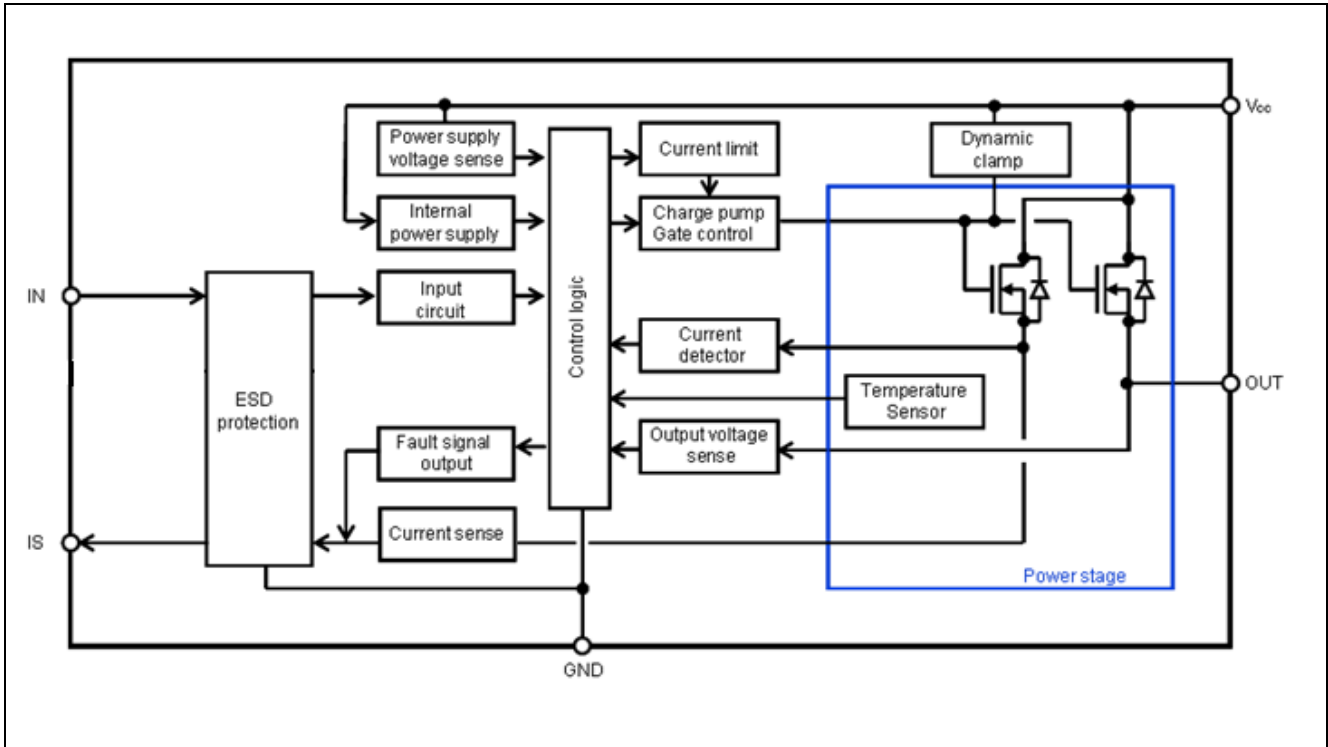

#### Voltage and Current Definition

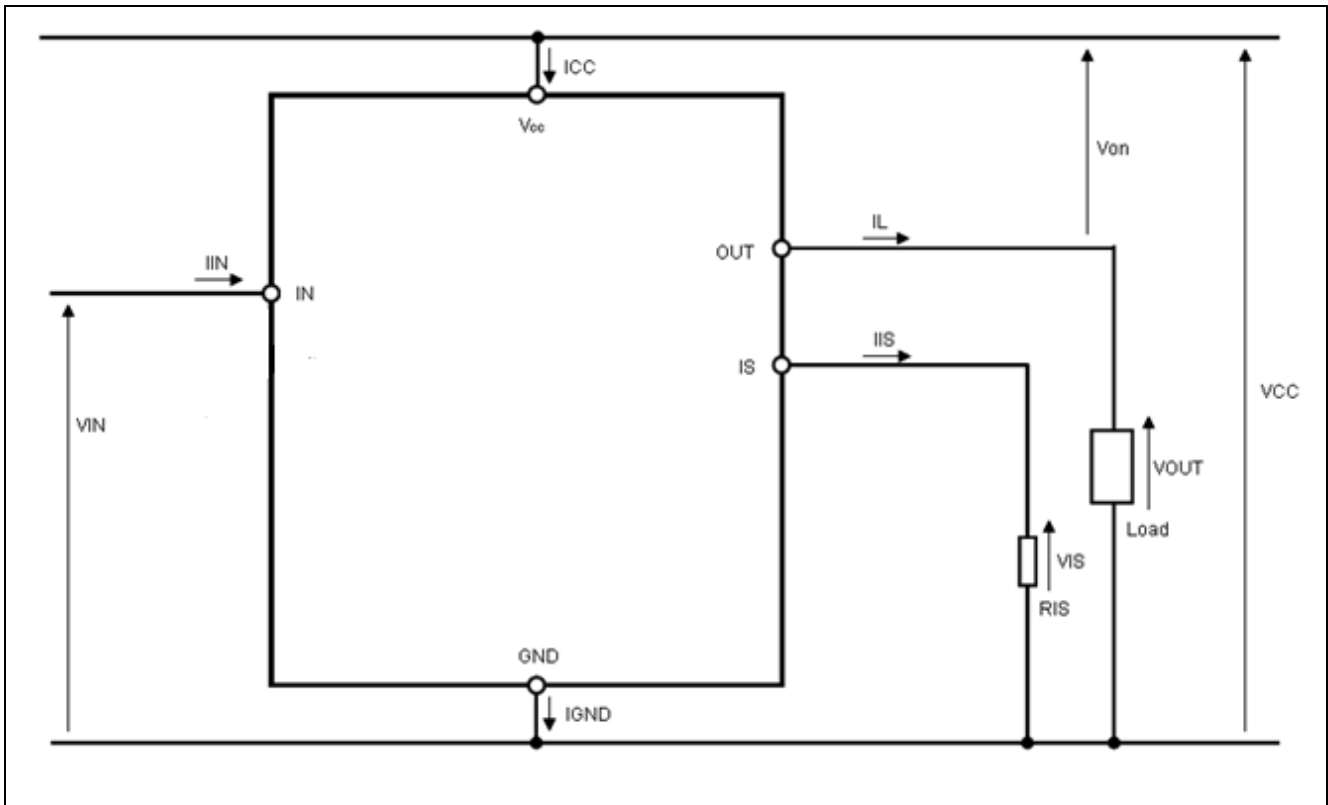

## 3.2 Pin Configuration

### 3.2.1 TO263-7 Pin Configuration

Pin No.	Terminal Name
1	GND
2	IN
3	IS
4, Tab	VCC
5	OUT
6	OUT
7	OUT

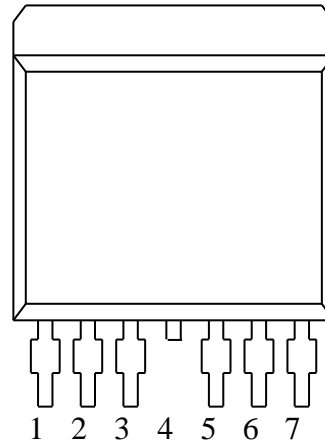

#### Pin function

Terminal Name	Pin function	Recommended connection
GND	Ground connection	Connected to GND through a 100 Ohm resistor
IN	Input signal for channel activation Active high	Connected to MCU port through a 2k-50K serial resistor
IS	Current sense and Diagnosis output signal	Connected to GND through a 1K-6K resistor <sup>1)</sup>
OUT	Protected high-side power output	Connected to load with 50-100nf capacitor in parallel
VCC	Positive power supply for logic supply as well as output power supply	Connected to battery voltage with 100nf capacitor in parallel

1) A resistor is necessary to satisfy standby current characteristics

### 3.3 Absolute Maximum Ratings

Stress values that exceed those listed here may cause permanent damage to the device. Exposure to absolute maximum rating condition for extended periods may affect device reliability.

Integrated protection functions are designed to prevent IC destruction under fault condition described in the data sheet. Fault conditions are considered as out of normal operation. Protection function shall not be intended to be used for continuous repetitive operation.

Ta=25degreeC, unless other specified

Parameter	Symbol	Rating	Unit	Test Condition		
Vcc Voltage	V <sub>CC</sub>	28	V			
Vcc Voltage at reverse battery condition	-V <sub>CC</sub>	-16	V	At nominal load current, t<2min, R <sub>IN</sub> =2kohm, R <sub>IS</sub> =1kohm, R <sub>GND</sub> =100ohm		
Vcc voltage under Load Dump condition	V <sub>load dump</sub>	42	V	R <sub>I</sub> =1ohm, R <sub>L</sub> =Nominal load, R <sub>IS</sub> =1kohm, R <sub>IN</sub> =2kohm, R <sub>GND</sub> =100ohm, t <sub>d</sub> =400ms,		
Load Current	I <sub>L</sub>	Self limited	A			
Total power dissipation for whole device (DC)	P <sub>D</sub>	3.10	W	Ta=85degreeC, Device on 50mmx50mmx1.5mm epoxy PCB FR4 with 6 cm <sup>2</sup> of 70 um copper area		
Voltage at IN pin	V <sub>IN</sub>	-2 ~ 16	V	DC R <sub>IN</sub> =2kohm		
		-16		At reverse battery condition, t<2min, R <sub>IN</sub> =2kohm		
IN pin current	I <sub>IN</sub>	10	mA	DC		
Voltage at IS pin	V <sub>IS</sub>	-2 ~ V <sub>CC</sub>	V	DC R <sub>IS</sub> =1kohm		
		-16	V	At reverse battery condition, t<2min, R <sub>L</sub> = Nominal load, R <sub>IS</sub> =1kohm		
IS Reverse current at reverse battery condition	I <sub>IS(Rev)</sub>	-30	mA	At reverse battery condition, t<2min, R <sub>L</sub> = Nominal load		
Channel Temperature	T <sub>ch</sub>	-40 to +150	degreeC			
Storage Temperature	T <sub>stg</sub>	-55 to +150	degreeC			
ESD susceptibility	V <sub>ESD</sub>	2000	V	HBM	AEC-Q100-002 std. R=1.5kohm, C=100pF	All pin
		4000			IEC61000-4-2 std. R=330ohm, C=150pF, 100nF at VCC and OUT	VCC, OUT
		200	V	MM	AEC-Q100-003 std. R=0ohm, C=200pF	
Inductive load switch-off energy dissipation single pulse	EAS	1700	mJ	VCC=13.5V, T <sub>ch,start</sub> <150degreeC, R <sub>L</sub> =Nominal load, Refer to 3.6.7		
Inductive load switch-off energy dissipation repetitive pulse	EAR	840	mJ	VCC=13.5V, T <sub>ch,start</sub> =85degreeC, R <sub>L</sub> =Nominal load, Refer to 3.6.7		

Remark) All voltages refer to ground pin of the device

### 3.4 Thermal Characteristics

Parameter	Symbol	Min	Typ	Max	Unit	Test Condition
Thermal characteristics	Rth(ch-a)		21		degree C/W	According to JEDEC JESD51-2, -5, -7 on FR4 2s2p board
	Rth(ch-c)		0.21		degree C/W	

### 3.5 Electrical Characteristics

#### Operation function

Tch=-40 to 150degreeC, Vcc=7 to 18V, unless other wise specified

Parameter	Symbol	Min	Typ	Max	Unit	Test Condition	
Operating Voltage	V <sub>CC</sub>	4.5		28	V	V <sub>IN</sub> =4.5V, RL=Nominal load, Refer to 3.6.7	
Operating current	I <sub>GND</sub>		2.5	5	mA	V <sub>IN</sub> =4.5V	
Output Leakage current	I <sub>L(off)</sub>			0.5	μA	Tch=25°C	VCC=13.5V, VIN=0V, VIS=0V, VOUT=0V, VGND=0V
				13		Tch=-40~125°C	
Standby current	I <sub>CC(off)</sub>			0.5	μA	Tch=25°C	VCC=13.5V, VIN=0V, VIS=0V, VOUT=0V, VGND=0V
				1.5		Tch=-40~85°C	
On-state resistance	R <sub>on</sub>		1.6	2.0	mohm	Tch=25°C	IL= Nominal current, Refer to 3.6.7, VIN>2.5V
				3.7		Tch=150°C	
Low level IN pin voltage	V <sub>IL</sub>			0.8	V		
High level IN pin voltage	V <sub>IH</sub>	2.5			V		
Low level IN pin current	I <sub>IL</sub>	2		30	μA	V <sub>IN</sub> =0.8V	
High level IN pin current	I <sub>IH</sub>	2		30	μA	V <sub>IN</sub> =2.5V	
Clamping IN pin voltage <sup>1)</sup>	V <sub>ZIN</sub>	5	6		V		
Operating current at cranking	I <sub>GND(cr)</sub>		0.4		mA	VCC=3.2V, RGND=100ohm, Pulse duration=24ms, IL= Nominal current, Refer to 3.6.7	
Cranking mode voltage	V <sub>CC(cr)</sub>			4.5	V		
On-state resistance at cranking	R <sub>on(cr)</sub>			8	mohm	VCC=3.2V, RGND=100ohm, Tch=25°C, Pulse duration=24ms, IL= Nominal current, Refer to 3.6.7	
Operating Voltage range for cranking	V <sub>CC(Uv,cr)</sub>	3.2				RGND=100ohm, Tch=25°C, Pulse duration=24ms, IL=Nominal current Refer to 3.6.7	
Under voltage shutdown	V <sub>CC(Uv)</sub>			4.5	V		
Under voltage restart	V <sub>CC(Cpr)</sub>			4.5	V		
Turn on time	ton		500	1000	μs	VCC=13.5V, RL=Nominal load, Refer to 3.6.7	
Turn on delay time	td(on)		100	200	μs		
Turn off time	toff		310	800	μs		
Turn off delay time	td(off)		200	500	μs		
Slew rate on	dV/dton		0.05	0.1	V/μs		
Slew rate off	-dV/dtoff		0.14	0.3	V/μs		
Turn on energy loss <sup>1)</sup>	Eon		30		mJ		
Turn off energy loss <sup>1)</sup>	Eoff		11		mJ	VCC=13.5V, Tch=25°C, RL=Nominal load, Refer to 3.6.7	
Driving capability <sup>1)</sup>	Dr(cap)	75			mohm	Tch=25°C, VCC=8~16V	
		100				Tch=105°C, VCC=8~16V	

Remark) All voltages refer to ground pin of the device

1) not subjected production test, guaranteed by design

## Protection function

Tch=-40 to 150degreeC, Vcc=7 to 18V, unless other wise specified

Parameter	Symbol	Min	Typ	Max	Unit	Test Condition	
Over current detection current	IL(SC)	150	260		A	VCC=13.5V, Von=5V, Tch=25°C	
Current limitation under power limitation toggling	IL(CL)		90		A	VCC=13.5V	
Sense current output trigger threshold	Von(CL1)		1.0		V	VCC=13.5V	
Current limitation trigger threshold during on-state	Von(CL2)		0.3		V	VCC=13.5V	
Turn-on check delay after input signal positive slope	td(CL)		1.6		ms	VCC=13.5V	
Absolute thermal shutdown temperature	aTth	150			°C		
Power limitation thermal shutdown temperature	dTth		40		°C		
Power limitation restart temperature	dTth, restart		19		°C		
Output clamp at inductive load switch off	Von,clamp	30		40	V	VCC=13.5V, IL=40mA, Tch=25°C	
Output current while GND disconnection	IL(GND)			1	mA	IIN=0A, IGND=0A, IIS=0A	
On-state resistance at reverse battery condition	Ron(rev)			2.5	mohm	Tch=25°C	VCC=-13.5V, IL=Nominal current, Refer to 3.6.7
				4.6		Tch=150°C	
Gnd current at reverse battery condition	IGND(rev)		-2		mA	VCC=-16V, Tch=25 °C	

Remark) All voltages refer to ground pin of the device



## Diagnosis function

Tch=-40 to 150degreeC, Vcc=7 to 18V, VIN=4.5V, unless otherwise specified

Parameter	Symbol	Min	Typ	Max	Unit	Test Condition
Current sense ratio	KILIS	35000	70000	110000		IL= 16.5 A
		40000	70000	105000		IL= 33 A
Current sense drift depend on temperature	dKILIS	-20		20	%	VCC=13.5V, Tch,start=25°C, IL =33A, Refer to 3.6.7
Sense current offset current	lis,offset			50	μA	IL=0A, Tch =25deg
Sense voltage under fault condition	Vis,fault	4.5	5.6	7.0	V	RIS=1kohm
Load current to output sense current	IL,min	3.5			A	VCC=13.5V, Tch=25degreeC, IIS>1uA
Sense current settling time after input signal positive slope	tsis(on)		500	1100	μs	VCC=13.5V, VIN=0V to 4.5V, IL/IIS=KILIS, RL=Nominal load, Refer to 3.6.7
Sense current settling time after input signal negative slope <sup>1)</sup>	tsis(off)			10	μs	VIN=4.5V to 0V
Sense current settling time during on-state <sup>1)</sup>	tsis(LC)			50	μs	RL= 2 * Nominal load to Nominal load, Refer to 3.6.7
Fault signal delay after over current detection <sup>1)</sup>	tdsc(fault)			10	μs	VIN=0V to 4.5V, IL=IL(SC)
Fault signal delay after power limitation valid <sup>1)</sup>	tdpl(fault)			10	μs	Von>Von(CL1)
Fault signal delay after power limitation invalid <sup>1)</sup>	tdpl(off)			30	μs	Von<Von(CL1)
Fault signal delay after absolute thermal shutdown <sup>1)</sup>	tdot(fault)			10	μs	VIS→VIS,fault
Fault signal delay after input negative slope <sup>1)</sup>	tdoff(fault)			10	μs	VIN=4.5V to 0V

Remark) All voltages refer to ground pin of the device

1) not subjected production test, guaranteed by design

### 3.6 Feature Description

#### 3.6.1 Driving Circuit

The high-side output is turned on, if the input pin is over  $V_{IH}$ . The high-side output is turned off, if the input pin is open or the input pin is below  $V_{IL}$ . Threshold is designed between  $V_{IH}$  min and  $V_{IL}$  max with hysteresis. IN terminal is pulled down with constant current source.

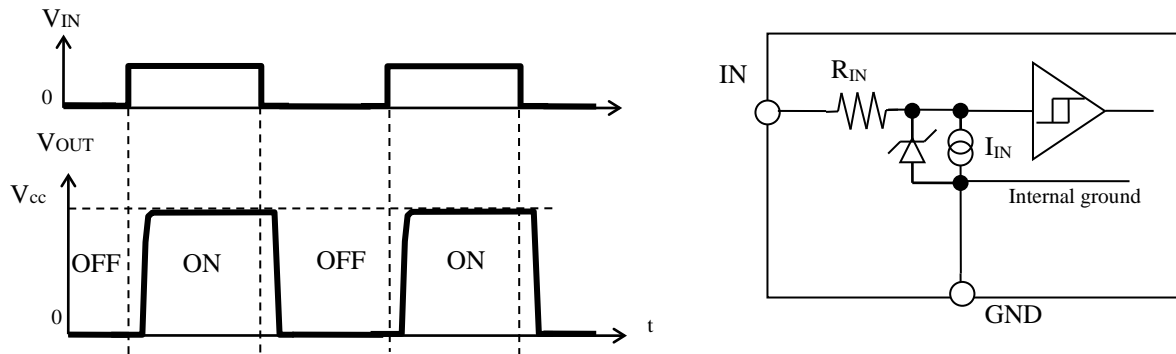

Switching a resistive load

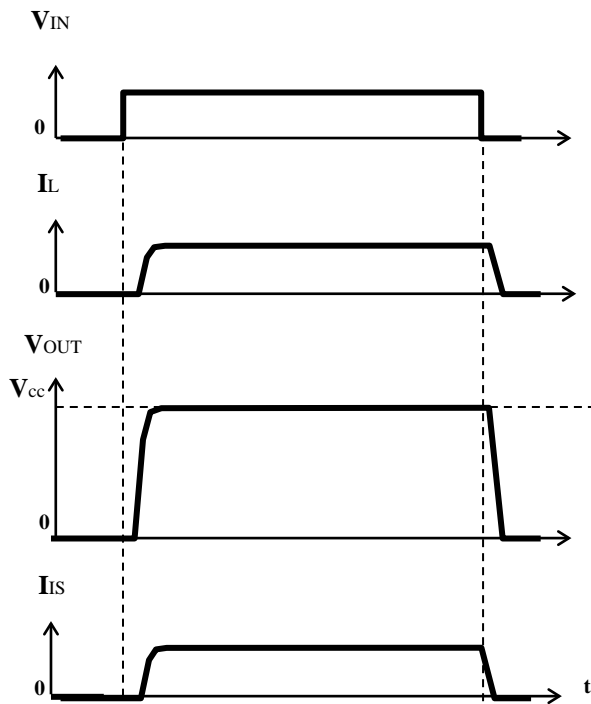

switching lamps

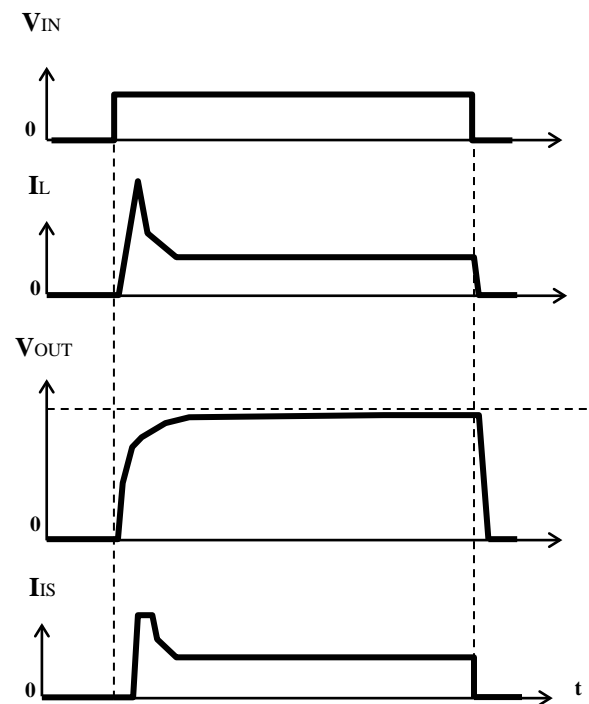

Switching an inductive load

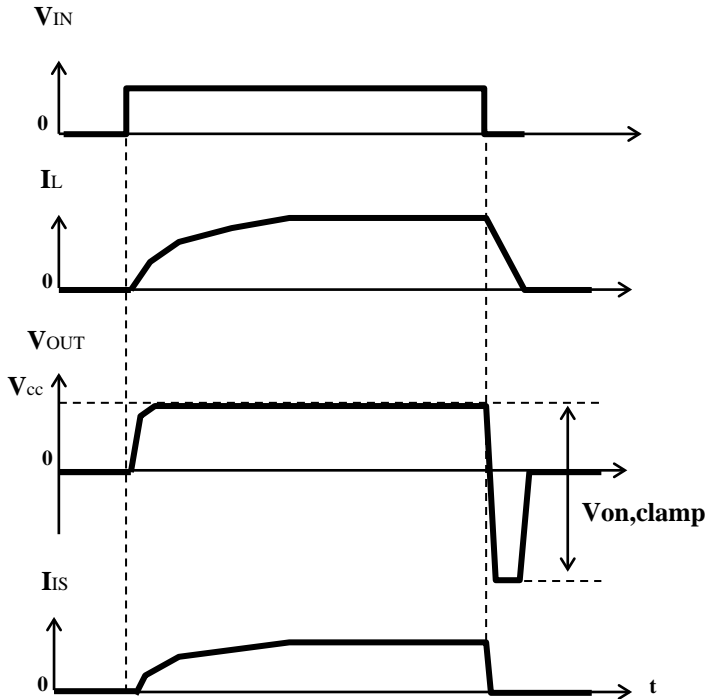

The dynamic clamp circuit works only when the inductive load is switched off. When the inductive load is switched off, the voltage of OUT falls below 0V. The gate voltage of SW1 is then nearly equal to GND. Next, the voltage at the source of SW1 (= gate of output MOS) falls below the GND voltage.

SW1 is turned on, and the clamp diode is connected to the gate of the output MOS, activating the dynamic clamp circuit.

When the over-voltage is applied to VCC, the gate voltage and source voltage of SW1 are both nearly equal to GND. SW1 is not turned on, the clamp diode is not connected to the gate of the output MOS, and the dynamic clamp circuit is not activated.

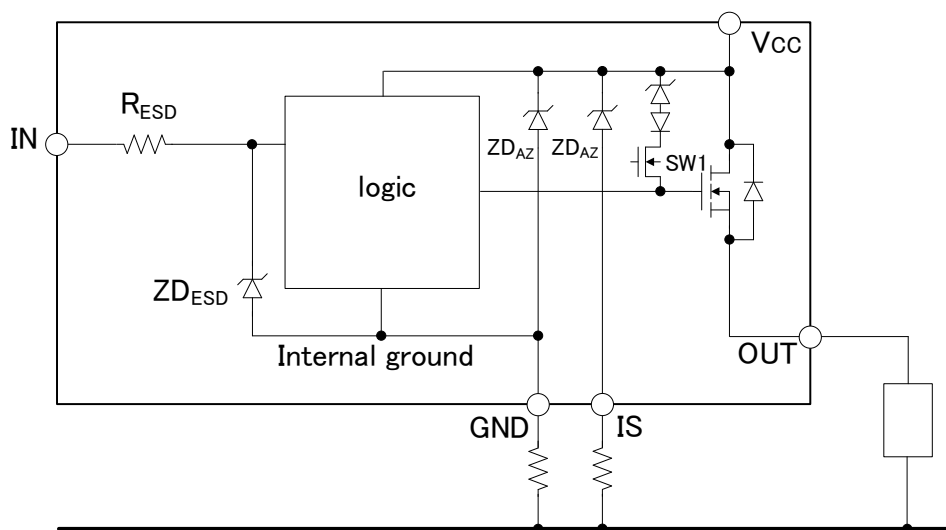

### 3.6.2 Device behavior at over voltage condition

In case of supply voltage greater than  $V_{load}$  dump, logic part is clamped by  $ZD_{AZ}$  (35V min). And current through of logic part is limited by external ground resistor. In addition, the power transistor switches off in order to protect the load from over voltage. Permanent supply voltage than  $V_{load}$  dump must not be applied to VCC.

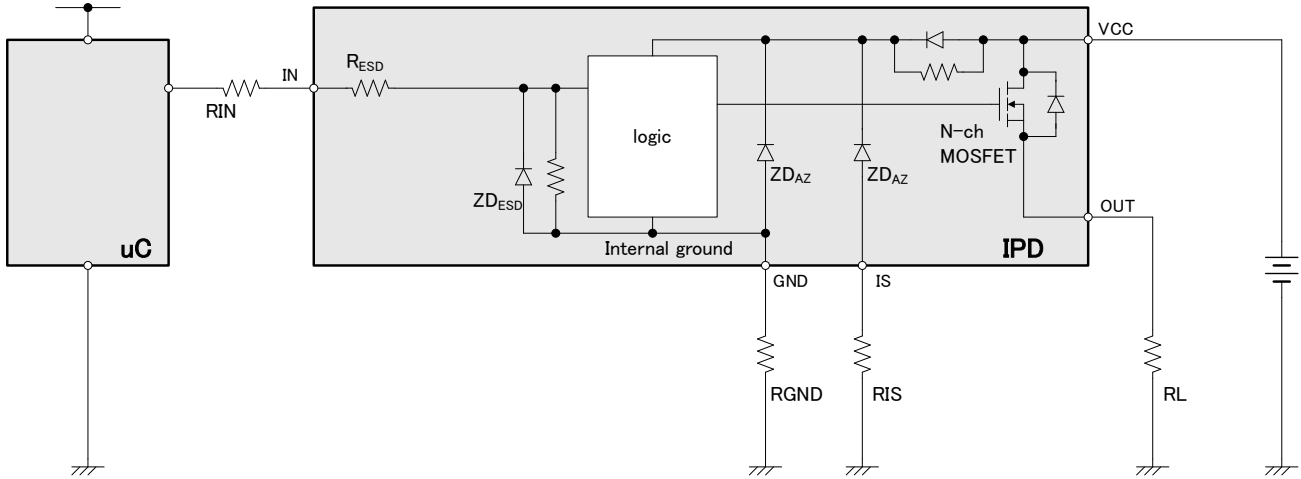

### 3.6.3 Device behavior at low voltage condition

If the voltage supply ( $V_{CC} - V_{IN}$ ) goes down under  $V_{CC}(Uv)$ , the device outputs shuts down. If voltage supply ( $V_{CC} - V_{IN}$ ) increase over  $V_{CC}(Cpr)$ , the device outputs turns back on automatically. The device keeps off state after under voltage shutdown. The IS output is cleared during off-state.

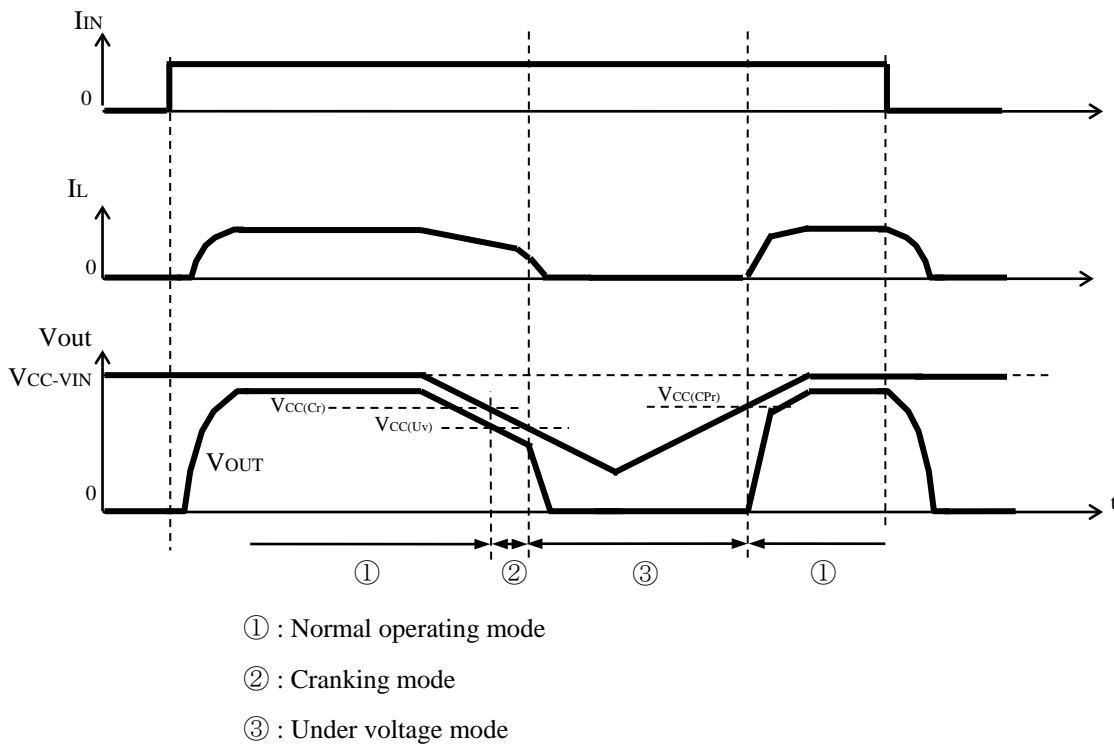

Availability of each function in each mode

○: Enable, ×: Disable

	Function	①	②	③	Note
Normal operation	Turn on	○	×	×	
Normal operation	Turn off	○	○		
Normal operation	Keep on-state	○	○ <sup>(*)</sup>	×	<sup>(*)</sup> Ron is defined as Ron(Cr).
Normal operation	KILIS function	○	×	×	In case of Von < Von(CL1)
Diagnosis	Von(CL1), td(CL)	○	×	×	Refer to 3.6.5
Protection	IL(SC)	○	×	×	Refer to 3.6.5
Protection	Von(CL2)	○	×	×	Refer to 3.6.5
Protection	aTch	○	○		Refer to 3.6.5
Protection	dTch	○	×	×	Refer to 3.6.5
Protection	Von(CL1)	×	○	○	Refer to 3.6.5

Definition of on-state resistance at cranking

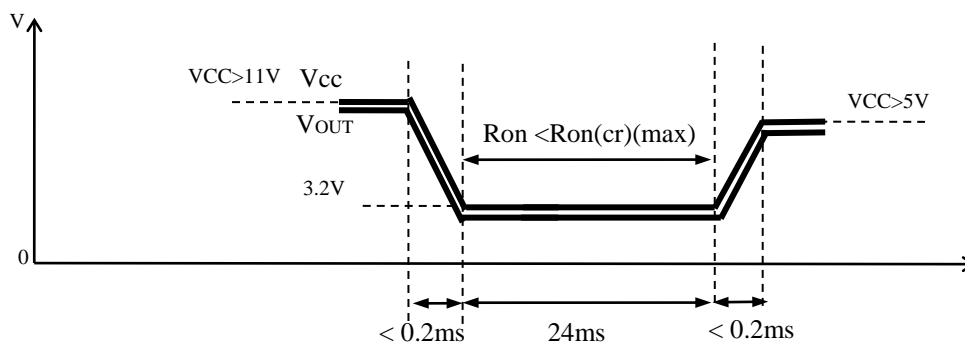

3.6.4 Loss of Ground protection

In case of complete loss of the device ground connection, but connected load ground, the device securely changes to off if VIN was initially greater than VIH state or keeps off state if VIN was initially lower than VIL state.

In case of device loss of ground, IN terminal will/ could/ might be at VCC voltage?

### 3.6.5 Short circuit protection

#### Turn-on in an over load condition including short circuit condition

The device shuts down automatically when condition (a) or (c) is detected. The sense pin output Vis,fault. Shutdown is latched until the next reset via input pin. The device shuts down automatically when condition (b) is detected. The device restarts automatically in power limitation mode. The sense pin outputs Vis,fault when (d) is detected.

- (a)  $IL > IL(SC)$
- (b)  $\Delta T_{ch} > dT_{th}$
- (c)  $T_{ch} > aT_{th}$
- (d)  $V_{on} > V_{on}(CL1)$  after  $t_d(CL)$

#### Over load condition including short circuit condition during on-state

The device runs automatically into power limitation mode when condition (e) is detected once after  $V_{on} < V_{on}(CL2)$ . The device shuts down automatically when condition (f) is detected. The device restarts automatically in power limitation mode. The sense pin output Vis,fault during power limitation mode. The device shuts down automatically when condition (g) or (h) is detected. The sense pin output Vis,fault. Shutdown is latched until the next reset via input pin.

- (e)  $V_{on} > V_{on}(CL2)$
- (f)  $\Delta T_{ch} > dT_{th}$
- (g)  $T_{ch} > aT_{th}$
- (h)  $IL > IL(SC)$

#### Power limitation control

Current limitation control with  $IL(CL)$  when auto restart from  $\Delta T_{ch}$  protection.

During toggling mode due to  $\Delta T_{ch}$  protection, if  $V_{on} > V_{on}(CL1)$  or if the current is limited to  $IL(CL)$ , the sense pin output Vis, fault. If  $V_{on} < V_{on}(CL2)$  and if the short current is not high enough to reach  $IL(CL)$  during toggling mode with  $\Delta T_{ch}$  protection, then the sense pin outputs sense current at on-state and Vis,fault at off state.

#### delta Tch

Junction temperature differences between thermal sensors of power area.

### 3.6.6 Diagnostic signal

Truth table

	Input	Output	Diagnostic output
Normal Operation	H	VCC	IIS = IL/KILIS
	L	L <sup>1)</sup>	L <sup>2)</sup>
Shutdown by over current detection	H	L <sup>1)</sup>	Vis,fault <sup>3)</sup>
	L	L <sup>1)</sup>	L <sup>2)</sup>
Power limitation	H	VOUT <sup>6)</sup>	IIS = IL/KILIS in case of Von<Von(CL1) Vis,fault <sup>4)</sup> in case of Von>Von(CL1)
		L <sup>1)</sup>	Vis,fault <sup>4)</sup>
	L	L <sup>1)</sup>	L <sup>2)</sup>
Shutdown by over absolute channel temperature detection	H	L <sup>1)</sup>	Vis,fault <sup>5)</sup>
	L	L <sup>1)</sup>	L <sup>2)</sup>
Short circuit to VCC	H	VCC	<IIS
	L	VOUT <sup>7)</sup>	L <sup>2)</sup>

- 1) In case of OUT terminal is connected to GND via load.
- 2) In case of IS terminal is connected to GND via resistor.
- 3) IS terminal keeps Vis,fault as long as input signal activate after the over current detection.
- 4) IS terminal keeps Vis,fault during power limitation if Von>Von(CL1).
- 5) IS terminal keeps Vis,fault as long as input signal activate after over absolute channel temperature detection.
- 6) VOUT depends on the short circuit condition.
- 7) VOUT depends on the ratio of VCC-OUT-GND resistive component.

#### Current sense output

The device output analog feedback current proportional to output current from IS pin. In the case of much higher current than nominal load current, current sense output is saturated.

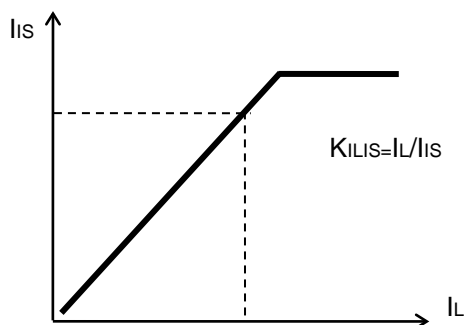

Sense voltage setting time

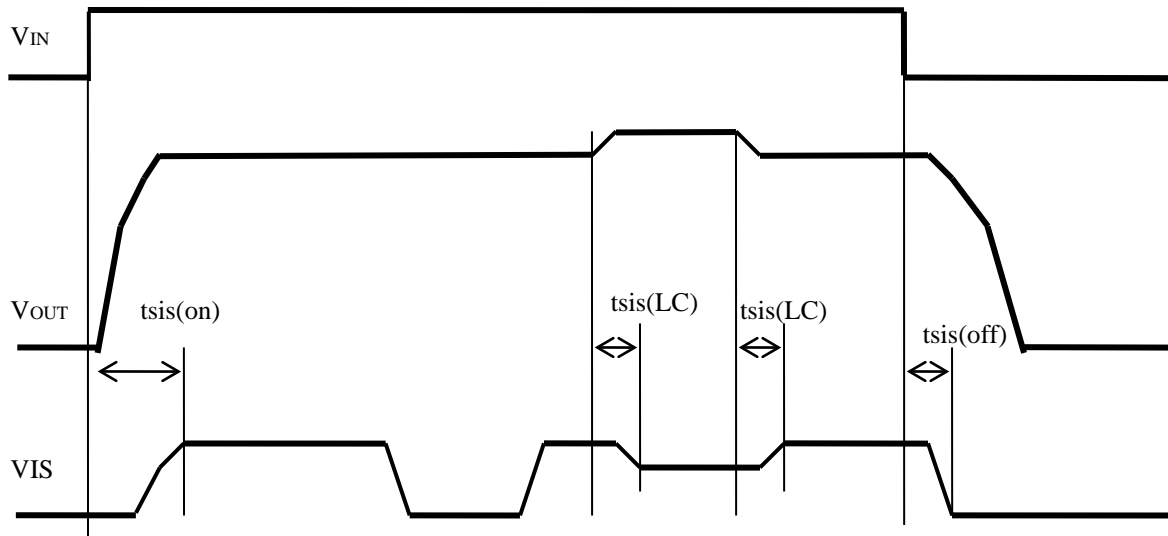

Fault signal delay time at over current detection

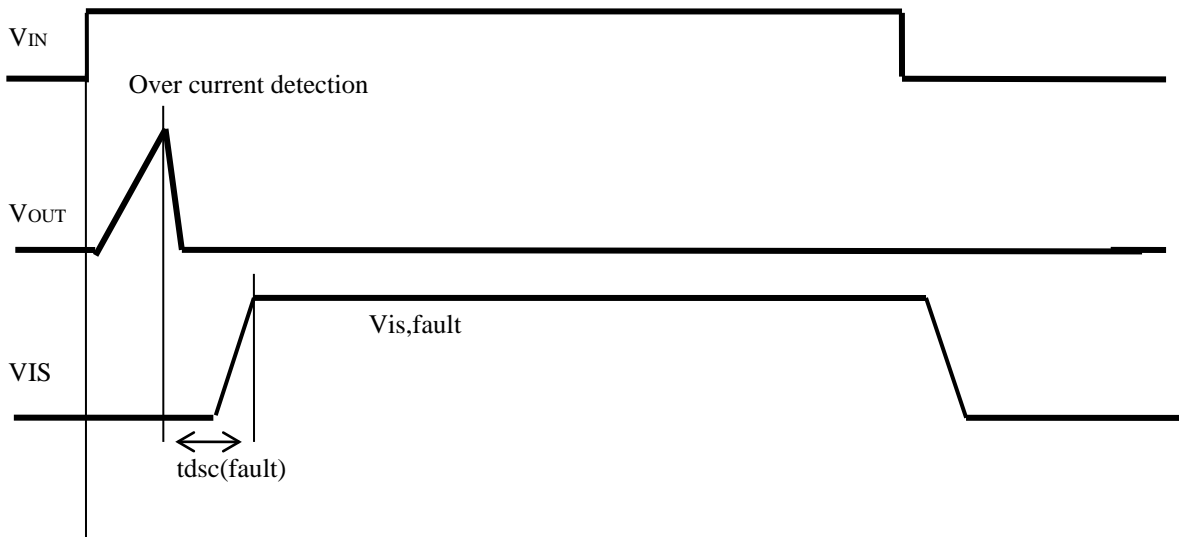



**Fault signal delay time at power limitation**

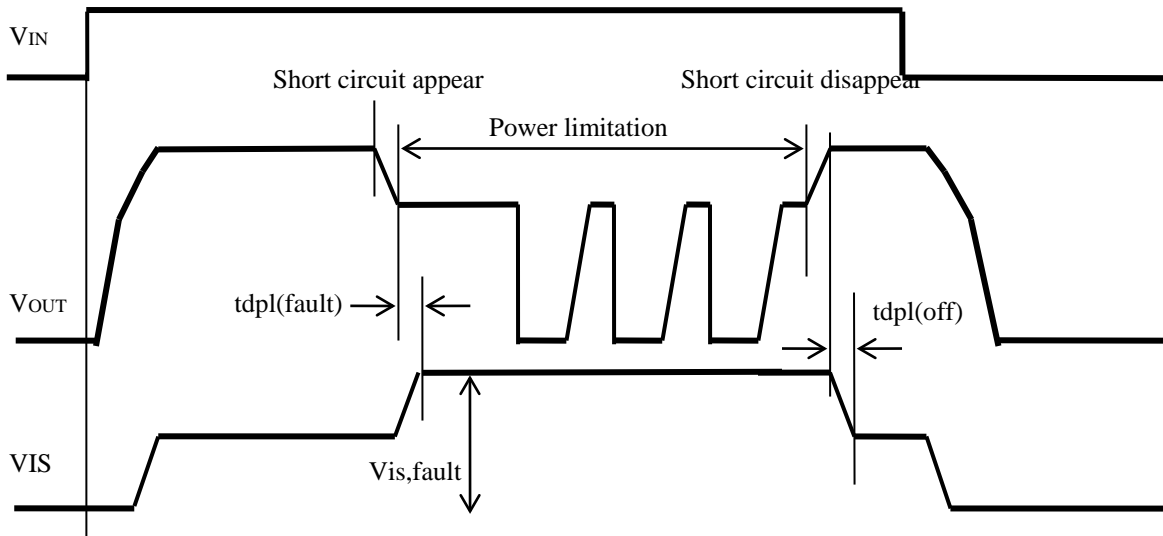

**Fault signal delay time at over absolute channel temperature detection**

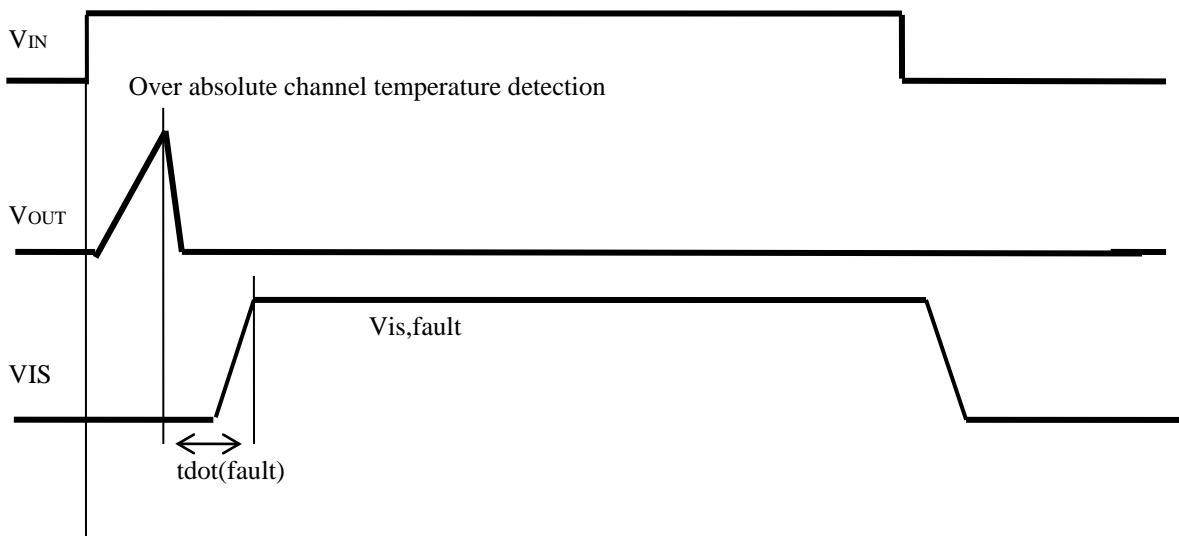

**3.6.7 Nominal load and nominal current**

Parameter	Values	Condition
Nominal load	0.5ohm	$T_j \leq 150^\circ\text{C}$
Nominal current	33A	$T_j \leq 150^\circ\text{C}$

### 3.6.8 Driving Capability

Driving Capability is specified as load impedance. Over current detection characteristics is designed above Driving Capability characteristics. If estimated load impedance which comes from peak inrush current is lower than Driving Capability characteristics, this means, the device does not detect inrush current as over current and does not shutdown the output. Depend on the conditions, Power Limitation function may work during inrush current. If estimated load impedance which comes from peak inrush current is lower than Driving Capability characteristics, Power limitation disappear within 30ms. This parameter does not mean that the device can drive the resistive load up to Driving Capability characteristics.

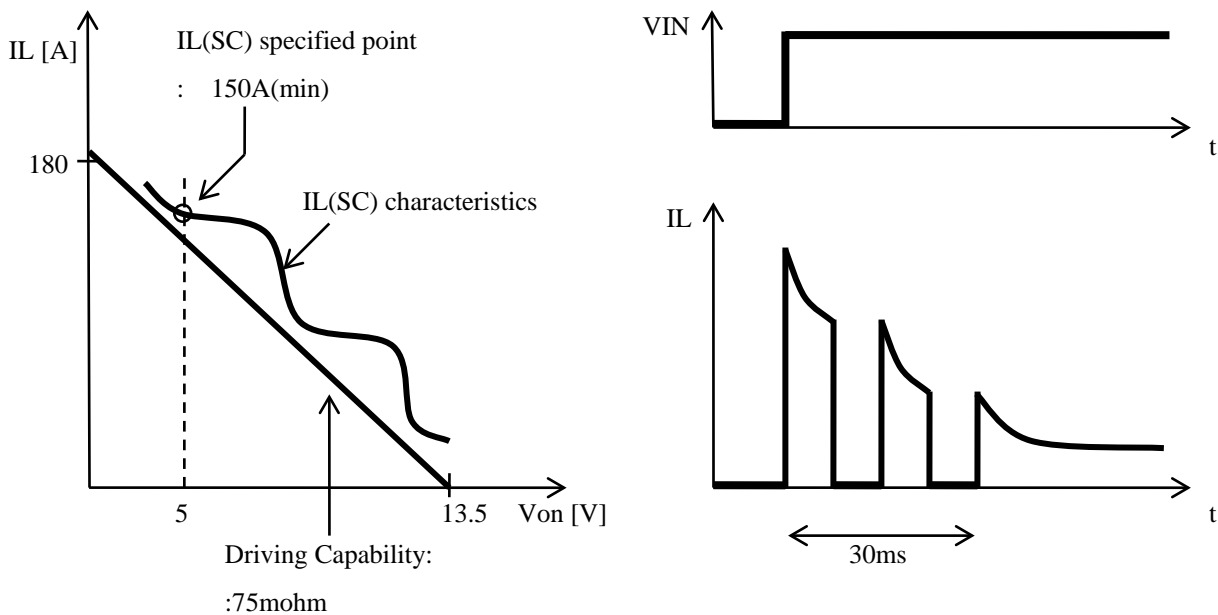

### 3.6.9 Cross current protection in case of H-bridge high side usage

In case of using High side driver in H-bridge circuit, High side driver protects High side driver itself and also low side driver from high power dissipation by cross current when low side driver switching on.

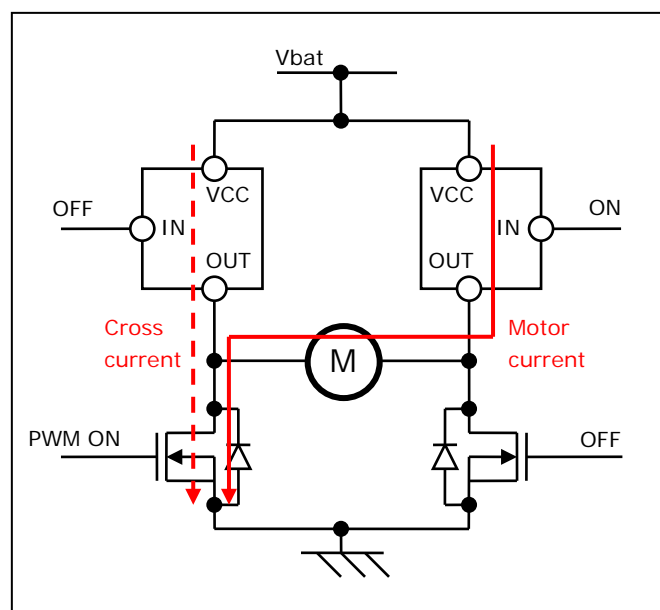

### 3.6.10 Reverse Battery Protection by turn on the output

In case of a reverse battery is applied to the device, the N-ch MOSFET will turn on only if reverse current flow from GND pin. The reverse current through the N-ch MOSFET has to be limited by the connected load.  $I_{GND(rev)}$  is limited internally approx. 2mA even without external  $R_{GND}$ . Reverse current flow from IN, IS should be limited by external component such as recommendation value in Pin function, refer 3.2 Pin configuration.

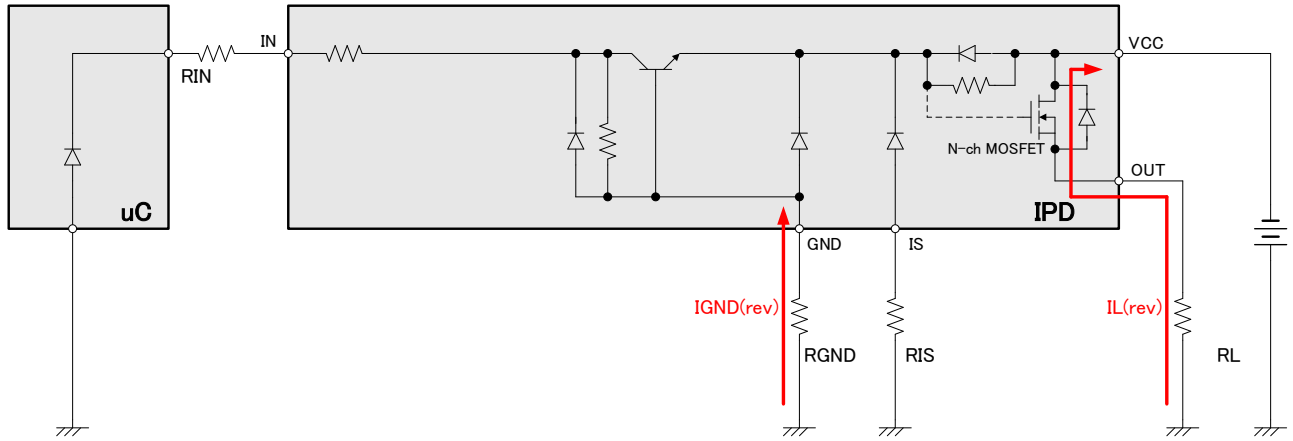

### 3.6.11 Measurement condition

#### Switching waveform of OUT terminal

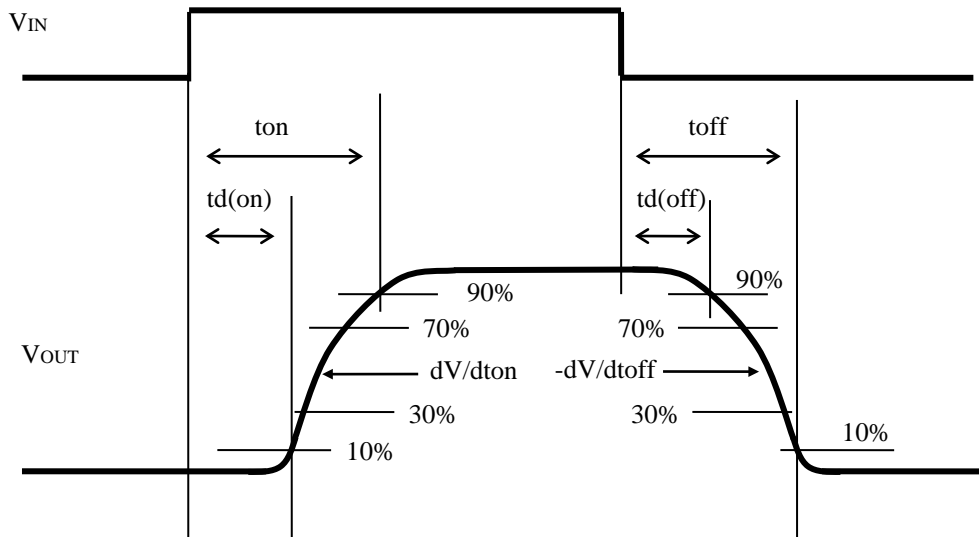

3.7 Package drawing

UNIT:mm

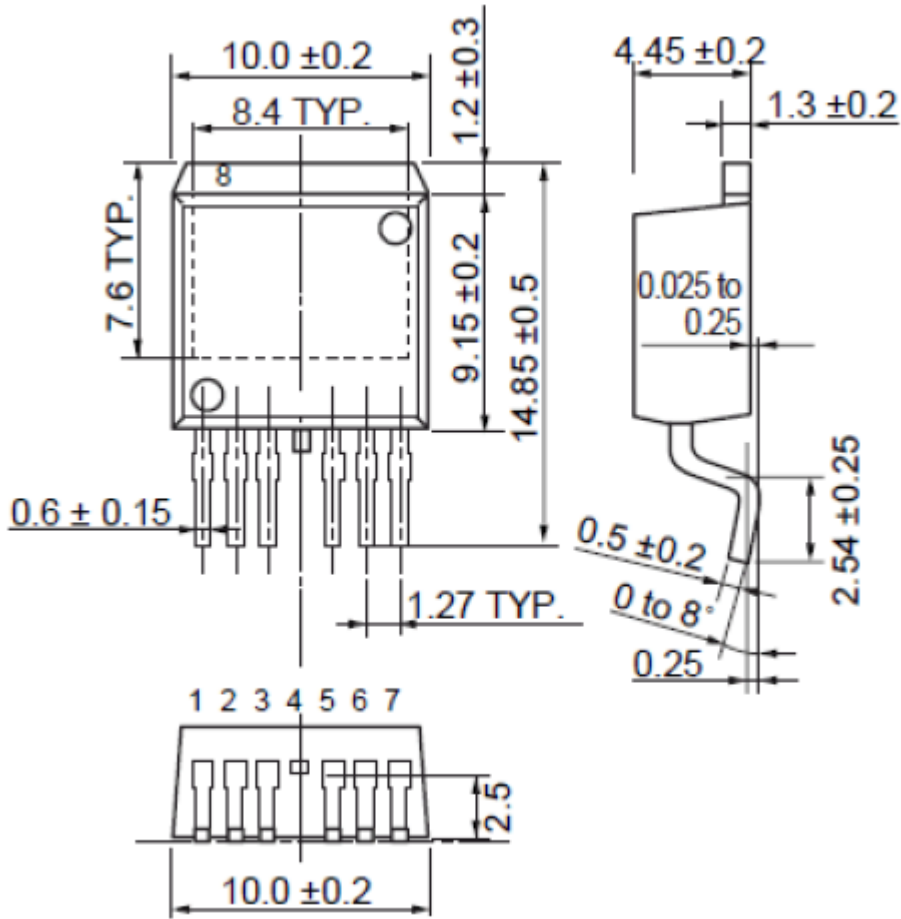

### 3.8 Taping information

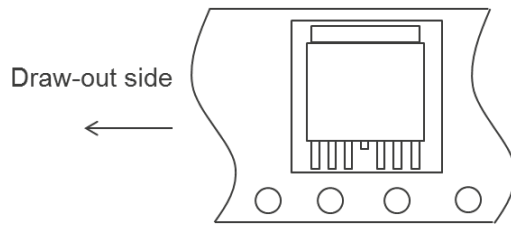

### 3.9 Marking information

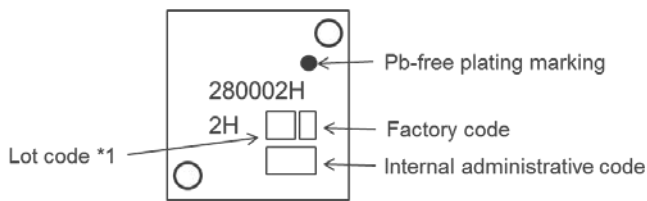

Note: \*1. Composition of the lot code



4 Typical characteristics

Output Leakage current per channel  
VS. Channel TEMPERATURE

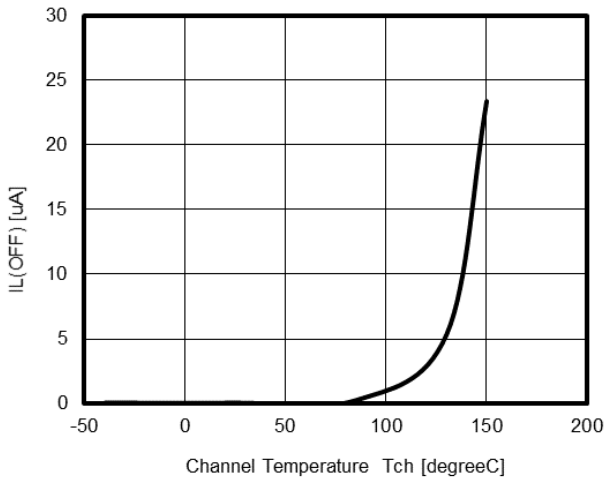

Standby current  
VS. Channel TEMPERATURE

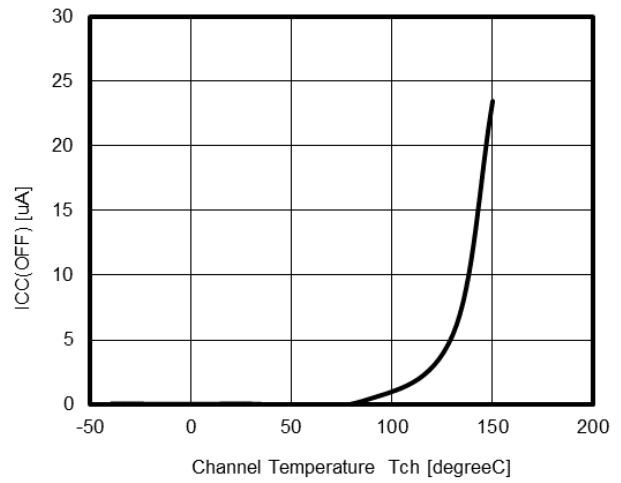

On-state resistance per channel  
VS. Channel TEMPERATURE

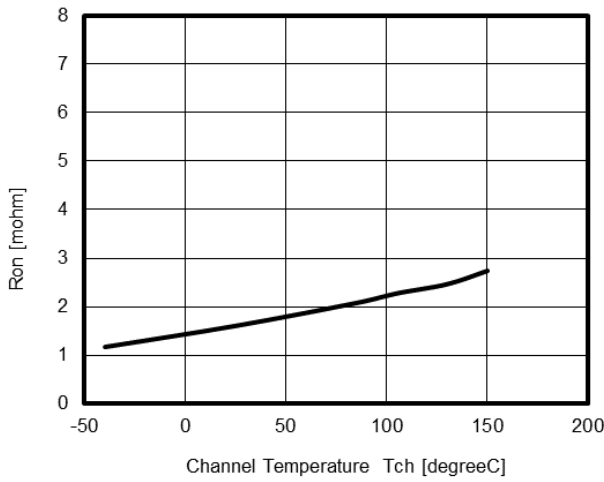

Operating current  
VS. Channel TEMPERATURE

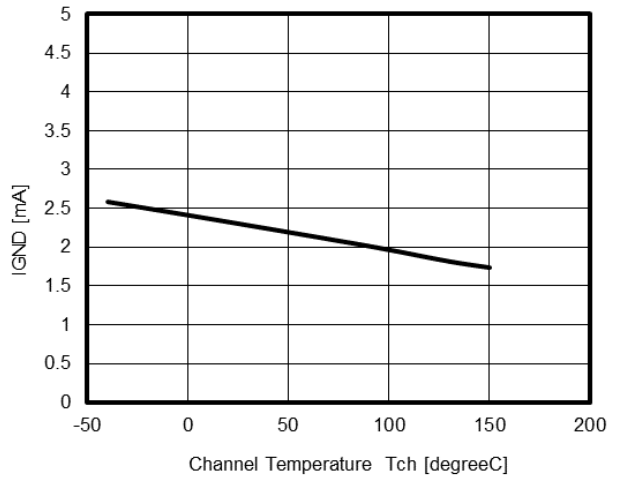

High level IN pin current  
VS. Channel TEMPERATURE

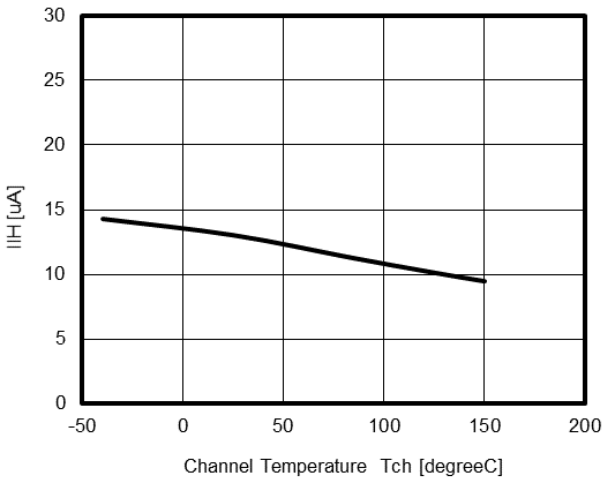

Low level IN pin current  
VS. Channel TEMPERATURE

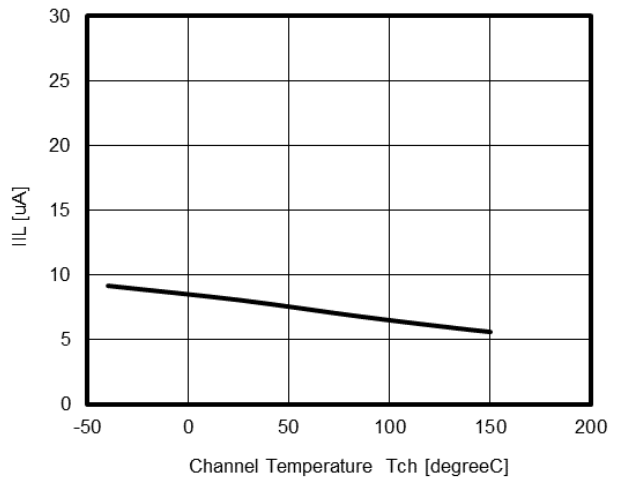

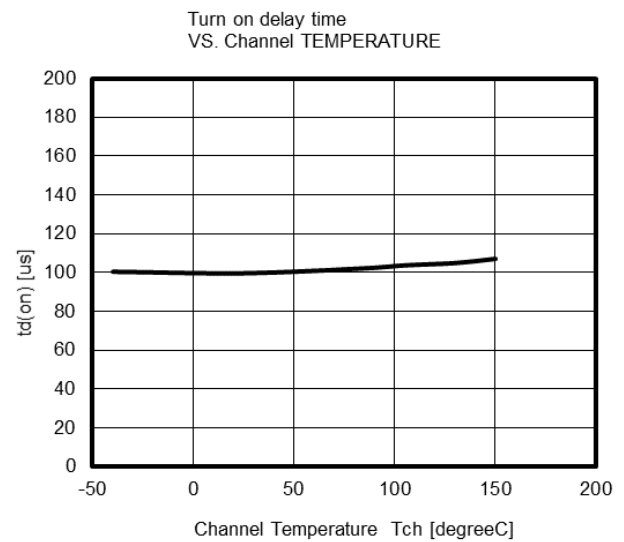
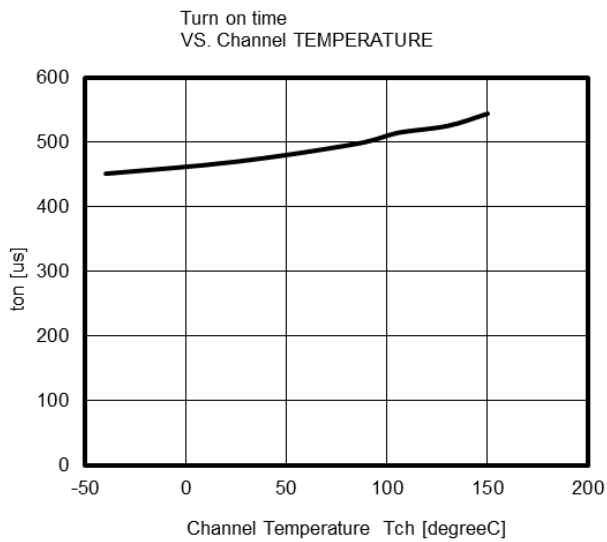
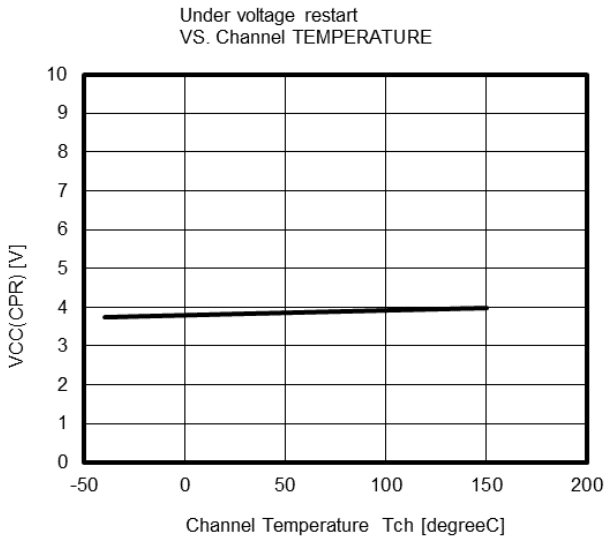
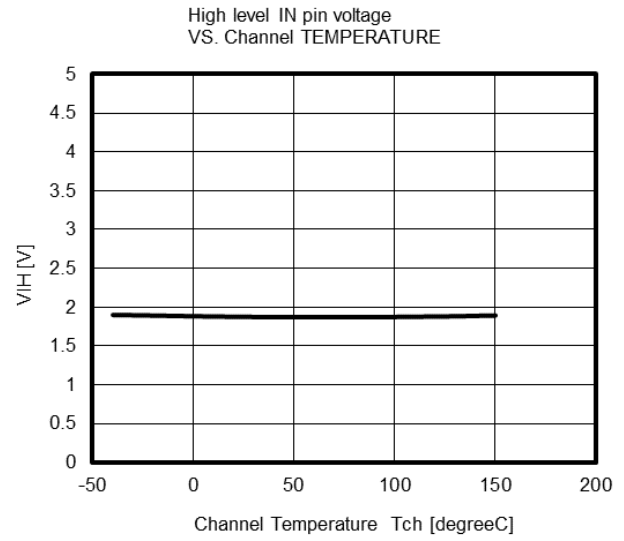
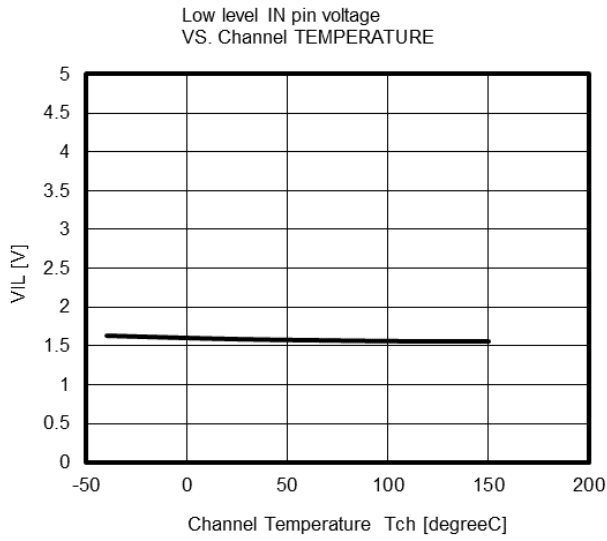

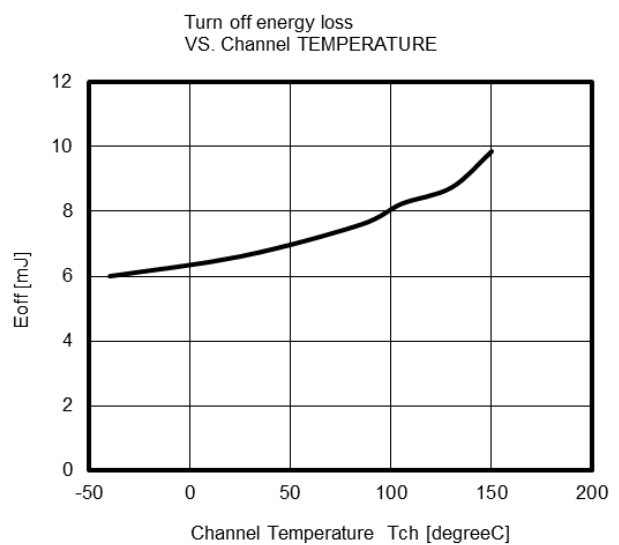
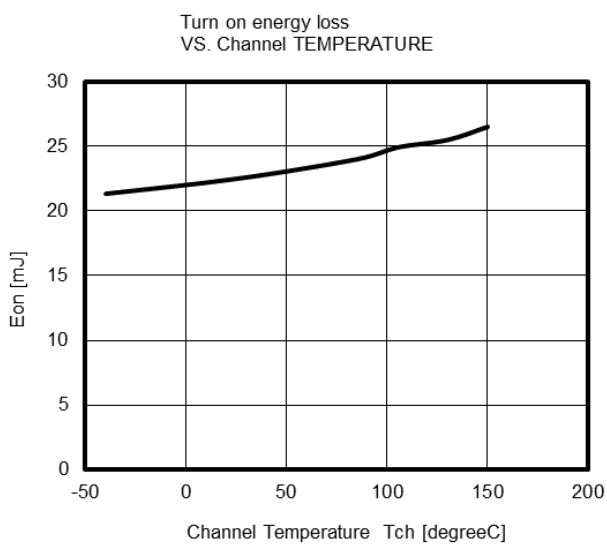
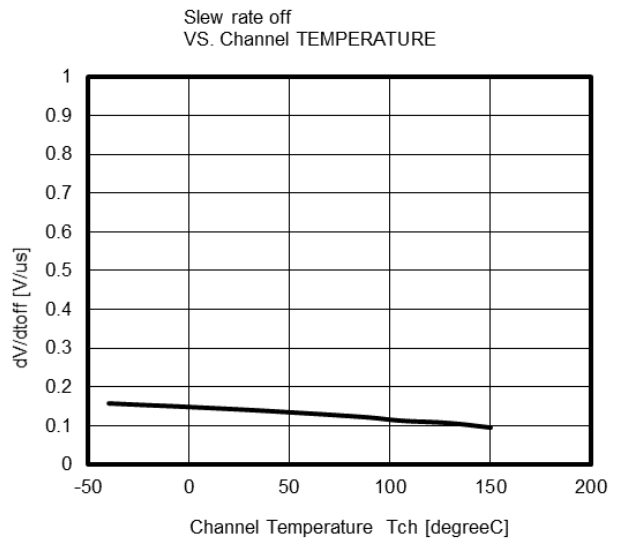
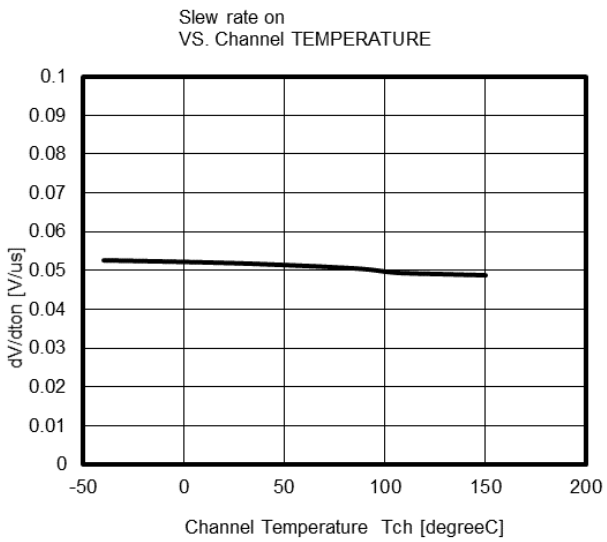
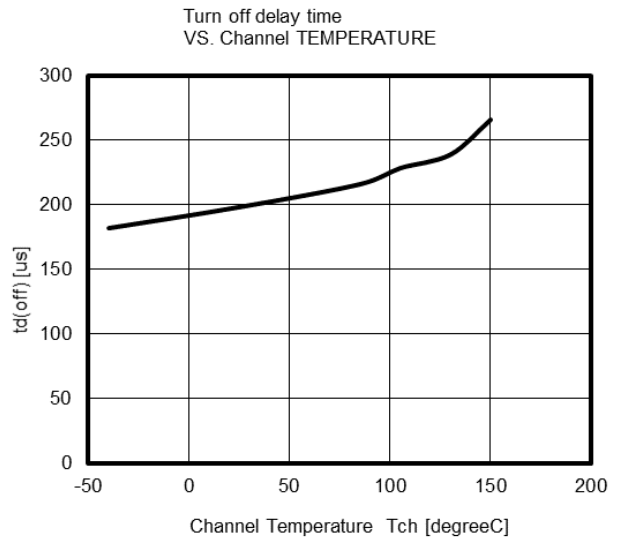
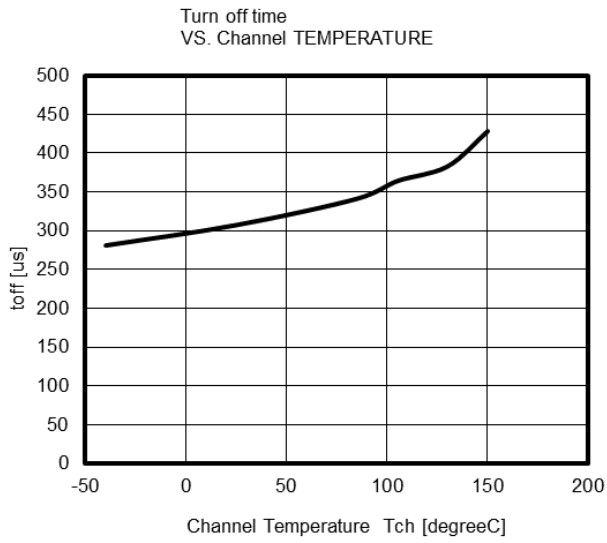



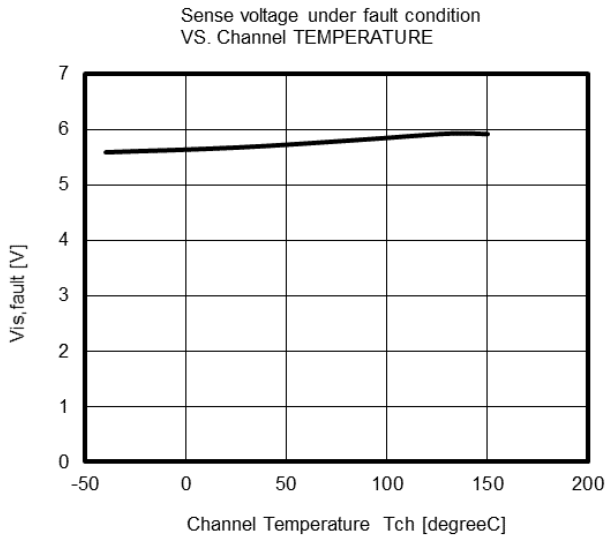
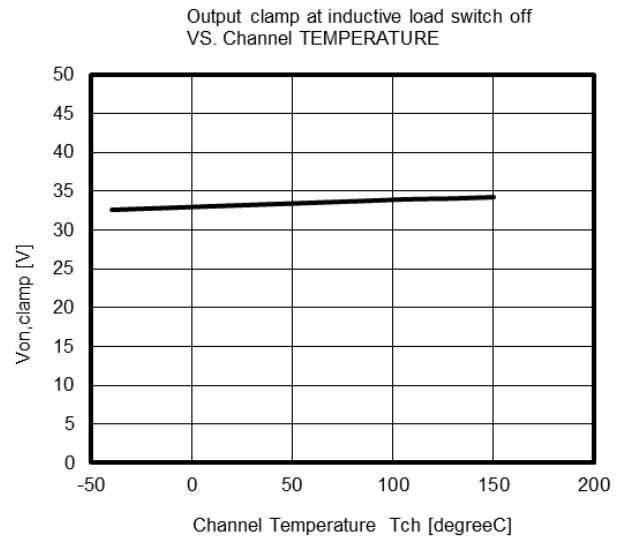
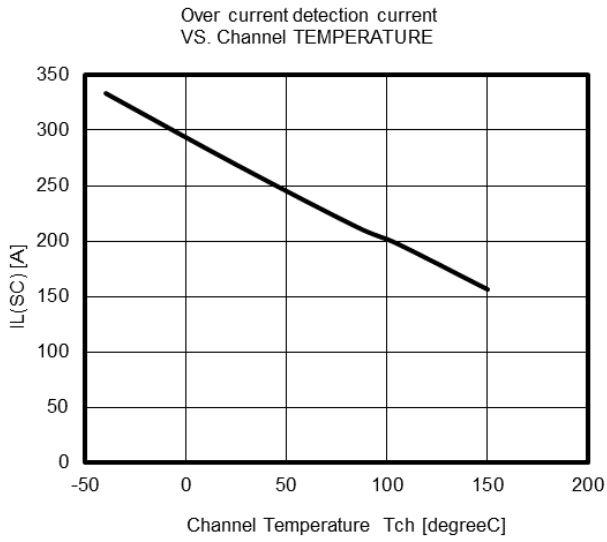

5 Thermal characteristics

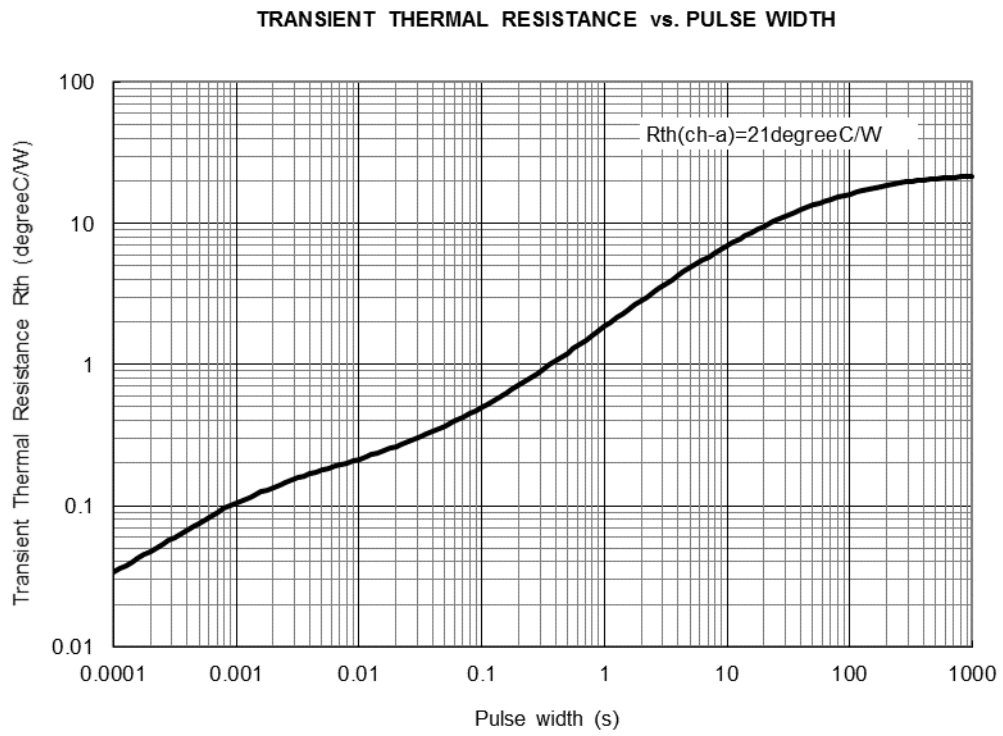

6 Application example in principle

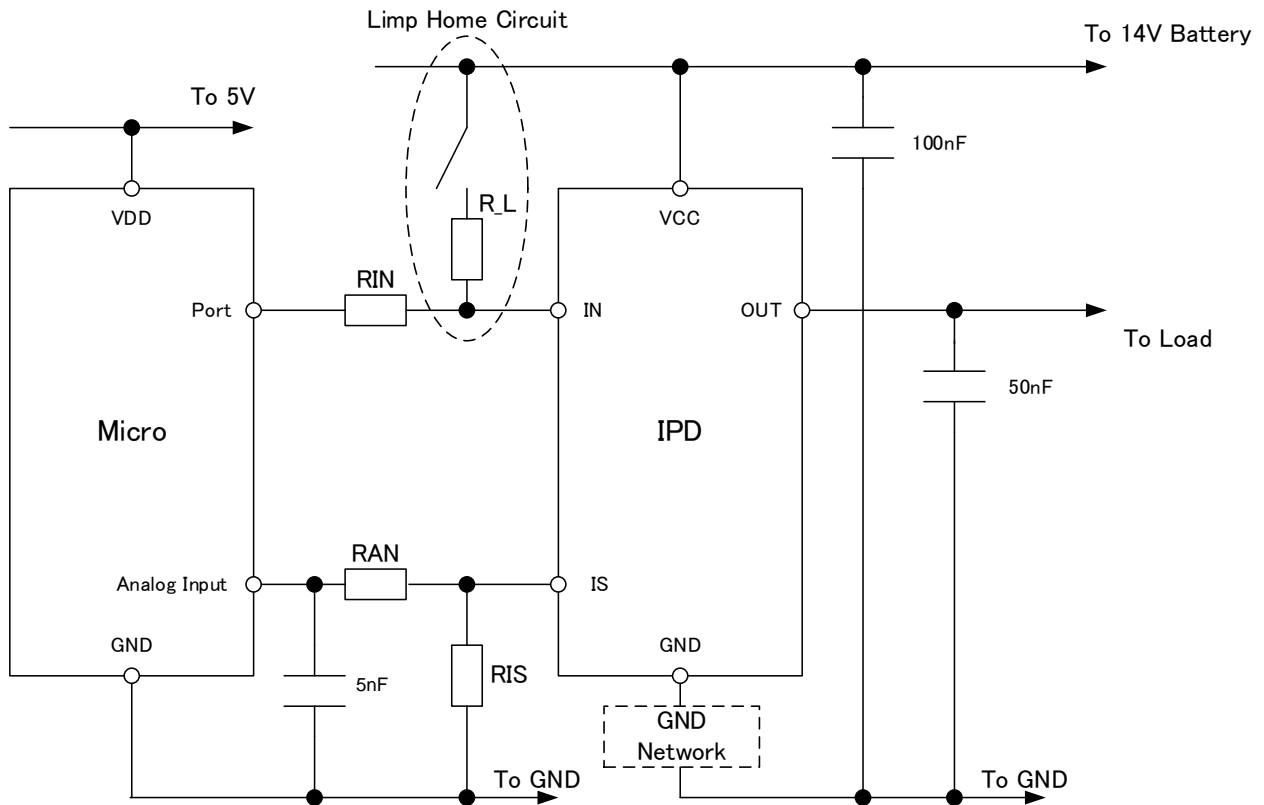

RIN, RAN values are in range of 2k to 50kohm depending microcontroller while R\_L value is typically 4kohm. If necessary to raise HBM tolerated dose, adding resistor between OUT terminal and Ground is effective. Resistor's value is typically 100kohm

GND Network recommendation

In case of  $V_{loaddump} < 35V$

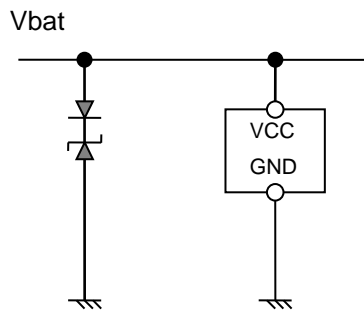

No external component is required.

In case of  $35V < V_{loaddump} < 42V$

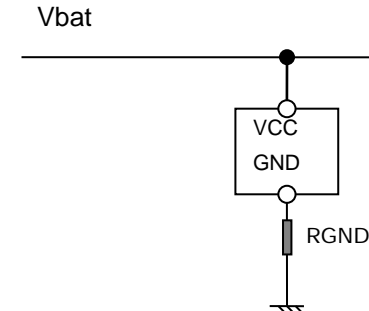

External resistor is recommended in order to limit the current through ZD<sub>AZ</sub> at load dump condition. 100ohm is recommended as RGND.

<b>Revision History</b>	<b>RAJ2800024H12HPF Datasheet</b>
-------------------------	-----------------------------------

Rev.	Date	Description	
		Page	Summary
1.00	Aug. 1, 2017	1-27	1st issue

All documents should contain the following section break and paragraph as the last item. The footers of this document refer to the paragraph in order to reference the last page of the document.

## Notice

1. Descriptions of circuits, software and other related information in this document are provided only to illustrate the operation of semiconductor products and application examples. You are fully responsible for the incorporation or any other use of the circuits, software, and information in the design of your product or system. Renesas Electronics disclaims any and all liability for any losses and damages incurred by you or third parties arising from the use of these circuits, software, or information.
2. Renesas Electronics hereby expressly disclaims any warranties against liability for infringement or any other claims involving patents, copyrights, or other intellectual property rights of third parties, by or arising from the use of Renesas Electronics products or technical information described in this document, including but not limited to, the product data, drawings, charts, programs, algorithms, and application examples.
3. No license, express, implied or otherwise, is granted hereby under any patents, copyrights or other intellectual property rights of Renesas Electronics or others.
4. You shall not alter, modify, copy, or reverse engineer any Renesas Electronics product, whether in whole or in part. Renesas Electronics disclaims any and all liability for any losses or damages incurred by you or third parties arising from such alteration, modification, copying or reverse engineering.
5. Renesas Electronics products are classified according to the following two quality grades: "Standard" and "High Quality". The intended applications for each Renesas Electronics product depends on the product's quality grade, as indicated below.  
"Standard": Computers; office equipment; communications equipment; test and measurement equipment; audio and visual equipment; home electronic appliances; machine tools; personal electronic equipment; industrial robots; etc.  
"High Quality": Transportation equipment (automobiles, trains, ships, etc.); traffic control (traffic lights); large-scale communication equipment; key financial terminal systems; safety control equipment; etc.  
Unless expressly designated as a high reliability product or a product for harsh environments in a Renesas Electronics data sheet or other Renesas Electronics document, Renesas Electronics products are not intended or authorized for use in products or systems that may pose a direct threat to human life or bodily injury (artificial life support devices or systems; surgical implantations; etc.), or may cause serious property damage (space system; undersea repeaters; nuclear power control systems; aircraft control systems; key plant systems; military equipment; etc.). Renesas Electronics disclaims any and all liability for any damages or losses incurred by you or any third parties arising from the use of any Renesas Electronics product that is inconsistent with any Renesas Electronics data sheet, user's manual or other Renesas Electronics document.
6. When using Renesas Electronics products, refer to the latest product information (data sheets, user's manuals, application notes, "General Notes for Handling and Using Semiconductor Devices" in the reliability handbook, etc.), and ensure that usage conditions are within the ranges specified by Renesas Electronics with respect to maximum ratings, operating power supply voltage range, heat dissipation characteristics, installation, etc. Renesas Electronics disclaims any and all liability for any malfunctions, failure or accident arising out of the use of Renesas Electronics products outside of such specified ranges.
7. Although Renesas Electronics endeavors to improve the quality and reliability of Renesas Electronics products, semiconductor products have specific characteristics, such as the occurrence of failure at a certain rate and malfunctions under certain use conditions. Unless designated as a high reliability product or a product for harsh environments in a Renesas Electronics data sheet or other Renesas Electronics document, Renesas Electronics products are not subject to radiation resistance design. You are responsible for implementing safety measures to guard against the possibility of bodily injury, injury or damage caused by fire, and/or danger to the public in the event of a failure or malfunction of Renesas Electronics products, such as safety design for hardware and software, including but not limited to redundancy, fire control and malfunction prevention, appropriate treatment for aging degradation or any other appropriate measures. Because the evaluation of microcomputer software alone is very difficult and impractical, you are responsible for evaluating the safety of the final products or systems manufactured by you.
8. Please contact a Renesas Electronics sales office for details as to environmental matters such as the environmental compatibility of each Renesas Electronics product. You are responsible for carefully and sufficiently investigating applicable laws and regulations that regulate the inclusion or use of controlled substances, including without limitation, the EU RoHS Directive, and using Renesas Electronics products in compliance with all these applicable laws and regulations. Renesas Electronics disclaims any and all liability for damages or losses occurring as a result of your noncompliance with applicable laws and regulations.
9. Renesas Electronics products and technologies shall not be used for or incorporated into any products or systems whose manufacture, use, or sale is prohibited under any applicable domestic or foreign laws or regulations. You shall comply with any applicable export control laws and regulations promulgated and administered by the governments of any countries asserting jurisdiction over the parties or transactions.
10. It is the responsibility of the buyer or distributor of Renesas Electronics products, or any other party who distributes, disposes of, or otherwise sells or transfers the product to a third party, to notify such third party in advance of the contents and conditions set forth in this document.
11. This document shall not be reprinted, reproduced or duplicated in any form, in whole or in part, without prior written consent of Renesas Electronics.
12. Please contact a Renesas Electronics sales office if you have any questions regarding the information contained in this document or Renesas Electronics products.  
(Note 1) "Renesas Electronics" as used in this document means Renesas Electronics Corporation and also includes its directly or indirectly controlled subsidiaries.  
(Note 2) "Renesas Electronics product(s)" means any product developed or manufactured by or for Renesas Electronics.

(Rev.4.0-1 November 2017)



### SALES OFFICES

Renesas Electronics Corporation

<http://www.renesas.com>

Refer to "<http://www.renesas.com/>" for the latest and detailed information.

#### Renesas Electronics America Inc.

1001 Murphy Ranch Road, Milpitas, CA 95035, U.S.A.  
Tel: +1-408-432-8888, Fax: +1-408-434-5351

#### Renesas Electronics Canada Limited

9251 Yonge Street, Suite 8309 Richmond Hill, Ontario Canada L4C 9T3  
Tel: +1-905-237-2004

#### Renesas Electronics Europe Limited

Dukes Meadow, Millboard Road, Bourne End, Buckinghamshire, SL8 5FH, U.K  
Tel: +44-1628-651-700, Fax: +44-1628-651-804

#### Renesas Electronics Europe GmbH

Arcadiastrasse 10, 40472 Düsseldorf, Germany  
Tel: +49-211-6503-0, Fax: +49-211-6503-1327

#### Renesas Electronics (China) Co., Ltd.

Room 1709 Quantum Plaza, No.27 ZhichunLu, Haidian District, Beijing, 100191 P. R. China  
Tel: +86-10-8235-1155, Fax: +86-10-8235-7679

#### Renesas Electronics (Shanghai) Co., Ltd.

Unit 301, Tower A, Central Towers, 555 Langao Road, Putuo District, Shanghai, 200333 P. R. China  
Tel: +86-21-2226-0888, Fax: +86-21-2226-0999

#### Renesas Electronics Hong Kong Limited

Unit 1601-1611, 16/F., Tower 2, Grand Century Place, 193 Prince Edward Road West, Mongkok, Kowloon, Hong Kong  
Tel: +852-2265-6688, Fax: +852 2886-9022

#### Renesas Electronics Taiwan Co., Ltd.

13F, No. 363, Fu Shing North Road, Taipei 10543, Taiwan  
Tel: +886-2-8175-9600, Fax: +886 2-8175-9670

#### Renesas Electronics Singapore Pte. Ltd.

80 Bendemeer Road, Unit #06-02 Hyflux Innovation Centre, Singapore 339949  
Tel: +65-6213-0200, Fax: +65-6213-0300

#### Renesas Electronics Malaysia Sdn.Bhd.

Unit 1207, Block B, Menara Amcorp, Amcorp Trade Centre, No. 18, Jln Persiaran Barat, 46050 Petaling Jaya, Selangor Darul Ehsan, Malaysia  
Tel: +60-3-7955-9390, Fax: +60-3-7955-9510

#### Renesas Electronics India Pvt. Ltd.

No.777C, 100 Feet Road, HAL 2nd Stage, Indiranagar, Bangalore 560 038, India  
Tel: +91-80-67208700, Fax: +91-80-67208777

#### Renesas Electronics Korea Co., Ltd.

17F, KAMCO Yangjae Tower, 262, Gangnam-daero, Gangnam-gu, Seoul, 06265 Korea  
Tel: +82-2-558-3737, Fax: +82-2-558-5338