RAA2900014H12HPD

R07DS1266EJ0101

Rev.1.01

INTELLIGENT POWER DEVICE

Feb. 28, 2020

1. Overview

1.1 Description

RAA290001 is designed for 2 Wheeler Flasher driver with double frequency flashing in low load current condition.

1.2 Features

- High side driver
- Low on-state resistance
- Small package; TO252-3
- Short circuit protection
 - Over temperature protection with current limitation control
- Built-in auto flashing operation with only one external capacitor
- Built-in double frequency flashing in low load condition
- Active clamp operation at inductive load switch off
- RoHS compliant

1.3 Application

- 2 Wheeler Flasher bulb switching

2. Ordering Information

Part No.	Lead plating	Packing	Package
RAA2900014H12HPD	Pure Sn	Tape 2500pcs /reel	TO252 (MP-3ZP)

3. Specification

3.1 Block Diagram

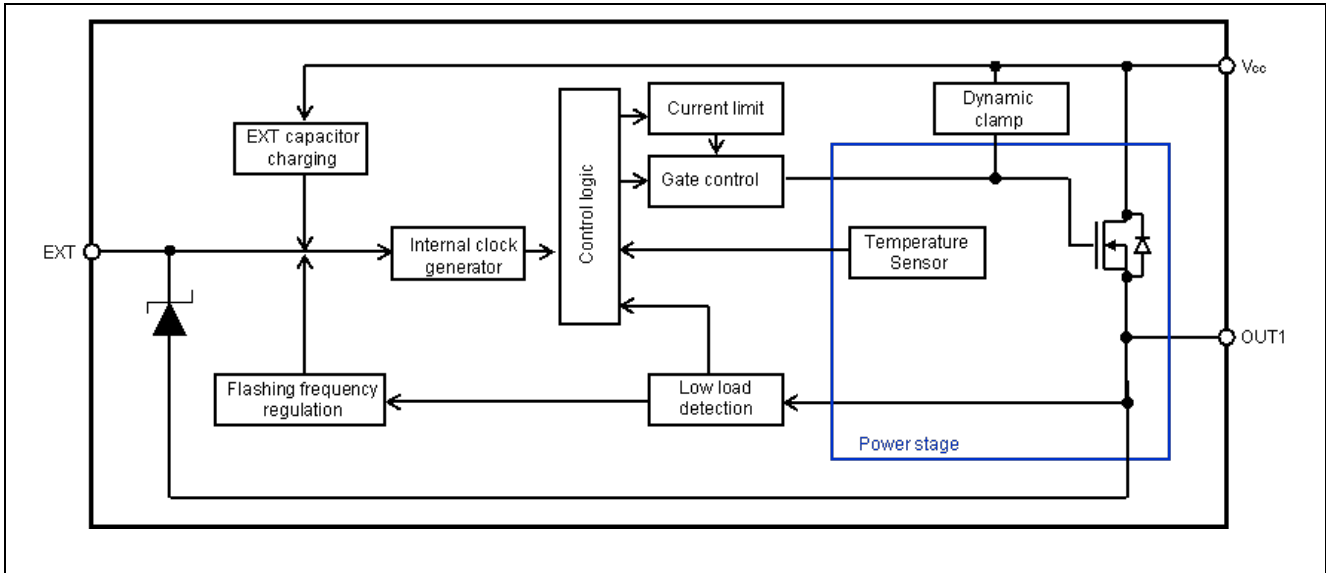

3.2 Current and Voltage definition

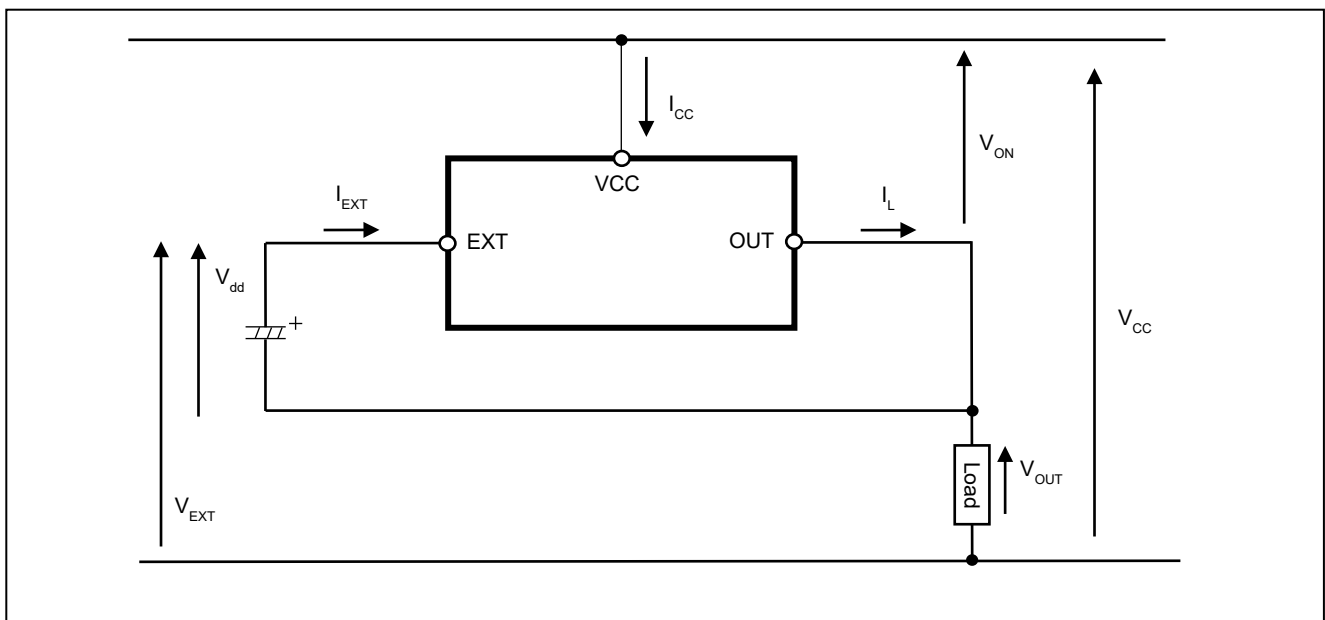

3.3 Pin Configuration

Pin No.	Terminal Name
1	EXT
2/4	VCC
3	OUT



Pin function

Terminal Name	Pin function	Recommended connection
EXT	An external capacitor is connected between EXT pin and OUT pin. This capacitor stores power supply to the device during on-state and sets the flashing frequency.	Connected to OUT pin with 220uF capacitor
VCC	Positive power supply for logic supply as well as output power supply	
OUT	Protected high-side power output channel	

3.4 Absolute Maximum Ratings

Ta=25degreeC, unless other specified

Parameter	Symbol	Rating	Unit	Test Condition		
Vcc Voltage	V _{CC}	28	V			
Vcc Voltage at reverse battery condition	-V _{CC}	-16	V	RL=Nomimal load, Refer 3.8.4, t<2min		
Output Drain to Source Voltage	V _{DSS}	42	V	RL=Nomimal load, Refer 3.8.4, t = 200 ms		
Load Current	I _L	Self limited	A			
OUT Reverse Current at reverse battery condition	-I _L	-5	A	t<2min		
Total power dissipation for whole device (DC)	P _D	1.8	W	Ta=85degreeC, Device on 50mmx50mmx1.5mm epoxy PCB FR4 with 6 cm2 of 70 um copper area		
Voltage between EXT and OUT	V _{dd}	6.5	V			
Channel Temperature	T _{ch}	-40 to +150	degreeC			
Storage Temperature	T _{stg}	-55 to +150	degreeC			
ESD susceptibility	V _{ESD}	2000	V	HBM	AEC-Q100-002 std. R=1.5kohm, C=100pF	All pin
		4000			IEC61000-4-2 std. R=330ohm, C=150pF, 100nF at VCC and OUT	VCC, OUT
		200	V	MM	AEC-Q100-003 std. R=0ohm, C=200pF	

3.5 Recommended Operation Condition

Parameter	Symbol	Min	Typ	Max	Unit	Test Condition
Ambient temperature	Ta	-20		85	degreeC	
Power supply voltage	V _{CC}	9		16	V	

3.6 Thermal Characteristics

Parameter	Symbol	Min	Typ	Max	Unit	Test Condition
Thermal characteristics	R _{th(ch-a)}		40		degree C/W	According to JEDEC JESD51-2, -5, -7 on FR4 2s2p board
	R _{th(ch-c)}		5		degree C/W	

3.7 Electrical Characteristics

Operation function

Tch=-40 to 150degreeC, Vcc=9 to 16V, 220uF between EXT and OUT, unless otherwise specified

Parameter	Symbol	Min	Typ	Max	Unit	Test Condition	
Operating Voltage	V _{CC}	9		28	V	Von<0.4V, RL=Nomimal load, Refer 3.8.4	
		7.0		9.0	V	Auto flashing operation RL=Nomimal load, Refer 3.8.4	
On-state resistance	Ron		40		mohm	Tch=25°C	
				100		Tch=150°C	RL=Nominal load, Refer 3.8.4
Slew rate on	dV/dton	0.04		1.0	V/μs	VCC=13.5V, RL=Nominal load, Refer 3.8.4, Refer 3.8.5	
Slew rate off	-dV/dtoff	0.04		1.0	V/μs		
Turn on delay time after power supply on 1)	td(on)			100	ms	VCC=13.5V, Tch=-20 to 85°C, RL=Nominal load, , Refer 3.8.4, Refer 3.8.5	
Nominal operation frequency	fnom	1.25	1.4	1.58	Hz	Vcc=13.5V	
		0.66				Vcc=7.0 to 9V	Tch=25°C, RL=Nominal load, Refer 3.8.4
		1.12	1.4	1.68		Vcc=9 to 16V	Tch=-20 to 85°C, RL=Nominal load, Refer 3.8.4
On duty rate	don	35		60	%	Tch=-20 to 85°C, RL=Nominal load, Refer 3.8.4	
Internal clock high level between EXT and OUT	Vexth		6.10		V	VCC=13.5V	
Internal clock low level between EXT and OUT	Vextl		4.95		V	VCC=13.5V	
EXT clamp voltage	Vdd,clamp		7		V	IEXT=2mA, Von=0V	
EXT reverse clamp voltage	Vdd,rev		-0.7		V	IEXT=-2mA, Von=0V	
Supply current via EXT pin	IEXT		708		μA	Von=0V, Vext=5.5V, Tch=25°C	
Double frequency flashing threshold	ldff	0.85	0.96	1.06	A	VCC=9V, Tch=-20 to 85°C	
		1.07	1.20	1.33		VCC=13.5V, Tch=-20 to 85°C	
		1.20	1.34	1.47		VCC=16V, Tch=-20 to 85°C	

1) not subjected production test, guaranteed by design

Protection function

Tch=-40 to 150degreeC, Vcc=9 to 16V, unless other wise specified

Parameter	Symbol	Min	Typ	Max	Unit	Test Condition
Current limitation	IL(LIM)		14		A	VCC=13.5V
Absolute thermal shutdown temperature	aTth	150			degreeC	

3.8 Feature Description

3.8.1 Normal operation

When a nominal load such as defined 3.8.4 is connected to OUT pin, device operate with auto flashing mode by charging EXT capacitor up to the V_{extH} quickly, and then discharging EXT capacitor down to V_{extL} slowly with constant current IEXT.

Auto flashing operation frequency is determined following formula. Duty cycle is approx. 50%.

$$f_{nom} = \frac{I_{EXT}}{2 \times C_{EXT} \times (V_{extH} - V_{extL})}$$

3.8.2 Double flashing operation at low load current condition

If load current is lower than I_{dfl} during on-state, device detects low load condition, and start double flashing operation automatically.

3.8.3 Short circuit protection

The device shuts down automatically when $T_{ch} > aT_{th}$ is detected.

Absolute thermal toggling

Current limitation control with IL(LIM) when auto restart from absolute T_{ch} protection.

3.8.4 Nominal load

Product	Nominal load
RAA290001	8.0ohm

3.8.5 Measurement condition

Switching waveform of OUT terminal

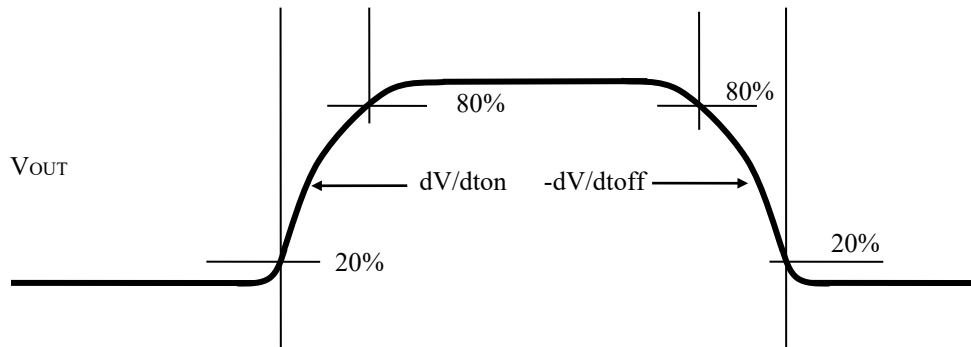

Turn on delay time after Power Supply on

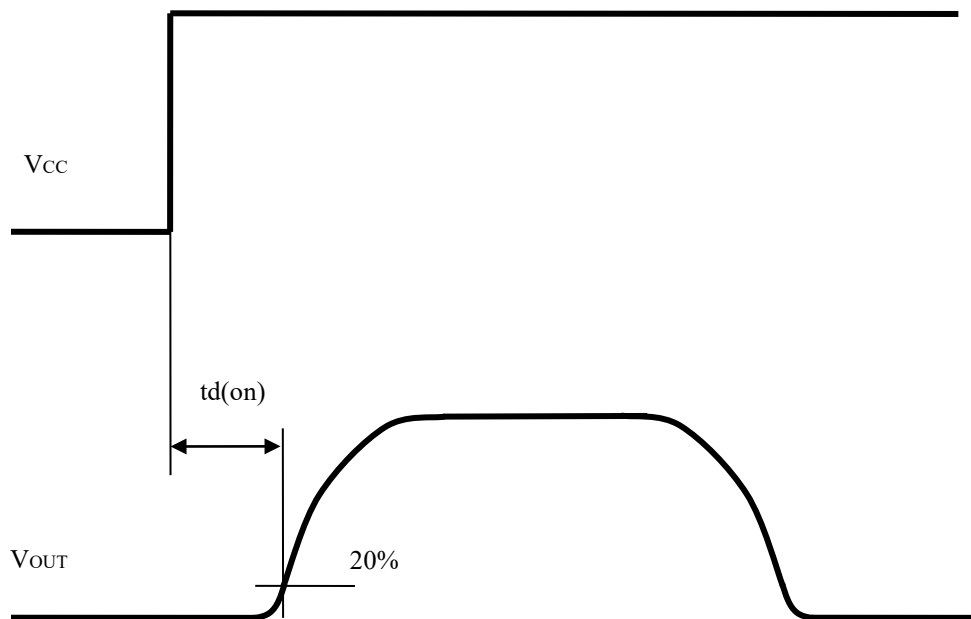

3.8.6 Timing chart

Nominal Operation

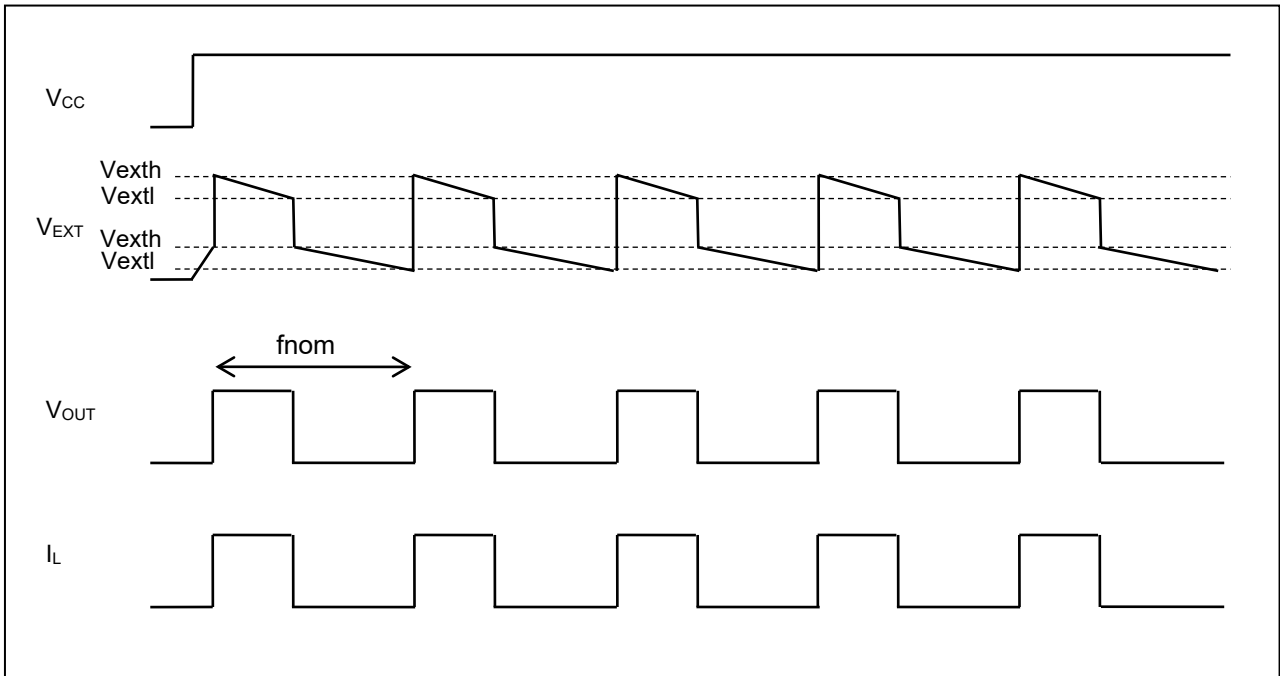

Double flashing operation at low load current condition

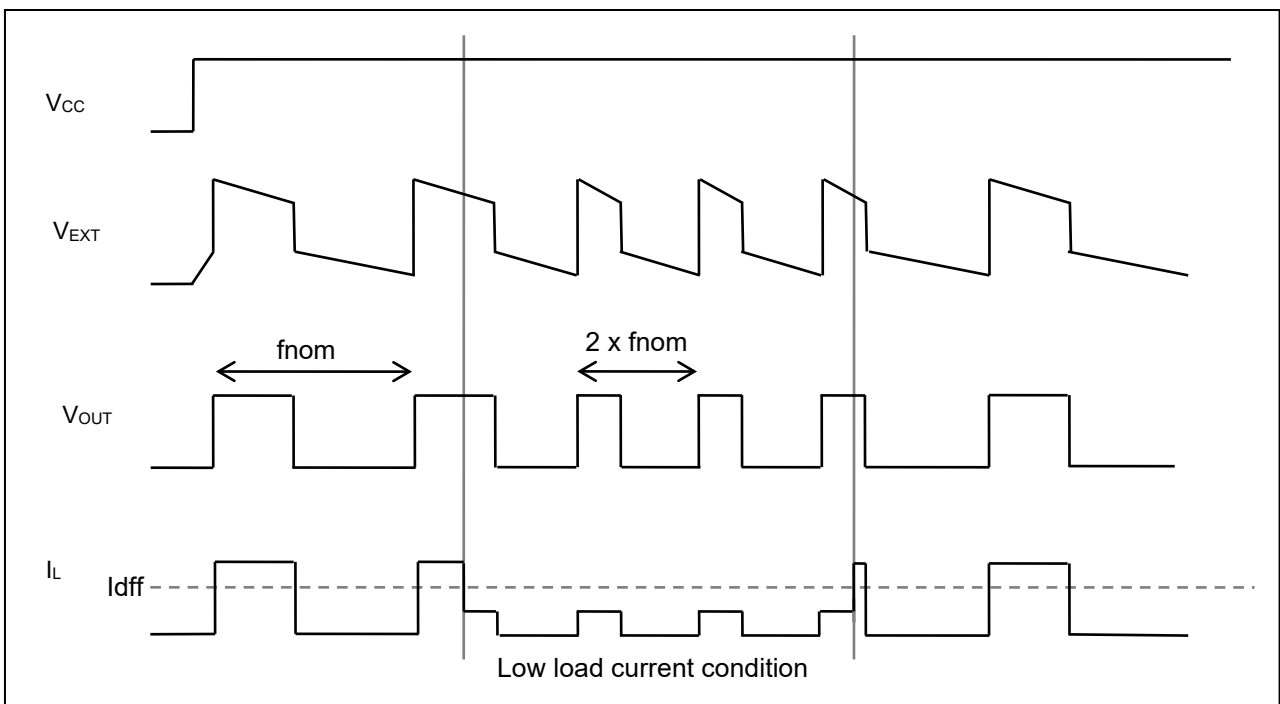

Short circuit protection

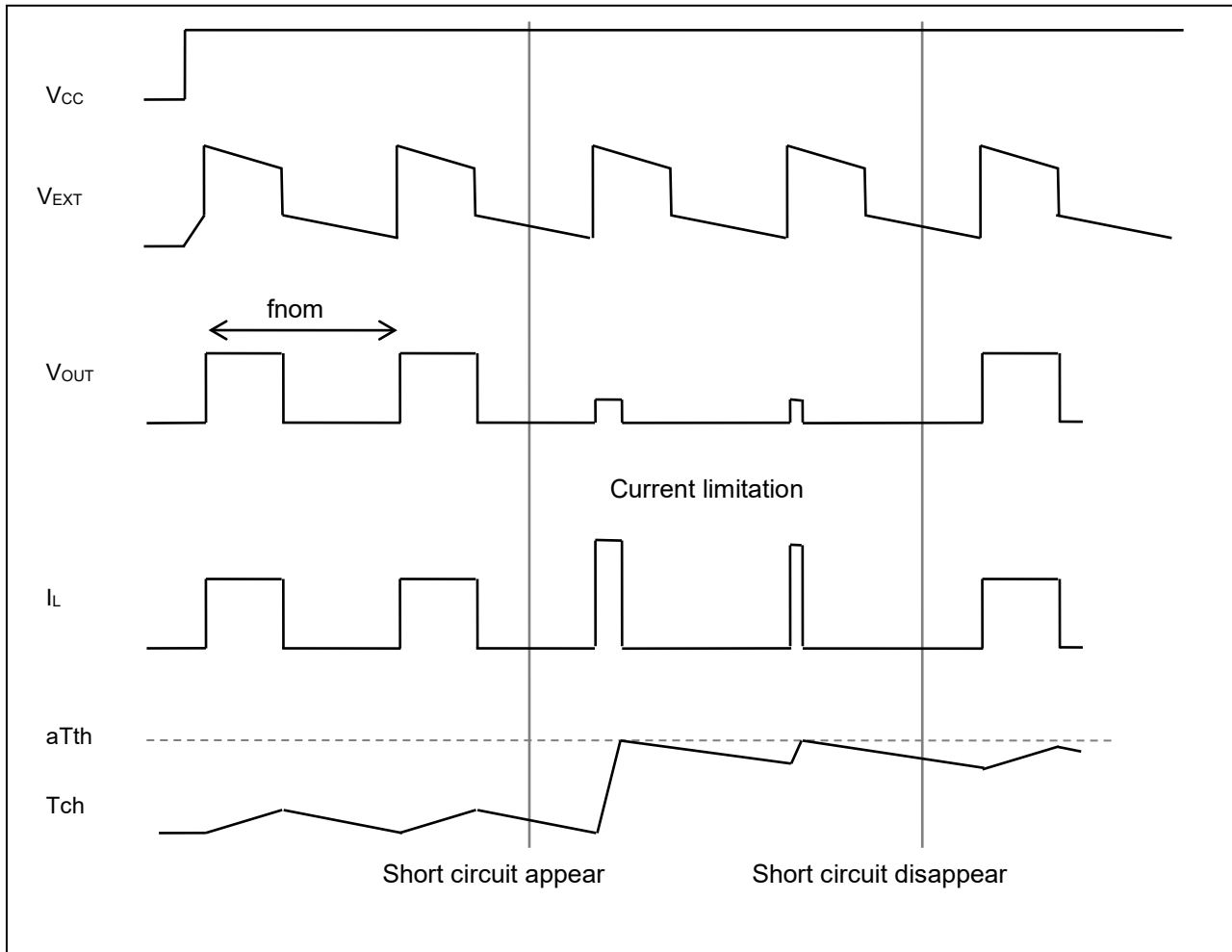

3.9 Package drawing

JEITA Package Code	Renesas Code	Previous Code	Mass(TYP.)[g]
-	PRSS0004ZP-A	P3J5-230-512	0.3

Unit : mm

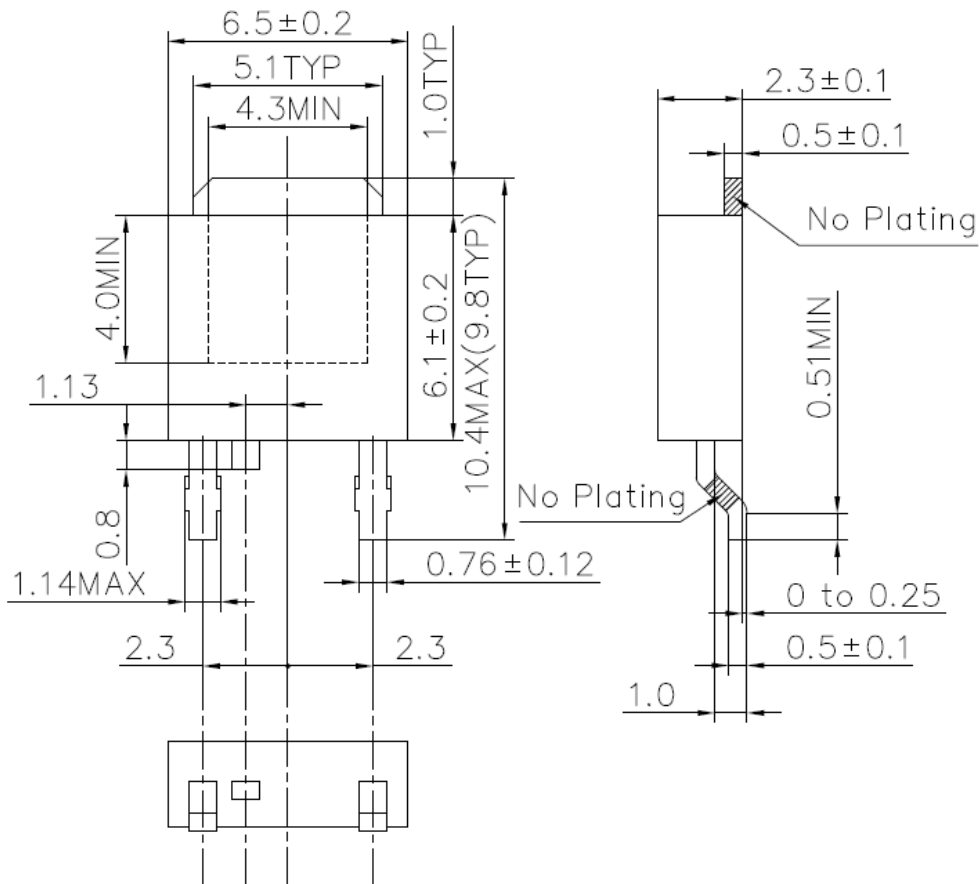

3.10 Taping information

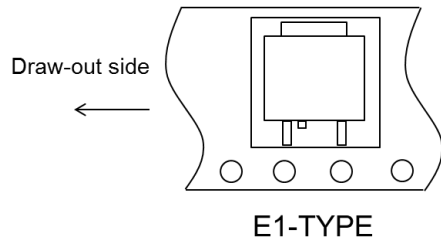

3.11 Marking information

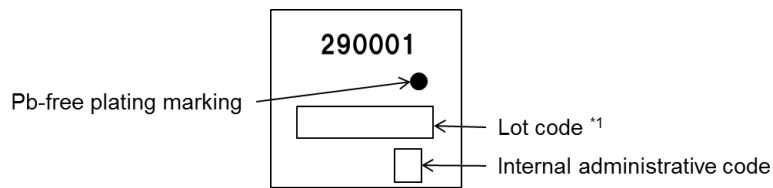

Note: *1. Composition of the lot code

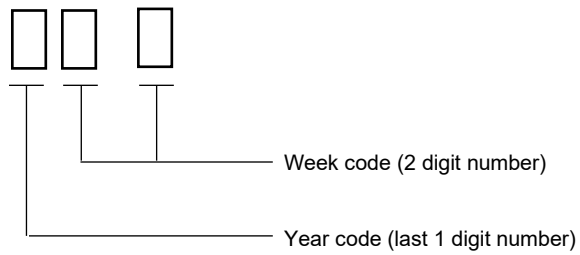

4. Typical characteristics

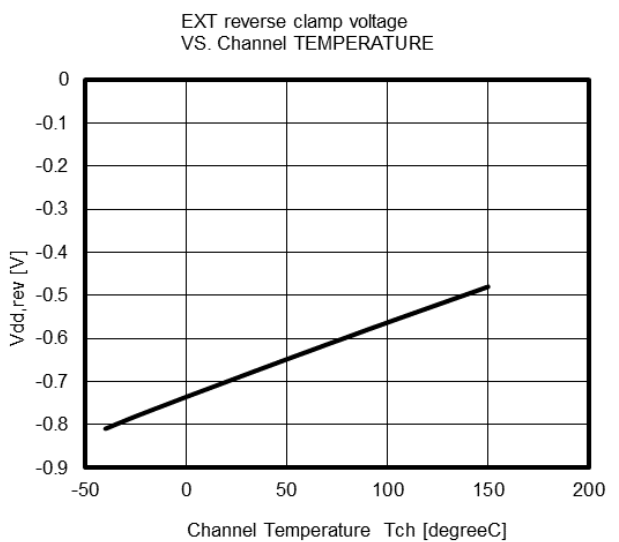
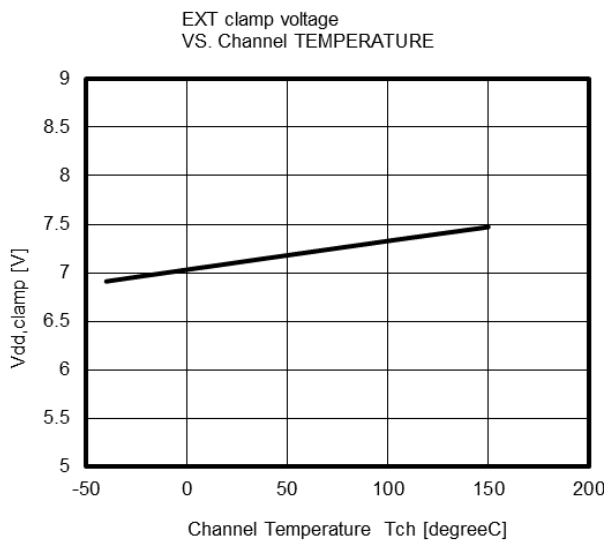
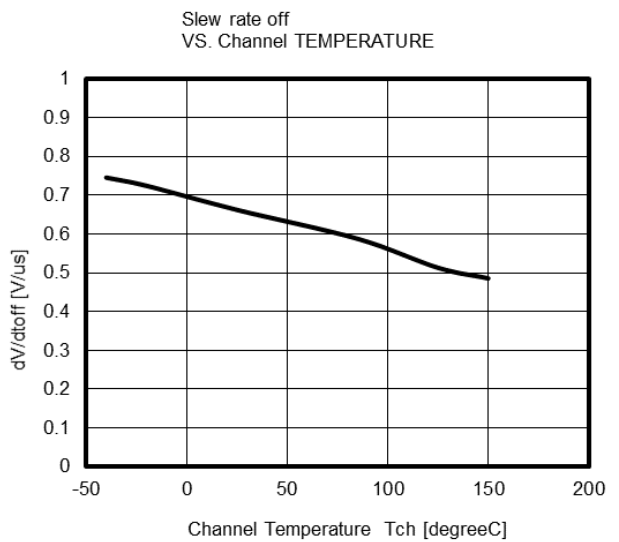
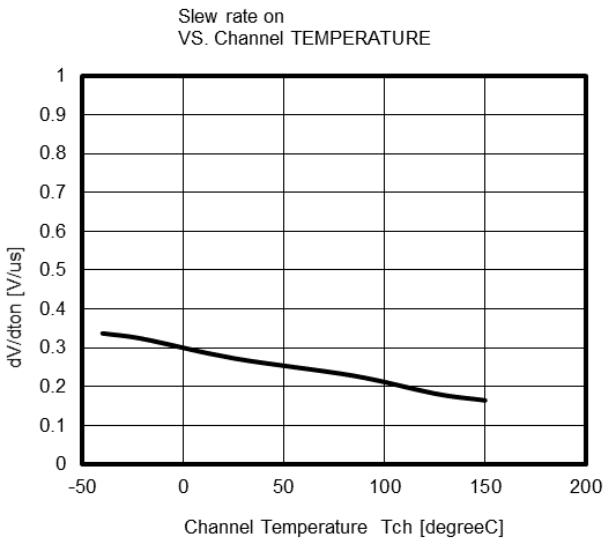
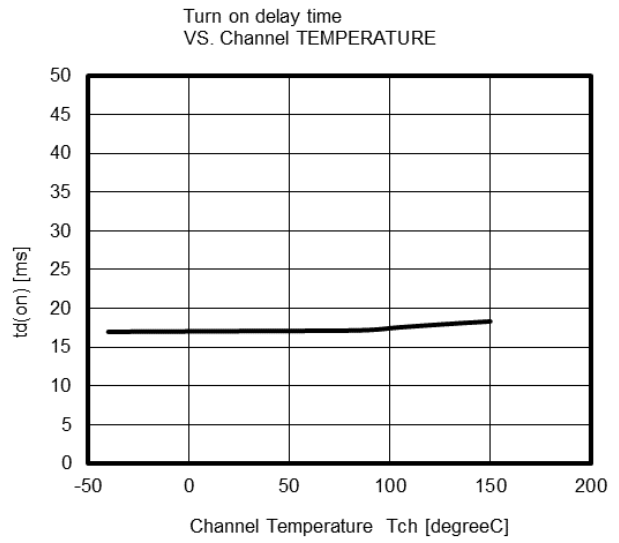
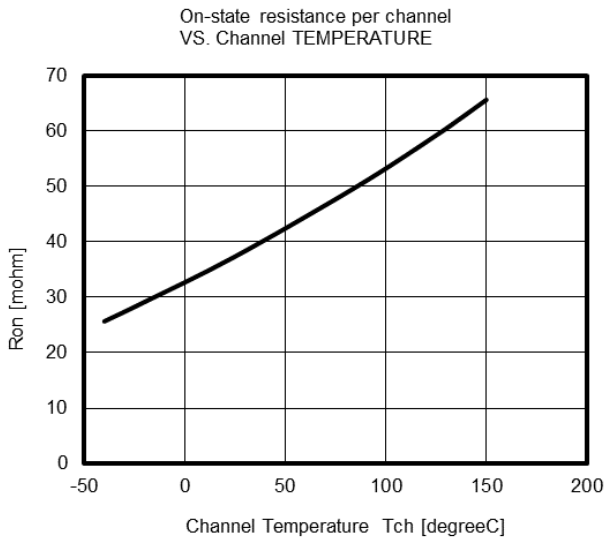

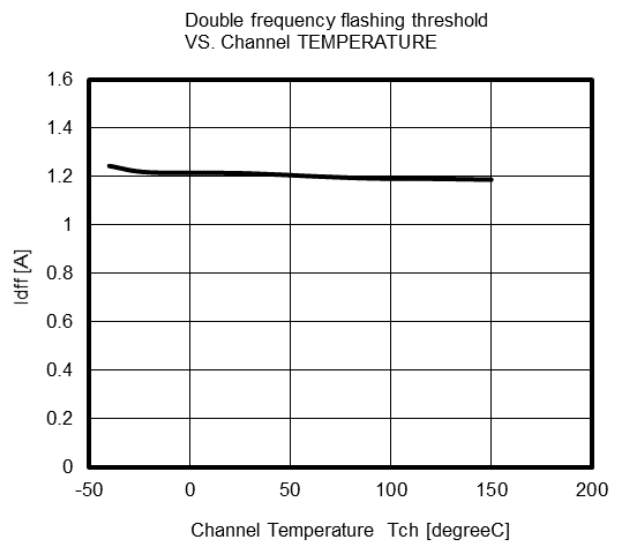
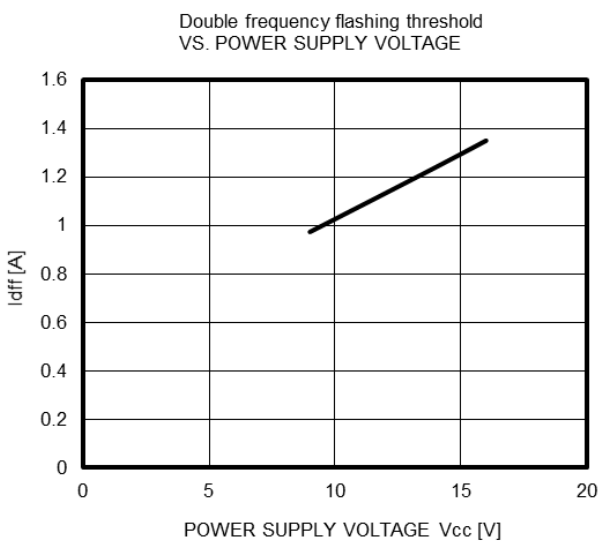
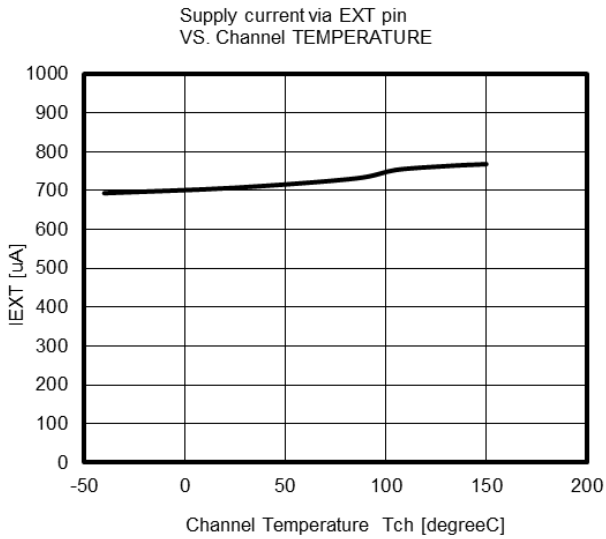
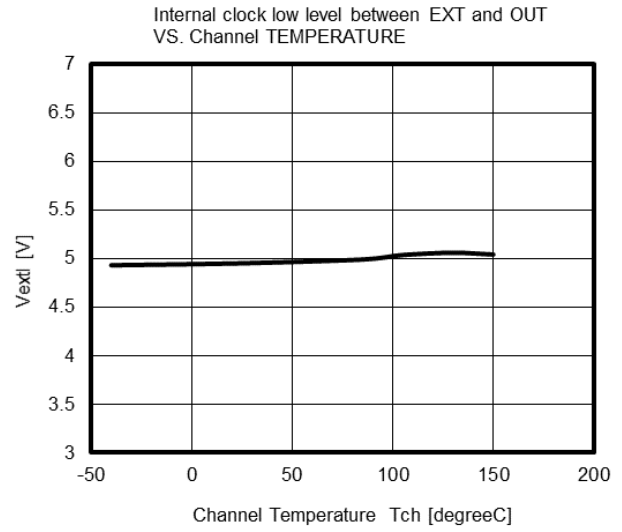
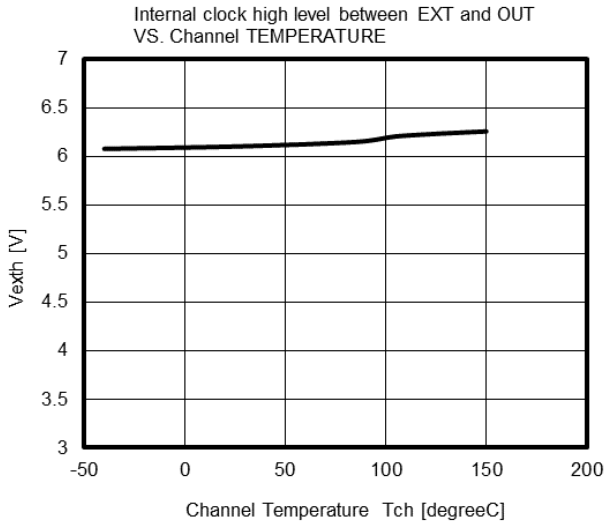

Nominal operation frequency
VS. POWER SUPPLY VOLTAGE

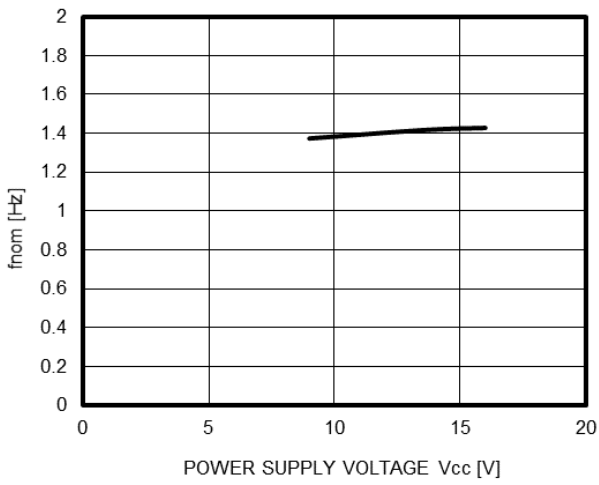

Nominal operation frequency
VS. Channel TEMPERATURE

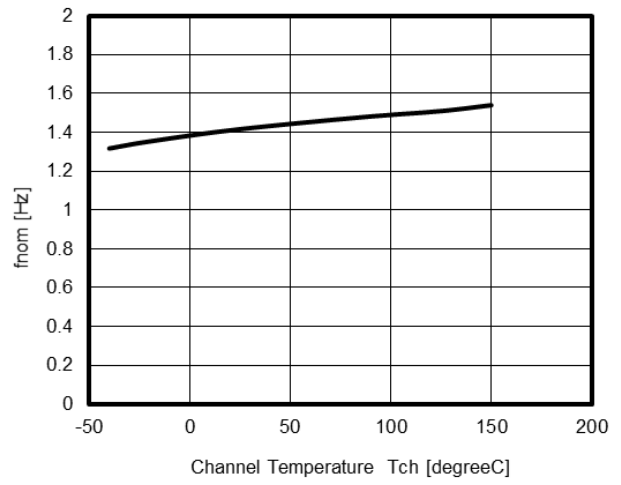

Current limitation
VS. Channel TEMPERATURE

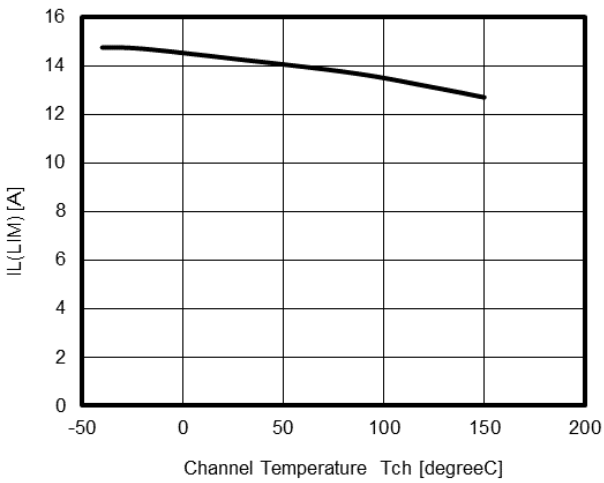

5. Thermal characteristics

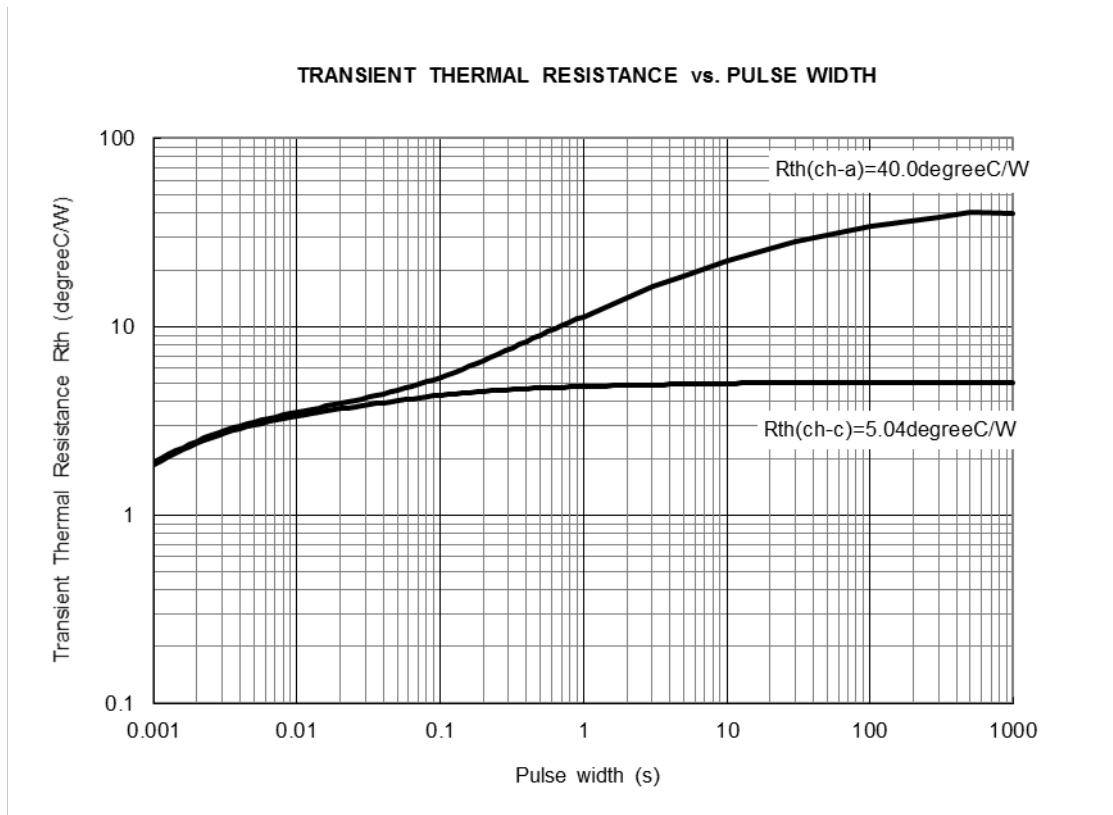

6. Application example in principle

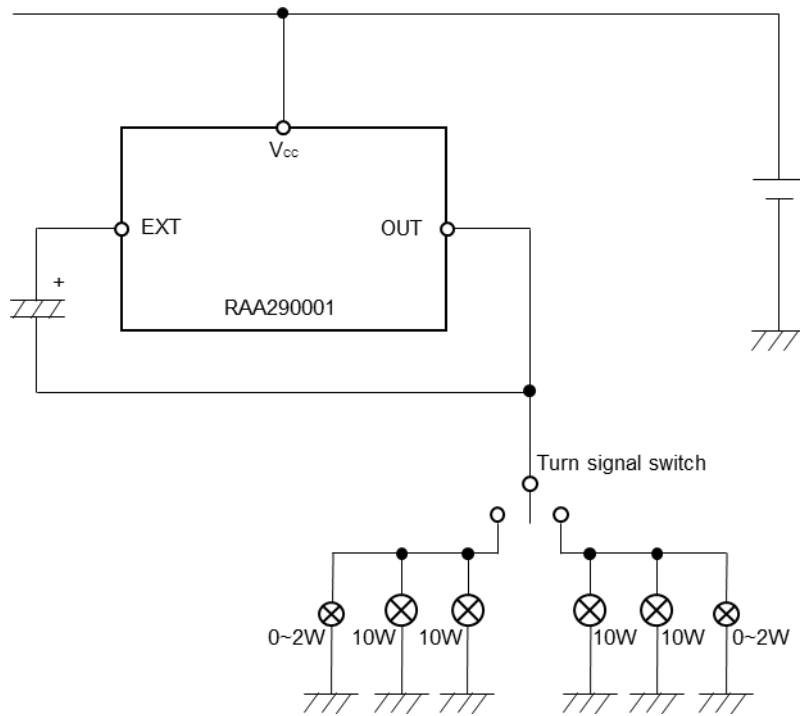

Recommended circuit for dump surge

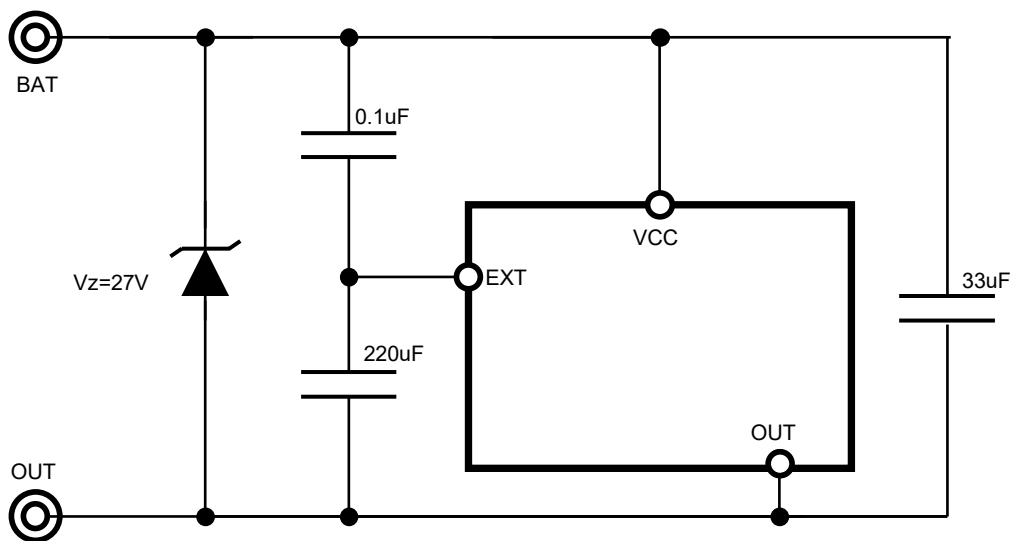

Revision History	RAA290001 Datasheet
-------------------------	----------------------------

Rev.	Date	Description	
		Page	Summary
1.00	Jun. 17, 2015	1-17	1st issue
1.01	Feb. 28, 2020	1	Deleted description of "AEC-Q100 qualified" Deleted description of "Note: The information contained in this document is the one that was obtained when the document was issued, and may be subject to change."

All documents should contain the following section break and paragraph as the last item. The footers of this document refer to the paragraph in order to reference the last page of the document.

Notice

1. Descriptions of circuits, software and other related information in this document are provided only to illustrate the operation of semiconductor products and application examples. You are fully responsible for the incorporation or any other use of the circuits, software, and information in the design of your product or system. Renesas Electronics disclaims any and all liability for any losses and damages incurred by you or third parties arising from the use of these circuits, software, or information.
 2. Renesas Electronics hereby expressly disclaims any warranties against and liability for infringement or any other claims involving patents, copyrights, or other intellectual property rights of third parties, by or arising from the use of Renesas Electronics products or technical information described in this document, including but not limited to, the product data, drawings, charts, programs, algorithms, and application examples.
 3. No license, express, implied or otherwise, is granted hereby under any patents, copyrights or other intellectual property rights of Renesas Electronics or others.
 4. You shall not alter, modify, copy, or reverse engineer any Renesas Electronics product, whether in whole or in part. Renesas Electronics disclaims any and all liability for any losses or damages incurred by you or third parties arising from such alteration, modification, copying or reverse engineering.
 5. Renesas Electronics products are classified according to the following two quality grades: "Standard" and "High Quality". The intended applications for each Renesas Electronics product depends on the product's quality grade, as indicated below.
 - "Standard": Computers; office equipment; communications equipment; test and measurement equipment; audio and visual equipment; home electronic appliances; machine tools; personal electronic equipment; industrial robots; etc.
 - "High Quality": Transportation equipment (automobiles, trains, ships, etc.); traffic control (traffic lights); large-scale communication equipment; key financial terminal systems; safety control equipment; etc.
- Unless expressly designated as a high reliability product or a product for harsh environments in a Renesas Electronics data sheet or other Renesas Electronics document, Renesas Electronics products are not intended or authorized for use in products or systems that may pose a direct threat to human life or bodily injury (artificial life support devices or systems; surgical implantations; etc.), or may cause serious property damage (space system; undersea repeaters; nuclear power control systems; aircraft control systems; key plant systems; military equipment; etc.). Renesas Electronics disclaims any and all liability for any damages or losses incurred by you or any third parties arising from the use of any Renesas Electronics product that is inconsistent with any Renesas Electronics data sheet, user's manual or other Renesas Electronics document.
6. When using Renesas Electronics products, refer to the latest product information (data sheets, user's manuals, application notes, "General Notes for Handling and Using Semiconductor Devices" in the reliability handbook, etc.), and ensure that usage conditions are within the ranges specified by Renesas Electronics with respect to maximum ratings, operating power supply voltage range, heat dissipation characteristics, installation, etc. Renesas Electronics disclaims any and all liability for any malfunctions, failure or accident arising out of the use of Renesas Electronics products outside of such specified ranges.
 7. Although Renesas Electronics endeavors to improve the quality and reliability of Renesas Electronics products, semiconductor products have specific characteristics, such as the occurrence of failure at a certain rate and malfunctions under certain use conditions. Unless designated as a high reliability product or a product for harsh environments in a Renesas Electronics data sheet or other Renesas Electronics document, Renesas Electronics products are not subject to radiation resistance design. You are responsible for implementing safety measures to guard against the possibility of bodily injury, injury or damage caused by fire, and/or danger to the public in the event of a failure or malfunction of Renesas Electronics products, such as safety design for hardware and software, including but not limited to redundancy, fire control and malfunction prevention, appropriate treatment for aging degradation or any other appropriate measures. Because the evaluation of microcomputer software alone is very difficult and impractical, you are responsible for evaluating the safety of the final products or systems manufactured by you.
 8. Please contact a Renesas Electronics sales office for details as to environmental matters such as the environmental compatibility of each Renesas Electronics product. You are responsible for carefully and sufficiently investigating applicable laws and regulations that regulate the inclusion or use of controlled substances, including without limitation, the EU RoHS Directive, and using Renesas Electronics products in compliance with all these applicable laws and regulations. Renesas Electronics disclaims any and all liability for damages or losses occurring as a result of your noncompliance with applicable laws and regulations.
 9. Renesas Electronics products and technologies shall not be used for or incorporated into any products or systems whose manufacture, use, or sale is prohibited under any applicable domestic or foreign laws or regulations. You shall comply with any applicable export control laws and regulations promulgated and administered by the governments of any countries asserting jurisdiction over the parties or transactions.
 10. It is the responsibility of the buyer or distributor of Renesas Electronics products, or any other party who distributes, disposes of, or otherwise sells or transfers the product to a third party, to notify such third party in advance of the contents and conditions set forth in this document.
 11. This document shall not be reprinted, reproduced or duplicated in any form, in whole or in part, without prior written consent of Renesas Electronics.
 12. Please contact a Renesas Electronics sales office if you have any questions regarding the information contained in this document or Renesas Electronics products.

(Note1) "Renesas Electronics" as used in this document means Renesas Electronics Corporation and also includes its directly or indirectly controlled subsidiaries.

(Note2) "Renesas Electronics product(s)" means any product developed or manufactured by or for Renesas Electronics.

(Rev.4.0-1 November 2017)

Corporate Headquarters

TOYOSU FORESIA, 3-2-24 Toyosu,
Koto-ku, Tokyo 135-0061, Japan
www.renesas.com

Trademarks

Renesas and the Renesas logo are trademarks of Renesas Electronics Corporation. All trademarks and registered trademarks are the property of their respective owners.

Contact Information

For further information on a product, technology, the most up-to-date version of a document, or your nearest sales office, please visit:
www.renesas.com/contact/