

Description

The MK2745-21 is a low-cost, low-jitter, high-performance clock synthesizer for DVD and other MPEG 2-based applications. Using analog Phase-Locked Loop (PLL) techniques, the device accepts a 27 MHz fundamental mode crystal or clock input to produce multiple audio output clocks, a processor clock, the processor clock divided by two, 27 MHz, 24.576 MHz, and a selectable audio clock. The audio clocks are frequency-locked to the 27 MHz using our patented zero ppm error techniques. This allows audio and video to track exactly, thereby eliminating the need for large buffer memory.

IDT manufactures a large variety of DVD, Set-top Box, and multimedia clock synthesizers for all applications. Consult IDT to eliminate crystals and oscillators from your board.

Features

- Packaged in a 16-pin narrow (150 mil) SOIC
- Ideal for LuxSonor's DVD solutions
- 3.3 V upgrade to the MK2744
- Patented zero ppm audio clock error for 256x and 384x sampling rates
- Selectable audio sampling frequencies support 32, 44.1, and 48 kHz in most DACs
- 27 MHz fundamental crystal or clock input
- Eight selectable processor frequencies
- Fixed clocks of 27 and 24.576 MHz
- Zero ppm in all clocks
- 25 mA output drive capability at TTL levels
- Advanced, low-power, sub-micron CMOS process
- Operating voltage of 3.0 V to 5.5 V
- See also the MK2712 for NTSC/PAL clocks

Block Diagram

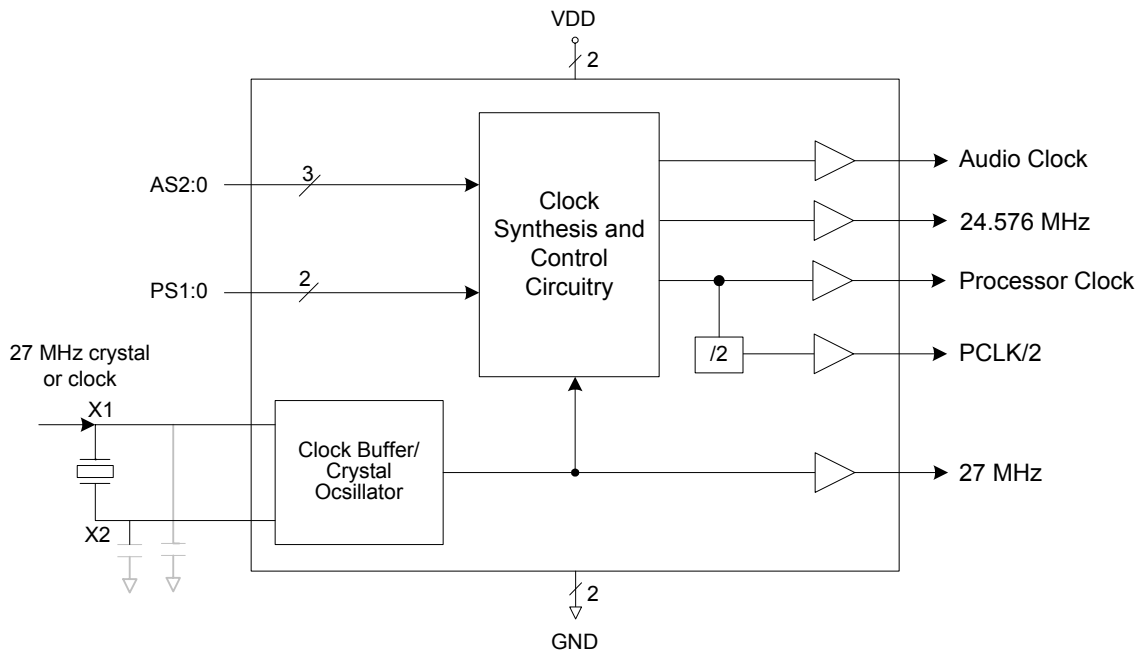

Pin Assignment

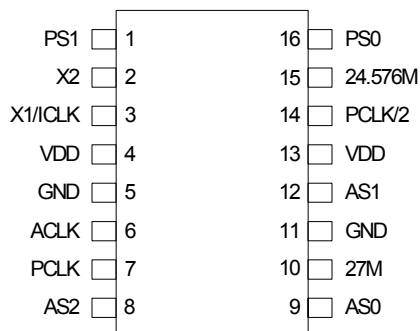

16-pin (150 mil) SOIC

Audio Clock (MHz) Decoding Table

AS2	AS1	AS0	ACLK
0	0	0	12.288
0	0	1	11.2896
0	1	0	8.192
0	1	1	24.576
1	0	0	8.192
1	0	1	16.9344
1	1	0	18.432
1	1	1	11.2896

Processor Clock (MHz)

PS1	PS0	PCLK	PCLK/2
0	0	66.66	33.33
0	1	80	40
1	0	50	25
1	1	60	30

0 = connect directly to ground

1 = connect directly to VDD

Pin Descriptions

Pin Number	Pin Name	Pin Type	Pin Description
1	PS1	Input	Processor clock Select 1. Selects processor clock outputs per table above.
2	X2	XO	Crystal connection. Connect to 27 MHz crystal. Leave unconnected for clock input.
3	X1/CLK	XI	Crystal connection. Connect to 27 MHz crystal or to a 27 MHz input clock.
4	VDD	Power	Connect to +3.3 V or +5 V. Must be same as other VDD.
5	GND	Power	Connect to ground.
6	ACLK	Output	Audio Clock output. Determined by status of AS2, AS1, AS0. See table above.
7	PCLK	Output	Processor Clock output. Determined by status of PS1, PS0. See table above.
8	AS2	Input	Audio clock Select 2. Selects audio clock on pin 6 per table above.
9	AS0	Input	Audio clock Select 0. Selects audio clock on pin 6 per table above.
10	27M	Output	27 MHz clock output.
11	GND	Power	Connect to ground.
12	AS1	Input	Audio clock Select 1. Selects audio clock on pin 6 per table above.
13	VDD	Power	Connect to +3.3 V or +5 V. Must be same as other VDD.

Pin Number	Pin Name	Pin Type	Pin Description
14	PCLK/2	Output	Processor Clock divided by two output. Determined by status of PS1, PS0. See table above.
15	24.576M	Output	24.576 MHz clock output.
16	PS0	Input	Processor clock Select 0. Selects processor clock outputs per table above.

External Components

The MK2745-21 requires a minimum number of external components for proper operation. Decoupling capacitors of 0.1 μ F should be connected between VDD and GND, as close to the MK2745-21 as possible. A series termination resistor of 33 Ω may be used for each clock output. If a clock input is not used, the 27 MHz crystal must be connected as close to the chip as possible. The crystal should be a fundamental mode (do not use third overtone), parallel resonant, 50 ppm or better. Crystal capacitors should be connected from pins X1 to ground and X2 to ground. The value of these capacitors is given by the following equation, where CL is the crystal load capacitance: Crystal caps (pF) = (CL-6) x 2. So, for a crystal with 16 pF load capacitance, two 20 pF caps should be used.

Absolute Maximum Ratings

Stresses above the ratings listed below can cause permanent damage to the MK2745-21. These ratings, which are standard values for IDT commercially rated parts, are stress ratings only. Functional operation of the device at these or any other conditions above those indicated in the operational sections of the specifications is not implied. Exposure to absolute maximum rating conditions for extended periods can affect product reliability. Electrical parameters are guaranteed only over the recommended operating temperature range.

Item	Rating
Supply Voltage, VDD	7 V
All Inputs and Outputs	-0.5 V to VDD+0.5 V
Ambient Operating Temperature	0 to +70° C
Storage Temperature	-65 to +150° C
Junction Temperature	125° C
Soldering Temperature	260° C

Recommended Operation Conditions

Parameter	Min.	Typ.	Max.	Units
Ambient Operating Temperature	0		+70	°C
Power Supply Voltage (measured in respect to GND)	+3.0		+5.5	V

DC Electrical Characteristics

VDD = 5.0 V (unless noted), Temp 0 to +70° C

Parameter	Symbol	Conditions	Min.	Typ.	Max.	Units
Operating Voltage	VDD		3.0		5.5	V
Input High Voltage	V _{IH}	X1/ICLK pin only	(VDD/2)+1			V
Input Low Voltage	V _{IL}	X1/ICLK pin only			(VDD/2)-1	V
Input High Voltage	V _{IH}		2			V
Input Low Voltage	V _{IL}				0.8	V
Output High Voltage	V _{OH}	I _{OH} = -25 mA	2.4			V
Output Low Voltage	V _{OL}	I _{OL} = 25 mA			0.4	V
Output High Voltage	V _{OH}	I _{OH} = -8 mA	VDD-0.4			V
Operating Supply Current	IDD	No Load, Note 1		37		mA
Short Circuit Current	I _{OS}	Each output		±100		mA
Input Capacitance	C _{IN}			7		pF

Note 1: With processor clock at 50 MHz and ACLK at 16.93 MHz.

AC Electrical Characteristics

VDD = 5.0 V (unless noted), Temp 0 to +70° C

Parameter	Symbol	Conditions	Min.	Typ.	Max.	Units
Input Frequency				27		MHz
Output Clock Rise Time	t _{OR}	0.8 to 2.0 V			1.5	ns
Output Clock Fall Time	t _{OF}	2.0 to 0.8 V			1.5	ns
Output Clock Duty Cycle		at VDD/2	40		60	%
Frequency Error				0	1	ppm
Absolute Jitter, short term		Variation from mean		200		ps

Thermal Characteristics

Parameter	Symbol	Conditions	Min.	Typ.	Max.	Units
Thermal Resistance Junction to Ambient	θ _{JA}	Still air		120		°C/W
	θ _{JA}	1 m/s air flow		115		°C/W
	θ _{JA}	3 m/s air flow		105		°C/W
Thermal Resistance Junction to Case	θ _{JC}			58		°C/W

Package Outline and Package Dimensions (16-pin SOIC, 150 Mil. Narrow Body)

Package dimensions are kept current with JEDEC Publication No. 95

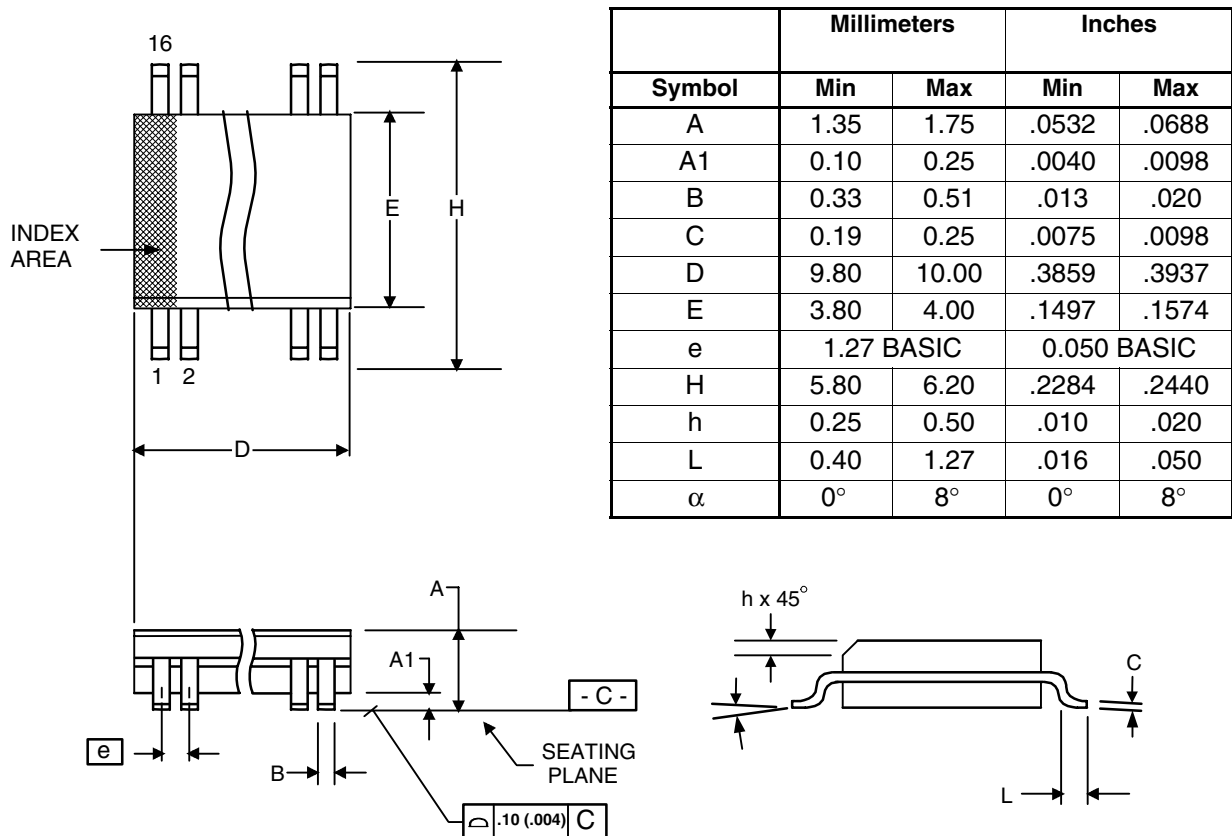

Ordering Information

Part / Order Number	Marking	Shipping Packaging	Package	Temperature
MK2745-21SLF	2745-21SLF	Tubes	16-pin SOIC	0 to 70° C
MK2745-21SLFTR	2745-21SLF	Tape and Reel	16-pin SOIC	0 to 70° C

“LF” denotes Pb (lead) free package

While the information presented herein has been checked for both accuracy and reliability, Integrated Device Technology (IDT) assumes no responsibility for either its use or for the infringement of any patents or other rights of third parties, which would result from its use. No other circuits, patents, or licenses are implied. This product is intended for use in normal commercial applications. Any other applications such as those requiring extended temperature range, high reliability, or other extraordinary environmental requirements are not recommended without additional processing by IDT. IDT reserves the right to change any circuitry or specifications without notice. IDT does not authorize or warrant any IDT product for use in life support devices or critical medical instruments.

IMPORTANT NOTICE AND DISCLAIMER

RENESAS ELECTRONICS CORPORATION AND ITS SUBSIDIARIES (“RENESAS”) PROVIDES TECHNICAL SPECIFICATIONS AND RELIABILITY DATA (INCLUDING DATASHEETS), DESIGN RESOURCES (INCLUDING REFERENCE DESIGNS), APPLICATION OR OTHER DESIGN ADVICE, WEB TOOLS, SAFETY INFORMATION, AND OTHER RESOURCES “AS IS” AND WITH ALL FAULTS, AND DISCLAIMS ALL WARRANTIES, EXPRESS OR IMPLIED, INCLUDING, WITHOUT LIMITATION, ANY IMPLIED WARRANTIES OF MERCHANTABILITY, FITNESS FOR A PARTICULAR PURPOSE, OR NON-INFRINGEMENT OF THIRD PARTY INTELLECTUAL PROPERTY RIGHTS.

These resources are intended for developers skilled in the art designing with Renesas products. You are solely responsible for (1) selecting the appropriate products for your application, (2) designing, validating, and testing your application, and (3) ensuring your application meets applicable standards, and any other safety, security, or other requirements. These resources are subject to change without notice. Renesas grants you permission to use these resources only for development of an application that uses Renesas products. Other reproduction or use of these resources is strictly prohibited. No license is granted to any other Renesas intellectual property or to any third party intellectual property. Renesas disclaims responsibility for, and you will fully indemnify Renesas and its representatives against, any claims, damages, costs, losses, or liabilities arising out of your use of these resources. Renesas' products are provided only subject to Renesas' Terms and Conditions of Sale or other applicable terms agreed to in writing. No use of any Renesas resources expands or otherwise alters any applicable warranties or warranty disclaimers for these products.

(Rev.1.0 Mar 2020)

Corporate Headquarters

TOYOSU FORESIA, 3-2-24 Toyosu,
Koto-ku, Tokyo 135-0061, Japan
www.renesas.com

Contact Information

For further information on a product, technology, the most up-to-date version of a document, or your nearest sales office, please visit:
www.renesas.com/contact/

Trademarks

Renesas and the Renesas logo are trademarks of Renesas Electronics Corporation. All trademarks and registered trademarks are the property of their respective owners.