

ISL6421

Single Output LNB Supply and Control Voltage Regulator with I²C Interface for Advanced Satellite Set-top Box Designs

FN9130
Rev 1.00
Jul 2004

The ISL6421 is a highly integrated solution for supplying power and control signals from advanced satellite set-top box (STB) modules to the low noise block (LNB). This device is comprised of a current-mode boost PWM and a low-noise linear regulator, along with the circuitry required for I²C device interfacing and for providing DiSEqC™ standard control signals to the LNB.

A regulated output voltage is available at the output terminal (VOUT) to support the operation of the antenna port in advanced satellite STB applications. The regulated output may be set to either 13V or 18V by use of the voltage select command (VSEL) through the I²C bus. Additionally, to compensate for the voltage drop in the coaxial cable, the voltage may be increased by 1V with the line length compensation (LLC) feature. An enable command sent on the I²C bus provides standby mode control for the PWM and linear combination, disabling the output to conserve power.

A current-mode boost converter provides the linear regulator with an input voltage that is set to the required output voltage, plus 1.2V (typ.) to insure minimum power dissipation. This maintains a constant voltage drop across the linear pass element, while permitting an adequate voltage range for tone injection.

The device is capable of providing 450mA (typ.).

Ordering Information

PART NUMBER	TEMP. RANGE (°C)	PACKAGE	PKG. DWG. #
ISL6421ER	-20 to 85	32 Ld 5x5 QFN	L32.5x5
ISL6421ER-T		32 Ld 5x5 QFN Tape and Reel	L32.5x5
ISL6421ERZ (See Note)	-20 to 85	32 Ld 5x5 QFN (Pb-free)	L32.5x5
ISL6421ERZ-T (See Note)		32 Ld 5x5 QFN Tape and Reel (Pb-free)	L32.5x5

NOTE: Intersil Pb-free products employ special Pb-free material sets; molding compounds/die attach materials and 100% matte tin plate termination finish, which is compatible with both SnPb and Pb-free soldering operations. Intersil Pb-free products are MSL classified at Pb-free peak reflow temperatures that meet or exceed the Pb-free requirements of IPC/JEDEC J Std-020B.

Features

- Switch-Mode Power Converter for Lowest Dissipation
 - Boost PWM with >92% Efficiency
 - Selectable 13V or 18V Outputs
 - Digital Cable Length Compensation (1V)
- External Pin to Select 13V/18V Options
- I²C Compatible Interface for Remote Device Control
 - Registered Slave Address 0001 00XX
 - Fully Functional 3.3V, 5V Operation up to 400kHz
- Built-In Tone Oscillator Factory Trimmed to 22kHz
 - Facilitates DiSEqC (EUTELSAT) Encoding
- Internal Over-Temperature Protection and Diagnostics
- Internal Overload and Overtemp Flags (Visible on I²C)
- LNB Short-Circuit Protection and Diagnostics
- QFN Package
 - Compliant to JEDEC PUB95 MO-220 QFN - Quad Flat No Leads - Product Outline
 - Near Chip-Scale Package Footprint
- Pb-free available

Applications

- LNB Power Supply and Control for Satellite Set-Top Box

References

- Tech Brief 389 (TB389) - "PCB Land Pattern Design and Surface Mount Guidelines for QFN Packages"; Available on the Intersil website, www.intersil.com

Pinout

ISL6421ER (32 LEAD 5X5 QFN)
TOP VIEW

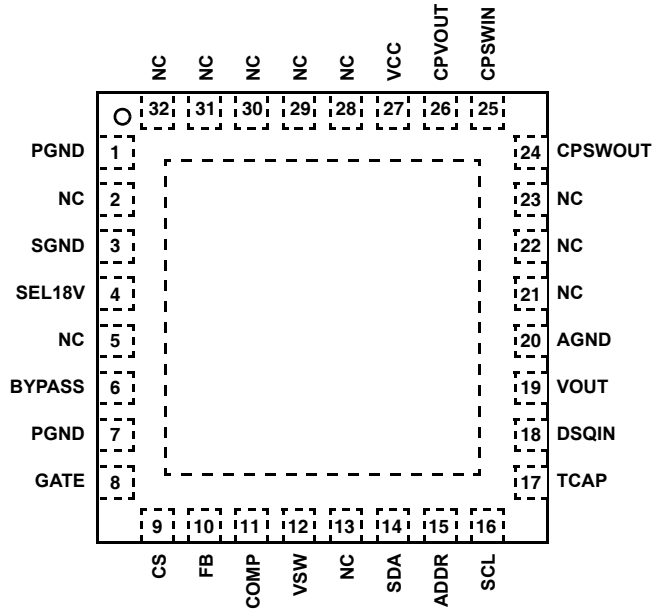

Typical Application Schematic

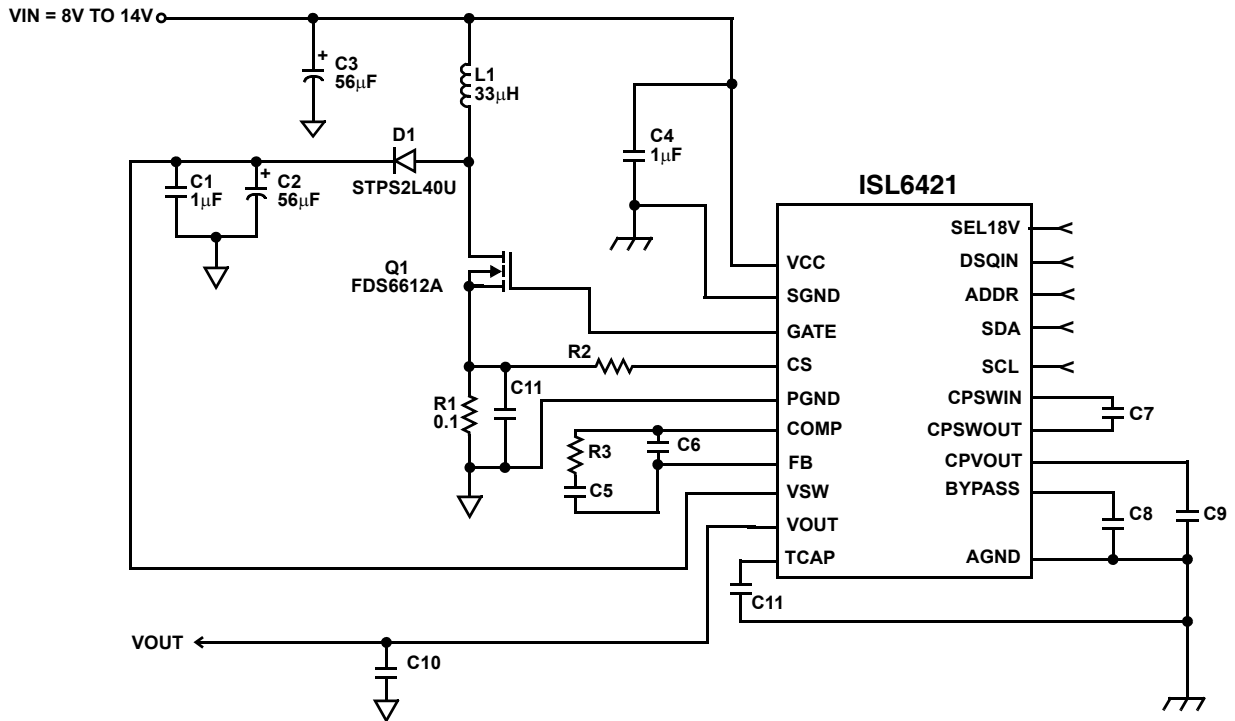

Block Diagram

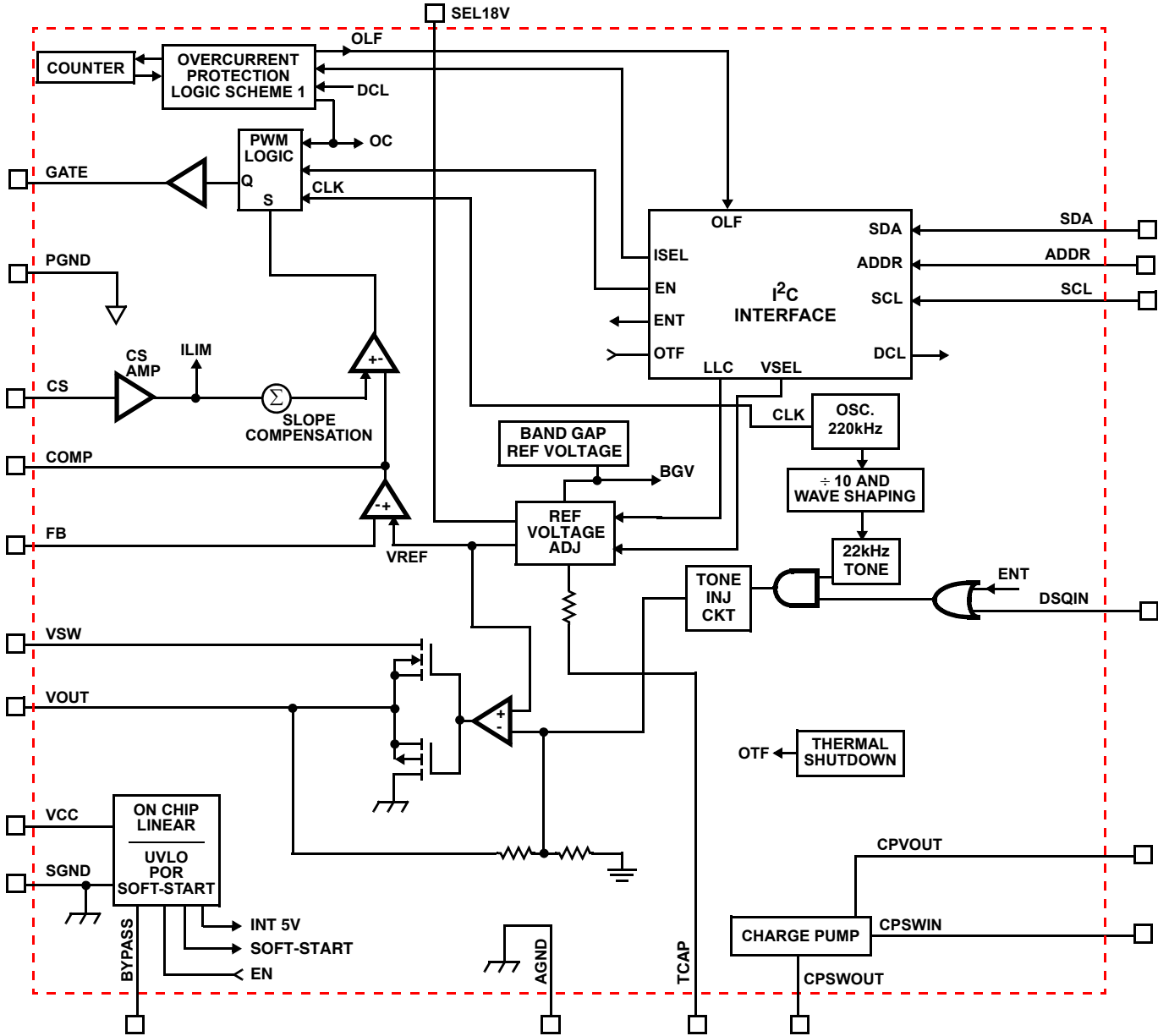

Absolute Maximum Ratings

Supply Voltage, V_{CC} 8.0V to 18.0V
 Logic Input Voltage Range (SDA, SCL, ENT) -0.5V to 7V
 Output Current Externally/Internally Limited

Thermal Information

Thermal Resistance θ_{JA} ($^{\circ}\text{C}/\text{W}$) θ_{JC} ($^{\circ}\text{C}/\text{W}$)
 QFN Package (Notes 1, 2) 32 4
 Maximum Junction Temperature 150 $^{\circ}\text{C}$
 Maximum Storage Temperature Range -40 $^{\circ}\text{C}$ to 150 $^{\circ}\text{C}$
 Maximum Lead Temperature (Soldering 10s) 300 $^{\circ}\text{C}$
 (SOIC - Lead Tips Only)
 NOTE: The device junction temperature should be kept below 150 $^{\circ}\text{C}$. Thermal shut-down circuitry turns off the device if junction temperature exceeds +150 $^{\circ}\text{C}$ typically.

CAUTION: Stresses above those listed in "Absolute Maximum Ratings" may cause permanent damage to the device. This is a stress only rating and operation of the device at these or any other conditions above those indicated in the operational sections of this specification is not implied.

NOTES:

- θ_{JA} is measured in free air with the component mounted on a high effective thermal conductivity test board with "direct attach" features. See Tech Brief TB379.
- For θ_{JC} , the "case temperature" location is the center of the exposed metal pad on the package underside. See Tech Brief TB379.

Electrical Specifications $V_{CC} = 12\text{V}$, $T_A = -20^{\circ}\text{C}$ to $+85^{\circ}\text{C}$, unless otherwise noted. Typical values are at $T_A = 25^{\circ}\text{C}$. EN = H, LLC = L, ENT = L, DCL = L, DSQIN = L, $I_{OUT} = 12\text{mA}$, unless otherwise noted. See software description section for I²C access to the system.

PARAMETER	SYMBOL	TEST CONDITIONS	MIN	TYP	MAX	UNITS
Operating Supply Voltage Range			8	12	14	V
Standby Supply Current		EN = L	-	1.5	3.0	mA
Supply Current	I_{IN}	EN = LLC = VSEL = ENT = H, No Load	-	4.0	8.0	mA
UNDER VOLTAGE LOCKOUT						
Start Threshold			7.5	-	7.95	V
Stop Threshold			7.0	-	7.55	V
Start to Stop Hysteresis			350	400	500	mV
SOFT START						
COMP Rise Time (Note 2)		(Note 4)	-	1024	-	Cycles
OUTPUT VOLTAGE						
Output Voltage (Note 3)	V_{OUT}	VSEL = L, LLC = L	12.74	13.0	13.26	V
	V_{OUT}	VSEL = L, LLC = H	13.72	14.0	14.28	V
	V_{OUT}	VSEL = H, LLC = L	17.64	18.0	18.36	V
	V_{OOU}	VSEL = H, LLC = H	18.62	19.0	19.38	V
Line Regulation	DV_{OUT}	$V_{IN} = 8\text{V to }14\text{V}; V_{OUT} = 13\text{V}$	-	4.0	40.0	mV
		$V_{IN} = 8\text{V to }14\text{V}; V_{OUT} = 18\text{V}$	-	4.0	60.0	mV
Load Regulation	DV_{OUT}	$I_O = 12\text{mA to }450\text{mA}$	-	50	80	mV
Dynamic Output Current Limiting	I_{MAX}	DCL = L	575	-	950	mA
Dynamic Overload Protection Off Time	TOFF	DCL = L, Output Shorted (Note 4)	-	900	-	ms
Dynamic Overload Protection On Time	TON		-	20	-	ms
22kHz TONE						
Tone Frequency	f_{tone}	ENT = H	20.0	22.0	24.0	kHz
Tone Amplitude	V_{tone}	ENT = H	550	680	900	mV
Tone Duty Cycle	dc_{tone}	ENT = H	40	50	60	%
Tone Rise or Fall Time	T_r, T_f	ENT = H	5	8	14	μs

Electrical Specifications $V_{CC} = 12V$, $T_A = -20^{\circ}C$ to $+85^{\circ}C$, unless otherwise noted. Typical values are at $T_A = 25^{\circ}C$. EN = H, LLC = L, ENT = L, DCL = L, DSQIN = L, $I_{OUT} = 12mA$, unless otherwise noted. See software description section for I²C access to the system. **(Continued)**

PARAMETER	SYMBOL	TEST CONDITIONS	MIN	TYP	MAX	UNITS
LINEAR REGULATOR						
Drop-out Voltage		$I_{out} = 450mA$ (Note 4)	-	1.2	-	V
DSQIN PIN						
DSQIN pin logic Low			-	-	1.5V	V
DSQIN pin Logic HIGH			3.5	-	-	V
DSQIN pin Input Current			-	1	-	μA
CURRENT SENSE						
Current Limiting Threshold (max. input)			150	200	250	mV
Input Bias Current	I_{BIAS}		-	700	-	nA
Over Current Threshold		Static current mode, DCL = H	325	400	500	mV
ERROR AMPLIFIER						
Open Loop Voltage Gain	A_{OL}	(Note 4)	70	88	-	dB
Gain Bandwidth Product	GBP	(Note 4)	10	-	-	MHz
PWM						
Maximum Duty Cycle			90	93	-	%
Minimum Pulse Width		(Note 4)	-	20	-	ns
OSCILLATOR						
Oscillator Frequency	f_o	Fixed at $(10)(f_{tone})$	200	220	240	kHz
THERMAL PROTECTION						
Thermal Shutdown						
Temperature Shutdown Threshold		(Note 4)	-	150	-	
Temperature Shutdown Hysteresis		(Note 4)	-	20	-	

NOTES:

3. Internal Digital Soft-start
4. Voltage programming signals VSEL and LLC are implemented via the I²C bus.
 $I_O = 450mA$.
5. Guaranteed by Design.

Functional Pin Description

SYMBOL	FUNCTION
SDA	Bidirectional data from/to I ² C bus.
SCL	Clock from I ² C bus.
VSW	Input of the linear post-regulator.
PGND	Dedicated ground for the output gate driver of the PWM.
CS	Current sense input; connect Rsc at this pin for desired over current value for the PWM.
SGND	Small signal ground for the IC.
AGND	Analog ground for the IC.
TCAP	Capacitor for setting rise and fall time of the output of the LNB. Use a capacitor value of 1μF or higher.
BYPASS	Bypass capacitor for internal 5V.
DSQIN	When HIGH this pin enables the internal 22kHz modulation for the LNB, Use this pin for tone enable function for the LNB.
VCC	Main power supply to the chip.
GATE	This is the device output of the PWM. This high current driver output is capable of driving the gate of a power FET. This output is actively held low when Vcc is below the UVLO threshold.
VOUT	Output voltage for the LNB.
ADDR	Address pin to select two different addresses per voltage level at this pin.
COMP	Error amp output used for compensation.
FB	Feedback pin for the PWM.
CPVOUT, CPSWIN, CPSWOUT	Charge pump connections.
SEL18V	When connected HIGH, this pin will change the output of the PWM to 18V.

Functional Description

The ISL6421 single output voltage regulator makes an ideal choice for advanced satellite set-top box and personal video recorder applications. Both supply and control voltage outputs for a low noise block (LNB) are available simultaneously in any output configuration. The device utilizes a built-in DC/DC step-converter that, from a single supply source ranging from 8V to 14V, generates the voltage that enables the linear post-regulator to work with a minimum of dissipated power. An under voltage lockout circuit disables the circuit when V_{CC} drops below a fixed threshold (7.5V typ).

DiSEqC Encoding

The internal oscillator is factory-trimmed to provide a tone of 22kHz in accordance with DiSEqC standards. No further adjustment is required. The 22kHz oscillator can be controlled either by the I²C interface (ENT bit) or by a dedicated pin (DSQIN) that allows immediate DiSEqC data encoding for the LNB. All the functions of this IC are controlled via the I²C bus by writing to the system registers (SR). The same registers can be read back, and two bits will report the diagnostic status. The internal oscillator operates the converters at ten times the tone frequency. The device offers full I²C compatible functionality, 3.3V or 5V, and up to 400kHz operation.

If the Tone Enable (ENT) bit is set LOW through I²C, then the DSQIN terminal activates the internal tone signal, modulating the dc output with a 0.3V, 22kHz, symmetrical waveform. The

presence of this signal usually gives the LNB information about the band to be received.

Burst coding of the 22kHz tone can be accomplished due to the fast response of the DSQIN input and rapid tone response. This allows implementation of the DiSEqC (EUTELSAT) protocols.

When the ENT bit is set HIGH, a continuous 22kHz tone is generated regardless of the DSQIN pin logic status. The ENT bit must be set LOW when the DSQIN pin is used for DiSEqC encoding.

Linear Regulator

The output linear regulator will sink and source current. This feature allows full modulation capability into capacitive loads as high as 0.25μF. In order to minimize the power dissipation, the output voltage of the internal step-up converter is adjusted to allow the linear regulator to work at minimum dropout.

When the device is put in the shutdown mode (EN = LOW), the PWM power block is disabled. When the regulator block is active (EN = HIGH), the output can be logic controlled to be 13V or 18V (typical) by means of the VSEL bit (Voltage Select) for remote controlling of non-DiSEqC LNBs. Additionally, it is possible to increment by 1V (typical) the selected voltage value to compensate for the excess voltage drop along the coaxial cable (LLC bit HIGH).

Output Timing

The programmed output voltage rise and fall times can be set by an external capacitor. The output rise and fall times will be approximately 3400 times the TCAP value. For the recommended range of 0.47µF to 2.2µF, the rise and fall time would be 1.6ms to 7.6ms. Using a 0.47µF capacitor insures the PWM stays below its overcurrent threshold when charging a 120µF VSW filter cap during the worst case 13V to 19V transition. A typical value of 1.0µF is recommended. This feature affects the programmed voltage rise and fall times.

Current Limiting (Only one ISEL option needed)

The current limiting block can operate either statically (simple current clamp) or dynamically. The threshold is between 575mA and 950mA. When the DCL (Dynamic Current Limiting) bit is set to LOW, the over current protection circuit works dynamically. That is, as soon as an overload is detected, the output is shutdown for a time t_{OFF}, typically 900ms. Simultaneously the overload flag (OLF) bit of the system register is set to HIGH. After this time has elapsed, the output is resumed for a time Ton = 20ms. During Ton, the device output will be current limited to between 575mA and 950mA. At the end of Ton, if the overload is still detected, the protection circuit will cycle again through Toff and Ton. At the end of a full Ton during which no overload is detected, normal operation is resumed and the OLF bit is reset to LOW. Typical Ton+Toff time is 920ms as determined by an internal timer. This dynamic operation can greatly reduce the power dissipation in a short circuit condition, still ensuring excellent power-on start-up in most conditions.

However, there could be some cases in which a highly capacitive load on the output may cause a difficult start-up, when the dynamic protection is chosen. This can be solved by initiating a power start-up in static mode (DCL = HIGH) and then switching to the dynamic mode (DCL = LOW) after a chosen amount of time. When in static mode, the OLF bit goes HIGH when the current clamp limit is reached and returns LOW when the overload condition is cleared. The OLF bit will be LOW at the end of initial power-on soft-start.

Thermal Resistance

This IC is protected against overheating. When the junction temperature exceeds 150°C (typical), the step-up converter and the linear regulator are shut off and the overtemp flag (OTF) bit of the SR is set HIGH. Normal operation is resumed and the OTF bit is reset LOW, when the junction is cooled down to 130°C (typical).

External Output Voltage Selection

The output voltage can be selected by the I²C bus. Additionally, the QFN package offers a pin (SEL18V) for independent 13V/18V output voltage selection. When using this pin, the I²C bits should be initialized to 13V status.

TABLE 1.

I ² C BITS	SEL18V	O/P VOLTAGE
13V	Low	13V

TABLE 1.

I ² C BITS	SEL18V	O/P VOLTAGE
13V	High	18V

I²C Bus Interface for ISL6421

(Refer to Philips I²C Specification, Rev. 2.1)

Data transmission from main microprocessor to the ISL6421 and vice versa takes place through the 2 wires I²C bus interfaces, consisting of the two lines SDA and SCL. Both SDA and SCL are bidirectional lines, connected to a positive supply voltage via a pull up resistor. (Pull up resistors to positive supply voltage must be externally connected). When the bus is free, both lines are HIGH. The output stage of ISL6421 will have an open drain/open collector in order to perform the wired-AND function. Data on the I²C bus can be transferred up to 100kbits/s in the standard-mode or up to 400kbits/s in the fast-mode. The level of logic “0” and logic “1” is dependent of associated value of V_{dd} as per electrical specification table. One clock pulse is generated for each data bit transferred.

Data Validity

The data on the SDA line must be stable during the HIGH period of the clock. The HIGH or LOW state of the data line can only change when the clock signal on the SCL line is LOW. Refer to Figure 1.

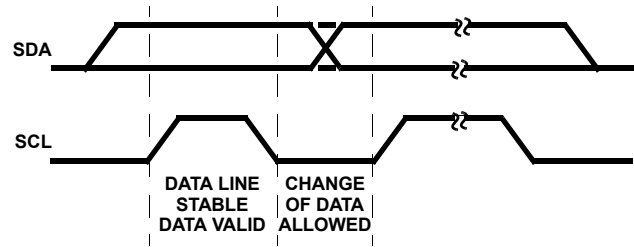

FIGURE 1. DATA VALIDITY

START and STOP Conditions

As shown in the Figure 2, START condition is a HIGH to LOW transition of the SDA line, while SCL is HIGH. The STOP condition is a LOW to HIGH transition on the SDA line, while SCL is HIGH. A STOP condition must be sent before each START condition.

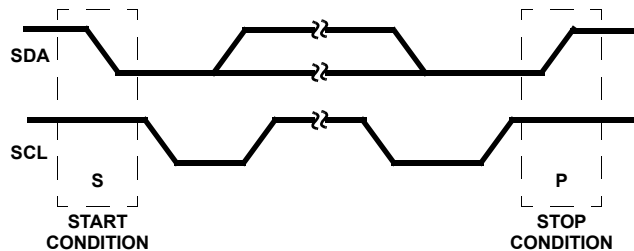

FIGURE 2. START AND STOP WAVEFORMS

Byte Format

Every byte put on the SDA line must be 8-bits long. The number of bytes that can be transmitted per transfer is unrestricted. Each byte has to be followed by an acknowledge bit. Data is transferred with the most significant bit first (MSB).

Acknowledge

The master (microprocessor) puts a resistive HIGH level on the SDA line during the acknowledge clock pulse (Figure 3). The peripheral that acknowledges has to pull down (LOW) the SDA line during the acknowledge clock pulse, so that the SDA line is stable LOW during this clock pulse. (Of course, set-up and hold times must also be taken into account.)

The peripheral which has been addressed has to generate an acknowledge after the reception of each byte, otherwise the SDA line remains at the HIGH level during the ninth clock pulse time. In this case, the master transmitter can generate the STOP information in order to abort the transfer. The ISL6421 will not generate the acknowledge if the POWER OK signal from the UVLO is LOW.

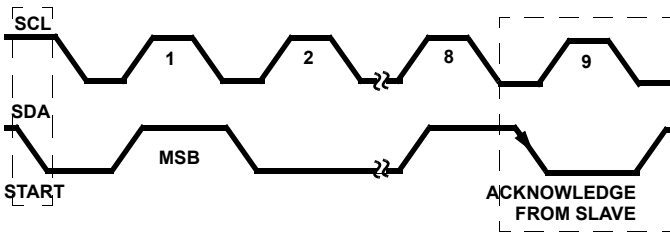

FIGURE 3. ACKNOWLEDGE ON THE I²C BUS

Avoiding detection of the acknowledgement, the microprocessor can use a simpler transmission; it waits one clock without checking the slave acknowledging, and sends the new data.

This approach, though, is less protected from error and decreases the noise immunity.

ISL6421 Software Description

Interface Protocol

The interface protocol is comprised of the following, as shown below in Table 2:

- A start condition (S)
- A chip address byte (MSB on left; the LSB bit determines read (1) or write (0) transmission) (the assigned I²C slave address for the ISL6421 is 0001 00XX)
- A sequence of data (1 byte + Acknowledge)
- A stop condition (P)

TABLE 2. INTERFACE PROTOCOL

S	0	0	0	1	0	0	0	R/W	ACK	Data (8 bits)	ACK	P
---	---	---	---	---	---	---	---	-----	-----	---------------	-----	---

Transmitted Data (I²C bus WRITE mode)

When the R/W bit in the chip is set to 0, the main microprocessor can write on the system register (SR1) of the ISL6421 via I²C bus. These will be written by the microprocessor as shown below.

Transmission Without Acknowledge

TABLE 3. SYSTEM REGISTER 1 (SR1)

R, W	R, W	R, W	R, W	R, W	R, W	R, W	R
SR1	DCL	X	ENT1	LLC1	VSEL1	EN1	OLF1

TABLE 4. SYSTEM REGISTER 2 (SR2)

R, W	R, W	R, W	R, W	R, W	R, W	R	R
SR2	X	X	X	X	EN2	OTF	X

System Register Format

- R, W = Read and Write bit
 - R = Read-only bit
- All bits reset to 0 at Power-On

TABLE 5. SYSTEM REGISTER (SR1 AND SR2) CONFIGURATION

SR	DCL	ISEL1	ENT1	LLC1	VSEL1	EN1	OLF1	FUNCTION
0		1		0	0	1		SR1 is selected
0		1		0	0	1		Vout1 = 13V, Vboost1 = 13V + Vdrop
0		1		0	1	1		Vout1 = 18V, Vboost1 = 18V + Vdrop
0		1		1	0	1		Vout1 = 14V, Vboost1 = 14V + Vdrop
0		1		1	1	1		Vout1 = 19V, Vboost1 = 19V + Vdrop
0		1	0			1		22kHz tone is controlled by the DSQIN pin
0		1	1			1		22kHz tone is ON, the DSQIN input is disabled
0	1	1				1		Dynamic current limit NOT selected
0	0	1				1		Dynamic current limit selected
0	X	1	X	X	X	0		PWM and Linear for channel 1 disabled

SR	-	-	-	-	EN2	OTF	-	FUNCTION
1	X	X	X	X	0	X	X	SR2 is selected; to read OTF flag.

Received Data (I²C Bus Read Mode)

The ISL6421 can provide to the master a copy of the System Register information via the I²C bus in read mode. The read mode is Master activated by sending the chip address with R/W bit set to 1. At the following Master generated clock bits, the ISL6421 issues a byte on the SDA data bus line (MSB transmitted first).

At the ninth clock bit the MCU master can:

- Acknowledge the reception, starting in this way the transmission of another byte from the ISL6421.
- Not acknowledge, stopping the read mode communication.

While the whole register is read back by the microprocessor, only the two read-only bits, OLF and OTF, convey diagnostic information about the ISL6421.

TABLE 6. READING SYSTEM REGISTERS

DCL	ISEL	ENT	LLC	VSEL	EN	OTF	OLF	FUNCTION
These bits are read as they were after the last write operation.						0		T _j ≤ 130°C, Normal operation
						1		T _j > 150°C, Power blocks disabled
							0	I _{out} < I _{max} , Normal operation
							1	I _{out} > I _{max} , Overload protection triggered

Power-On I²C Interface Reset

The I²C interface built into the ISL6421 is automatically reset at power-on. The I²C interface block will receive a Power OK logic signal from the UVLO circuit. This signal will go HIGH when chip power is OK. As long as this signal is LOW, the interface will not respond to any I²C commands and the system register SR is initialized to all zeros, thus keeping the power blocks disabled.

Once V_{cc} rises above the UVLO level, the POWER OK signal given to the I²C interface block will be HIGH, the I²C interface becomes operative and the SR can be configured by the main microprocessor. About 400mV of hysteresis is provided in the UVLO threshold to avoid false triggering of the Power-On reset circuit.

(I²C comes up with EN = 0, EN goes HIGH at the same time as (or later than) all other I²C data for the PWM becomes valid).

ADDRESS Pin

Connecting this pin to GND forces the chip I²C interface address to 0001000; applying a voltage >2.7V forces the address to 0001001, as shown below.

TABLE 7. ADDRESS PIN CHARACTERISTICS

VADDR	MIN	TYP	MAX
Vaddr-1 "0001000"	0V	-	2.0V
Vaddr-2 "0001001"	2.7V	-	5.0V

I²C Electrical Characteristics**TABLE 8. I²C SPECIFICATIONS**

PARAMETER	TEST CONDITION	MIN	TYP	MAX
Input Logic High, VIH	SDA, SCL		0.7 x V _{DD}	
Input Logic Low, VIL	SDA, SCL		0.3 x V _{DD}	
Input Logic Current, IIL	SDA, SCL; 0.4V < V _{in} < 4.5V			10μA
SCL Clock Frequency		0	100kHz	400kHz

© Copyright Intersil Americas LLC 2003-2004. All Rights Reserved.
All trademarks and registered trademarks are the property of their respective owners.

For additional products, see www.intersil.com/en/products.html

Intersil products are manufactured, assembled and tested utilizing ISO9001 quality systems as noted in the quality certifications found at www.intersil.com/en/support/qualandreliability.html

Intersil products are sold by description only. Intersil may modify the circuit design and/or specifications of products at any time without notice, provided that such modification does not, in Intersil's sole judgment, affect the form, fit or function of the product. Accordingly, the reader is cautioned to verify that datasheets are current before placing orders. Information furnished by Intersil is believed to be accurate and reliable. However, no responsibility is assumed by Intersil or its subsidiaries for its use; nor for any infringements of patents or other rights of third parties which may result from its use. No license is granted by implication or otherwise under any patent or patent rights of Intersil or its subsidiaries.

For information regarding Intersil Corporation and its products, see www.intersil.com

**Quad Flat No-Lead Plastic Package (QFN)
Micro Lead Frame Plastic Package (MLFP)**

L32.5x5

**32 LEAD QUAD FLAT NO-LEAD PLASTIC PACKAGE
(COMPLIANT TO JEDEC MO-220VHHD-2 ISSUE C**

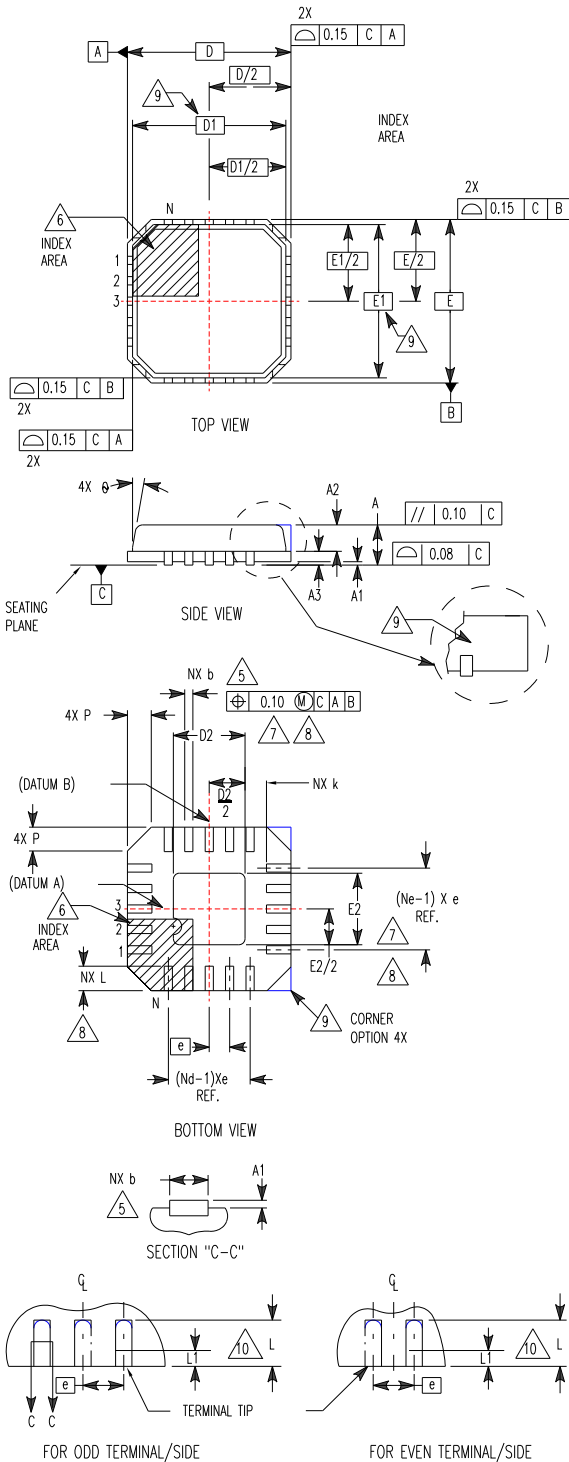

SYMBOL	MILLIMETERS			NOTES
	MIN	NOMINAL	MAX	
A	0.80	0.90	1.00	-
A1	-	-	0.05	-
A2	-	-	1.00	9
A3	0.20 REF			9
b	0.18	0.23	0.30	5,8
D	5.00 BSC			-
D1	4.75 BSC			9
D2	2.95	3.10	3.25	7,8
E	5.00 BSC			-
E1	4.75 BSC			9
E2	2.95	3.10	3.25	7,8
e	0.50 BSC			-
k	0.25	-	-	-
L	0.30	0.40	0.50	8
L1	-	-	0.15	10
N	32			2
Nd	8			3
Ne	8	8	-	3
P	-	-	0.60	9
θ	-	-	12	9

Rev. 1 10/02

NOTES:

1. Dimensioning and tolerancing conform to ASME Y14.5-1994.
2. N is the number of terminals.
3. Nd and Ne refer to the number of terminals on each D and E.
4. All dimensions are in millimeters. Angles are in degrees.
5. Dimension b applies to the metallized terminal and is measured between 0.15mm and 0.30mm from the terminal tip.
6. The configuration of the pin #1 identifier is optional, but must be located within the zone indicated. The pin #1 identifier may be either a mold or mark feature.
7. Dimensions D2 and E2 are for the exposed pads which provide improved electrical and thermal performance.
8. Nominal dimensions are provided to assist with PCB Land Pattern Design efforts, see Intersil Technical Brief TB389.
9. Features and dimensions A2, A3, D1, E1, P & θ are present when Anvil singulation method is used and not present for saw singulation.
10. Depending on the method of lead termination at the edge of the package, a maximum 0.15mm pull back (L1) maybe present. L minus L1 to be equal to or greater than 0.3mm.