

## ISL4260E

QFN Packaged, ±15kV ESD Protected, +3V to +5.5V, 150nA, 250kbps, RS-232 Transmitters/Receivers with Separate Logic Supply

The [ISL4260E](#) contains 3.0V to 5.5V powered RS-232 transmitters/receivers that meet EIA/TIA-232 and V.28/V.24 specifications, even at  $V_{CC} = 3.0V$ .

Targeted applications are PDAs, Palmtops, and cell phones where the low operational power consumption and even lower standby power consumption is critical. Efficient on-chip charge pumps coupled with a manual powerdown function reduces the standby supply current to a 150nA trickle. The 5mm x 5mm Quad Flat No-Lead (QFN) packaging and the use of small, low value capacitors ensure board space savings. Data rates greater than 250kbps are ensured at worst case load conditions.

The ISL4260E features a  $V_L$  pin that adjusts the logic pin output levels (see [Pin Descriptions](#)) and input thresholds to values compatible with the  $V_{CC}$  powering the external logic (for example, a UART).

The single pin powerdown function ( $\overline{SHDN} = 0$ ) disables all the receiver and transmitter outputs while shutting down the charge pump to minimize supply current drain.

[Table 1](#) summarizes the features of the ISL4260E. [Application Note AN9863](#) summarizes the features of each device comprising the 3V RS-232 family.

### Related Literature

For a full list of related documents, visit our website:

- [ISL4260E](#) device page

### Features

- Available in near chip scale QFN (5mmx5mm) package
- $V_L$  pin for compatibility with mixed voltage systems
- ESD protection for RS-232 I/O pins to ±15kV (IEC61000)
- Single  $\overline{SHDN}$  pin disables transmitters and receivers
- Meets EIA/TIA-232 and V.28/V.24 specifications at 3V
- On-chip charge pumps require only four external 0.1µF capacitors
- Receiver hysteresis for improved noise immunity
- Very low supply current: 300µA
- Guaranteed minimum data rate: 250kbps
- Wide power supply range: Single +3V to +5.5V
- Low supply current in powerdown state: 150nA
- Pb-free (RoHS compliant)

### Applications

- Any system requiring RS-232 communication ports
  - Battery powered, hand-held, and portable equipment
  - Laptop computers, notebooks, and Palmtops
  - Digital cameras
  - PDAs and PDA cradles
  - Cellular/mobile phones

**Table 1. Summary of Features**

Part Number	No. Of Tx.	No. Of Rx.	Data Rate (kbps)	Rx. Enable Function?	$V_L$ Logic Supply Pin?	Manual Powerdown?	Automatic Powerdown Function?
ISL4260E	3	2	250	No	Yes	Yes	No

## Contents

<b>1. Overview</b>	<b>3</b>
1.1 Typical Operating Circuit	3
1.2 Ordering Information	3
1.3 Pin Configuration	4
1.4 Pin Descriptions	4
<b>2. Specifications</b>	<b>5</b>
2.1 Absolute Maximum Ratings	5
2.2 Thermal Information	5
2.3 Recommended Operating Conditions	5
2.4 Electrical Specifications	6
<b>3. Typical Performance Curves</b>	<b>8</b>
<b>4. Application Information</b>	<b>10</b>
4.1 Charge Pump	10
4.1.1 Charge Pump Abs Max Ratings	10
4.2 Transmitters	11
4.3 Receivers	12
4.4 Low Power Operation	12
4.5 Powerdown Functionality	12
4.6 Software Controlled (Manual) Powerdown	12
4.7 VL Logic Supply Input	13
4.8 Capacitor Selection	13
4.9 Power Supply Decoupling	13
4.10 Transmitter Outputs when Exiting Powerdown	13
4.11 High Data Rates	14
4.12 Interconnection with 3V and 5V Logic	14
<b>5. ±15kV ESD Protection</b>	<b>15</b>
5.1 Human Body Model (HBM) Testing	15
5.2 IEC61000-4-2 Testing	15
5.3 Air-Gap Discharge Test Method	15
5.4 Contact Discharge Test Method	15
<b>6. Die Characteristics</b>	<b>16</b>
<b>7. Revision History</b>	<b>17</b>
<b>8. Package Outline Drawing</b>	<b>18</b>

# 1. Overview

## 1.1 Typical Operating Circuit

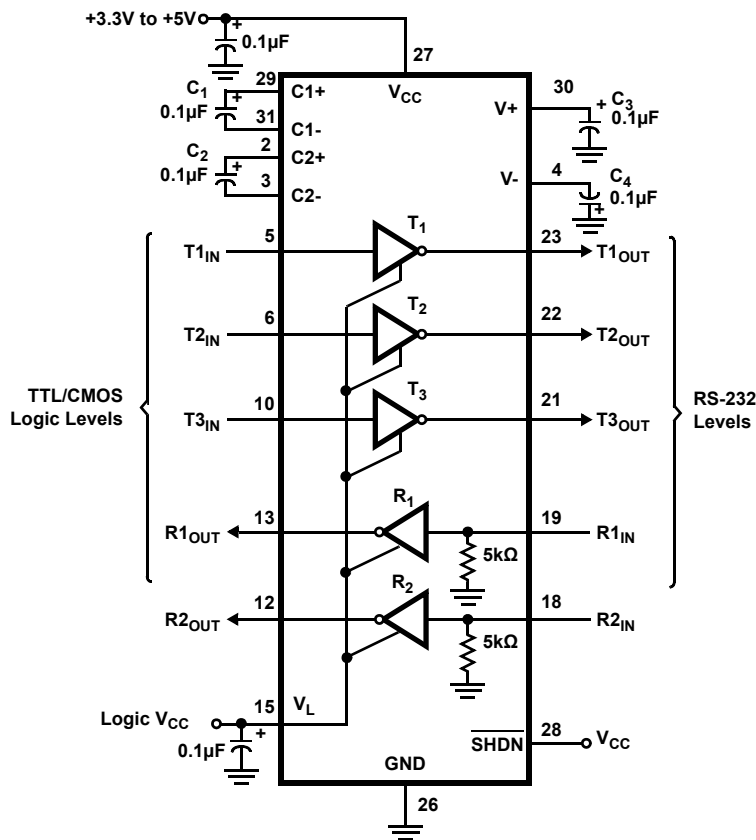

## 1.2 Ordering Information

Part Number (Notes 2, 3)	Part Marking	Temp. Range (°C)	Tape and Reel (Units) (Note 1)	Package (RoHS Compliant)	Pkg. Dwg. #.
ISL4260EIRZ	ISL4260 EIRZ	-40 to +85	-	32 Ld QFN	L32.5x5B
ISL4260EIRZ-T	ISL4260 EIRZ	-40 to +85	6k	32 Ld QFN	L32.5x5B

Notes:

1. See [TB347](#) for details about reel specifications.
2. These Pb-free plastic packaged products employ special Pb-free material sets; molding compounds/die attach materials and matte tin termination finish, which is RoHS compliant and compatible with both SnPb and Pb-free soldering operations. Pb-free products are MSL classified at Pb-free peak reflow temperatures that meet or exceed the Pb-free requirements of IPC/JEDEC J STD-020.
3. For Moisture Sensitivity Level (MSL), see the [ISL4260E](#) device page. For more information about MSL, see [TB363](#).

### 1.3 Pin Configuration

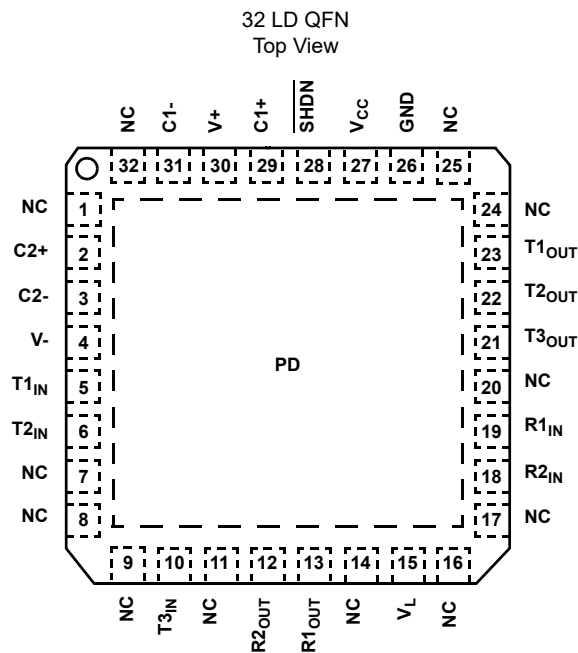

### 1.4 Pin Descriptions

Pin	Function
V <sub>CC</sub>	System power supply input (3.0V to 5.5V).
V+	Internally generated positive transmitter supply (+5.5V).
V-	Internally generated negative transmitter supply (-5.5V).
GND	Ground connection. This is also the potential of the thermal pad (PD).
C1+	External capacitor (voltage doubler) is connected to this lead.
C1-	External capacitor (voltage doubler) is connected to this lead.
C2+	External capacitor (voltage inverter) is connected to this lead.
C2-	External capacitor (voltage inverter) is connected to this lead.
T <sub>IN</sub>	TTL/CMOS compatible transmitter Inputs. The switching point is a function of the V <sub>L</sub> voltage.
T <sub>OUT</sub>	±15kV ESD protected, RS-232 level (nominally ±5.5V) transmitter outputs.
R <sub>IN</sub>	±15kV ESD protected, RS-232 compatible receiver inputs.
R <sub>OUT</sub>	TTL/CMOS level receiver outputs. Swings between GND and V <sub>L</sub> .
V <sub>L</sub>	Logic-Level Supply. All TTL/CMOS inputs and outputs are powered by this supply.
SHDN	Active low TTL/CMOS input to tri-state receiver and transmitter outputs and to shut down the onboard power supply to place the device in low power mode. The switching point is a function of the V <sub>L</sub> voltage.
NC	No connection
PD	Exposed thermal pad. Connect to GND.

## 2. Specifications

### 2.1 Absolute Maximum Ratings

Parameter	Minimum	Maximum	Unit
V <sub>CC</sub> to Ground	-0.3	6	V
V <sub>L</sub> to Ground	-0.3	7	V
V+ to Ground	-0.3	7	V
V- to Ground	+0.3	-7	V
V+ to V-		14	V
<b>Input Voltages</b>			
T <sub>IN</sub> , $\overline{\text{SHDN}}$	-0.3	6	V
R <sub>IN</sub>		±25	V
<b>Output Voltages</b>			
T <sub>OUT</sub>		±13.2	V
R <sub>OUT</sub>	-0.3	V <sub>L</sub> + 0.3	V
<b>Short-Circuit Duration</b>			
T <sub>OUT</sub>		Continuous	-
<b>ESD Rating</b>		See <a href="#">ESD Performance</a>	-

CAUTION: Do not operate at or near the maximum ratings listed for extended periods of time. Exposure to such conditions can adversely impact product reliability and result in failures not covered by warranty.

### 2.2 Thermal Information

Thermal Resistance (Typical)	$\theta_{JA}$ (°C/W)	$\theta_{JC}$ (°C/W)
32 Ld QFN Package ( <a href="#">Notes 4, 5</a> )	30	2.2

Notes:

- $\theta_{JA}$  is measured in free air with the component mounted on a high-effective thermal conductivity test board with "direct attach" features. See [TB379](#) and [TB389](#).
- For  $\theta_{JC}$ , the "case temp" location is the center of the exposed metal pad on the package underside..

Parameter	Minimum	Maximum	Unit
Maximum Junction Temperature		+150	°C
Maximum Storage Temperature Range	-65	+150	°C
Pb-Free Reflow Profile		see <a href="#">TB493</a>	

### 2.3 Recommended Operating Conditions

Parameter	Minimum	Maximum	Unit
Temperature Range	-40	+85	°C

## 2.4 Electrical Specifications

Test Conditions:  $V_{CC} = 3V$  to  $5.5V$ ,  $C_1 - C_4 = 0.1\mu F$ ,  $V_L = V_{CC}$ ; unless otherwise specified. Typical values are at  $T_A = 25^\circ C$ ,  $V_{CC} = V_L = 3.3V$

Parameter	Test Conditions	Temp (°C)	Min (Note 7)	Typ	Max (Note 7)	Unit	
<b>DC Characteristics</b>							
Supply Current, Powerdown	$\overline{SHDN} = GND$ , all inputs at $V_{CC}$ or GND	25	-	0.15	1	$\mu A$	
Supply Current	All outputs unloaded, $\overline{SHDN} = V_{CC}$ , $V_{CC} = 3.15V$	25	-	0.3	1	mA	
<b>Logic and Transmitter Inputs</b>							
Input Logic Threshold Low	$T_{IN}, \overline{SHDN}$	$V_L = 3.3V$ or $5V$	Full	-	-	0.8	V
		$V_L = 2.5V$	Full	-	-	0.6	V
Input Logic Threshold High	$T_{IN}, \overline{SHDN}$	$V_L = 5V$	Full	2.4	-	-	V
		$V_L = 3.3V$	Full	2.0	-	-	V
		$V_L = 2.5V$	Full	1.4	-	-	V
		$V_L = 1.8V$	25	-	0.9	-	V
Transmitter Input Hysteresis		25	-	0.5	-	V	
Input Leakage Current	$T_{IN}, \overline{SHDN}$	Full	-	$\pm 0.01$	$\pm 1$	$\mu A$	
<b>Receiver Outputs</b>							
Output Leakage Current	$V_{CC} = 0V$ or $3V$ to $5.5V$ , $\overline{SHDN} = GND$	Full	-	$\pm 0.05$	$\pm 10$	$\mu A$	
Output Voltage Low	$I_{OUT} = 1.6mA$	Full	-	-	0.4	V	
Output Voltage High	$I_{OUT} = -1.0mA$	Full	$V_L - 0.6$	$V_L - 0.1$	-	V	
<b>Receiver Inputs</b>							
Input Voltage Range		Full	-25	-	25	V	
Input Threshold Low	$V_L = 5.0V$	25	0.8	1.5	-	V	
	$V_L = 3.3V$	25	0.6	1.2	-	V	
Input Threshold High	$V_L = 5.0V$	25	-	1.8	2.4	V	
	$V_L = 3.3V$	25	-	1.5	2.4	V	
Input Hysteresis		25	-	0.5	-	V	
Input Resistance		25	3	5	7	k $\Omega$	
<b>Transmitter Outputs</b>							
Output Voltage Swing	All transmitter outputs loaded with $3k\Omega$ to ground	Full	$\pm 5.0$	$\pm 5.4$	-	V	
Output Resistance	$V_{CC} = V_+ = V_- = 0V$ , transmitter output = $\pm 2V$	Full	300	10M	-	W	
Output Short-Circuit Current	Shorted to GND	Full	-	-	$\pm 60$	mA	
Output Leakage Current	$V_{OUT} = \pm 12V$ , $V_{CC} = 0V$ or $3V$ to $5.5V$ , $\overline{SHDN} = GND$	Full	-	-	$\pm 25$	$\mu A$	
<b>Timing Characteristics</b>							
Maximum Data Rate	$R_L = 3k\Omega$ , $C_L = 1000pF$ , one transmitter switching	Full	250	500	-	kbps	
Receiver Propagation Delay	Receiver input to receiver output, $C_L = 150pF$	$t_{PHL}$	25	-	0.15	-	$\mu s$
		$t_{PLH}$	25	-	0.15	-	$\mu s$
Receiver Output Enable Time		25	-	200	-	ns	
Receiver Output Disable Time		25	-	200	-	ns	
Transmitter Output Enable Time	From $\overline{SHDN}$ rising edge to $T_{OUT} = \pm 3.7V$	25	-	100	-	$\mu s$	
Transmitter Skew	$t_{PHL} - t_{PLH}$ (Note 6)	25	-	100	-	ns	
Receiver Skew	$t_{PHL} - t_{PLH}$	25	-	50	-	ns	

Test Conditions:  $V_{CC} = 3V$  to  $5.5V$ ,  $C_1 - C_4 = 0.1\mu F$ ,  $V_L = V_{CC}$ ; unless otherwise specified. Typical values are at  $T_A = 25^\circ C$ ,  $V_{CC} = V_L = 3.3V$

Parameter	Test Conditions	Temp (°C)	Min (Note 7)	Typ	Max (Note 7)	Unit	
Transition Region Slew Rate	$R_L = 3k\Omega$ to $7k\Omega$ , measured from $3V$ to $-3V$ or $-3V$ to $3V$ , $V_{CC} = 3.3V$	$C_L = 150pF$ to $1000pF$	25	6	18	30	V/ $\mu s$
		$C_L = 150pF$ to $2500pF$	25	4	13	30	V/ $\mu s$
<b>ESD Performance</b>							
RS-232 Pins ( $T_{OUT}$ , $R_{IN}$ )	Human Body Model	25	-	$\pm 15$	-	kV	
	IEC61000-4-2 Air Gap Discharge	25	-	$\pm 15$	-	kV	
	IEC61000-4-2 Contact Discharge	25	-	$\pm 8$	-	kV	

Note:

6. Transmitter skew is measured at the transmitter zero crossing points.
7. Parameters with MIN and/or MAX limits are 100% tested at  $+25^\circ C$ , unless otherwise specified. Temperature limits established by characterization and are not production tested.

### 3. Typical Performance Curves

$V_{CC} = 3.3V, T_A = 25^\circ C$

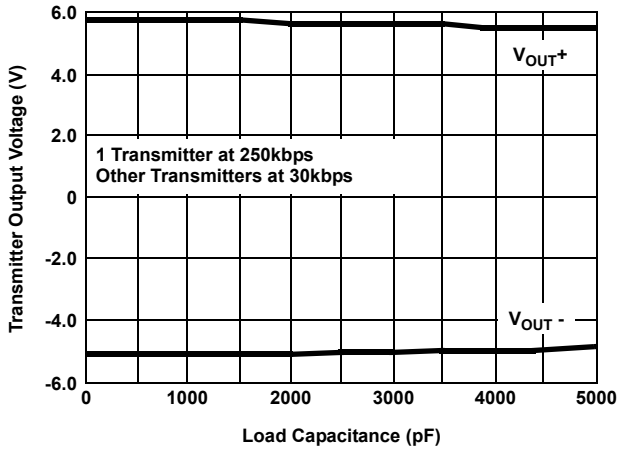

Figure 1. Transmitter Output Voltage vs Load Capacitance

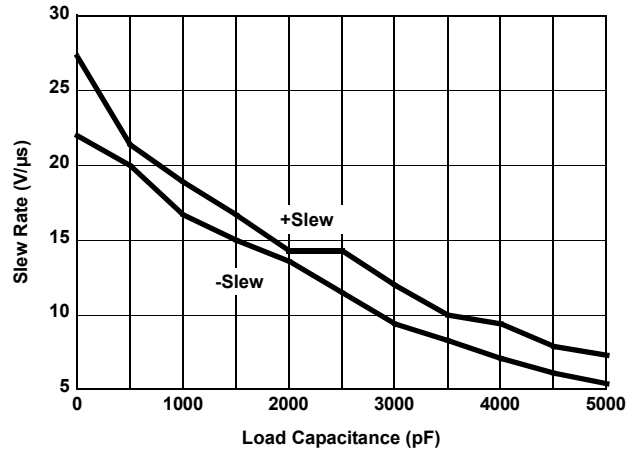

Figure 2. Slew Rate vs Load Capacitance

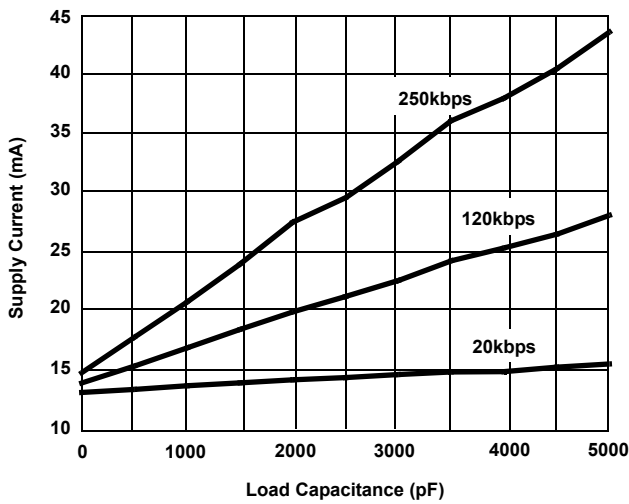

Figure 3. Supply Current vs Load Capacitance When Transmitting Data

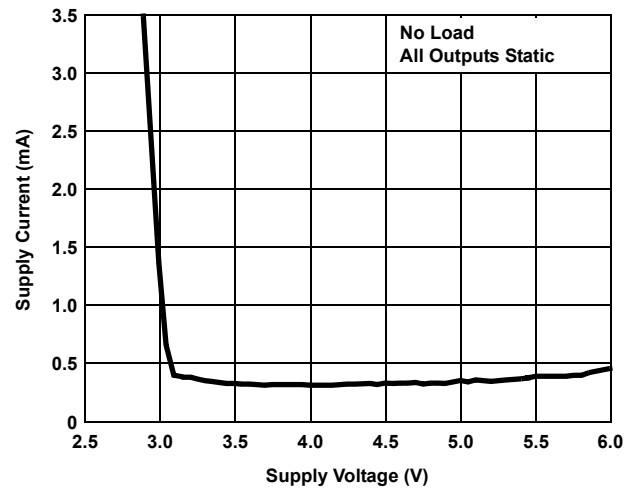

Figure 4. Supply Current vs Supply Voltage



$V_{CC} = 3.3V$ ,  $T_A = 25^\circ C$  (Continued)

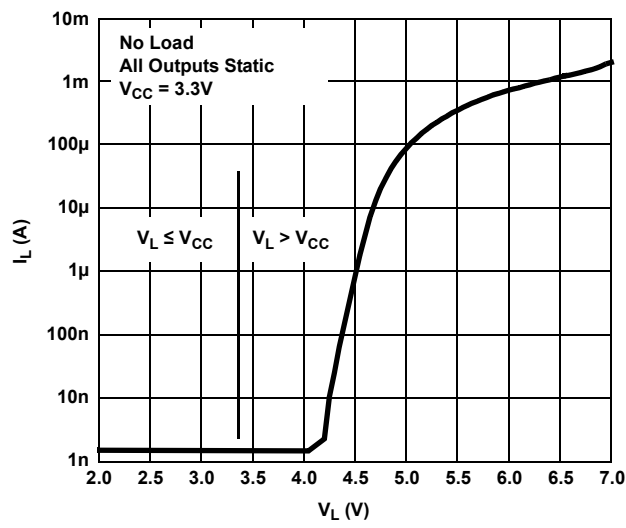

Figure 5.  $V_L$  Supply Current vs  $V_L$  Voltage

## 4. Application Information

The ISL4260E operates from a single +3V to +5.5V supply, ensures a 250kbps minimum data rate, requires only four small external 0.1 $\mu$ F capacitors, features low power consumption, and meets all EIA RS-232C and V.28 specifications.

### 4.1 Charge Pump

The ISL4260E uses regulated on-chip dual charge pumps as voltage doublers, and voltage inverters to generate  $\pm 5.5$ V transmitter supplies from a  $V_{CC}$  supply as low as 3.0V. These voltages allow the ISL4260E to maintain RS-232 compliant output levels over the  $\pm 10\%$  tolerance range of 3.3V powered systems. The efficient on-chip power supplies require only four small, external 0.1 $\mu$ F capacitors for the voltage doubler and inverter functions over the full  $V_{CC}$  range; other capacitor combinations can be used as shown in [Table 6 on page 13](#). The charge pumps operate discontinuously (turning off as soon as the V+ and V- supplies are pumped up to the nominal values) and provide significant power savings.

#### 4.1.1 Charge Pump Abs Max Ratings

The ISL4270E is fully characterized for 3.0V to 3.6V operation and at critical points for 4.5V to 5.5V operation. Furthermore, load conditions were favorable using static logic states only.

The specified maximum values for V+ and V- are +7V and -7V, respectively. These limits apply for  $V_{CC}$  values set to 3.0V and 3.6V (see [Table 2](#)). For  $V_{CC}$  values set to 4.5V and 5.5V, the maximum values for V+ and V- can approach +9V and -7V, respectively ([Table 3 on page 11](#)). The breakdown characteristics for V+ and V- were measured with  $\pm 13$ V.

**Table 2. V+ and V- Values for  $V_{CC} = 3.0$ V to 3.6V**

C <sub>1</sub> ( $\mu$ F)	C <sub>2</sub> , C <sub>3</sub> , C <sub>4</sub> ( $\mu$ F)	Load	T1IN (Logic State)	V+ (V)		V- (V)	
				V <sub>CC</sub> = 3.0V	V <sub>CC</sub> = 3.6V	V <sub>CC</sub> = 3.0V	V <sub>CC</sub> = 3.6V
0.1	0.1	Open	H	5.80	6.56	-5.60	-5.88
			L	5.80	6.56	-5.60	-5.88
			2.4kbps	5.80	6.56	-5.60	-5.88
		3k $\Omega$ // 1000pF	H	5.88	6.60	-5.56	-5.92
			L	5.76	6.36	-5.56	-5.76
			2.4kbps	6.00	6.64	-5.64	-5.96
0.047	0.33	Open	H	5.68	6.00	-5.60	-5.60
			L	5.68	6.00	-5.60	-5.60
			2.4kbps	5.68	6.00	-5.60	-5.60
		3k $\Omega$ // 1000pF	H	5.76	6.08	-5.64	-5.64
			L	5.68	6.04	-5.60	-5.60
			2.4kbps	5.84	6.16	-5.64	-5.72
1	1	Open	H	5.88	6.24	-5.60	-5.60
			L	5.88	6.28	-5.60	-5.64
			2.4kbps	5.80	6.20	-5.60	-5.60
		3k $\Omega$ // 1000pF	H	5.88	6.44	-5.64	-5.72
			L	5.88	6.04	-5.64	-5.64
			2.4kbps	5.92	6.40	-5.64	-5.64

**Table 3. V+ and V- Values for  $V_{CC} = 4.5V$  to  $5.5V$** 

$C_1$ ( $\mu F$ )	$C_2, C_3, C_4$ ( $\mu F$ )	Load	T1IN (Logic State)	V+ (V)		V- (V)	
				$V_{CC} = 4.5V$	$V_{CC} = 5.5V$	$V_{CC} = 4.5V$	$V_{CC} = 5.5V$
0.1	0.1	Open	H	7.44	8.48	-6.16	-6.40
			L	7.44	8.48	-6.16	-6.44
			2.4kbps	7.44	8.48	-6.17	-6.44
		3k $\Omega$ // 1000pF	H	7.76	8.88	-6.36	-6.72
			L	7.08	8.00	-5.76	-5.76
			2.4kbps	7.76	8.84	-6.40	-6.64
0.047	0.33	Open	H	6.44	6.88	-5.80	-5.88
			L	6.48	6.88	-5.84	-5.88
			2.4kbps	6.44	6.88	-5.80	-5.88
		3k $\Omega$ // 1000pF	H	6.64	7.28	-5.92	-6.04
			L	6.24	6.60	-5.52	-5.52
			2.4kbps	6.72	7.16	-5.92	-5.96
1	1	Open	H	6.84	7.60	-5.76	-5.76
			L	6.88	7.60	-5.76	-5.76
			2.4kbps	6.92	7.56	-5.72	-5.76
		3k $\Omega$ // 1000pF	H	7.28	8.16	-5.80	-5.92
			L	6.44	6.84	-5.64	-6.84
			2.4kbps	7.08	7.76	-5.80	-5.80

The resulting new maximum voltages at V+ and V- are listed in [Table 4](#).

**Table 4. New Measured Withstanding Voltages**

V+, V- to Ground	$\pm 13V$
V+ to V-	20V

## 4.2 Transmitters

The transmitters are proprietary, low dropout, inverting drivers that translate TTL/CMOS inputs to EIA/TIA-232 output levels. These transmitters are coupled with the on-chip  $\pm 5.5V$  supplies to deliver true RS-232 levels across a wide range of single supply system voltages.

All transmitter outputs disable and assume a high impedance state when the device enters the powerdown mode (see [Table 5](#)). The outputs can be driven to  $\pm 12V$  when disabled.

All devices guarantee a 250kbps data rate for full load conditions (3k $\Omega$  and 1000pF),  $V_{CC} \geq 3.0V$ , with one transmitter operating at full speed. Under more typical conditions of  $V_{CC} \geq 3.3V$ ,  $R_L = 3k\Omega$ , and  $C_L = 250pF$ , one transmitter easily operates at 1.25Mbps.

The transmitter input threshold is set by the voltage applied to the  $V_L$  pin. Transmitter inputs float if they are unconnected (there are no pull-up resistors), and may cause  $I_{CC}$  increases. Connect unused inputs to GND for the best performance.

**Table 5. Powerdown Truth Table**

SHDN Input	Transmitter Outputs	Receiver Outputs	Mode Of Operation
L	High-Z	High-Z	Manual Powerdown
H	Active	Active	Normal Operation

### 4.3 Receivers

The ISL4260E contains standard inverting receivers that convert RS-232 signals to CMOS output levels and accept inputs up to  $\pm 25\text{V}$  while presenting the required  $3\text{k}\Omega$  to  $7\text{k}\Omega$  input impedance (see [Figure 6 on page 12](#)) even if the power is off ( $V_{CC} = 0\text{V}$ ). The receivers' Schmitt trigger input stage uses hysteresis to increase noise immunity and decrease errors due to slow input signal transitions. Receiver outputs swing from GND to  $V_L$ , and tristate in powerdown.

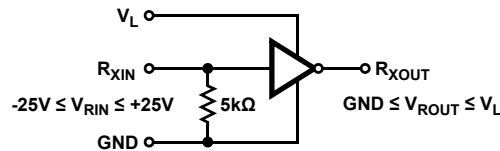

Figure 6. Receiver Connections

### 4.4 Low Power Operation

The ISL4260E requires a nominal supply current of  $0.3\text{mA}$ , even at  $V_{CC} = 5.5\text{V}$  during normal operation (not in powerdown mode). This supply current is considerably less than the  $11\text{mA}$  current required by comparable  $5\text{V}$  RS-232 devices, which allows you to reduce system power by replacing the old style device with the ISL4260E in new designs.

### 4.5 Powerdown Functionality

The already low current requirement drops significantly when the device enters powerdown mode. In powerdown, supply current drops to  $150\text{nA}$  because the on-chip charge pump turns off ( $V_+$  collapses to  $V_{CC}$ ,  $V_-$  collapses to GND), and the transmitter and receiver outputs tri-state. This micro-power mode makes the ISL4260E ideal for battery powered and portable applications.

### 4.6 Software Controlled (Manual) Powerdown

The ISL4260E can be forced into its low power, standby state with a simple shutdown ( $\overline{\text{SHDN}}$ ) pin (see [Figure 7](#)). Driving  $\overline{\text{SHDN}}$  high enables normal operation. Driving  $\overline{\text{SHDN}}$  low forces the IC into its powerdown state. The time required to exit powerdown and resume transmission is less than  $100\mu\text{s}$ . Connect  $\overline{\text{SHDN}}$  to  $V_{CC}$  if the powerdown function is not needed.

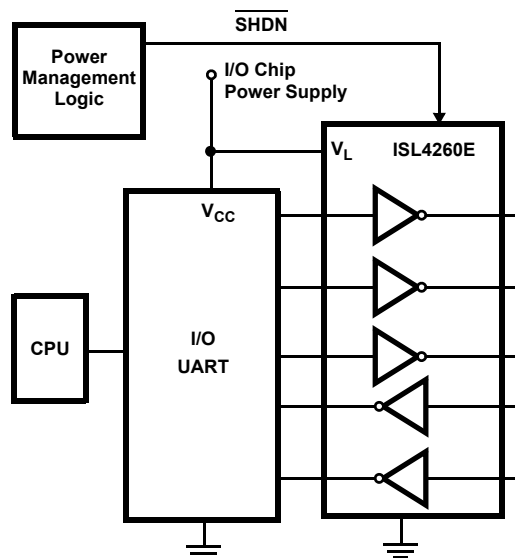

Figure 7. Connections for Manual Powerdown

## 4.7 $V_L$ Logic Supply Input

Unlike other RS-232 interface devices where the CMOS outputs swing between 0 and  $V_{CC}$ , the ISL4260E features a separate logic supply input ( $V_L$ ; 1.8V to 5V, regardless of  $V_{CC}$ ) that sets  $V_{OH}$  for the receiver outputs. Connecting  $V_L$  to a host logic supply lower than  $V_{CC}$  prevents the ISL4260E outputs from forward biasing the input diodes of a logic device powered by that lower supply. Connecting  $V_L$  to a logic supply greater than  $V_{CC}$  ensures that the receiver output levels are compatible even with the CMOS input  $V_{IH}$  of AC, HC, and CD4000 devices. **Note:** The  $V_L$  supply current increases to 100 $\mu$ A with  $V_L = 5V$  and  $V_{CC} = 3.3V$  (see [Figure 5](#)).  $V_L$  also powers the transmitter and logic inputs and sets their switching thresholds to levels compatible with the logic supply. The  $V_L$  separate logic supply pin allows a great deal of flexibility in interfacing to systems with different logic supplies. If logic translation is not required, connect  $V_L$  to the ISL4260E  $V_{CC}$ .

## 4.8 Capacitor Selection

The ISL4260E charge pumps require only 0.1 $\mu$ F capacitors for the full operational voltage range. [Table 6](#) lists other acceptable capacitor values for various supply voltage ranges. Do not use values smaller than those listed in [Table 6](#). Increasing the capacitor values (by a factor of 2) reduces ripple on the transmitter outputs and slightly reduces power consumption.

**Table 6. Required Capacitor Values**

$V_{CC}$ (V)	$C_1$ ( $\mu$ F)	$C_2, C_3, C_4$ ( $\mu$ F)
3.0 to 3.6	0.1	0.1
4.5 to 5.5	0.047	0.33
3.0 to 5.5	0.22	1

When using minimum required capacitor values, make sure that capacitor values do not degrade excessively with temperature. If in doubt, use capacitors with a larger nominal value. The capacitor's equivalent series resistance (ESR) usually rises at low temperatures and it influences the amount of ripple on  $V+$  and  $V-$ .

## 4.9 Power Supply Decoupling

In most circumstances a 0.1 $\mu$ F bypass capacitor is adequate. In applications that are particularly sensitive to power supply noise, decouple  $V_{CC}$  to ground with a capacitor of the same value as the charge-pump capacitor  $C_1$ . Connect the bypass capacitor as close as possible to the IC.

## 4.10 Transmitter Outputs when Exiting Powerdown

[Figure 8](#) shows the response of two transmitter outputs when exiting powerdown mode. As the two transmitter outputs activate, they properly go to opposite RS-232 levels with no glitching, ringing, or undesirable transients. Each transmitter is loaded with 3k $\Omega$  in parallel with 2500pF. **Note:** The transmitters enable only when the magnitude of the supplies exceeds approximately 3V.

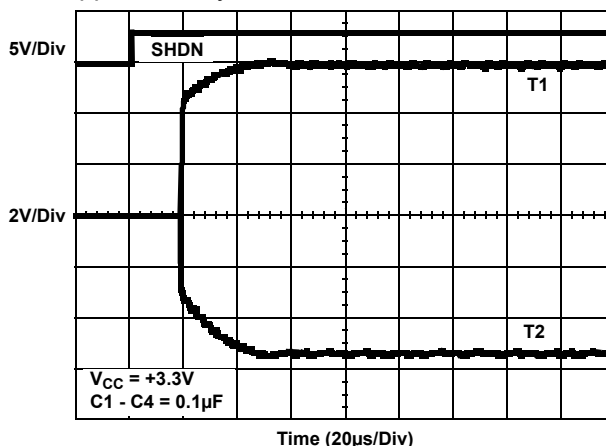

**Figure 8. Transmitter Outputs When Exiting Powerdown**

### 4.11 High Data Rates

The ISL4260E maintains the RS-232  $\pm 5V$  minimum transmitter output voltages even at high data rates. [Figure 9](#) shows a transmitter loopback test circuit, and [Figure 10](#) shows the loopback test result at 120kbps. For this test, all transmitters were simultaneously driving RS-232 loads in parallel with 1000pF at 120kbps. [Figure 11](#) shows the loopback results for a single transmitter driving 1000pF and an RS-232 load at 250kbps. The static transmitters were also loaded with an RS-232 receiver.

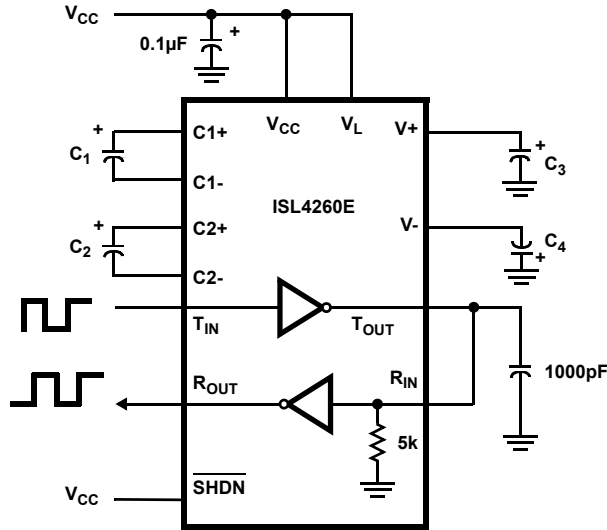

Figure 9. Transmitter Loopback Test Circuit

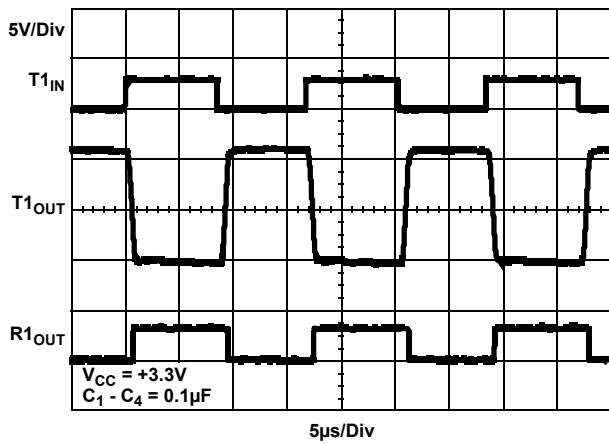

Figure 10. Loopback Test at 120kbps

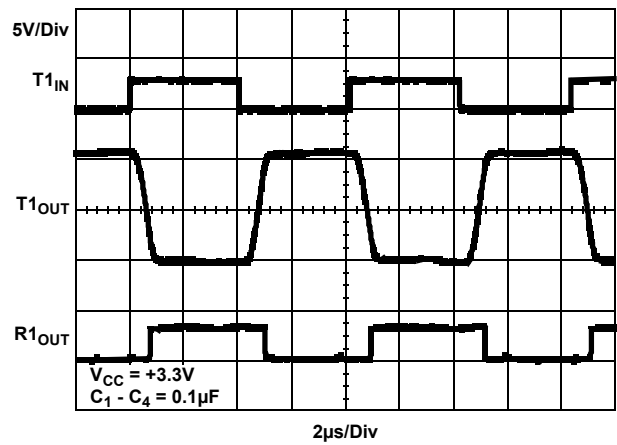

Figure 11. Loopback Test at 250kbps

### 4.12 Interconnection with 3V and 5V Logic

Standard 3.3V powered RS-232 devices interface well with 3V and 5V powered TTL compatible logic families (such as ACT and HCT), but the logic outputs (for example,  $R_{OUTS}$ ) fail to reach the  $V_{IH}$  level of 5V powered CMOS families like HC, AC, and CD4000. The ISL4260E  $V_L$  supply pin solves this problem. By connecting  $V_L$  to the same supply (1.8V to 5V) powering the logic device, the ISL4260E logic outputs swing from GND to the logic  $V_{CC}$ .

## 5. ±15kV ESD Protection

All pins on the 3V interface devices include ESD protection structures, but the ISL4260E incorporates advanced structures that allow the RS-232 pins (transmitter outputs and receiver inputs) to survive ESD events up to ±15kV. The RS-232 pins are particularly vulnerable to ESD damage because they typically connect to an exposed port on the exterior of the finished product. Touching the port pins or connecting a cable can cause an ESD event that might destroy unprotected ICs. The ESD structures protect the device whether or not it is powered up, protect without allowing any latchup mechanism to activate, and do not interfere with RS-232 signals as large as ±25V.

### 5.1 Human Body Model (HBM) Testing

The Human Body Model (HBM) test method emulates the ESD event delivered to an IC during human handling. The tester delivers the charge through a 1.5kΩ current limiting resistor, so the test is less severe than the IEC61000 test, which uses a 330Ω limiting resistor. The HBM method determines an IC's ability to withstand the ESD transients typically present during handling and manufacturing. Due to the random nature of these events, each pin is tested with respect to all other pins. The RS-232 pins on "E" family devices can withstand HBM ESD events to ±15kV.

### 5.2 IEC61000-4-2 Testing

The IEC61000 test method applies to finished equipment, rather than to an individual IC. Therefore, the pins most likely to suffer an ESD event are those that are exposed to the outside world (the RS-232 pins in this case), and the IC is tested in its typical application configuration (power applied) rather than testing each pin-to-pin combination. The lower current limiting resistor coupled with the larger charge storage capacitor yields a test that is much more severe than the HBM test. The extra ESD protection built into this device's RS-232 pins allows the design of equipment meeting level 4 criteria without the need for additional board level protection on the RS-232 port.

### 5.3 Air-Gap Discharge Test Method

For this test method, a charged probe tip moves toward the IC pin until the voltage arcs to it. The current waveform delivered to the IC pin depends on factors such as approach speed, humidity, and temperature, so it is difficult to obtain repeatable results. The "E" device RS-232 pins withstand ±15kV air-gap discharges.

### 5.4 Contact Discharge Test Method

During the contact discharge test, the probe contacts the tested pin before the probe tip is energized and eliminates the variables associated with the air-gap discharge. The result is a more repeatable and predictable test, but equipment limits prevent testing devices at voltages higher than ±8kV. All "E" family devices survive ±8kV contact discharges on the RS-232 pins.

---

## 6. Die Characteristics

Substrate and QFN Thermal Pad Potential (Powered Up)	GND
Transistor Count	422
Process	Si Gate CMOS



## 7. Revision History

Rev.	Date	Description
3.00	May.20.19	Added related literature section on page 1. Updated ordering information table on page 2. Changed Note 1 and added Note 3. Added ISL4260EIRZ-T. Added tape and reel information and notes 1, 2, and 3. Added Charge Pump Abs Max Ratings section starting on page 10. Applied new template. Added revision history. Updated disclaimer.

# 8. Package Outline Drawing

## L32.5x5B

32 LEAD QUAD FLAT NO-LEAD PLASTIC PACKAGE

Rev 3, 5/10

For the most recent package outline drawing, see [L32.5x5B](#).

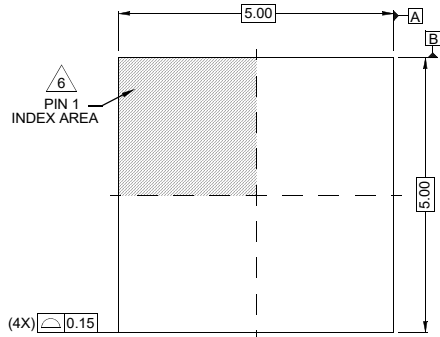

TOP VIEW

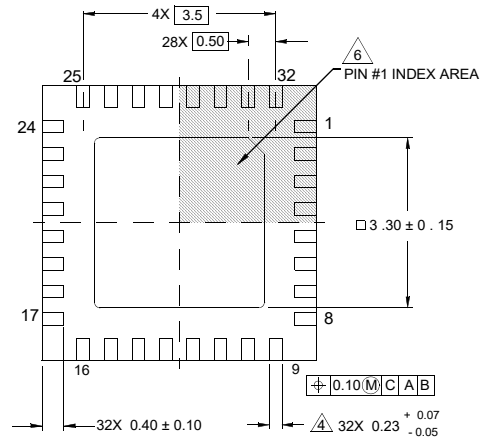

BOTTOM VIEW

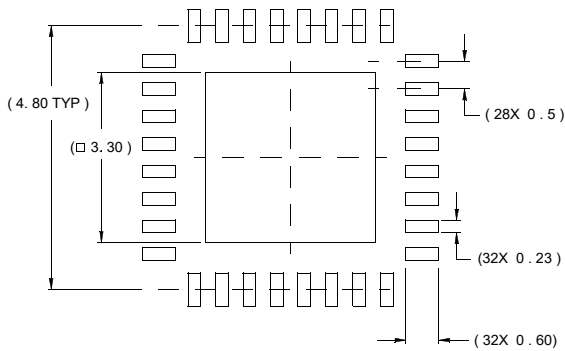

TYPICAL RECOMMENDED LAND PATTERN

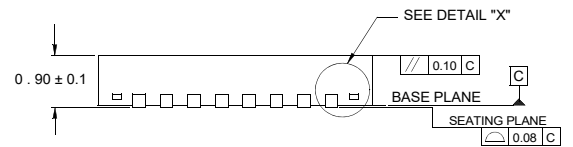

SIDE VIEW

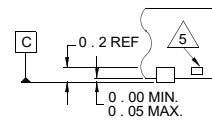

DETAIL "X"

NOTES:

1. Dimensions are in millimeters.  
Dimensions in ( ) for Reference Only.
2. Dimensioning and tolerancing conform to AMSE Y14.5m-1994.
3. Unless otherwise specified, tolerance : Decimal ± 0.05
4. Dimension applies to the metallized terminal and is measured between 0.15mm and 0.30mm from the terminal tip.
5. Tiebar shown (if present) is a non-functional feature.
6. The configuration of the pin #1 identifier is optional, but must be located within the zone indicated. The pin #1 identifier may be either a mold or mark feature.

## Notice

1. Descriptions of circuits, software and other related information in this document are provided only to illustrate the operation of semiconductor products and application examples. You are fully responsible for the incorporation or any other use of the circuits, software, and information in the design of your product or system. Renesas Electronics disclaims any and all liability for any losses and damages incurred by you or third parties arising from the use of these circuits, software, or information.
2. Renesas Electronics hereby expressly disclaims any warranties against and liability for infringement or any other claims involving patents, copyrights, or other intellectual property rights of third parties, by or arising from the use of Renesas Electronics products or technical information described in this document, including but not limited to, the product data, drawings, charts, programs, algorithms, and application examples.
3. No license, express, implied or otherwise, is granted hereby under any patents, copyrights or other intellectual property rights of Renesas Electronics or others.
4. You shall not alter, modify, copy, or reverse engineer any Renesas Electronics product, whether in whole or in part. Renesas Electronics disclaims any and all liability for any losses or damages incurred by you or third parties arising from such alteration, modification, copying or reverse engineering.
5. Renesas Electronics products are classified according to the following two quality grades: "Standard" and "High Quality". The intended applications for each Renesas Electronics product depends on the product's quality grade, as indicated below.
  - "Standard": Computers; office equipment; communications equipment; test and measurement equipment; audio and visual equipment; home electronic appliances; machine tools; personal electronic equipment; industrial robots; etc.
  - "High Quality": Transportation equipment (automobiles, trains, ships, etc.); traffic control (traffic lights); large-scale communication equipment; key financial terminal systems; safety control equipment; etc.Unless expressly designated as a high reliability product or a product for harsh environments in a Renesas Electronics data sheet or other Renesas Electronics document, Renesas Electronics products are not intended or authorized for use in products or systems that may pose a direct threat to human life or bodily injury (artificial life support devices or systems; surgical implantations; etc.), or may cause serious property damage (space system; undersea repeaters; nuclear power control systems; aircraft control systems; key plant systems; military equipment; etc.). Renesas Electronics disclaims any and all liability for any damages or losses incurred by you or any third parties arising from the use of any Renesas Electronics product that is inconsistent with any Renesas Electronics data sheet, user's manual or other Renesas Electronics document.
6. When using Renesas Electronics products, refer to the latest product information (data sheets, user's manuals, application notes, "General Notes for Handling and Using Semiconductor Devices" in the reliability handbook, etc.), and ensure that usage conditions are within the ranges specified by Renesas Electronics with respect to maximum ratings, operating power supply voltage range, heat dissipation characteristics, installation, etc. Renesas Electronics disclaims any and all liability for any malfunctions, failure or accident arising out of the use of Renesas Electronics products outside of such specified ranges.
7. Although Renesas Electronics endeavors to improve the quality and reliability of Renesas Electronics products, semiconductor products have specific characteristics, such as the occurrence of failure at a certain rate and malfunctions under certain use conditions. Unless designated as a high reliability product or a product for harsh environments in a Renesas Electronics data sheet or other Renesas Electronics document, Renesas Electronics products are not subject to radiation resistance design. You are responsible for implementing safety measures to guard against the possibility of bodily injury, injury or damage caused by fire, and/or danger to the public in the event of a failure or malfunction of Renesas Electronics products, such as safety design for hardware and software, including but not limited to redundancy, fire control and malfunction prevention, appropriate treatment for aging degradation or any other appropriate measures. Because the evaluation of microcomputer software alone is very difficult and impractical, you are responsible for evaluating the safety of the final products or systems manufactured by you.
8. Please contact a Renesas Electronics sales office for details as to environmental matters such as the environmental compatibility of each Renesas Electronics product. You are responsible for carefully and sufficiently investigating applicable laws and regulations that regulate the inclusion or use of controlled substances, including without limitation, the EU RoHS Directive, and using Renesas Electronics products in compliance with all these applicable laws and regulations. Renesas Electronics disclaims any and all liability for damages or losses occurring as a result of your noncompliance with applicable laws and regulations.
9. Renesas Electronics products and technologies shall not be used for or incorporated into any products or systems whose manufacture, use, or sale is prohibited under any applicable domestic or foreign laws or regulations. You shall comply with any applicable export control laws and regulations promulgated and administered by the governments of any countries asserting jurisdiction over the parties or transactions.
10. It is the responsibility of the buyer or distributor of Renesas Electronics products, or any other party who distributes, disposes of, or otherwise sells or transfers the product to a third party, to notify such third party in advance of the contents and conditions set forth in this document.
11. This document shall not be reprinted, reproduced or duplicated in any form, in whole or in part, without prior written consent of Renesas Electronics.
12. Please contact a Renesas Electronics sales office if you have any questions regarding the information contained in this document or Renesas Electronics products.

(Note1) "Renesas Electronics" as used in this document means Renesas Electronics Corporation and also includes its directly or indirectly controlled subsidiaries.

(Note2) "Renesas Electronics product(s)" means any product developed or manufactured by or for Renesas Electronics.

(Rev.4.0-1 November 2017)

## Corporate Headquarters

TOYOSU FORESIA, 3-2-24 Toyosu,  
Koto-ku, Tokyo 135-0061, Japan  
[www.renesas.com](http://www.renesas.com)

## Contact Information

For further information on a product, technology, the most up-to-date version of a document, or your nearest sales office, please visit:  
[www.renesas.com/contact/](http://www.renesas.com/contact/)

## Trademarks

Renesas and the Renesas logo are trademarks of Renesas Electronics Corporation. All trademarks and registered trademarks are the property of their respective owners.