

ISL32613E, ISL32614E

±16.5kV ESD Protected, +125°C, 1.8V to 3.6V, Low Power, SOT-23, RS-485/RS-422 Transmitters

FN7906  
Rev.4.01  
Sep 27, 2019

The [ISL32613E](#) and [ISL32614E](#) are ±16.5kV HBM ESD protected (7kV IEC61000 contact), 1.8V powered, single transmitters for differential communication. These drivers have very low bus currents (±40µA), so they present less than a 1/8 unit load to the bus. The low bus currents allow more than 256 transmitters on the network without violating the RS-485 specification's 32 unit load maximum and without using repeaters.

Hot plug circuitry ensures that the Tx outputs remain in a high impedance state while the power supply stabilizes.

Both ICs use slew rate limited drivers, which reduce EMI and minimize reflections from improperly terminated transmission lines or unterminated stubs in multidrop and multipoint applications. The ISL32613E is more slew rate limited for data rates up to 128kbps, while the less limited ISL32614E is useful for data rates up to 256kbps.

For companion low power single RS-485 receivers, see the [ISL32610E](#) datasheet.

**Related Literature**

For a full list of related documents, visit our website:

- [ISL32613E](#) and [ISL32614E](#) device pages

**Features**

- Wide supply voltage range . . . . . 1.8V to 3.6V
- Low quiescent supply current. . . . . 80µA (max)
  - Very low shutdown supply current . . . . . 2µA (max)
- High ESD protection on RS-485 outputs . . . . ±16.5kV HBM
  - Class 3 ESD level on all other pins. . . . . >8kV HBM
- Specified for +125°C
- Hot plug - Tx outputs remain three-state during power-up
- Low Tx leakage allows >256 devices on the bus
- Slew rate limited for data rates up to 256kbps
- Current limiting and thermal shutdown for driver overload protection
- 5V tolerant logic inputs
- Pb-Free (RoHS Compliant)

**Applications**

- Industrial/process control networks
- Space-constrained systems
- Factory automation
- Building environmental control/lighting systems

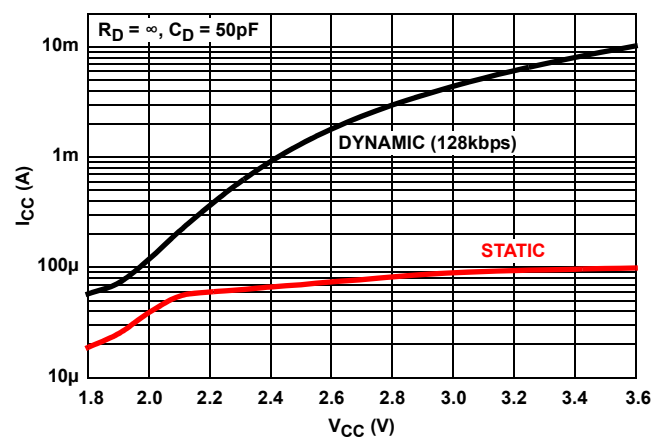

FIGURE 1. ISL32613E WITH V<sub>CC</sub> = 1.8V REDUCES OPERATING I<sub>CC</sub> BY A FACTOR OF 177 COMPARED WITH I<sub>CC</sub> AT V<sub>CC</sub> = 3.6V

**Truth Table**

TRANSMITTING			
INPUTS		OUTPUTS	
DE (Note 9)	DI	Z	Y
1	1	0	1
1	0	1	0
0	X	High-Z *	High-Z *

NOTE: \*Shutdown Mode

## Typical Operating Circuits

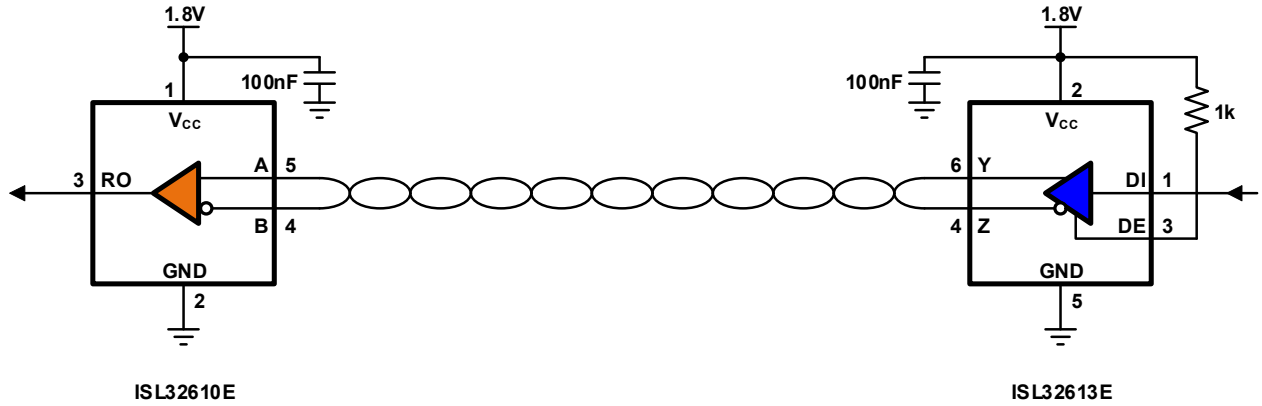

FIGURE 2. POINT-TO-POINT LINK WITH FIXED ENABLE-PINS

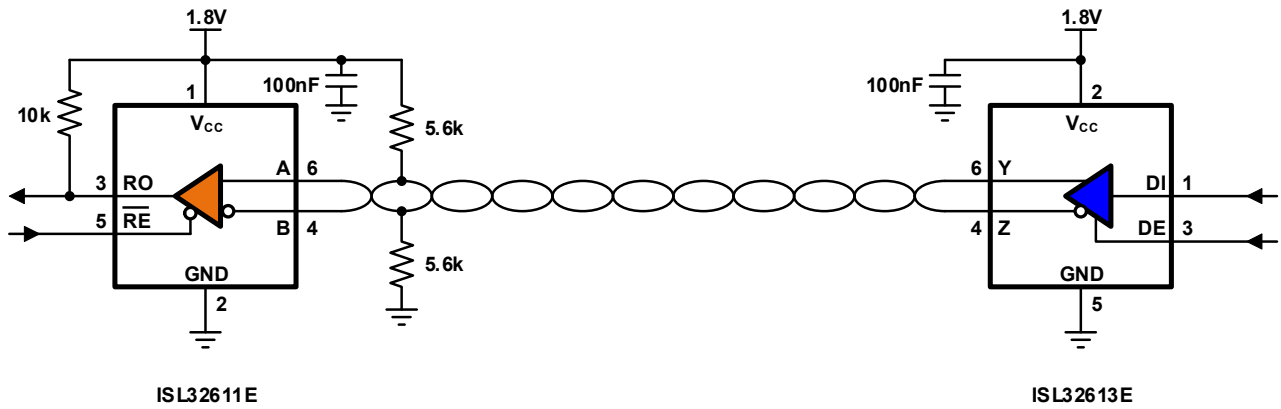

FIGURE 3. POINT-TO-POINT LINK WITH PROGRAMMABLE ENABLE-PINS

## Ordering Information

PART NUMBER (Notes 2, 3)	PART MARKING (Note 4)	TEMP RANGE (°C)	TAPE AND REEL (UNITS) (Note 1)	PACKAGE (RoHS Compliant)	PKG. DWG. #
ISL32613EFHZ-T	613F	-40 to +125	3k	6 Ld SOT-23	P6.064
ISL32613EFHZ-T7A	613F	-40 to +125	250	6 Ld SOT-23	P6.064
ISL32614EFHZ-T	614F	-40 to +125	3k	6 Ld SOT-23	P6.064
ISL32614EFHZ-T7A	614F	-40 to +125	250	6 Ld SOT-23	P6.064

## NOTES:

- See [TB347](#) for details about reel specifications.
- These Pb-free plastic packaged products employ special Pb-free material sets, molding compounds/die attach materials, and 100% matte tin plate plus anneal (e3 termination finish, which is RoHS compliant and compatible with both SnPb and Pb-free soldering operations). Pb-free products are MSL classified at Pb-free peak reflow temperatures that meet or exceed the Pb-free requirements of IPC/JEDEC J STD-020.
- For Moisture Sensitivity Level (MSL), see the [ISL32613E](#) and [ISL32614E](#) device pages. For more information about MSL, see [TB363](#).
- SOT-23 "PART MARKING" is branded on the bottom side.

## NOTES:

TABLE 1. SUMMARY OF FEATURES AT  $V_{CC} = 1.8V$ 

PART NUMBER	FUNCTION	DATA RATE (kbps)	SLEW-RATE LIMITED?	HOT PLUG?	TX ENABLED? (Note 9)	MAXIMUM QUIESCENT $I_{CC}$ ( $\mu A$ )	LOW POWER SHUTDOWN?	PIN COUNT
ISL32613E	1 Tx	128	Yes	Yes	Yes	80	Yes	6 Ld SOT
ISL32614E	1 Tx	256	Yes	Yes	Yes	80	Yes	6 Ld SOT

## Pin Configuration

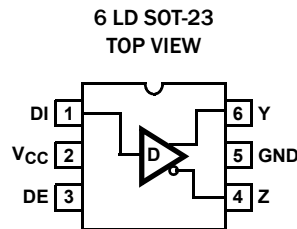

## Pin Descriptions

PIN #	PIN NAME	FUNCTION
1	DI	Driver input. A low on DI forces output Y low and output Z high. Similarly, a high on DI forces output Y high and output Z low.
2	$V_{CC}$	System power supply input (1.8V to 3.6V).
3	DE	Driver output enable. The driver outputs, Y and Z, are enabled by bringing DE high, and are high impedance when DE is low. If the driver enable function is not needed, connect DE to $V_{CC}$ through a 1k $\Omega$ to 2k $\Omega$ resistor.
4	Z	$\pm 16.5kV$ HBM, $\pm 7kV$ IEC61000 (contact method) ESD protected inverting differential transmitter output.
5	GND	Ground connection.
6	Y	$\pm 16.5kV$ HBM, $\pm 7kV$ IEC61000 (contact method) ESD protected noninverting differential transmitter output.

**Absolute Maximum Ratings**

V <sub>CC</sub> to GND	-0.3V to 7V
Input Voltages	
DI, DE	-0.3V to 7V
Output Voltages	
Y, Z (V <sub>CC</sub> = 0V or ≥ 2.7V)	-8V to +13V
Y, Z (V <sub>CC</sub> = 1.8V, Output Enabled)	-8V to +3V
Y, Z (V <sub>CC</sub> = 1.8V, Output Disabled)	-8V to +8V
Short Circuit Duration	
Y, Z	Indefinite
ESD Rating	see <a href="#">"ESD PERFORMANCE"</a>
Latch-Up (per JESD78, Level 2, Class A)	+125°C

**Thermal Information**

Thermal Resistance (Typical)	$\theta_{JA}$ (°C/W)	$\theta_{JC}$ (°C/W)
6 Ld SOT-23 Package ( <a href="#">Notes 5, 6</a> )	177	95
Maximum Junction Temperature (Plastic Package)	+150°C	
Maximum Storage Temperature Range	-65°C to +150°C	
Pb-Free Reflow Profile	see <a href="#">TB493</a>	

**Recommended Operating Conditions**

Supply Voltage Range	1.8V to 3.3V
Common-Mode Range; V <sub>CC</sub> = 1.8V	±2V
V <sub>CC</sub> ≥ 2.7V	-7V to +12V
Temperature Range (F Suffix)	-40°C to +125°C
Differential Load (R <sub>D</sub> ); V <sub>CC</sub> = 1.8V	≥10kΩ
V <sub>CC</sub> ≥ 2.7V	≥60Ω

CAUTION: Do not operate at or near the maximum ratings listed for extended periods of time. Exposure to such conditions can adversely impact product reliability and result in failures not covered by warranty.

**NOTES:**

- $\theta_{JA}$  is measured with the component mounted on a high-effective thermal conductivity test board in free air. See [TB379](#) for details.
- For  $\theta_{JC}$ , the "case temp" location is taken at the package top center.

**Electrical Specifications** V<sub>CC</sub> = 1.8V; typical values are at T<sub>A</sub> = +25°C; unless otherwise specified. **Boldface limits apply across the operating temperature range.** ([Note 7](#))

PARAMETER	SYMBOL	TEST CONDITIONS	TEMP (°C)	MIN ( <a href="#">Note 10</a> )	TYP	MAX ( <a href="#">Note 10</a> )	UNIT	
<b>DC CHARACTERISTICS</b>								
Driver Differential V <sub>OUT</sub>	V <sub>OD</sub>	R <sub>L</sub> = 100Ω ( <a href="#">Figure 4</a> )	V <sub>CC</sub> = 1.8V	Full	<b>0.8</b>	0.92	-	V
			V <sub>CC</sub> ≥ 3.15V	Full	<b>2</b>	-	-	V
		R <sub>L</sub> = 54Ω ( <a href="#">Figure 4</a> ), V <sub>CC</sub> ≥ 3V		Full	<b>1.5</b>	-	-	V
		No Load		Full	<b>1.1</b>	1.45	V <sub>CC</sub>	V
Change in Magnitude of Driver Differential V <sub>OUT</sub> for Complementary Output States	ΔV <sub>OD</sub>	R <sub>L</sub> = 100Ω ( <a href="#">Figure 4</a> )	Full	-	0.01	<b>0.2</b>	V	
Driver Common-Mode V <sub>OUT</sub>	V <sub>OC</sub>	R <sub>L</sub> = 100Ω ( <a href="#">Figure 4</a> )	Full	-	1.1	<b>1.4</b>	V	
Change in Magnitude of Driver Common-Mode V <sub>OUT</sub> for Complementary Output States	ΔV <sub>OC</sub>	R <sub>L</sub> = 100Ω ( <a href="#">Figure 4</a> )	Full	-	0.01	<b>0.2</b>	V	
Logic Input High Voltage (DI, DE)	V <sub>IH</sub>	V <sub>CC</sub> = 1.8V	Full	<b>1.26</b>	-	-	V	
		2.7V ≤ V <sub>CC</sub> ≤ 3.6V	Full	<b>2.2</b>	-	-	V	
Logic Input Low Voltage (DI, DE)	V <sub>IL</sub>	V <sub>CC</sub> = 1.8V	Full	-	-	<b>0.4</b>	V	
		2.7V ≤ V <sub>CC</sub> ≤ 3.6V	Full	-	-	<b>0.8</b>	V	
Logic Input Current	I <sub>IN</sub>	DI = DE = 0V or V <sub>CC</sub> ( <a href="#">Note 9</a> )	Full	<b>-2</b>	-	<b>2</b>	μA	
Output Leakage Current (Y, Z, <a href="#">Note 9</a> )	I <sub>OZ</sub>	DE = 0V, V <sub>CC</sub> = 0V or 1.8V, or 3.6V	V <sub>O</sub> = 7V at V <sub>CC</sub> = 1.8V	Full	-	0.1	<b>30</b>	μA
			V <sub>O</sub> = 12V at V <sub>CC</sub> = 3.6V	Full	-	0.1	<b>40</b>	μA
			V <sub>O</sub> = -7V	Full	<b>-40</b>	-8	-	μA
Driver Short-Circuit Current, V <sub>O</sub> = High or Low ( <a href="#">Note 8</a> )	I <sub>OS</sub>	V <sub>CC</sub> = 1.8V, DE = V <sub>CC</sub> , -2V ≤ V <sub>O</sub> ≤ 2V	Full	-	-	<b>±250</b>	mA	
		V <sub>CC</sub> ≥ 2.7V, DE = V <sub>CC</sub> , -7V ≤ V <sub>O</sub> ≤ 12V	Full	-	±150	-	mA	
<b>SUPPLY CURRENT</b>								
No-Load Supply Current	I <sub>CC</sub>	DE = V <sub>CC</sub> = 1.8V, DI = 0V or V <sub>CC</sub>	Full	-	20	<b>80</b>	μA	
		DE = V <sub>CC</sub> , 2.7V ≤ V <sub>CC</sub> ≤ 3.6V, DI = 0V or V <sub>CC</sub>	Full	-	100	<b>150</b>	μA	

**Electrical Specifications**  $V_{CC} = 1.8V$ ; typical values are at  $T_A = +25^\circ C$ ; unless otherwise specified. **Boldface limits apply across the operating temperature range. (Note 7) (Continued)**

PARAMETER	SYMBOL	TEST CONDITIONS	TEMP (°C)	MIN (Note 10)	TYP	MAX (Note 10)	UNIT	
Shutdown Supply Current	$I_{SHDN}$	$1.8V \leq V_{CC} \leq 3.6V$ , DE = 0V, DI = 0V or $V_{CC}$	Full	-	0.01	<b>2</b>	$\mu A$	
<b>ESD PERFORMANCE</b>								
RS-485 Pins (Y, Z)		Human Body Model, from bus pins to GND	25	-	$\pm 16.5$	-	kV	
		IEC61000 Contact, from bus pins to GND	25	-	$\pm 7$	-	kV	
All Pins		HBM, per MIL-STD-883 Method 3015	25	-	$\pm 8$	-	kV	
		Machine Model	25	-	$\pm 400$	-	V	
<b>DRIVER SWITCHING CHARACTERISTICS (ISL32613E, 128kbps Version)</b>								
Maximum Data Rate	$f_{MAX}$		$V_{CC} = 1.8V$	Full	<b>128</b>	-	-	kbps
			$3V \leq V_{CC} \leq 3.6V$	Full	<b>256</b>	-	-	kbps
Driver Differential Output Delay	$t_{DD}$	$C_D = 50pF$ (Figure 5)	$V_{CC} = 1.8V$	Full	-	1700	<b>2600</b>	ns
			$3V \leq V_{CC} \leq 3.6V$	Full	-	1100	<b>1500</b>	ns
Driver Differential Output Skew	$t_{DSK}$	$C_D = 50pF$ (Figure 5)	$V_{CC} = 1.8V$	Full	-	30	<b>200</b>	ns
			$3V \leq V_{CC} \leq 3.6V$	Full	-	2	<b>30</b>	ns
Driver Differential Rise or Fall Time	$t_R, t_F$	$C_D = 50pF$ (Figure 5)	$V_{CC} = 1.8V$	Full	-	1600	<b>2600</b>	ns
			$3V \leq V_{CC} \leq 3.6V$	Full	<b>400</b>	960	<b>1500</b>	ns
Driver Enable to Output High	$t_{ZH}$	$R_L = 500\Omega$ , $C_L = 50pF$ , SW = GND (Figure 6)	Full	-	460	<b>800</b>	ns	
Driver Enable to Output Low	$t_{ZL}$	$R_L = 500\Omega$ , $C_L = 50pF$ , SW = $V_{CC}$ (Figure 6)	Full	-	460	<b>800</b>	ns	
Driver Disable from Output High	$t_{HZ}$	$R_L = 500\Omega$ , $C_L = 50pF$ , SW = GND (Figure 6)	Full	-	60	<b>250</b>	ns	
Driver Disable from Output Low	$t_{LZ}$	$R_L = 500\Omega$ , $C_L = 50pF$ , SW = $V_{CC}$ (Figure 6)	Full	-	60	<b>250</b>	ns	
<b>DRIVER SWITCHING CHARACTERISTICS (ISL32614E, 256kbps Version)</b>								
Maximum Data Rate	$f_{MAX}$	$R_D = \infty$ , $C_D = 50pF$	$V_{CC} = 1.8V$	Full	<b>256</b>	-	-	kbps
			$3V \leq V_{CC} \leq 3.6V$	Full	<b>500</b>	-	-	kbps
Driver Differential Output Delay	$t_{DD}$	$R_D = \infty$ , $C_D = 50pF$ (Figure 5)	$V_{CC} = 1.8V$	Full	-	700	<b>2000</b>	ns
			$3V \leq V_{CC} \leq 3.6V$	Full	-	350	<b>500</b>	ns
Driver Differential Output Skew	$t_{DSK}$	$R_D = \infty$ , $C_D = 50pF$ (Figure 5)	$V_{CC} = 1.8V$	Full	-	30	<b>200</b>	ns
			$3V \leq V_{CC} \leq 3.6V$	Full	-	2	<b>30</b>	ns
Driver Differential Rise or Fall Time	$t_R, t_F$	$R_D = \infty$ , $C_D = 50pF$ (Figure 5)	$V_{CC} = 1.8V$	Full	-	1700	<b>2600</b>	ns
			$3V \leq V_{CC} \leq 3.6V$	Full	<b>200</b>	350	<b>800</b>	ns
Driver Enable to Output High	$t_{ZH}$	$R_L = 500\Omega$ , $C_L = 50pF$ , SW = GND (Figure 6)	Full	-	460	<b>800</b>	ns	
Driver Enable to Output Low	$t_{ZL}$	$R_L = 500\Omega$ , $C_L = 50pF$ , SW = $V_{CC}$ (Figure 6)	Full	-	460	<b>800</b>	ns	
Driver Disable from Output High	$t_{HZ}$	$R_L = 500\Omega$ , $C_L = 50pF$ , SW = GND (Figure 6)	Full	-	60	<b>250</b>	ns	
Driver Disable from Output Low	$t_{LZ}$	$R_L = 500\Omega$ , $C_L = 50pF$ , SW = $V_{CC}$ (Figure 6)	Full	-	60	<b>250</b>	ns	

**NOTES:**

- All currents into device pins are positive; all currents out of device pins are negative. All voltages are referenced to device ground unless otherwise specified.
- Applies to peak current. See "[Typical Performance Curves](#)" on page 7 for more information.
- If the Driver Enable function is not needed, connect DE to  $V_{CC}$  through a 1k $\Omega$  to 2k $\Omega$  resistor.
- Compliance to datasheet limits is assured by one or more methods: production test, characterization, and/or design.

# Test Circuits and Waveforms

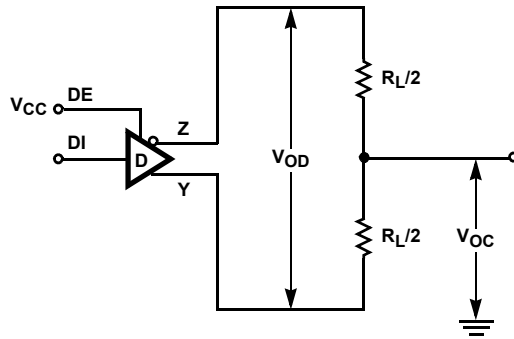

FIGURE 4. DC DRIVER TEST CIRCUITS

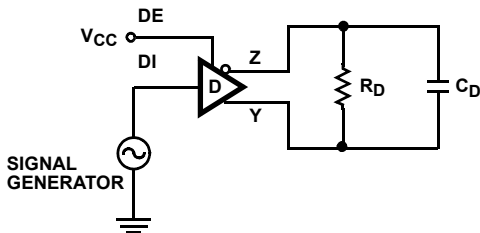
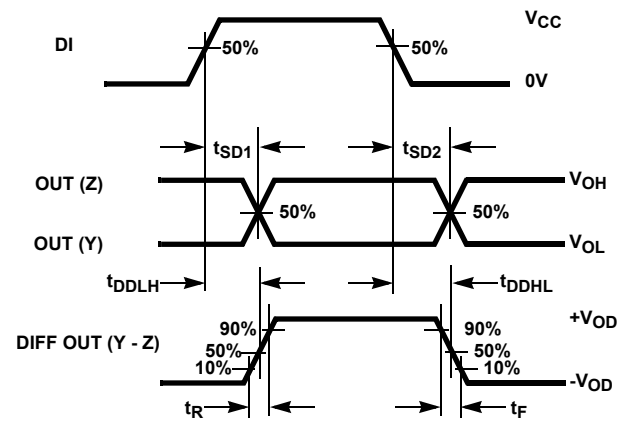

FIGURE 5A. TEST CIRCUIT



$$t_{SSK} = |t_{SD1(Y)} - t_{SD2(Y)}| \text{ OR } |t_{SD1(Z)} - t_{SD2(Z)}| \quad t_{DSK} = |t_{DDLH} - t_{DDHL}|$$

FIGURE 5B. MEASUREMENT POINTS

FIGURE 5. DRIVER PROPAGATION DELAY AND DIFFERENTIAL TRANSITION TIMES

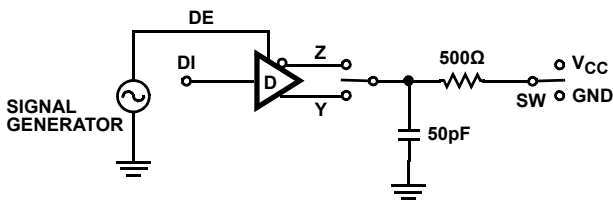

PARAMETER	OUTPUT	DI	SW
$t_{HZ}$	Y/Z	1/0	GND
$t_{LZ}$	Y/Z	0/1	$V_{CC}$
$t_{zH}$	Y/Z	1/0	GND
$t_{zL}$	Y/Z	0/1	$V_{CC}$

FIGURE 6A. TEST CIRCUIT

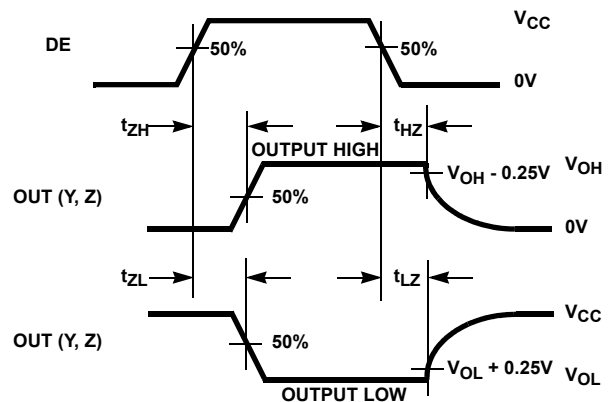

FIGURE 6B. MEASUREMENT POINTS

FIGURE 6. DRIVER ENABLE AND DISABLE TIMES

# Typical Performance Curves $V_{CC} = 1.8V, T_A = +25^\circ C$ ; unless otherwise specified.

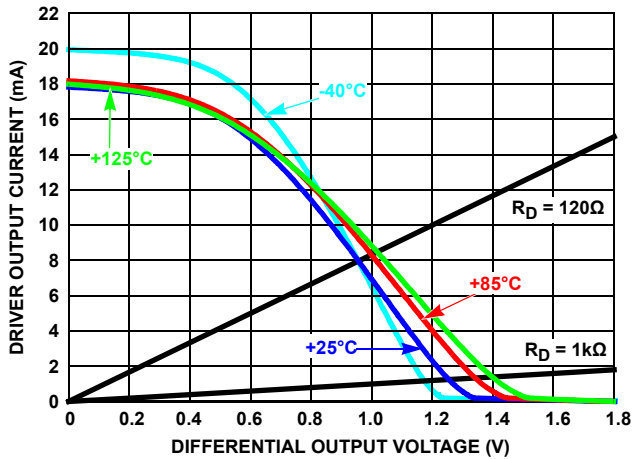

FIGURE 7. DRIVER OUTPUT CURRENT vs DIFFERENTIAL OUTPUT VOLTAGE

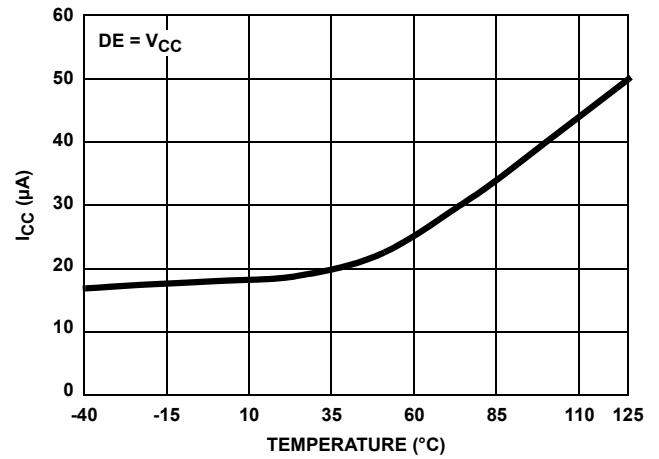

FIGURE 8. STATIC SUPPLY CURRENT vs TEMPERATURE

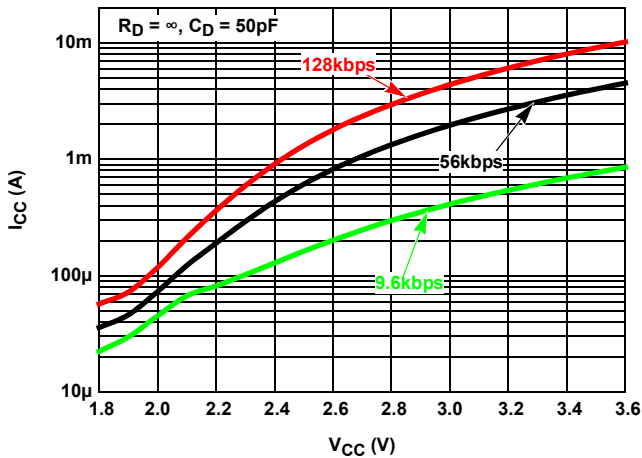

FIGURE 9. ISL32613E DYNAMIC SUPPLY CURRENT vs SUPPLY VOLTAGE AT DIFFERENT DATA RATES

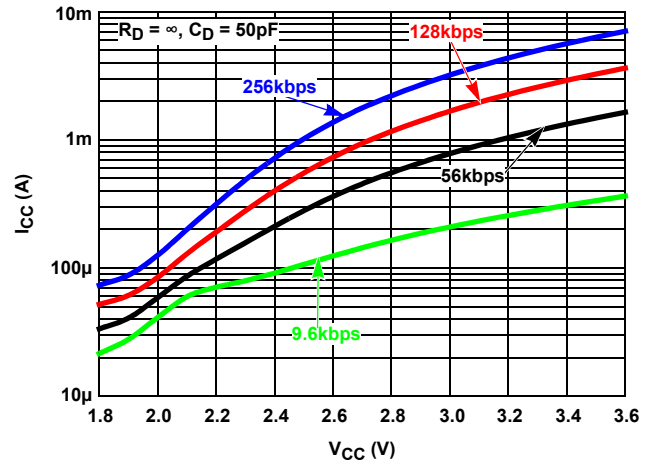

FIGURE 10. ISL32614E DYNAMIC SUPPLY CURRENT vs SUPPLY VOLTAGE AT DIFFERENT DATA RATES

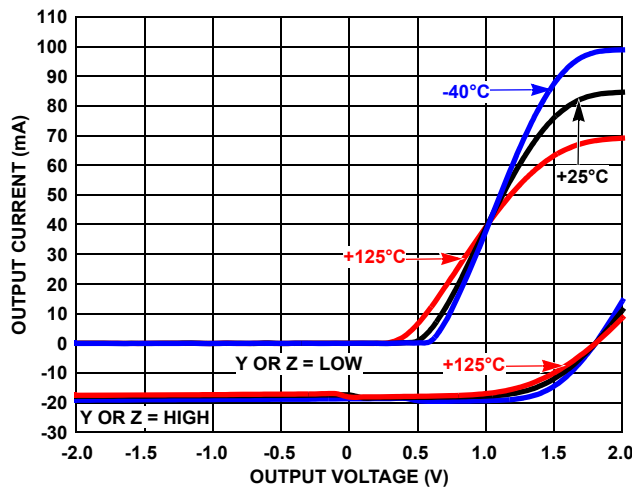

FIGURE 11. DRIVER OUTPUT CURRENT vs SHORT-CIRCUIT VOLTAGE

**Typical Performance Curves**  $V_{CC} = 1.8V, T_A = +25^\circ C$ ; unless otherwise specified. (Continued)

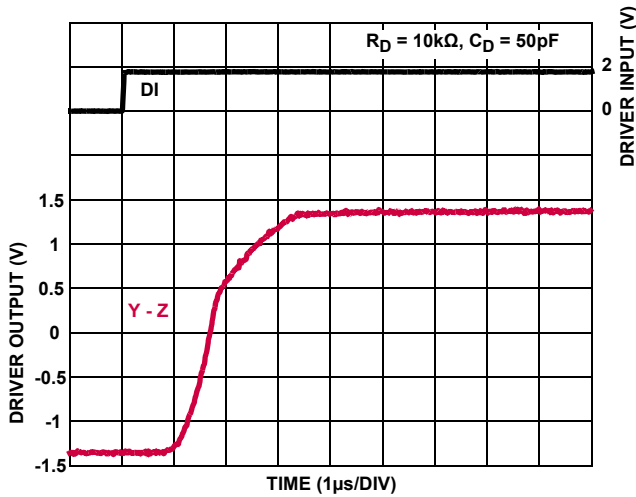

FIGURE 12. ISL32613E DRIVER WAVEFORMS, LOW-TO-HIGH

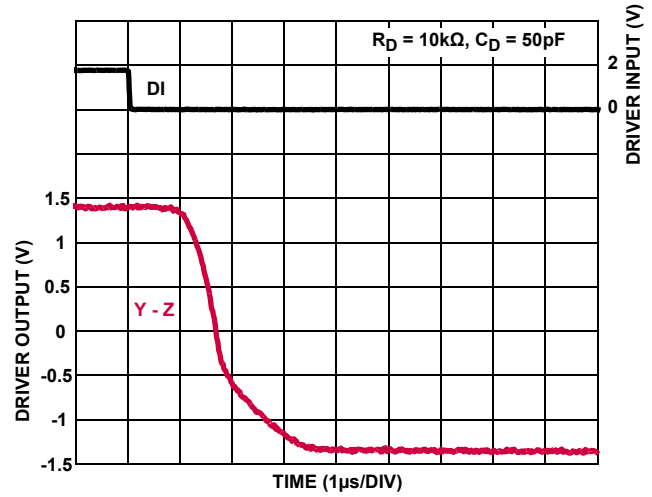

FIGURE 13. ISL32614E DRIVER WAVEFORMS, HIGH-TO-LOW

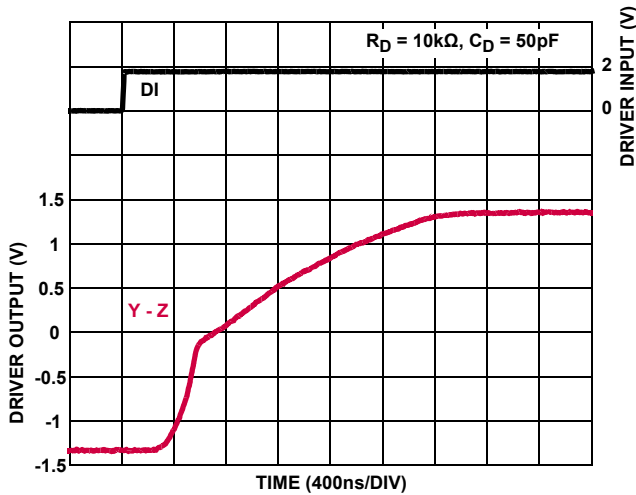

FIGURE 14. ISL32614E DRIVER WAVEFORMS, LOW-TO-HIGH

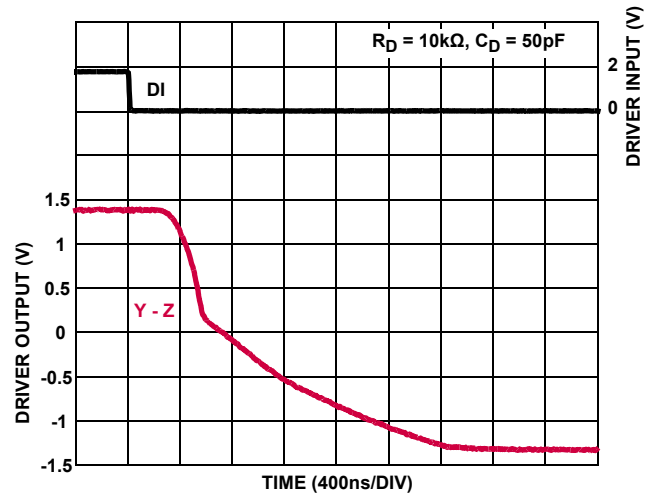

FIGURE 15. ISL32614E DRIVER WAVEFORMS, HIGH-TO-LOW

**Application Information**

**Driver Features**

The ISL32613E and ISL32614E transmitters are differential output devices that operate with  $V_{CC}$  as low as 1.8V and up to 3.6V. The devices are RS-485 compliant with  $V_{CC} \geq 3V$ , but significant power savings are obtained by operating at  $V_{CC} = 1.8V$ .

The transmitter outputs are tri-statable with the active high DE input. If the Tx enable function is not needed, tie DE to  $V_{CC}$  through a 1kΩ to 2kΩ resistor. Outputs are slew rate limited to minimize EMI and to reduce reflections in unterminated or improperly terminated networks.

**1.8V Operation**

The ISL32613E and ISL32614E operate with  $V_{CC}$  as low as 1.8V. When coupled with the ISL32610E or ISL32611E 1.8V receivers, they provide a differential communication link optimized for very low power and for slow data rates. Figures 9 and 10 illustrate the static and dynamic power savings from using these transmitters at low supply voltages. With  $V_{CC} = 1.8V$  rather than 3.3V, using the ISL32613E at 128kbps reduces the operating supply current from 9.9mA to 56μA (a factor of 177).

**5.5V Tolerant Logic Pins**

The logic input pins (DI and DE) contain no ESD or parasitic diodes to  $V_{CC}$ , so they withstand input voltages exceeding 5.5V, regardless of the  $V_{CC}$  voltage.



## Hot Plug Function

When a piece of equipment powers up, there is a period of time during when the processor or ASIC driving the RS-485 control line (DE) is unable to ensure that the RS-485 Tx outputs are kept disabled. If the equipment is connected to the bus, a driver activating prematurely during power-up may crash the bus. To avoid crashes, these transmitters incorporate a hot plug function. During power-up, circuitry monitoring  $V_{CC}$  ensures that the Tx outputs remain disabled for a period of time, regardless of the state of DE. The disabled Tx outputs allow the processor/ASIC a chance to stabilize and drive the control lines to the proper states.

## ESD Protection

All pins on these devices include Class 3 (8kV) Human Body Model (HBM) ESD protection structures, but the driver outputs incorporate advanced structures that allow them to survive ESD events in excess of  $\pm 16.5\text{kV}$  HBM and  $\pm 7\text{kV}$  to the IEC61000 contact test method. The RS-485 pins are particularly vulnerable to ESD damage because they typically connect to an exposed port on the exterior of the finished product. Touching the port pins or connecting a cable can cause an ESD event that destroy unprotected ICs. The new ESD structures protect the device whether it is powered up or not, and without degrading the common-mode range. This built-in ESD protection eliminates the need for board-level protection structures (for example, transient suppression diodes) and the associated, undesirable capacitive load they present.

## Driver Overload Protection

The driver output stages incorporate short-circuit, current-limiting circuitry that ensures that the output current never exceeds the RS-485 specification over a  $\pm 2\text{V}$  ( $-7\text{V}$  to  $+12\text{V}$  for  $V_{CC} \geq 2.7\text{V}$ ) common mode voltage range.

The ISL32613E and ISL32614E's thermal shutdown feature disables the drivers whenever the die temperature becomes excessive in the event of a major short-circuit condition. Thermal shutdown eliminates power dissipation, allowing the die to cool. The drivers automatically reenables after the die temperature drops by about  $+20^\circ\text{C}$ . If the condition persists, the thermal shutdown/reenable cycle repeats until the fault is cleared.

## Low Power Shutdown Mode

Th BiCMOS transmitters use a fraction of the power required by its bipolar counterparts, but they also include a shutdown feature that reduces the already low quiescent  $I_{CC}$  to a 10nA trickle. These devices enter shutdown whenever the driver disables (DE = GND).

## Die Characteristics

### SUBSTRATE POTENTIAL (POWERED UP):

GND

### PROCESS:

Si Gate BiCMOS

## Revision History

The revision history provided is for informational purposes only and is believed to be accurate, but not warranted. Please visit our website to ensure you have the latest revision.

DATE	REVISION	CHANGE
Sep 27, 2019	FN7906.4.01	Replaced Figures 2 and 3. Removed Note on page 2.
Feb 14, 2019	FN7906.4	Updated both Typical Operating Circuits. Updated links throughout document. Updated disclaimer.
Jun 12, 2018	FN7906.3	Added Related Literature section on page 1. Updated Ordering information table by switching Notes 1 and 2 and adding the tape and reel units column. Removed military temperature range from Features on page 1. Removed 55 °C curves from Figures 7 and 11 on page 8. Removed About Intersil section and added Renesas disclaimer.
Jul 27, 2015	FN7906.2	Ordering Information Table on page 3: Removed part numbers ISL32614EMHZ-T and ISL32614EMHZ-T7A. Recommended Operating Conditions table on page 4: Removed the line referencing "M Suffix". Replaced "Product" section with "About Intersil" on page 10.
May 2, 2012	FN7906.1	Page 1, "Features" - changed "Specified for +125 °C Operation" to "Specified for +125 °C or Full Mil Temperature Operation". Also changed Figure 1 title. Page 2, added new part "ISL32614EMHZ-T" to the "Ordering Information". Page 4, changed "Y, Z (V <sub>CC</sub> = 1.8V)" to "Y, Z (V <sub>CC</sub> = 1.8V, Output Enabled)" and added "Y, Z (V <sub>CC</sub> = 1.8V, Output Disabled)... -8V to +8V" under the "Absolute Maximum Rating". Also added "(F Suffix)" and "(M Suffix)...-55 °C to +125 °C" under the "Recommended Operating Conditions". Page 8, replaced Figure 7 and added -55 °C curve to Figure 11 under the "Typical Performance Curves".
Aug 30, 2011	FN7906.0	Initial Release

# Package Outline Drawing

For the most recent package outline drawing, see [P6.064](#).

## P6.064

6 LEAD SMALL OUTLINE TRANSISTOR PLASTIC PACKAGE

Rev 4, 2/10

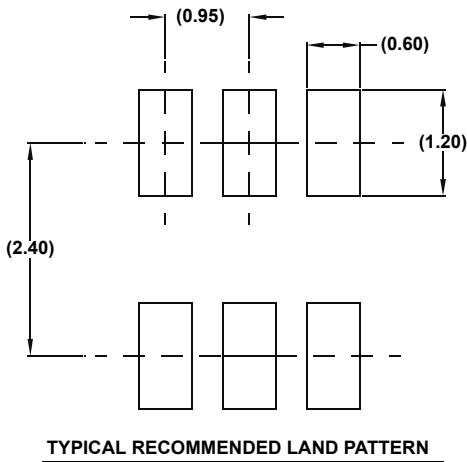
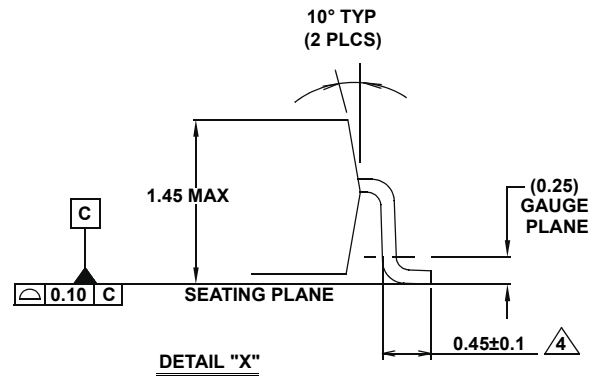
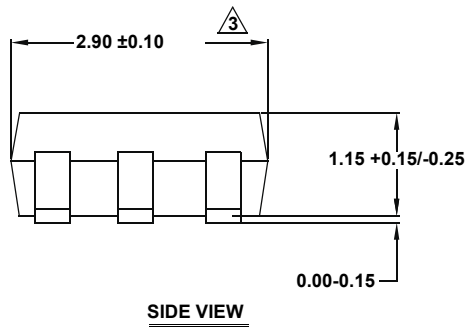
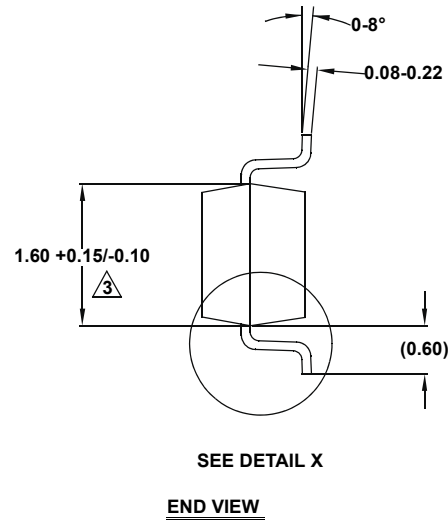
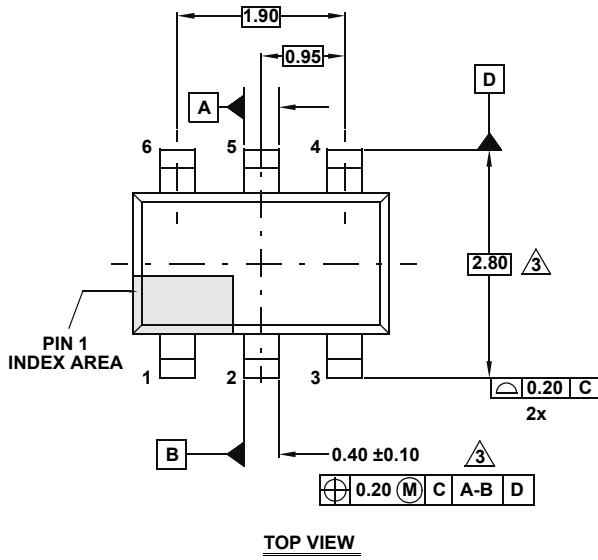

**NOTES:**

1. Dimensions are in millimeters.  
Dimensions in ( ) for Reference Only.
2. Dimensioning and tolerancing conform to ASME Y14.5M-1994.
3. Dimension is exclusive of mold flash, protrusions or gate burrs.
4. Foot length is measured at reference to gauge plane.
5. Package conforms to JEDEC MO-178AB.

## Notice

1. Descriptions of circuits, software and other related information in this document are provided only to illustrate the operation of semiconductor products and application examples. You are fully responsible for the incorporation or any other use of the circuits, software, and information in the design of your product or system. Renesas Electronics disclaims any and all liability for any losses and damages incurred by you or third parties arising from the use of these circuits, software, or information.
  2. Renesas Electronics hereby expressly disclaims any warranties against and liability for infringement or any other claims involving patents, copyrights, or other intellectual property rights of third parties, by or arising from the use of Renesas Electronics products or technical information described in this document, including but not limited to, the product data, drawings, charts, programs, algorithms, and application examples.
  3. No license, express, implied or otherwise, is granted hereby under any patents, copyrights or other intellectual property rights of Renesas Electronics or others.
  4. You shall not alter, modify, copy, or reverse engineer any Renesas Electronics product, whether in whole or in part. Renesas Electronics disclaims any and all liability for any losses or damages incurred by you or third parties arising from such alteration, modification, copying or reverse engineering.
  5. Renesas Electronics products are classified according to the following two quality grades: "Standard" and "High Quality". The intended applications for each Renesas Electronics product depends on the product's quality grade, as indicated below.
    - "Standard": Computers; office equipment; communications equipment; test and measurement equipment; audio and visual equipment; home electronic appliances; machine tools; personal electronic equipment; industrial robots; etc.
    - "High Quality": Transportation equipment (automobiles, trains, ships, etc.); traffic control (traffic lights); large-scale communication equipment; key financial terminal systems; safety control equipment; etc.Unless expressly designated as a high reliability product or a product for harsh environments in a Renesas Electronics data sheet or other Renesas Electronics document, Renesas Electronics products are not intended or authorized for use in products or systems that may pose a direct threat to human life or bodily injury (artificial life support devices or systems; surgical implantations; etc.), or may cause serious property damage (space system; undersea repeaters; nuclear power control systems; aircraft control systems; key plant systems; military equipment; etc.). Renesas Electronics disclaims any and all liability for any damages or losses incurred by you or any third parties arising from the use of any Renesas Electronics product that is inconsistent with any Renesas Electronics data sheet, user's manual or other Renesas Electronics document.
  6. When using Renesas Electronics products, refer to the latest product information (data sheets, user's manuals, application notes, "General Notes for Handling and Using Semiconductor Devices" in the reliability handbook, etc.), and ensure that usage conditions are within the ranges specified by Renesas Electronics with respect to maximum ratings, operating power supply voltage range, heat dissipation characteristics, installation, etc. Renesas Electronics disclaims any and all liability for any malfunctions, failure or accident arising out of the use of Renesas Electronics products outside of such specified ranges.
  7. Although Renesas Electronics endeavors to improve the quality and reliability of Renesas Electronics products, semiconductor products have specific characteristics, such as the occurrence of failure at a certain rate and malfunctions under certain use conditions. Unless designated as a high reliability product or a product for harsh environments in a Renesas Electronics data sheet or other Renesas Electronics document, Renesas Electronics products are not subject to radiation resistance design. You are responsible for implementing safety measures to guard against the possibility of bodily injury, injury or damage caused by fire, and/or danger to the public in the event of a failure or malfunction of Renesas Electronics products, such as safety design for hardware and software, including but not limited to redundancy, fire control and malfunction prevention, appropriate treatment for aging degradation or any other appropriate measures. Because the evaluation of microcomputer software alone is very difficult and impractical, you are responsible for evaluating the safety of the final products or systems manufactured by you.
  8. Please contact a Renesas Electronics sales office for details as to environmental matters such as the environmental compatibility of each Renesas Electronics product. You are responsible for carefully and sufficiently investigating applicable laws and regulations that regulate the inclusion or use of controlled substances, including without limitation, the EU RoHS Directive, and using Renesas Electronics products in compliance with all these applicable laws and regulations. Renesas Electronics disclaims any and all liability for damages or losses occurring as a result of your noncompliance with applicable laws and regulations.
  9. Renesas Electronics products and technologies shall not be used for or incorporated into any products or systems whose manufacture, use, or sale is prohibited under any applicable domestic or foreign laws or regulations. You shall comply with any applicable export control laws and regulations promulgated and administered by the governments of any countries asserting jurisdiction over the parties or transactions.
  10. It is the responsibility of the buyer or distributor of Renesas Electronics products, or any other party who distributes, disposes of, or otherwise sells or transfers the product to a third party, to notify such third party in advance of the contents and conditions set forth in this document.
  11. This document shall not be reprinted, reproduced or duplicated in any form, in whole or in part, without prior written consent of Renesas Electronics.
  12. Please contact a Renesas Electronics sales office if you have any questions regarding the information contained in this document or Renesas Electronics products.
- (Note1) "Renesas Electronics" as used in this document means Renesas Electronics Corporation and also includes its directly or indirectly controlled subsidiaries.
- (Note2) "Renesas Electronics product(s)" means any product developed or manufactured by or for Renesas Electronics.

(Rev.4.0-1 November 2017)

## Corporate Headquarters

TOYOSU FORESIA, 3-2-24 Toyosu,  
Koto-ku, Tokyo 135-0061, Japan  
[www.renesas.com](http://www.renesas.com)

## Contact Information

For further information on a product, technology, the most up-to-date version of a document, or your nearest sales office, please visit:  
[www.renesas.com/contact/](http://www.renesas.com/contact/)

## Trademarks

Renesas and the Renesas logo are trademarks of Renesas Electronics Corporation. All trademarks and registered trademarks are the property of their respective owners.