

ISL29147

Low Power Ambient Light and Proximity Sensor with Enhanced Infrared Rejection

FN8409
Rev 3.00
January 6, 2015

The ISL29147 is a low power Ambient Light Sensor (ALS) and proximity (PROX) sensor. It has a built-in IR-LED for the proximity function. The ALS function measures the amount of light (in the visible spectrum) incident on the ISL29147.

The ALS function has a programmable ambient IR-rejection, which allows fine tuning of light source variations and is ideal for light sensor applications under dark protective glass. The ALS provides a 12-bit measurement. A passive optical filter removes unwanted wavelengths (IR or Ultraviolet) to ensure accurate ALS measurement.

The proximity function includes a new offset adjustment to compensate for the IR light reflected off the inside of the protective glass cover and back to the ISL29147 sensor. This offset adjustment allows the sensor to compensate for these internal reflections and preserve the dynamic range of the proximity measurement.

The built-in current-driver pulses an external infrared LED at a programmed current for 90µs. The infrared light that is reflected and received by the ISL29147 is digitized by an 8-bit ADC. The proximity sensor also has a passive optical filter designed to pass IR and reject visible wavelengths.

The ISL29147 provides a hardware pin to indicate an interrupt event. The interrupt pin saves power as the host microcontroller can 'wake-up' on an interrupt event and does not need to poll the device for an interrupt event. The interrupt generator is user configurable and provides several options for ALS and PROX trigger configurations. The ISL29147 supports an SMBus compatible I²C interface for configuration and control.

Features

- Internal IR-LED and sensor for a complete solution
- Ideal for applications under dark or tinted glass
- Enhanced ambient sunlight rejection to 40k Lux
- Programmable proximity sleep time between proximity measurements optimizes power consumption
- Hardware interrupt - no polling required
- Programmable IR compensation to fine-tune ALS performance for various glass compositions
- Programmable IR LED drive current to 250mA
- Operates from 2.25V to 3.63V V_{DD}
- Power-down I_{DD}, typical 0.2µA_{DC}
- Tiny 2.40x4x1.2 (mm) optical co-package

Applications

- Display dimming and adjustment
 - Mobile devices: smart phones, PDA, GPS
 - Computing: monitors, laptops, notebooks
 - Picture frames, tablet-PCs, LCD-TV
- Object detection
 - Touchscreen disabling
 - Smart power-saving

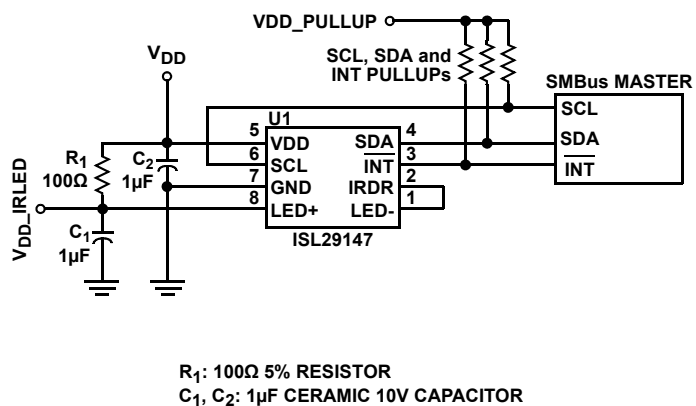

FIGURE 1. TYPICAL APPLICATIONS CIRCUIT

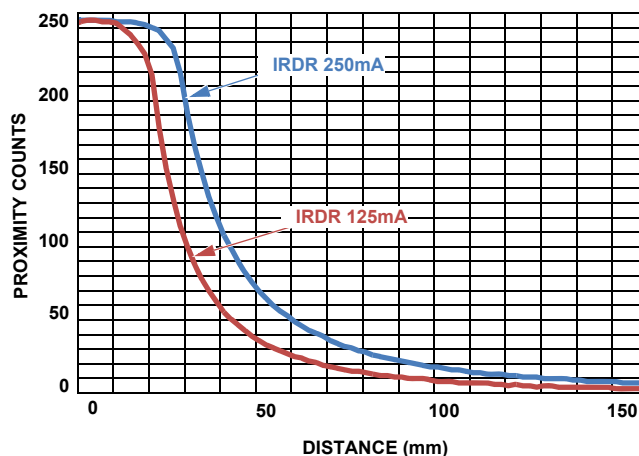
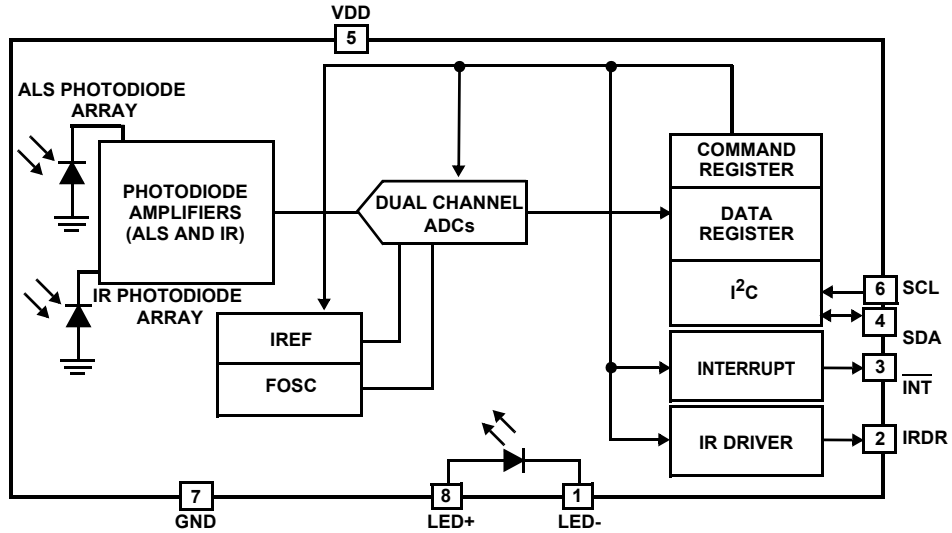

FIGURE 2. PROXIMITY SENSITIVITY

Block Diagram



Pin Configuration

ISL29147
(8 LD 2.40x4 (mm) OPTICAL CO-PACKAGE)
TOP VIEW

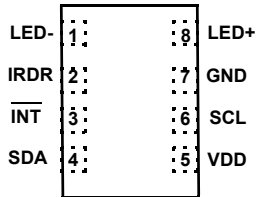

Pin Description

PIN#	NAME	DESCRIPTION
1	LED-	Cathode of IR LED.
2	IRDR	IR-LED Driver Sink - Connect to IR LED Cathode.
3	$\overline{\text{INT}}$	Active Low, Open-Drain Output.
4	SDA	I ² C Serial Data Input/Output.
5	VDD	Positive supply: 2.25V to 3.63V.
6	SCL	I ² C Serial Clock Input.
7	GND	Ground.
8	LED+	Anode of IR LED.

Ordering Information

PART NUMBER (Notes 1, 2, 3)	PART MARKING	V _{DD} RANGE (V)	TEMP RANGE (°C)	PACKAGE (RoHS Compliant)	PKG. DWG. #
ISL29147IROMZ-T7	N/A	2.25 to 3.63	-40 to +85	8 Ld Optical Co-package	LS.2.40x4
ISL29147IROMZ-EVALZ	Evaluation Board				

NOTES:

1. Please refer to [TB347](#) for details on reel specifications.
2. These Intersil Pb-free plastic packaged products employ special Pb-free material sets; molding compounds/die attach materials and NiPdAu plate - e4 termination finish, which is RoHS compliant and compatible with both SnPb and Pb-free soldering operations. Intersil Pb-free products are MSL classified at Pb-free peak reflow temperatures that meet or exceed the Pb-free requirements of IPC/JEDEC J STD-020.
3. For Moisture Sensitivity Level (MSL), please see product information page for [ISL29147](#). For more information on MSL, please see tech brief [TB363](#).

Absolute Maximum Ratings

V _{DD} Supply Voltage between VDD and GND	4.0V
I ² C Bus Pin Voltage (SCL, SDA)	-0.5V to 4.0V
I ² C Bus Pin Current (SCL, SDA)	<10mA
INT Pin Voltage	-0.5V to 4.0V
INT Pin Current	<10mA
ESD Rating	
Human Body Model (Tested per JESD22-A114E) (Note 4)	2kV

Thermal Information

Thermal Resistance (Typical)	θ_{JA} (°C/W)
8 Ld Optical Co-package (Note 5)	425
Maximum Die Temperature	+90°C
Storage Temperature	-40°C to +85°C
Operating Temperature	-40°C to +85°C
Pb-Free Reflow Profile (*)	see TB487
*Peak temperature during solder reflow +235°C max	

CAUTION: Do not operate at or near the maximum ratings listed for extended periods of time. Exposure to such conditions may adversely impact product reliability and result in failures not covered by warranty.

NOTES:

- ESD on all pins is 2kV except IRDR, which is 1.5kV.
- θ_{JA} is measured in free air with the component mounted on a high effective thermal conductivity test board with "direct attach" features. See Tech Brief [TB379](#).

Electrical Specifications $V_{DD} = 3.0V, T_A = +25^\circ C$.

PARAMETER	DESCRIPTION	TEST CONDITION	MIN (Note 10)	TYP	MAX (Note 10)	UNITS
INPUT POWER						
V _{DD}	Power Supply Range		2.25	3.0	3.63	V
I _{DD_OFF}	Supply Current when Powered Down	ALS_EN = 0; PROX_EN = 0		0.2	1.0	μA
I _{DD_NORM}	Supply Current for ALS+Prox in Sleep Time	ALS_EN = 1; PROX_EN = 1		125	140	μA
I _{DD_PRX_SLP}	Supply Current for Prox in Sleep Time	ALS_EN = 0; PROX_EN = 1		95		μA
I _{DD_ALS}	Supply Current for ALS	ALS_EN = 1; PROX_EN = 0		95		μA
ADC (ALS and PROX)						
t _{INTGR_ALS}	12-bit ALS Conversion Time		80	95	110	ms
t _{INTGR_PROX}	8-bit Prox Conversion Time		0.4	0.50	0.6	ms
DATA _{ALS_0}	ALS Result when Dark	E _{AMBIENT} = 0 Lux, 900 Lux range		1		Counts
DATA _{ALS_F}	Full Scale ALS ADC Code	E _{AMBIENT} > selected range maximum Lux			4095	Counts
$\frac{\Delta DATA_1}{DATA}$	Output Variation Over Light Sources: Fluorescent, Incandescent and Sunlight	Ambient light sensing, no cover glass After programmable active IR compensation (Note 6)		±10		%
$\frac{\Delta DATA_2}{DATA}$	Output Variation Over Light Sources: Fluorescent, Incandescent and Sunlight	Ambient light sensing under cover glass After programmable active IR compensation (Note 6)		±10		%
Linearity	ALS ADC Data Linearity	20% - 80% of full range		±5		%
DATA _{PROX_0}	Prox Data without Object in Path			1		Counts
DATA _{PROX_F}	Full Scale Prox ADC Code				255	Counts
ProxWASH	Washout Bit Activation Level	Norwood Solar Emulator		40k		Lux
ProxOffsetMax	Maximum PROX Offset, Referenced to Proximity ADC Range			512		LSB
ProxOffsetInc	Proximity Offset Adjust Increment Referenced to Proximity ADC Range			27		LSB

Electrical Specifications $V_{DD} = 3.0V, T_A = +25^\circ C$. (Continued)

PARAMETER	DESCRIPTION	TEST CONDITION	MIN (Note 10)	TYP	MAX (Note 10)	UNITS
LED DRIVER (IRDR PIN)						
t_r	Rise Time for IRDR Sink Current	$R_{LOAD} = 15\Omega$ at IRDR pin, 20% to 80%		25		ns
t_f	Fall time for IRDR Sink Current	$R_{LOAD} = 15\Omega$ at IRDR pin, 80% to 20%		15		ns
I_{IRDR_0}	IRDR Sink Current	PROX_DR = 0; $V_{IRDR} = 0.5V$		31.25		mA
I_{IRDR_1}	IRDR Sink Current	PROX_DR = 1; $V_{IRDR} = 0.5V$		62.5		mA
I_{IRDR_2}	IRDR Sink Current	PROX_DR = 2; $V_{IRDR} = 0.5V$		125		mA
I_{IRDR_3}	IRDR Sink Current	PROX_DR = 3; $V_{IRDR} = 0.5V$		250		mA
I_{IRDR_LEAK}	IRDR Leakage Current	PROX_EN = 0; $V_{IRDR} = 3.63V$		0.001	1	μA
V_{IRDR}	IRDR Pin Voltage Compliance	Register bit PROX_DR = 0	0.50		4.3	V
t_{PULSE}	I_{IRDR} On Time Per PROX Reading			90		μs

IR-LED Specifications $T_A = +25^\circ C$.

SYMBOL	PARAMETER	TEST CONDITIONS	MIN (Note 10)	TYP	MAX (Note 10)	UNITS
V_F	IR-LED Forward Voltage	$I_F = 100mA$		1.8		V
V_R	IR-LED Reverse Voltage				5.5	V
λ_p	IR-LED Peak Output Wavelength	$I_F = 100mA$		855		nm
$\Delta\lambda$	IR-LED Spectral Half-Width	$I_F = 100mA$		30		nm
Φ_E	IR-LED Radiant Power	$I_F = 100mA$		38		mW

I²C Electrical Specifications For SCL and SDA unless otherwise noted, $V_{DD} = 3V, T_A = +25^\circ C$ (Note 8).

SYMBOL	PARAMETER	TEST CONDITIONS	MIN (Note 10)	TYP	MAX (Note 10)	UNITS
V_{I^2C}	Supply Voltage Range for I ² C Interface		1.7		3.63	V
f_{SCL}	SCL Clock Frequency				400	kHz
V_{IL}	SCL and SDA Input Low Voltage				0.55	V
V_{IH}	SCL and SDA Input High Voltage		1.25			V
V_{hys}	Hysteresis of Schmitt Trigger Input		$0.05V_{DD}$			V
V_{OL}	Low-level Output Voltage (open-drain) at 4mA Sink Current				0.4	V
I_i	Input Leakage for each SDA, SCL Pin		-10		10	μA
t_{SP}	Pulse Width of Spikes that must be Suppressed by the Input Filter				50	ns
t_{AA}	SCL Falling Edge to SDA Output Data Valid				900	ns
C_i	Capacitance for each SDA and SCL Pin				10	pF
$t_{HD:STA}$	Hold Time START Condition	After this period, the first clock pulse is generated	600			ns
t_{LOW}	LOW Period of the SCL Clock	Measured at the 30% of V_{DD} crossing	1300			ns
t_{HIGH}	HIGH Period of the SCL Clock		600			ns
$t_{SU:STA}$	Set-up Time for a START Condition		600			ns
$t_{HD:DAT}$	Data Hold Time		30			ns

I²C Electrical Specifications

For SCL and SDA unless otherwise noted, $V_{DD} = 3V$, $T_A = +25^\circ C$ (Note 8). (Continued)

SYMBOL	PARAMETER	TEST CONDITIONS	MIN (Note 10)	TYP	MAX (Note 10)	UNITS
$t_{SU:DAT}$	Data Set-up Time		100			ns
t_R	Rise Time of both SDA and SCL Signals	(Note 9)	$20 + 0.1 \times C_b$			ns
t_F	Fall Time of both SDA and SCL Signals	(Note 9)	$20 + 0.1 \times C_b$			ns
$t_{SU:STO}$	Set-up Time for STOP Condition		600			ns
t_{BUF}	Bus Free Time Between a STOP and START Condition		1300			ns
C_b	Capacitive Load for Each Bus Line				400	pF
$R_{pull-up}$	SDA and SCL System Bus Pull-Up Resistor	Maximum determined by t_R and t_F	1			k Ω
$t_{VD:DAT}$	Data Valid Time				0.9	μs
$t_{VD:ACK}$	Data Valid Acknowledge Time				0.9	μs
V_{nL}	Noise Margin at the LOW Level		$0.1V_{DD}$			V
V_{nH}	Noise Margin at the HIGH Level		$0.2V_{DD}$			V

NOTES:

6. Cover glass assumes fixed infrared/visible light transmissivity ratio of 10.
7. An 850nm infrared LED is used in production test for proximity/IR sensitivity testing.
8. All parameters in the I²C Electrical Specifications table are guaranteed by design and simulation.
9. C_b is the capacitance of the bus in pF.
10. Parameters with MIN and/or MAX limits are 100% tested at $+25^\circ C$, unless otherwise specified. Temperature limits established by characterization and are not production tested.

ISL29147 Configuration and Control

I²C Interface

The ISL29147 configuration and control is performed using the I²C or SMBus. The ISL29147's I²C interface slave address is internally hard wired as 8'b1000100x, where x denotes the R/W bit.

Every I²C transaction begins with the master asserting a start condition (SDA falling while SCL remains high). The first transmitted byte is initiated by the master and includes 7 address bits and a R/W bit. The slave is responsible for pulling SDA low during the ACK time after every transmitted byte.

Figure 4 shows a sample one-byte read. The I²C bus master always drives the SCL (clock) line, while either the master or the slave can drive the SDA (data) line.

Each I²C transaction ends with the master asserting a stop condition (SDA rising while SCL remains high). For more information about the I²C standard, consult the Philips™ I²C specification documents.

Timing specifications are included in "[I²C Electrical Specifications](#)" on page 4. The timing parameters are defined in Figure 3.

The I²C interface on the ISL29147 supports single and multiple byte read and write transfers using the random-read/write protocol. The ISL29147 does not support I²C 'Repeat Start' protocol.

NOTE: In most system implementations, the ISL29147 is connected to a single I²C master with one or more slave devices, consequently, absence of the "Repeat Start" function does not adversely affect I²C bus system performance.

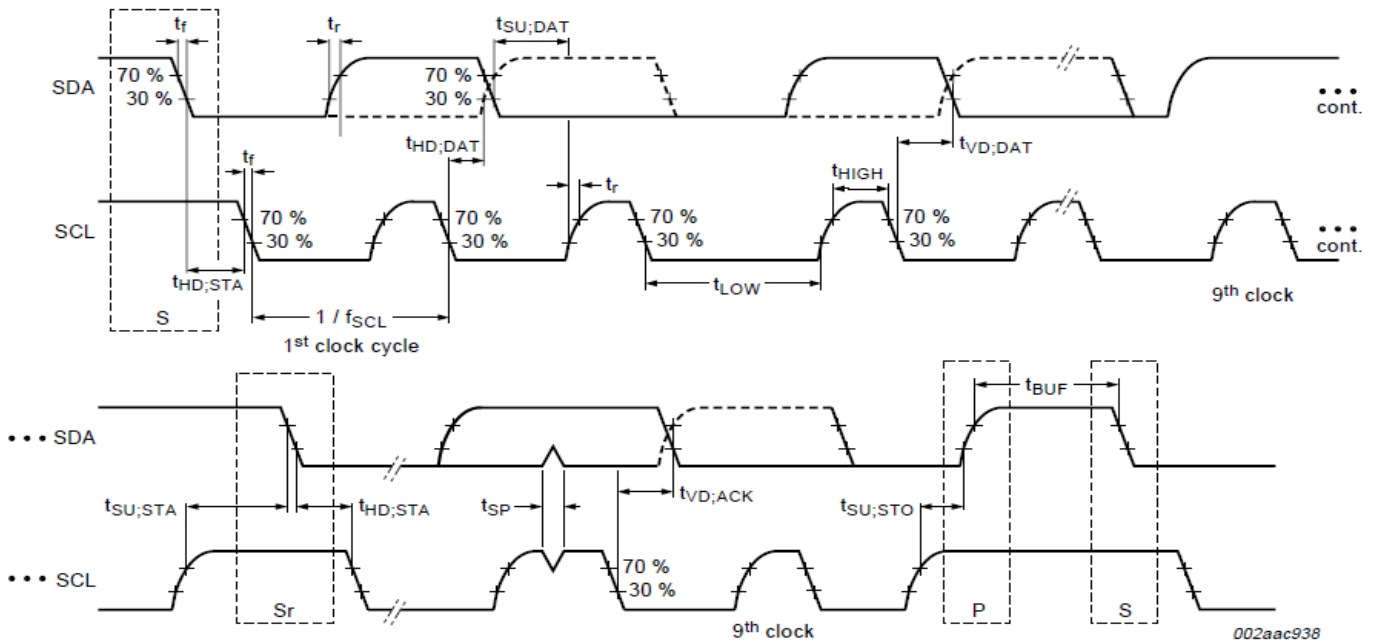

FIGURE 3. I²C TIMING DIAGRAM

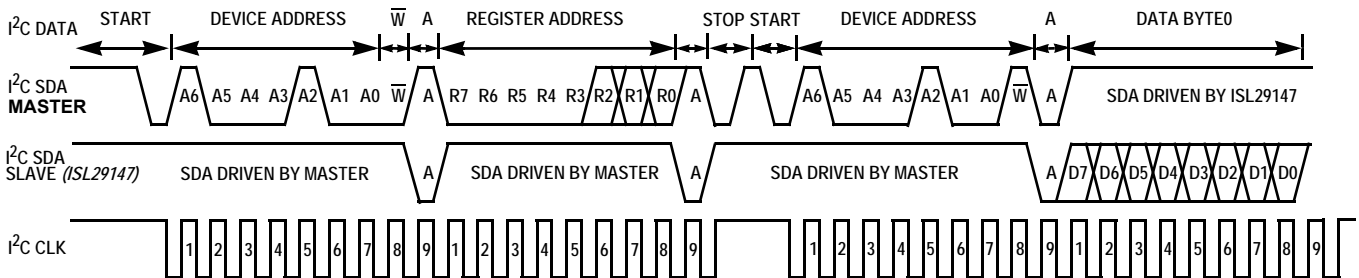

FIGURE 4. I²C DRIVER TIMING DIAGRAM FOR MASTER AND SLAVE CONNECTED TO COMMON BUS

Typical Performance Curves

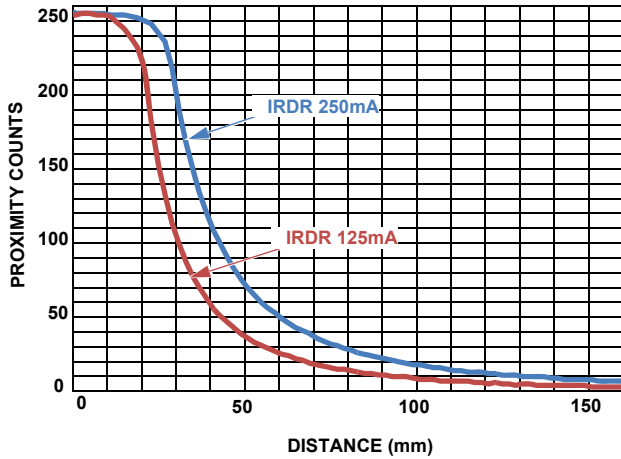

FIGURE 5. PROXIMITY SENSITIVITY (Note 11)

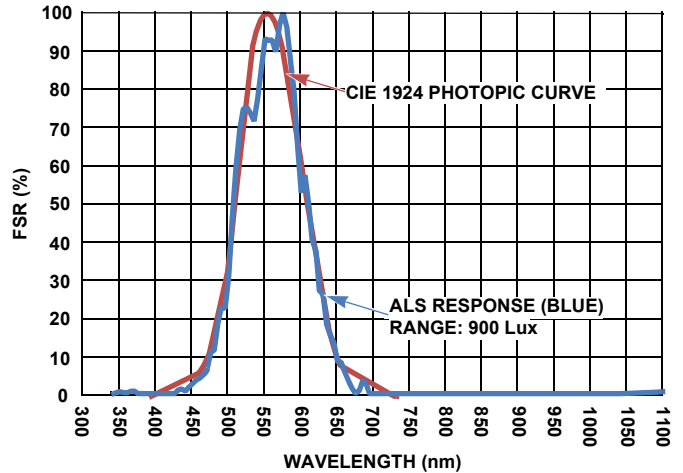

FIGURE 6. ALS SENSITIVITY (Note 12)

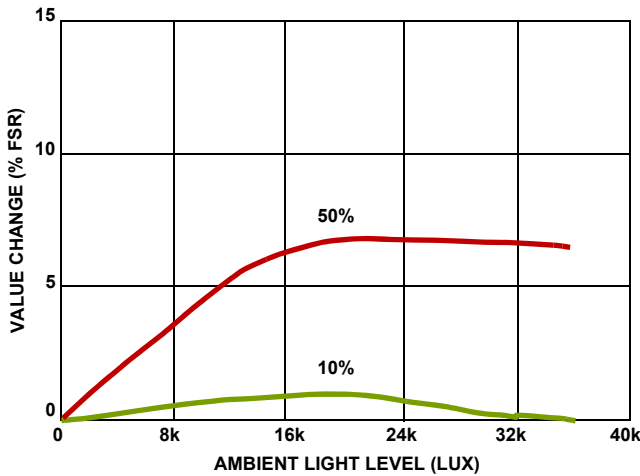

FIGURE 7. PROXIMITY AMBIENT LIGHT REJECTION (Note 13)

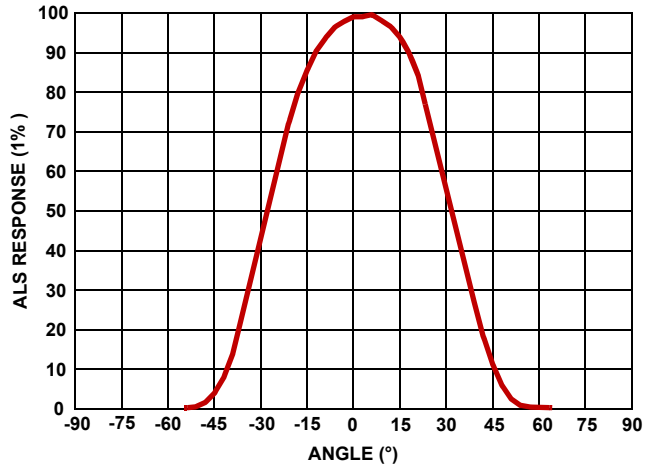

FIGURE 8. ALS ANGULAR SENSITIVITY (Note 14)

NOTES:

11. Figure 5 shows ISL29147 Proximity distance sweeps with different IRDR LED current settings using an 18% Grey card reflector.
12. Figure 6 shows ISL29147 Ambient Light Sensor Spectral response when compared to a theoretical CIE 1924 Photopic curve. The 'Blue' line shows the ISL29147 response and the 'Red' line depicts the CIE 1924 Photopic curve.
13. Figure 7 shows the ISL29147 Proximity Ambient Light Rejection using a Norwood Solar Emulator. At 40k Lux ambient light level, the Proximity Washout Count (Reg 0x0D[7:1]) is 127 indicating a saturation in Proximity Signal processing path. The Proximity Washout bit 0x0D[0] is active at approximately 90% of the maximum level. At 10% initial PROX count (due to optical leakage from IR LED to the ISL29147), the PROX data error is under 2%. At 50% initial PROX count (severe optical leakage), the PROX data error is about 7%.
14. Figure 8 shows the Ambient Light Sensor Angular Sensitivity of the ISL29147 using a white LED light source.

ISL29147 Register Set

TABLE 1. ISL29147 CONFIGURATION AND CONTROL REGISTERS

ADDRESS (HEX)	REGISTER NAME	POWER-ON DEFAULT	REGISTER ACCESS	BIT FIELDS	FUNCTION NAME/VALUE	FUNCTION
0x00	Device ID	b11000xxx	RO	[7:0]		Device Identification
				[7:3]	[11000]	ISL29147 Device ID
				[2:0]	[XXX]	Reserved
0x01	Config0	0x00	RW	[7:0]		Proximity Configuration
				[7:6]		Reserved
			RW	[5]	PROX_EN	Proximity Enable/Disable
					[1]	Enable
					[0]	Disable
			RW	[4:2]	PROX_SLP	Proximity Sleep Time Select
					[000]	400ms
					[001]	100ms
					[010]	50ms
					[011]	25ms
					[100]	12.5ms
					[101]	6.25ms
					[110]	3.125ms
			[111]	0ms		
			RW	[1:0]	IRDR_DRV	IR LED Current
[00]	31.25mA					
[01]	62.5mA					
[10]	125mA					
[11]	250mA					
0x02	Config1	0x00	RW	[7:0]		Proximity/ALS Configuration
				RW	[7]	INT_ALG
			[0]			Hysteresis Window
			[1]	Window Comparator		
			RW	[6:3]	PROX_OFFSET	Proximity Offset Compensation
			RW	[2]	ALS_EN	Ambient Light Sensing Enable/Disable
					[1]	Enable
			[0]	Disable		
			RW	[1:0]	ALS_RANGE	Ambient Light Sensor Range Select
					[00]	56.25 Lux
					[01]	112.5 Lux
					[10]	900 Lux
[11]	1800 Lux					
0x03	Config2	0x00	RW	[7:0]	ALS_IR_COMP	Ambient Light Sensor IR Compensation
			RW	[7:5]		Reserved
			RW	[4:0]	ALSIRComp	ALS Infra Red Compensation (Unsigned Binary)
0x04	INTConfig	0x10	RW	[7:0]	INTConfig	Interrupt Configuration, Status and Control

TABLE 1. ISL29147 CONFIGURATION AND CONTROL REGISTERS (Continued)

ADDRESS (HEX)	REGISTER NAME	POWER-ON DEFAULT	REGISTER ACCESS	BIT FIELDS	FUNCTION NAME/VALUE	FUNCTION	
			RO	[7]	PROX_INT_FLG	Proximity Interrupt Flag	
					[1]		Proximity Interrupt Event
					[0]		No Proximity Interrupt Event
			RW	[6:5]	PROX_PRST		Proximity Interrupt Reporting Persistency
					[00]		$\overline{\text{INT}}$ after 1 Proximity Flag Event
					[01]		$\overline{\text{INT}}$ after 2 Consecutive Proximity Flag Event
					[10]		$\overline{\text{INT}}$ after 4 Consecutive Proximity Flag Event
					[11]		$\overline{\text{INT}}$ after 8 Consecutive Proximity Flag Event
			RO	[4]	PWR_FAIL		Power Failure (Brown-out) Alarm
					[1]		Brown-Out Detected
					[0]		Normal Operation
			RO	[3]	ALS_INT_FLG		Ambient Light Sensor Interrupt Flag
					[1]		ALS Interrupt Flag Event
					[0]		No ALS Interrupt Flag Event
			RW	[2:1]	ALS_INT_PRST		ALS Interrupt Reporting Persistency
		[00]		$\overline{\text{INT}}$ after 1 ALS Flag Event			
		[01]		$\overline{\text{INT}}$ after 2 Consecutive ALS Flag Event			
		[10]		$\overline{\text{INT}}$ after 4 Consecutive ALS Flag Event			
		[11]		$\overline{\text{INT}}$ after 8 Consecutive ALS Flag Event			
RW	[0]	INT_CFG		Interrupt Output (Pin) Configuration			
		[1]		Interrupt if ALS and PROX Event			
		[0]		Interrupt if ALS or PROX Event			
0x05	PROX_INT_TL	0x00	RW	[7:0]	PROX_INT_TL	Proximity Interrupt LOW threshold	
0x06	PROX_INT_TH	0xFF	RW	[7:0]	PROX_INT_TH	Proximity Interrupt HIGH threshold	
0x07	ALS_INT_TL	0x00	RW	[7:0]	ALS_INT_TL1	ALS Interrupt LOW threshold bit[11:4]	
0x08	ALS_INT_TLH	0x0F	RW	[7:0]		ALS Interrupt LOW/HIGH threshold bits	
				[7:4]	ALS_INT_TL0	ALS Interrupt LOW threshold bit[3:0]	
				[3:0]	ALS_INT_TH1	ALS Interrupt HIGH threshold bit[11:8]	
0x09	ALS_INT_TH	0xFF	RW	[7:0]	ALS_INT_TH0	ALS Interrupt HIGH threshold bit[7:0]	
0x0A	PROX_DATA		RO	[7:0]	PROX_DATA	Proximity Data (Unsigned Binary)	
0x0B	ALS_DATA_HB		RO	[7:0]	ALS_DATA_HB	ALS Data HIGH Byte	
				[7:4]		Set to 0000	
				[3:0]		ALS Data Bit[11:8]	
0x0C	ALS_DATA_LB		RO	[7:0]	ALS_DATA_LB	ALS Data Bit[7:0]	
0x0D	PROX_AMBIR		RO	[7:0]	PROX_AMBIR	Proximity Mode Ambient IR Measurement	
				[7:1]		Proximity Mode Ambient IR Component	
			RO	[0]	PROX_WASH	Proximity Washout Status	
				[1]		Proximity Washout Detected	
				[0]		Normal Proximity Operation	
0x0E	Config3	0x00		[7:0]	SoftReset	Software Reset	
					0x38	Initiate Soft Reset	
					0x00	Normal operation	

Registers 0x01 and 0x02 are used to configure the primary proximity and ALS parameters. Register 0x03 is used for optimizing IR compensation in ALS measurements. A procedure to optimize IR compensation is described in [“ALS IR Compensation” on page 11](#).

Register 0x04 is the Interrupt Configuration and Status Register, they are used primarily to indicate interrupt events from proximity and ALS measurements. A PWR_FAIL bit to indicate a ‘Brown-Out’ event is available and is set in case of a power supply interruption. A ‘Brown-Out’ event does not generate a hardware interrupt. The host microcontroller must clear this bit by writing a ‘0’ to Reg 0x04[4].

Register 0x04 is also used to configure ALS and Proximity interrupt persistency and the operation of the $\overline{\text{INT}}$ pin.

Registers 0x05 and 0x06 are used to set the proximity ‘LOW’ and ‘HIGH’ threshold for proximity interrupt event generation.

Registers 0x07, 0x08 and 0x09 are used to set the ALS ‘LOW’ and ‘HIGH’ threshold. Two 12-bit numbers span three address locations as shown in [Table 1](#).

Data registers 0x0A holds result of proximity conversion. The proximity result should be validated by ‘Washout’ bit in Reg 0x0D[0]. Registers 0x0B and 0x0C holds result of an ALS measurement.

The ALS data is 12 bits wide. Least Significant Byte of the ALS data is available at address 0x0C and Most Significant Byte (MSB) of ALS data is available at address 0x0B. The MSB is right justified, i.e., the upper nibble is always zero and lower nibble contains four data bits.

Register 0x0D[7:1] contains ambient IR measurement in proximity measurement phase. This measurement is for detecting ambient Wash out condition, which is indicated by Reg 0x0D[0] being ‘HIGH’. Proximity ‘Washout’ is described in [“Proximity Ambient Washout Detection” on page 11](#).

A software reset can be initiated by writing 0x38 to Register 0x0E.

ISL29147 Operation

Photodiodes and ADCs

The ISL29147 contains two photodiode arrays, which convert photons (light) into current. The ALS photodiodes are designed to mimic the human eye’s wavelength response curve to visible light. The ALS photodiodes’ current output is digitized by a 12-bit ADC.

The ALS ADC output is accessed by reading from Reg 0x0B and 0x0C when the ADC conversion is completed.

The ALS ADC converter uses a charge-balancing architecture. Charge-balancing is best suited for converting small current signals in the presence of periodic AC noise. The ISL29147 targets an integration time of 90ms, which can vary $\pm 15\%$ from nominal. The ALS integration time is intended to minimize 60Hz flicker.

The proximity sensor uses an 8-bit ADC, which operates in a similar fashion. The IRDR pin drives (pulses) an infrared LED, the emitted IR reflects off an object back into the ISL29147, and the photo diodes convert the reflected IR to a current signal in 0.5ms. The ADC subtracts the IR reading before and after the LED is driven to remove ambient IR contribution.

The ALS runs continuously with new data available every 90ms. The proximity sensor runs continuously with a time between conversions controlled by PROX_SLP (Reg 0x01[6:4]).

Ambient Light Sensing

The ISL29147 is set for ambient light sensing when Register bit ALS_EN = 1. Four measurement ranges from 56.25 Lux to 1800 Lux are available. The ALS measurement range is configured via Reg 0x02[1:0].

Proximity Sensing

When proximity sensing is enabled (PROX_EN = 1), the external IR LED is driven for 90 μ s by the built-in IR LED driver through the IRDR pin.

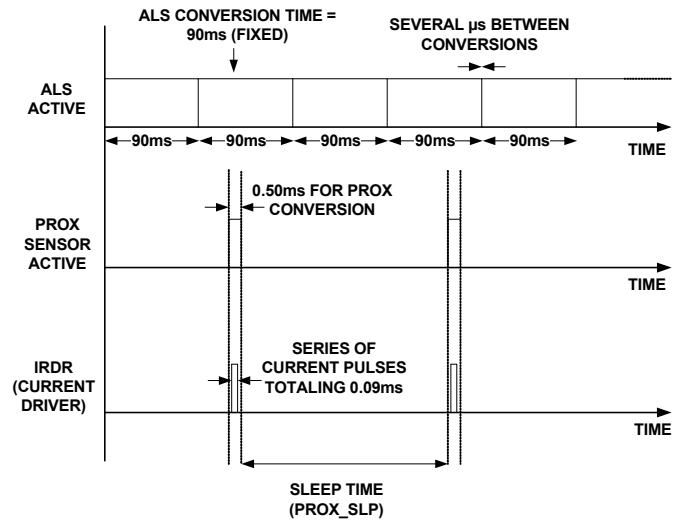

FIGURE 9. TIMING DIAGRAM FOR PROX/ALS EVENTS - NOT TO SCALE

The IR LED current depends on PROX_DRV (Reg 0x01[1:0]). Drive current settings are as shown in [Table 1](#). The IR LED drive is in high impedance state when not active.

When the IR from the LED reaches an object and gets reflected back to the ISL29147, the reflected IR light is converted into a current. This current is converted to digital data using an 8-bit ADC. The proximity measurement takes 0.5ms for one conversion including the 90 μ s LED drive time. The period between proximity measurements is determined by PROX_SLP (sleep time) in Reg 0x01[4:2].

Average LED driving current consumption is given by [Equation 1](#).

$$I_{\text{IRDR:AVE}} = \frac{I_{\text{IRDR:PEAK}} \times 90\mu\text{s}}{T_{\text{SLEEP}}} \quad (\text{EQ. 1})$$

A typical IRDR scheme is 250mA pulses every 400ms, averaging about 56 μ A DC.

Total Current Consumption

Total current consumption is the sum of I_{DD} and I_{RDR} . The IRDR pin sinks current and the average IRDR current is calculated by using [Equation 1](#). The I_{DD} depends on voltage and the mode of operation. For simplicity, [Equation 1](#) ignores proximity ADC conversion time since it is much smaller than the sleep time.

ALS IR Compensation

The ISL29147 is designed for operation under dark glass cover. Glass or plastic covers can significantly attenuate visible light and pass the Infrared light without much attenuation. Consequently, the ISL29147 under a glass cover experiences an IR rich environment.

The on-chip ALS passive optical filter on the ISL29147 is designed to block most of the IR incident on the ALS photo diodes. In addition, the ISL29147 provides a programmable active IR compensation that subtracts residual IR still reaching the sensor.

The ALS_IR_COMP register (Reg 0x03[4:0]) allows fine tuning of the residual infrared component from the ALS output.

The recommended procedure for determining ALS IR compensation is as follows:

- Illuminate the ISL29147 based product with a light source without IR, such as a white LED. Record the ALS measurement and the Lux level.
- Illuminate the device with an IR LED and the White LED. Take an ALS measurement and Lux level measurement.
- Adjust the ALS_IR_COMP register (Reg 0x03, bits 4:0) to compensate for the IR contribution.
- Repeat steps above until the IR light source contribution to the ALS measurement is under 10 percent assuming no change in Lux level due to IR light source.

Proximity Offset

Systems built with a protective glass cover over the ISL29147 can provide light 'leakage' or 'crosstalk' from the IR LED by reflection from the glass saturating the proximity sensor measurement system ([Figure 10](#)).

Saturation can occur when the reflection from the glass with no object in the proximity detection space exceeds the full scale of the measurement system. The ISL29147 proximity system provides a user programmable proximity offset correction to compensate for this reflection.

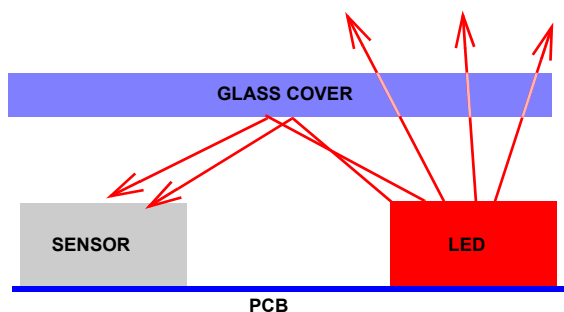

FIGURE 10. PROXIMITY SET-UP HIGHLIGHTING CROSSTALK REFLECTED FROM COVER GLASS

The PROX_IR_COMP register (Reg 0x02[6:3]) applies a corrective offset to the received signal prior to ADC conversion, which allows the signal to be brought within the usable range of the proximity measurement system.

Proximity Ambient Washout Detection

Optical proximity sensor can saturate when illuminated with excessive ambient light. The ISL29147 provides a warning flag when the proximity measurement may be erroneous due to excessive ambient light. The PROX_WASH register (Reg 0x0D[0]) reports this condition.

Interrupts Events

The ISL29147 interrupts are designed to minimize host micro-controller overhead of continuous polling. The ISL29147 can generate interrupts on the results of an ALS measurement or proximity measurement.

The ALS interrupt event ALS_FLAG (Reg 0x04[3]) is governed by Reg 0x07 through Reg 0x09. Two 12-bit high and low threshold values are written to these registers. The ISL29147 will set the ALS interrupt flag, if the ADC conversion count in Registers 0x0B and 0x0C are outside the programmed thresholds. The ALS_FLAG is cleared by writing a '0' to Reg 0x04[3].

A proximity interrupt event (PROX_FLAG) is governed by the high and low thresholds in Reg 0x05 and Reg 0x06 (PROX_LT and PROX_HT) are indicated by Reg 0x04[7]. PROX_FLAG is set when the measured proximity data is more than the higher threshold. The proximity interrupt flag is cleared when the proximity data is lower than the low proximity threshold or by writing a '0' to Reg 0x04[7].

The Proximity interrupt generation can be selected between 'out-of-window' threshold and hysteresis schemes. When the PROX_INT_ALG register (Reg 0x02, Bit 7) is set to 0, proximity uses a hysteresis scheme; when set to 1, proximity uses a window comparator scheme.

In hysteresis mode, the interrupt event is generated if the proximity ADC count is higher than the PROX_HT threshold and the interrupt event is cleared when the proximity ADC count is less than the PROX_LT threshold. The interrupt event flag can also be cleared by writing a '0' to Reg 0x04[7].

INTERRUPT PERSISTENCE

To minimize interrupt events due to 'transient' conditions, an interrupt persistency option is available for both ALS and proximity measurements. Persistency requires 'X-consecutive' interrupt flags before the INT pin is driven low. Both ALS and PROX have their own independent interrupt persistency options. ALS_PRST and PROX_PRST configuration are controlled from Reg 0x04.

Power-Up and 'Brown-Out' Reset

The ISL29147 has an enhanced power-on-reset system. A 'Brown-Out' detector flag in Reg 0x04[4] informs the system that the device has powered-up properly. This flag should be reset as part of the initialization sequence.

A 'Brown-Out' condition is defined as an operating condition when the power supply voltage is not within the specified limits. To prevent this condition we recommend the power supply slew rate to be greater than 0.5 V/ms.

During the brown-out period at power-up, the I²C interface and the IR LED driver are inactive. Following brown-out, the I²C interface is reinitialized and the configuration registers are set to power-up default values. After power-up and during device initialization, host should examine that the PWR_FAIL flag (Reg 0x04[4]) is set and then clear the flag by writing '0' to Reg 0x04[4].

Following power-up, a 'Brown-Out' condition, if detected, is reported by PWR_FAIL flag by Reg 0x04[4]. Device configuration registers are not set to their power-up default after 'Brown-Out'. PWR_FAIL flag should be periodically monitored to detect post power-up power supply interruption.

Power-Down

Setting ALS_EN (Reg 0x02[2]) and PROX_EN (Reg 0x01[5]) to '0' puts the ISL29147 into a power-down state with power supply current dropping to less than 1 μ A. All configuration registers are maintained in power-down mode.

Soft Reset

A software reset to ISL29147 can be initiated by writing 0x38 to Reg 0x0E. Following reset, all configuration registers are set to their default power-up state. After soft reset, the ISL29147 defaults to the power-down configuration.

ALS Data Count Read Out

A two byte I²C read from ALS_DATA_HB outputs MSB 1st data on SDA. This data is LSB justified with a zero fill for unused bits.

NOTE: The MSB byte address precedes the LSB byte address. The ALS count is 256*(ALS_DATA_HB) + ALS_DATA_LB.

Proximity Detection of Various Objects

The Proximity sensing relies on the amount of IR reflected back from objects. A perfect black object would absorb all incident light and reflect no photons. The ISL29147 is sensitive enough to detect black ESD foam, which reflects only 1% of IR. Blonde hair typically reflects more than brown hair and skin tissue is more reflective than human hair.

IR penetrates into the skin and is reflected from within. As a result, the proximity count generally peaks at contact and monotonically decreases as skin moves away. The reflective characteristics of skin are very different from that of an inanimate object such as paper.

Typical Application Circuit

A typical application circuit for the ISL29147 is shown in Figure 11. The ISL29147's I²C address is internally hard wired as '1000100x', with x representing the R/W bit. The device can be connected to a system's I²C bus together with other I²C compliant devices. It is important to ensure that there is no address conflict with other I²C devices on the bus.

The SCL, SDA and $\overline{\text{INT}}$ pins on the ISL29147 are open drain and require pull-up resistors for proper system operation. Values of the pull-up resistors is system dependent and can range from 2.2k to 10k depending upon the number of I²C devices on the bus.

The proximity sensing system can be powered using a dual power supply or using a single power supply. In dual supply configuration, the IR LED and the ISL29147 are powered from separate power supplies. The V_{DD} IRLED can range from 2.25V to 5.0V and the V_{DD} can range from 2.25V to 3.63V. In dual supply configuration, resistor R₁ should not be installed.

In single supply configuration, the IR LED and the ISL29147 are powered from the same power source. The V_{DD} IRLED can range from 2.25V to 3.63V and the V_{DD} is derived from V_{DD} IRLED using resistor R₁.

In either power supply configuration, a 1 μ F decoupling capacitor should be installed close to the VDD pin, and another 1 μ F decoupling capacitor should be placed close to the IR LED anode.

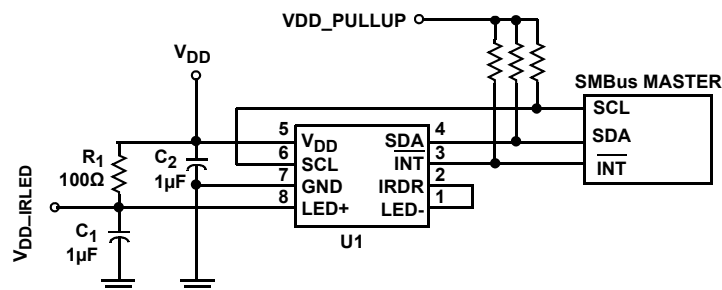

R₁: 100 Ω 5% RESISTOR
C₁, C₂: 1 μ F CERAMIC 10V CAPACITOR
FIGURE 11. TYPICAL APPLICATIONS CIRCUIT

Soldering Considerations

Convection heating is recommended for reflow soldering; direct-infrared heating is not recommended. The plastic optical co-package does not require a custom reflow soldering profile. A standard reflow soldering profile with a +260 °C maximum is recommended. Additional information regarding soldering the ISL29147 is included in Intersil Technical Brief [TB493](#).

PCB Layout Considerations

The ISL29147 is relatively insensitive to PCB layout. Adherence to the following guidelines will ensure first pass success and best performance.

Route the I²C/SMBus SCL, SDA and the $\overline{\text{INT}}$ traces away from sources of switching noise.

The ISL29147 pin GND should connect to a low impedance ground with low resistance and low inductance traces. Ferrite beads and inductors should be avoided in the ground path. If necessary, due to RF consideration, the effects of DCR (DC resistance) should be evaluated on ALS and Proximity system performance.

A 1 μ F ceramic decoupling capacitor should be placed as close to VDD pin as possible.

The ISL29147 drives the IR LED with 0.09ms current pulses. To supply this pulsed current, a 1 to 10 μ F bulk decoupling capacitor (C₁) must be connected from the IR LED anode to the GND pin to minimize instantaneous resistive voltage drop. The connection from IR LED cathode to the IRDR pin should be short and with minimal inductance. Similarly, connection from IR LED anode to VDD_IRLED must be made with a low impedance trace.

For most applications, a single power supply may be used to power the IR LED and the ISL29147. Use of resistor R₁ and capacitor C₂ ([Figure 11](#)) to help filter out the power supply noise generated from IR LED switching, is recommended for best ISL29147 performance when using a single power supply. For dual supply operation, resistor R₁ should not be installed.

Revision History

The revision history provided is for informational purposes only and is believed to be accurate, but not warranted. Please go to web to make sure you have the latest revision.

DATE	REVISION	CHANGE
January 06, 2015	FN8409.3	Ordering information table on page 2: Corrected typo from ISL29147IROMZ-T7 to ISL29147IROMZ-T7 (changed from zero to letter "O")
January 14, 2014	FN8409.2	Updated POD L8.2.40x4 - from rev 4 to rev 5 - changes from rev 4: top view re-drawn - changed from round to oval detector and added dimensions.
December 9, 2013	FN8409.1	Updated POD L8.2.40x4 - Bottom View changed Pin 1 Index Mark from Pin 1 index mark to Pin 4 index area. Updated Note 4 to show correct Pin number.
September 16, 2013	FN8409.0	Initial Release.

About Intersil

Intersil Corporation is a leading provider of innovative power management and precision analog solutions. The company's products address some of the largest markets within the industrial and infrastructure, mobile computing and high-end consumer markets.

For the most updated datasheet, application notes, related documentation and related parts, please see the respective product information page found at www.intersil.com.

You may report errors or suggestions for improving this datasheet by visiting www.intersil.com/ask.

Reliability reports are also available from our website at www.intersil.com/support

© Copyright Intersil Americas LLC 2013-2015. All Rights Reserved.
All trademarks and registered trademarks are the property of their respective owners.

For additional products, see www.intersil.com/en/products.html

Intersil products are manufactured, assembled and tested utilizing ISO9001 quality systems as noted in the quality certifications found at www.intersil.com/en/support/qualandreliability.html

Intersil products are sold by description only. Intersil may modify the circuit design and/or specifications of products at any time without notice, provided that such modification does not, in Intersil's sole judgment, affect the form, fit or function of the product. Accordingly, the reader is cautioned to verify that datasheets are current before placing orders. Information furnished by Intersil is believed to be accurate and reliable. However, no responsibility is assumed by Intersil or its subsidiaries for its use; nor for any infringements of patents or other rights of third parties which may result from its use. No license is granted by implication or otherwise under any patent or patent rights of Intersil or its subsidiaries.

For information regarding Intersil Corporation and its products, see www.intersil.com

Package Outline Drawing

L8.2.40x4

8 LEAD OPTICAL CO-PACKAGE

Rev 5, 12/13

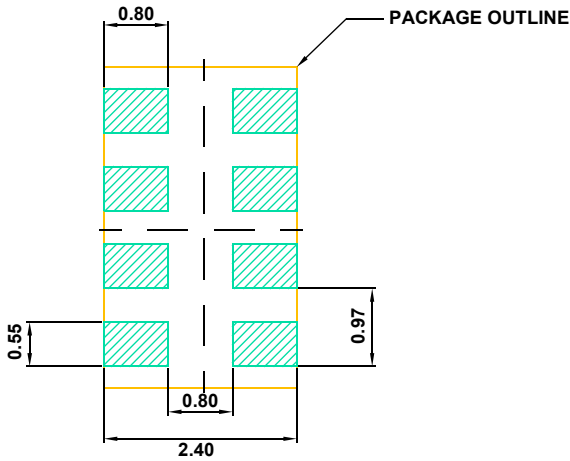
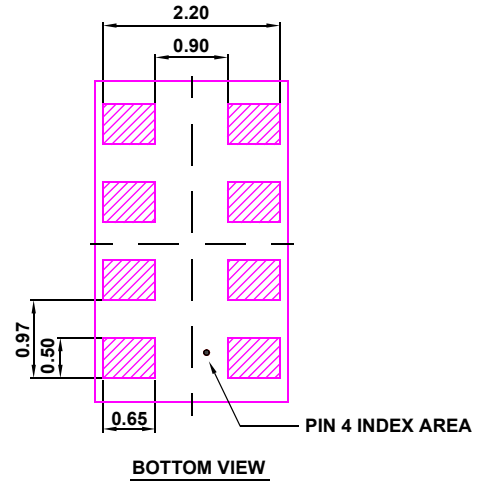
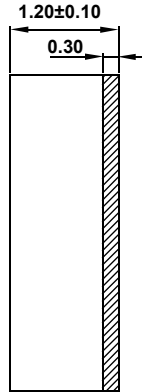
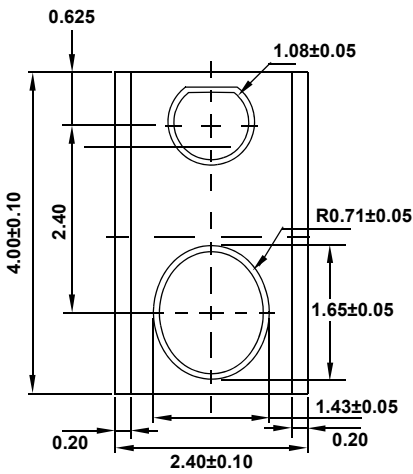

TYPICAL RECOMMENDED LAND PATTERN

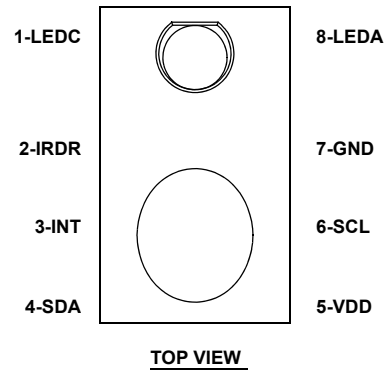

NOTES:

1. Dimensions are in millimeters.
Dimensions in () for Reference Only.
2. Dimensioning and tolerancing conform to ASME Y14.5m-1994.
3. Unless otherwise specified, tolerance: Decimal ± 0.05
4. Pin #4 identifier is a laser-etched dot on bottom surface.