

$V_{CC} = 12V$, $R_L = 1M$, unless otherwise specified. (Cont.)

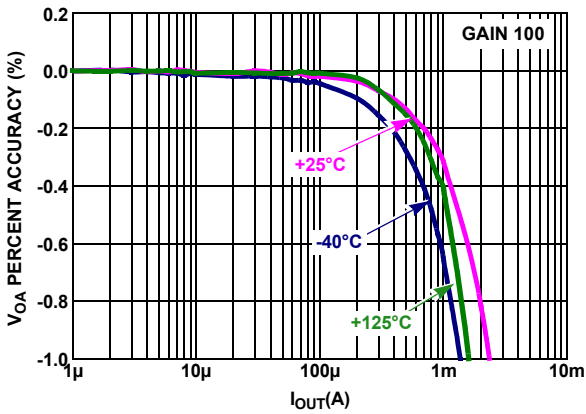

Figure 7. Normalized V_{OA} vs I_{OUT}

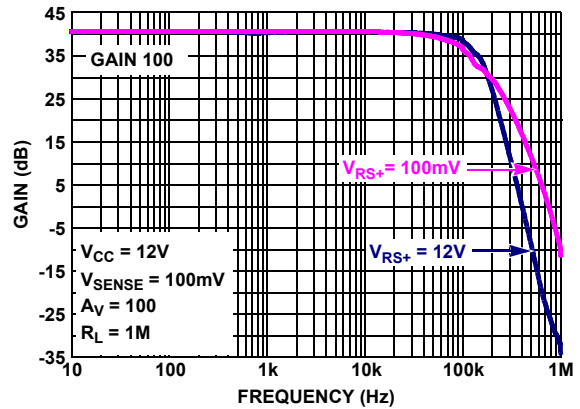

Figure 8. GAIN vs FREQUENCY $V_{RS+} = 100mV/12V$, $V_{SENSE} = 100mV$, $V_{OUT} = 250mV_{P-P}$

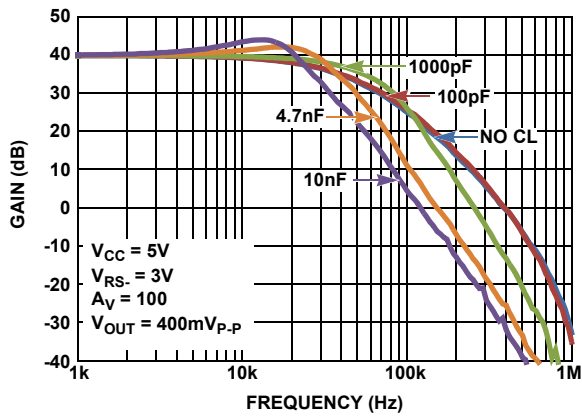

Figure 9. Capacitive Load Drive Gain vs Frequency

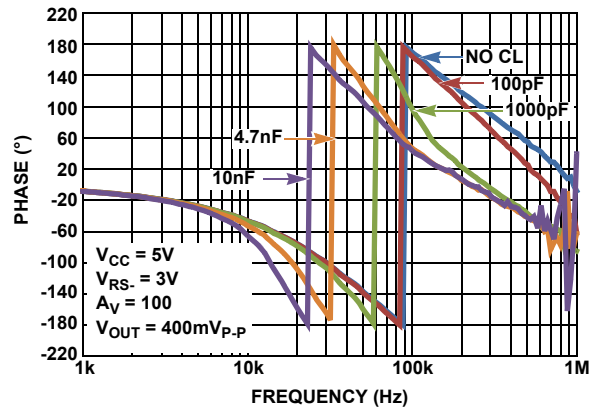

Figure 10. Capacitive Load Drive Phase vs Frequency

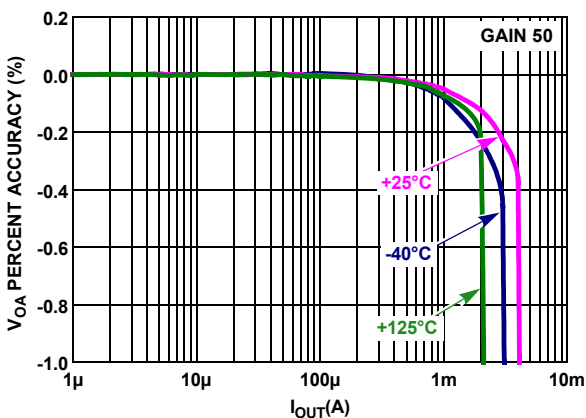

Figure 11. Normalized V_{OA} vs I_{OUT}

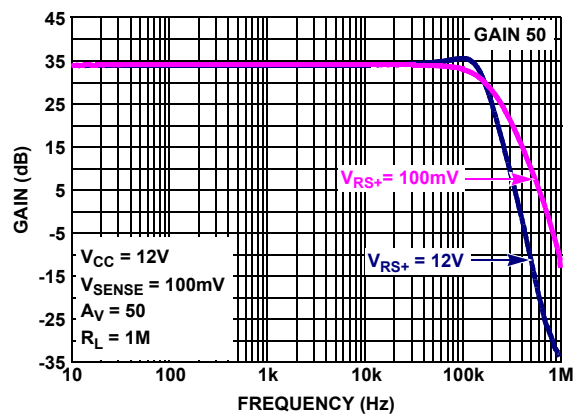

Figure 12. Gain vs Frequency $V_{RS+} = 100mV/12V$, $V_{SENSE} = 100mV$, $V_{OUT} = 250mV_{P-P}$

$V_{CC} = 12V$, $R_L = 1M$, unless otherwise specified. (Cont.)

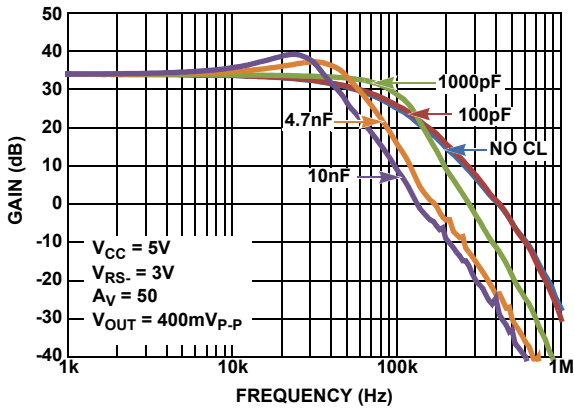

Figure 13. Capacitive Load Drive Gain vs Frequency

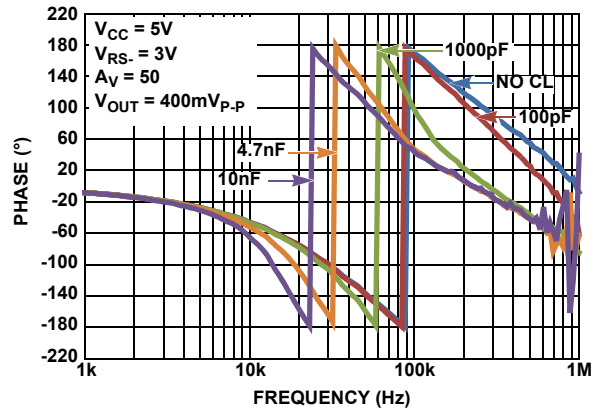

Figure 14. Capacitive Load Drive Phase vs Frequency

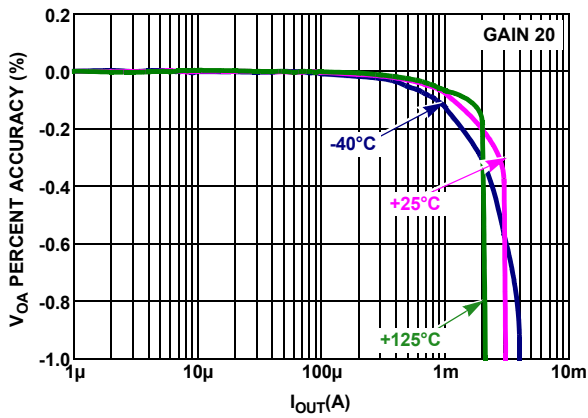

Figure 15. Normalized V_{OA} vs I_{OUT}

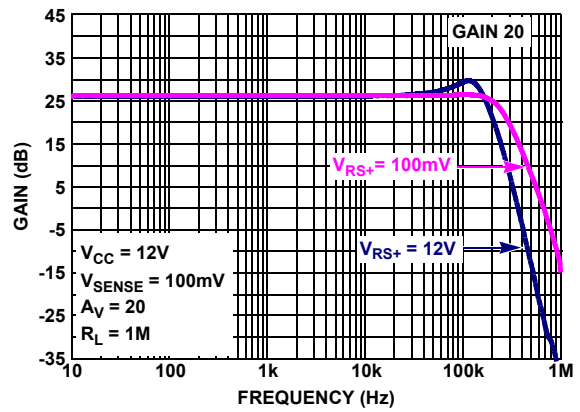

Figure 16. Gain vs Frequency $V_{RS+} = 100mV/12V$, $V_{SENSE} = 100mV$, $V_{OUT} = 250mV_{p-p}$

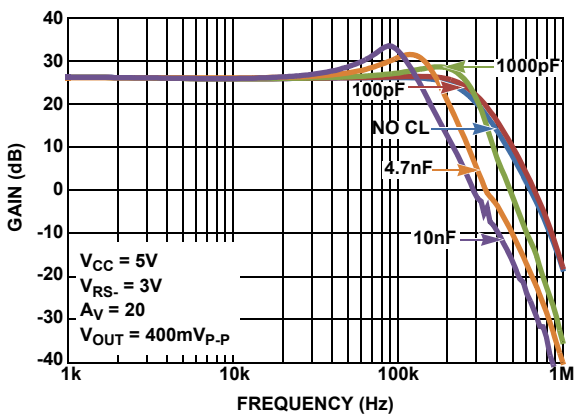

Figure 17. Capacitive Load Drive Gain vs Frequency

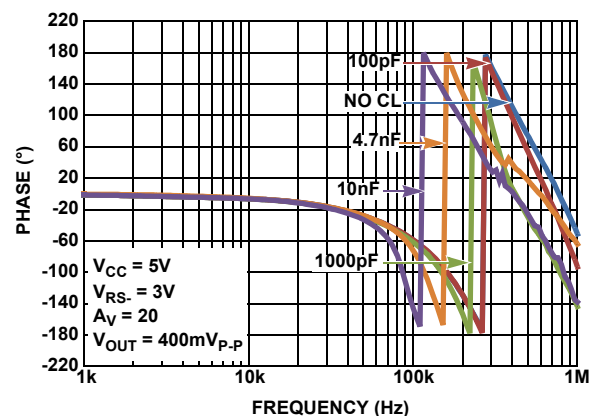

Figure 18. Capacitive Load Drive Phase vs Frequency

$V_{CC} = 12V$, $R_L = 1M$, unless otherwise specified. (Cont.)

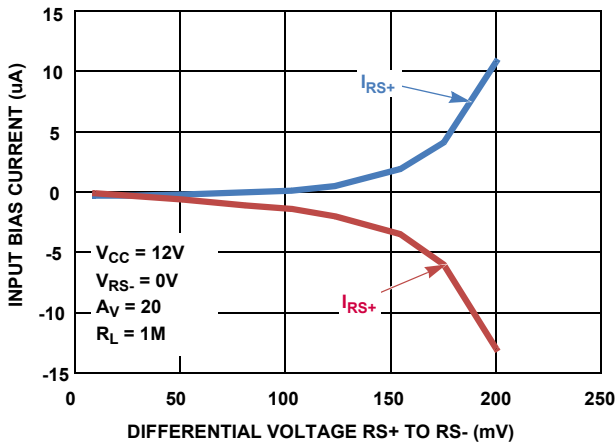

Figure 19. Low-Side Current Sensing Input Bias Currents

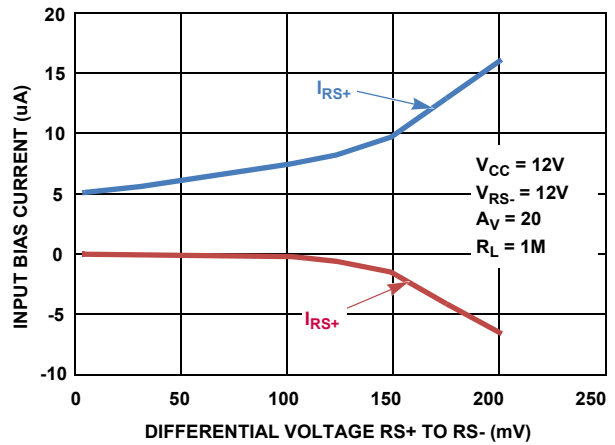

Figure 20. High-Side Current Sensing Input Bias Currents

4.1 Test Circuits and Waveforms

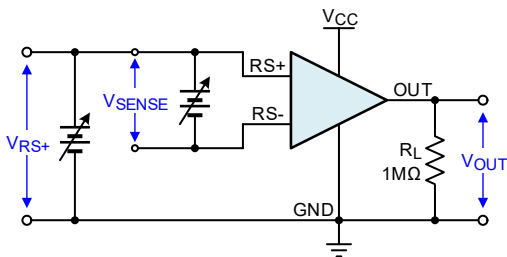

Figure 21. I_{CC} , V_{OS} , V_{OA} , $CMRR$, $PSRR$, Gain Accuracy

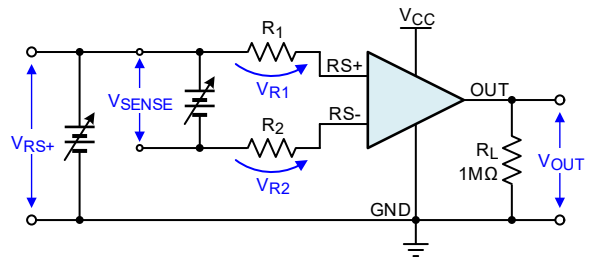

Figure 22. Input Bias Current, Leakage Current

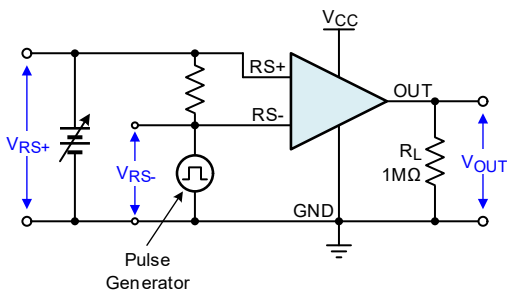

Figure 23. Slew Rate, t_s , Saturation Recovery Time

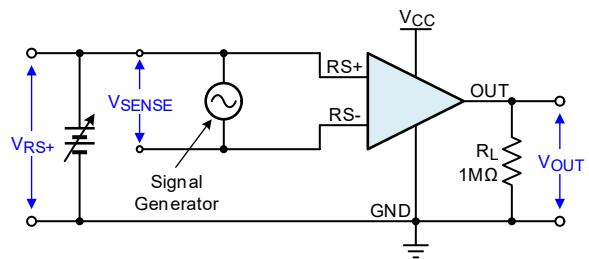

Figure 24. Gain vs Frequency

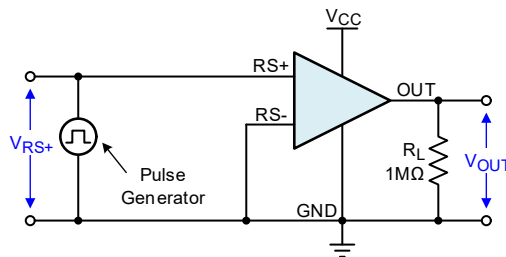

Figure 25. Slew Rate

5. Applications Information

5.1 Functional Description

The ISL28005-20, ISL28005-50 and ISL28005-100 are single supply, uni-directional current sense amplifiers with fixed gains of 20V/V, 50V/V and 100V/V respectively.

The ISL28005 is a 2-stage amplifier. Figure 26 shows the active circuitry for high-side current sense applications where the sense voltage is between 1.35V to 28V. Figure 27 shows the active circuitry for ground sense applications where the sense voltage is between 0V to 1.35V.

The first stage is a bi-level trans-conductance amp and level translator. The gm stage converts the low voltage drop (V_{SENSE}) sensed across an external milli-ohm sense resistor, to a current (at $g_m = 21.3\mu A/V$). The trans-conductance amplifier forces a current through R_1 resulting to a voltage drop across R_1 that is equal to the sense voltage (V_{SENSE}). The current through R_1 is mirrored across R_5 creating a ground-referenced voltage at the input of the second amplifier equal to V_{SENSE} .

The second stage is responsible for the overall gain and frequency response performance of the device. The fixed gains (20, 50, 100) are set with internal resistors R_f and R_g . The only external component needed is a current sense resistor (typically 0.001 Ω to 0.01 Ω , 1W to 2W).

The transfer function is given in Equation 1 where $I_S R_S$ is the product of the load current and the sense resistor and is equal to V_{SENSE} .

$$(EQ. 1) \quad V_{OUT} = GAIN \times (I_S R_S + V_{OS})$$

When the sensed input voltage is >1.35V, the $g_{m_{HI}}$ amplifier path is selected and the input gm stage derives its $\sim 2.86\mu A$ supply current from the input source through the $RS+$ terminal. When the sense voltage at $RS+$ drops below the 1.35V threshold, the $g_{m_{LO}}$ amplifier is enabled for Low Side current sensing. The $g_{m_{LO}}$ input bias current reverses, flowing out of the $RS-$ pin. Since the $g_{m_{LO}}$ amplifier is sensing voltage around ground, it cannot source current to R_5 . A current mirror referenced off V_{CC} supplies the current to the second stage for generating a ground referenced output voltage. See Figure 19 and Figure 20 for typical input bias currents for high-side and low-side current sensing.

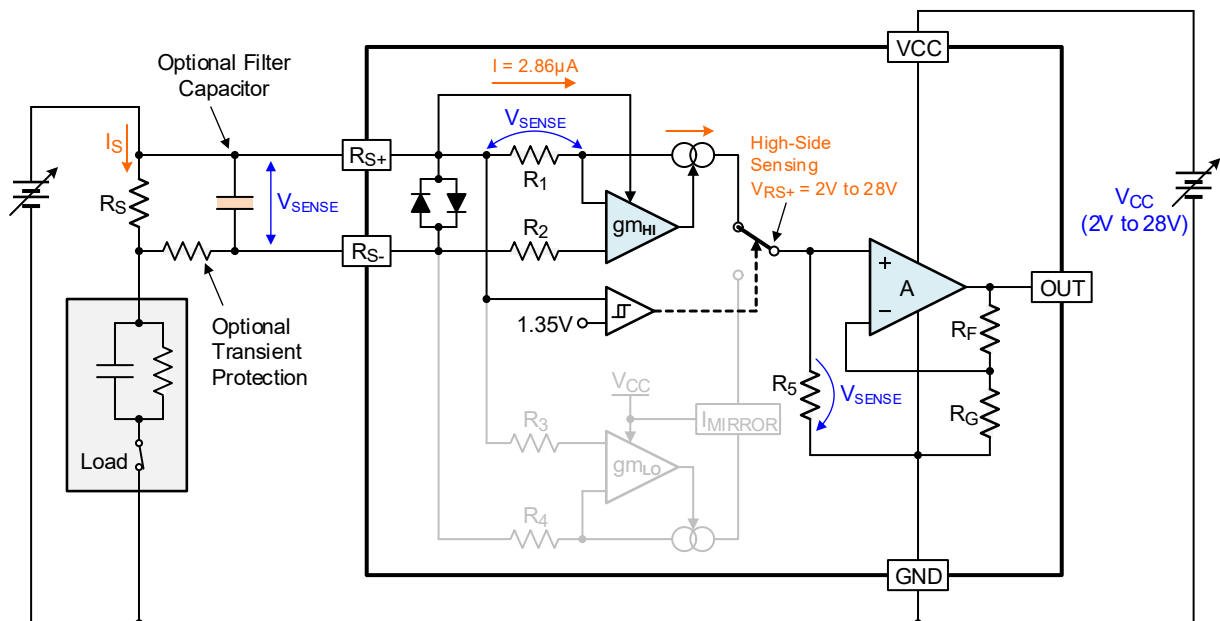

Figure 26. High-Side Current Detection

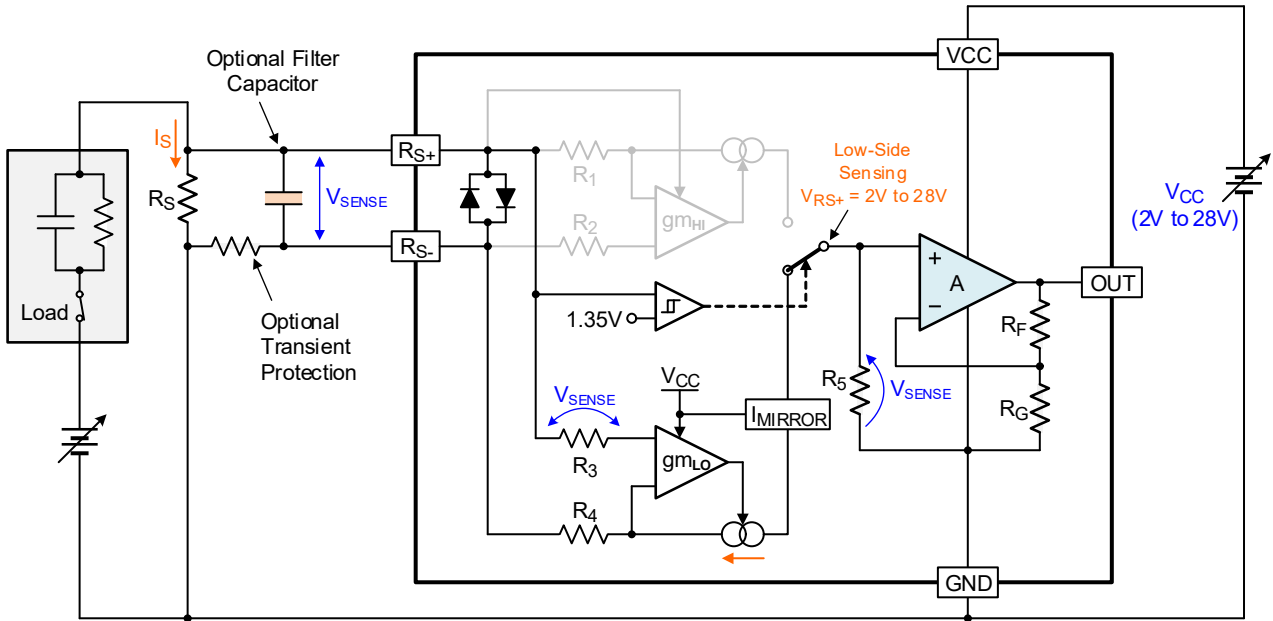

Figure 27. Low-Side Current Detection

5.2 Hysteretic Comparator

The input trans-conductance amps are under control of a hysteretic comparator operating from the incoming source voltage on the RS+ pin (see Figure 28). The comparator monitors the voltage on RS+ and switches the sense amplifier from the low-side gm amp to the high-side gm amplifier whenever the input voltage at RS+ increases above the 1.35V threshold. Conversely, a decreasing voltage on the RS+ pin, causes the hysteretic comparator to switch from the high-side gm amp to the low-side gm amp as the voltage decreases below 1.35V. It is that low-side sense gm amplifier that gives the ISL28005 the proprietary ability to sense current all the way to 0V. Negative voltages on the RS+ or RS- are beyond the sensing voltage range of this amplifier.

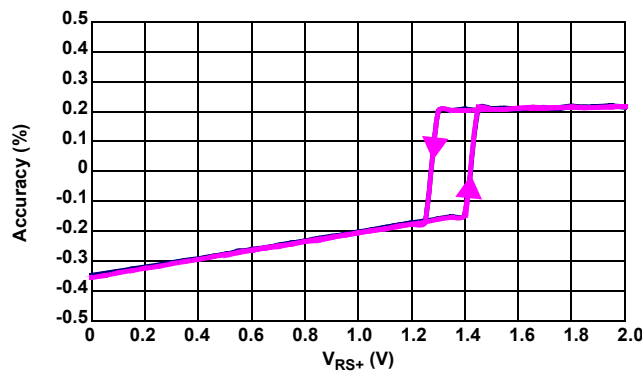

Figure 28. Gain Accuracy vs V_{RS+} = 0V to 2V

5.3 Typical Application Circuit

Figure 29 shows the basic application circuit and optional protection components for switched-load applications. For applications where the load and the power source is permanently connected, only an external sense resistor is needed. For applications where fast transients are caused by hot plugging the source or load, external protection components may be needed. The external current limiting resistor (R_P) in Figure 29 may be required to limit the peak current through the internal ESD diodes to $< 20\text{mA}$. This condition can occur in applications that experience high levels of in-rush current causing high peak voltages that can damage the internal ESD diodes. An R_P resistor value of 100Ω provides protection for a 2V transient with the maximum of 20mA flowing through the input while adding only an additional $13\mu\text{V}$ (worse case over-temperature) of V_{OS} . See the following formula:

$$((R_P \times I_{R_S}) = (100\Omega \times 130\text{nA}) = 13\mu\text{V})$$

Switching applications can generate voltage spikes that can overdrive the amplifier input and drive the output of the amplifier into the rails, resulting in a long overload recovery time. Capacitors C_M and C_D filter the common mode and differential voltage spikes.

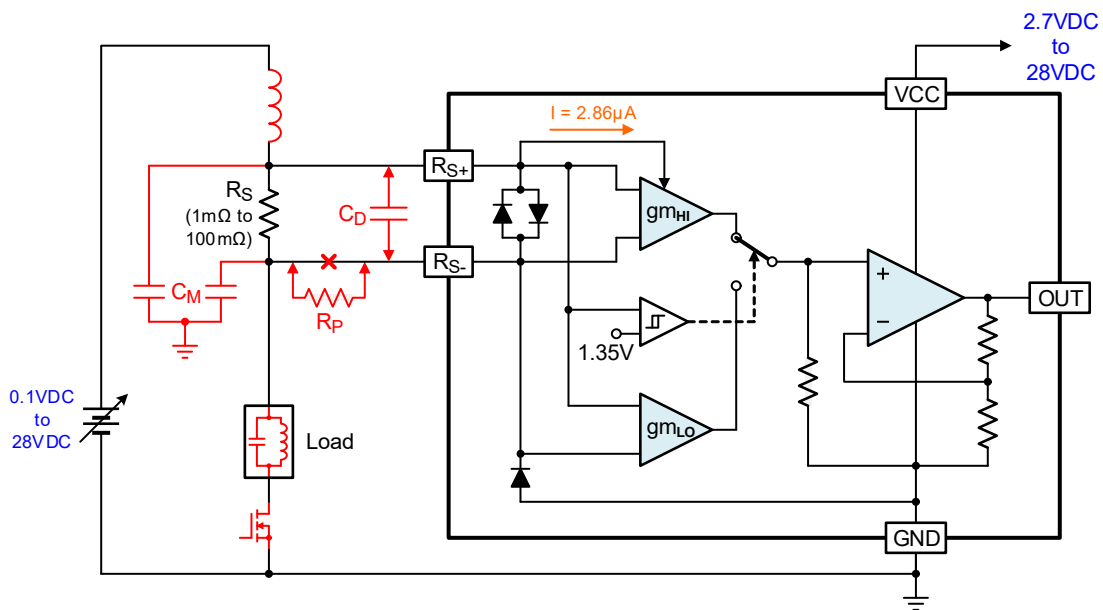

Figure 29. Typical Application Circuit

5.4 Error Sources

There are 3 dominant error sources: gain error, input offset voltage error, and Kelvin voltage error (see Figure 30). The gain error is dominated by the internal resistance matching tolerances. The remaining errors appear as sense voltage errors at the input to the amplifier. They are V_{OS} of the amplifier and Kelvin voltage errors. If the transient protection resistor is added, an additional V_{OS} error can result from the $I \times R$ voltage due to input bias current. The limiting resistor should only be added to the R_{S-} input, due to the high-side gm amplifier (g_{mHI}) sinking several micro amps of current through the R_{S+} pin.

6. Layout Guidelines

6.1 Kelvin Connected Sense Resistor

The source of Kelvin voltage errors is illustrated in [Figure 30](#). The resistance of 1/2 oz. copper is $\sim 1\text{m}\Omega$ per square with a TC of $\sim 3900\text{ppm}/^\circ\text{C}$ ($0.39\%/^\circ\text{C}$). When you compare this unwanted parasitic resistance with the total of $1\text{m}\Omega$ to $10\text{m}\Omega$ resistance of the sense resistor, it is easy to see why the sense connection must be chosen very carefully. For example, consider a maximum current of 20A through a 0.005Ω sense resistor, generating a $V_{\text{SENSE}} = 0.1$ and a full scale output voltage of 10V ($G = 100$). Two side contacts of only 0.25 square per contact puts the V_{SENSE} input about $0.5 \times 1\text{m}\Omega$ away from the resistor end capacitor. If only 10A the 20A total current flows through the kelvin path to the resistor, you get an error voltage of 10mV ($10\text{A} \times 0.5\text{sq} \times 0.001\Omega/\text{sq} = 10\text{mV}$) added to the 100mV sense voltage for a sense voltage error of 10% $(0.110\text{V} - 0.1)/0.1\text{V} \times 100$.

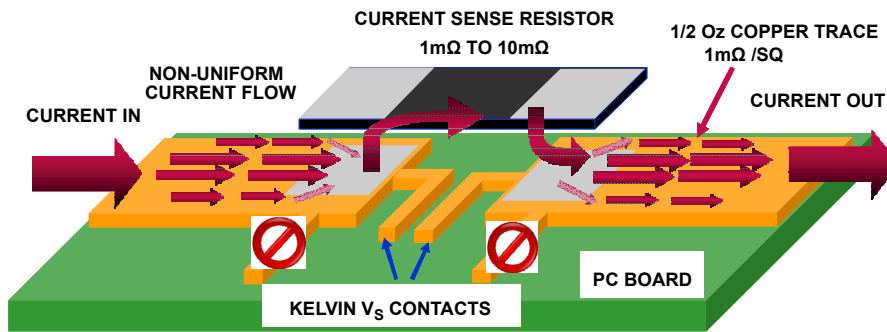

Figure 30. PC Board Current Sense Kelvin Connection

6.2 Overall Accuracy (V_{OA} %)

V_{OA} is defined as the total output accuracy Referred-to-Output (RTO). The output accuracy contains all offset and gain errors, at a single output voltage. [Equation 2](#) is used to calculate the % total output accuracy where $V_{\text{OUT Actual}} = V_{\text{SENSE}} \times \text{GAIN}$.

$$\text{(EQ. 2)} \quad V_{\text{OA}} = 100 \times \left(\frac{V_{\text{OUT actual}} - V_{\text{OUT expected}}}{V_{\text{OUT expected}}} \right)$$

Example: Gain = 100, For 100mV V_{SENSE} input we measure 10.1V . The overall accuracy (V_{OA}) is 1% as shown in [Equation 3](#).

$$\text{(EQ. 3)} \quad V_{\text{OA}} = 100 \times \left(\frac{10.1 - 10}{10} \right) = 1\text{percent}$$

6.3 Power Dissipation

It is possible to exceed the +150°C maximum junction temperatures under certain load and power supply conditions. It is therefore important to calculate the maximum junction temperature (T_{JMAX}) for all applications to determine if power supply voltages, load conditions, or package type need to be modified to remain in the safe operating area. These parameters are related using [Equation 4](#):

$$(EQ. 4) \quad T_{JMAX} = T_{MAX} + \theta_{JA} \times PD_{MAXTOTAL}$$

where:

- $PD_{MAXTOTAL}$ is the sum of the maximum power dissipation of each amplifier in the package (PD_{MAX})
- PD_{MAX} for each amplifier can be calculated using [Equation 5](#):

$$(EQ. 5) \quad PD_{MAX} = V_S \times I_{qMAX} + (V_S - V_{OUTMAX}) \times \frac{V_{OUTMAX}}{R_L}$$

where:

- T_{MAX} = Maximum ambient temperature
- θ_{JA} = Thermal resistance of the package
- PD_{MAX} = Maximum power dissipation of 1 amplifier
- V_{CC} = Total supply voltage
- I_{qMAX} = Maximum quiescent supply current of 1 amplifier
- V_{OUTMAX} = Maximum output voltage swing of the application
- R_L = Load resistance

7. Package Outline Drawing

For the most recent package outline drawing, see [P5.064A](#).

P5.064A

5 Lead Small Outline Transistor Plastic Package

Rev 0, 2/10

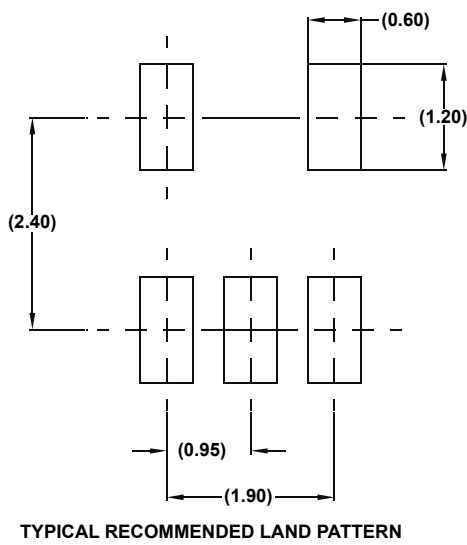
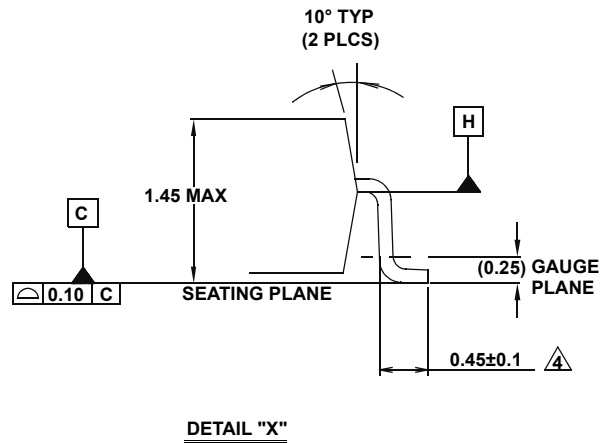
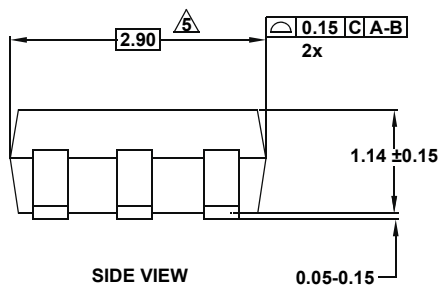
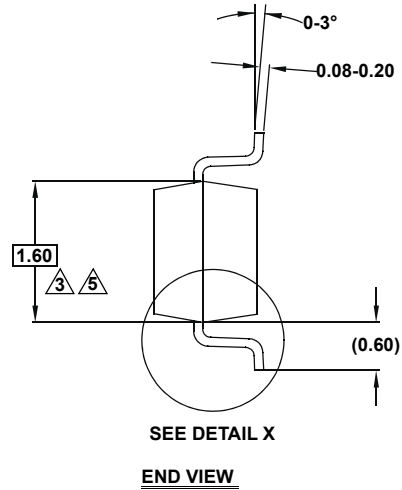
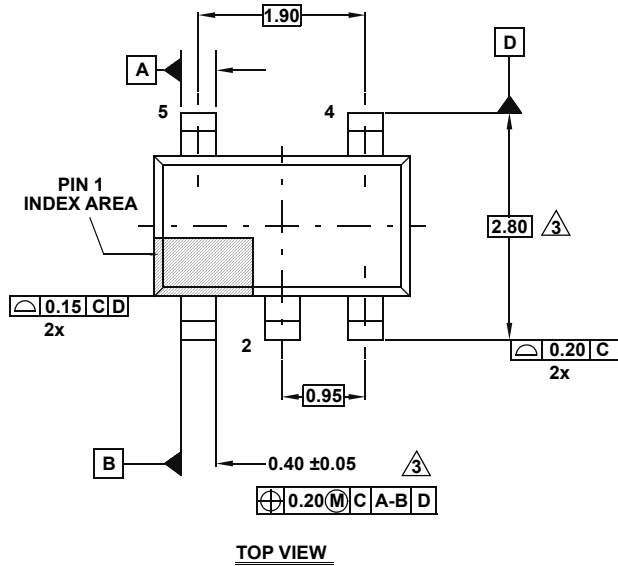

NOTES:

1. Dimensions are in millimeters.
Dimensions in () for Reference Only.
2. Dimensioning and tolerancing conform to ASME Y14.5M-1994.
3. Dimension is exclusive of mold flash, protrusions or gate burrs.
4. Foot length is measured at reference to gauge plane.
5. This dimension is measured at Datum "H".
6. Package conforms to JEDEC MO-178AA.

8. Ordering Information

Part Number ^{[1][2]}	Gain	Part Marking ^[3]	Package Description (RoHS Compliant)	PKG. DWG. #	Carrier Type ^[4]	Temp. Range
ISL28005FH100Z-T7	100V/V	BDEA	5 Ld SOT-23	P5.064A	Reel, 3k	-40 to +125°C
ISL28005FH100Z-T7A					Reel, 250	
ISL28005FH50Z-T7	50V/V	BDDA			Reel, 3k	
ISL28005FH50Z-T7A					Reel, 250	
ISL28005FH20Z-T7	20V/V	BDCA			Reel, 3k	
ISL28005FH20Z-T7A					Reel, 250	
ISL28005FH-100EVAL1Z	100V/V Evaluation Board					
ISL28005FH-50EVAL1Z	50V/V Evaluation Board					
ISL28005FH-20EVAL1Z	20V/V Evaluation Board					

- These Pb-free plastic packaged products employ special Pb-free material sets, molding compounds/die attach materials, and 100% matte tin plate plus anneal (e3 termination finish, which is RoHS compliant and compatible with both SnPb and Pb-free soldering operations). Pb-free products are MSL classified at Pb-free peak reflow temperatures that meet or exceed the Pb-free requirements of IPC/JEDEC J STD-020.
- For Moisture Sensitivity Level (MSL), see the [ISL28005](#) product page. For more information about MSL, see [TB363](#).
- The part marking is located on the bottom of the part.
- See [TB347](#) for details about reel specifications.

9. Revision History

Revision	Date	Change
6.01	Mar 3, 2022	Corrected the Output Resistance units from W back to ohms on page 6.
6.00	Feb 10, 2022	Applied New Template. Removed Related Literature and About Intersil sections. Updated Ordering Information table formatting. Updated Figures 1, Block Diagram, Pin Configuration, and figure in Pin description table. Updated Figure 21 through Figure 27, and Figure 29.
5.00	Oct 24, 2013	Added eight new Typical Performance Curves 1. Av = 100 Capacitive Load Drive Gain vs Freq 2. Av = 100 Capacitive Load Drive Phase vs Freq 3. Av = 50 Capacitive Load Drive Gain vs Freq 4. Av = 50 Capacitive Load Drive Phase vs Freq 5. Av = 20 Capacitive Load Drive Gain vs Freq 6. Av = 20 Capacitive Load Drive Phase vs Freq 7. High Side Operation Input Bias Currents 8. Low Side Operation Input Bias Currents Under Electrical Specifications Table: Changed parameter from Is to Icc to clarify supply current.
4.00	Apr 11, 2011	Corrected location of the load in Figure 27. Moved Load from the ground side of the input sense circuit to the high side of the voltage source. Updated note in Min Max column of spec table from "Parameters with MIN and/or MAX limits are 100% tested at +25°C, unless otherwise specified. Temperature limits established by characterization and are not production tested." to "Compliance to datasheet limits is assured by one or more methods: production test, characterization and/or design."
3.00	Sep 2, 2010	Added -T7A tape and reel package options to Ordering Information Table for all packages.

Revision	Date	Change
2.00	May 12, 2010	<p>Added Note 4 to Part Marking Column in Ordering Information table.</p> <p>Corrected hyperlinks in Notes 1 and 3 in Ordering Information table.</p> <p>Corrected ISL28005 hyperlink in "About Intersil" on page 15.</p> <p>Added Eval boards to ordering info.</p> <p>Added "Related Literature" on page 1</p> <p>Updated Package Drawing Number in the Ordering Information table from MDP0038 to P50.64A.</p> <p>Revised package outline drawing from MDP0038 to P5.064A. MDP0038 package contained 2 packages for both the 5 and 6 Ld SOT-23. MDP0038 was obsoleted and the packages were separated and made into 2 separate package outline drawings; P5.064A and P6.064A. Changes to the 5 Ld SOT-23 were to move dimensions from table onto drawing, add land pattern and add JEDEC reference number.</p>
1.00	Feb 3, 2010	<p>-Page 1: Edited last sentence of paragraph 2. Moved order of GAIN listings from 20, 50, 100 to 100, 50, 20 in the 3rd paragraph. Under Featuresremoved "Low Input Offset Voltage 250µV,max" Under Features moved order of parts listing from 20, 50, 100 (from top to bottom) to 100, 50, 20.</p> <p>-Page 3: Removed coming soon on ISL28005FH50Z and ISL28005FH20Z and changes the order or listing them to 100, 50, 20.</p> <p>-Page 5: VOA test. Under conditions column ...deleted "20mV to". It now reads ... Vsense = 100mV SR test. Under conditions column ..deleted what was there. It now reads ... Pulse on RS+pin, See Figure 25</p> <p>-Page 6: ts test. Removed Gain = 100 and Gain = 100V/V in both description and conditions columns respectively.</p> <p>-Page 9 Added Figure 25 and adjusted figure numbers to account for the added figure.</p>
0.00	Dec14, 2009	Initial Release