

HI1386

8-Bit, 75 MSPS, Flash A/D Converter

**OBSOLETE PRODUCT
NO RECOMMENDED REPLACEMENT**
contact our Technical Support Center at
1-888-INTERSIL or www.intersil.com/tsc

FN3583
Rev.5.00
March 2003

Features

- Differential Linearity Error ± 0.5 LSB or Less
- Integral Linearity Error ± 0.5 LSB or Less
- Built-In Integral Linearity Compensation Circuit
- High-Speed Operation with Maximum Conversion Rate (Min) 75 MSPS
- Low Input Capacitance (Typ)..... 17pF
- Wide Analog Input Bandwidth (Min for Full Scale Input) 150MHz
- Single Power Supply -5.2V
- Low Power Consumption (Typ) 580mW
- Low Error Rate
- Operable at 50% Clock Duty Cycle
- Capable of Driving 50 Ω Loads
- Direct Replacement for CXA1386

Applications

- Video Digitizing
- RGB Graphics Processing
- HDTV (High Definition TV)
- Radar Systems
- Communication Systems
- Direct RF Down-Conversion
- Digital Oscilloscopes

Description

The HI1386 is an 8-bit, high-speed flash analog-to-digital converter IC capable of digitizing analog signals at a maximum rate of 75 MSPS. The digital I/O levels of this A/D converter are compatible with ECL 100K/10KH/10K.

The HI1386 is available in the commercial and industrial temperature range and is supplied in 28 lead plastic DIP and 44 lead ceramic LCC packages.

Part Number Information

PART NUMBER	TEMP. RANGE (°C)	PACKAGE	PKG. NO.
HI1386JCP	-20 to 75	28 Ld PDIP	E28.6A-S
HI1386AIL	-20 to 100	44 Ld CLCC	J44.B

Pinouts

HI1386 (PDIP)
TOP VIEW

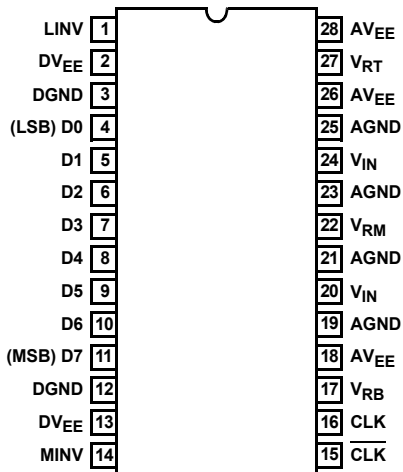

HI1386 (CLCC)
TOP VIEW

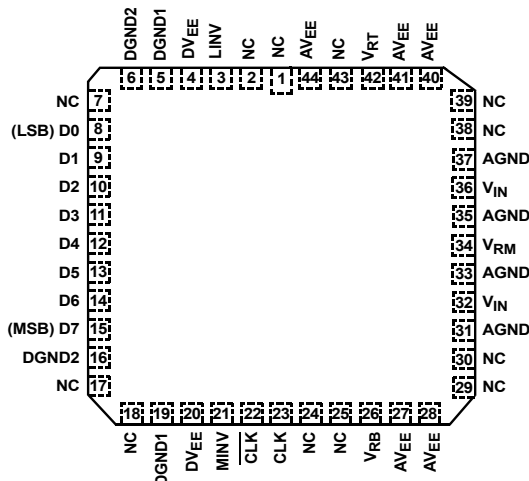

Functional Block Diagram

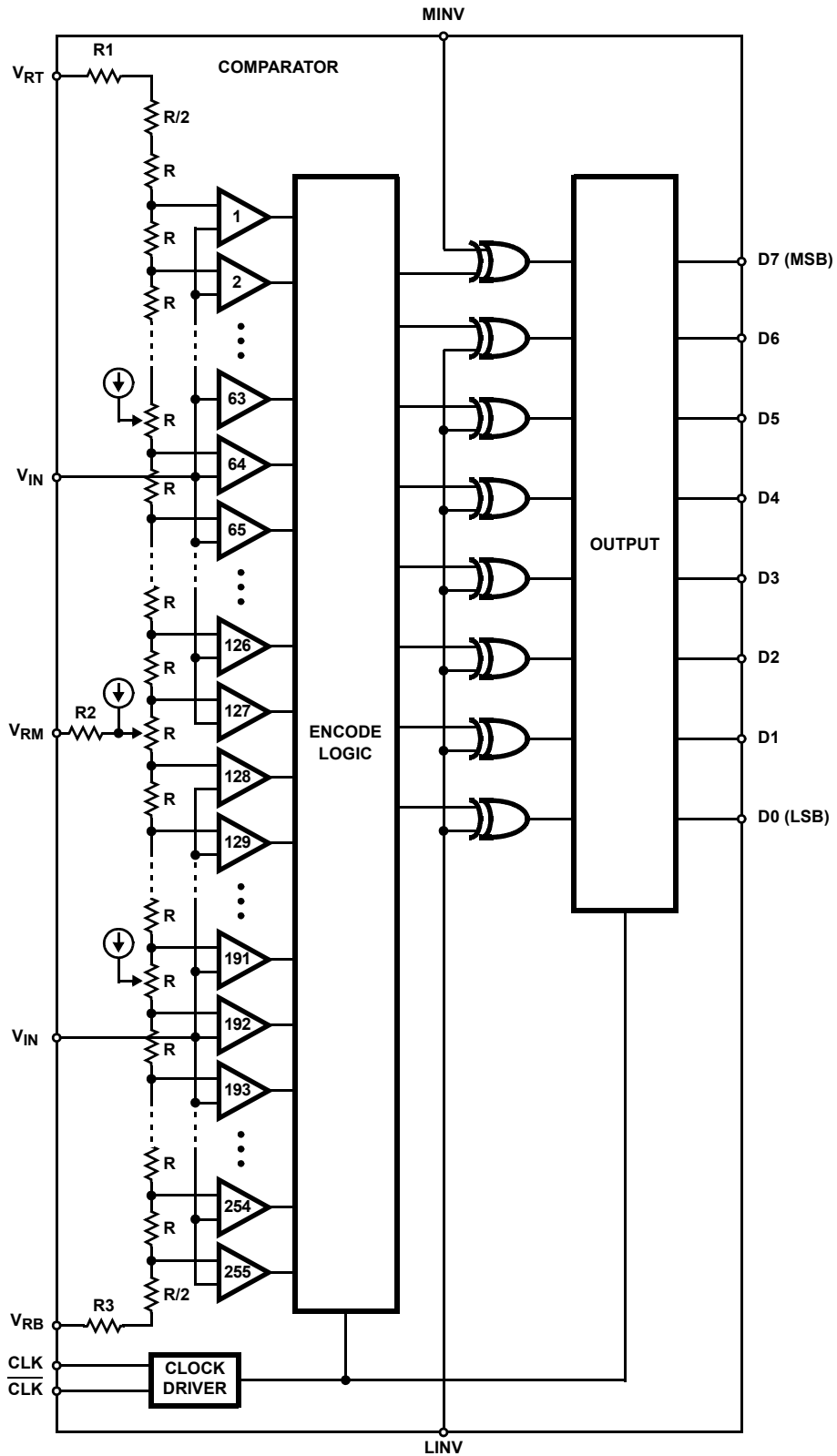

Pin Descriptions

PIN NUMBER		SYMBOL	I/O	STANDARD VOLTAGE LEVEL	EQUIVALENT CIRCUIT	DESCRIPTION
DIP	LCC					
19, 21, 23, 25	31, 33, 35, 37	AGND	-	0V		Analog GND. Used as GND for input buffers and latches of comparators. Isolated from DGND, DGND1, and DGND2.
18, 26, 28	27, 28, 40, 41, 44	AV _{EE}	-	-5.2V		Analog V _{EE} -5.2V (Typ). Internally connected to DV _{EE} (Resistance: 4Ω to 6Ω). Bypass with 0.1μF to AGND.
16	23	CLK	I	ECL		CLK Input.
15	22	$\overline{\text{CLK}}$				Input Complementary to CLK. When open pulled down to -1.3V. Device is operable without CLK input, but use of complementary inputs of CLK and $\overline{\text{CLK}}$ is recommended to obtain stable high speed operation.
3, 12	-	DGND	-	0V		Digital GND (used for internal circuits and output transistors).
-	5, 19	DGND1	-	0V		Digital GND (used for internal circuits and output transistors).
-	6, 16	DGND2	-	0V		Digital GND (used for output buffers).
2, 13	4, 20	DV _{EE}	-	-5.2V		Digital V _{EE} . Internally connected to AV _{EE} (resistance: 4Ω to 6Ω). Bypass with 0.1μF to DGND
4	8	D0	O	ECL		LSB of Data Outputs. External pull-down resistor is required.
5	9	D1				Data Outputs. External pull-down resistors are required.
6	10	D2				
7	11	D3				
8	12	D4				
9	13	D5				
10	14	D6				
11	15	D7	MSB of Data Outputs. External pull-down resistor is required.			

Pin Descriptions (Continued)

PIN NUMBER		SYMBOL	I/O	STANDARD VOLTAGE LEVEL	EQUIVALENT CIRCUIT	DESCRIPTION
DIP	LCC					
1	3	LINV	I	ECL		<p>Input Pin for D0 (LSB) to D6 Output Polarity Inversion (see A/D Output Code Table). Pulled low when left open.</p> <p>Input Pin for D7 (MSB) Output Polarity Inversion (see A/D Output Code Table). Pulled low when left open.</p>
20, 24	32, 36	V_{IN}	I	V_{RT} to V_{RB}		<p>Analog Input Pins. These two pins must be connected externally, since they are not internally connected. See Application Note for precautions.</p>
17	26	V_{RB}	I	-2V		<p>Reference Voltage (Bottom). Typically -2V. Bypass with a 0.1μF and 10μF to AGND.</p>
22	34	V_{RM}	I	$V_{RB}/2$		<p>Reference Voltage Mid Point. Can be used as a pin for integral linearity compensation.</p>
27	42	V_{RT}	I	0V		<p>Reference Voltage (Top) Typically 0V.</p>

Absolute Maximum Ratings $T_A = 25^{\circ}\text{C}$

Supply Voltage (V_{EE}, DV_{EE})	-7V to +0.5V
Analog Input Voltage (V_{IN})	-2.7V to +0.5V
Reference Input Voltage	
V_{RT}, V_{RB}, V_{RM}	-2.7V to +0.5V
$ V_{RT} - V_{RB} $	2.5V
Digital Input Voltage	
CLK, $\overline{\text{CLK}}$, MINV, LINV	-4V to +0.5V
$ \text{CLK} - \overline{\text{CLK}} $	2.7V
V_{RM} Pin Input Current (I_{VRM})	-3mA to +3mA
Digital Output Current (ID0 to ID7)	-30mA to 0mA

Operating Conditions

Temperature Ranges (Note 4)	
PDIP Package (T_A)	-20 $^{\circ}\text{C}$ to 75 $^{\circ}\text{C}$
CLCC Package (T_C)	-20 $^{\circ}\text{C}$ to 100 $^{\circ}\text{C}$
Supply Voltage	
V_{EE}, DV_{EE}	-5.5V to -4.95V
$V_{EE} - DV_{EE}$	-0.05V to 0.05V
AGND - DGND	-0.05V to 0.05V
Reference Input Voltage	
V_{RT}	-0.1V to 0.1V
V_{RB}	-2.2V to -1.8V

Thermal Information

Thermal Resistance (Typical, Note 1)	θ_{JA} $^{\circ}\text{C}/\text{W}$	θ_{JC} $^{\circ}\text{C}/\text{W}$
PDIP Package	58	N/A
CLCC Package	45	11
Maximum Junction Temperature		
CLCC Package		175 $^{\circ}\text{C}$
PDIP Package		150 $^{\circ}\text{C}$
Maximum Storage Temperature Range (T_{STG})		-65 $^{\circ}\text{C}$ to 150 $^{\circ}\text{C}$
Maximum Lead Temperature (Soldering 10s)		300 $^{\circ}\text{C}$

Analog Input Voltage, V_{IN}	V_{RB} to V_{RT}
Pulse Width of Clock	
t_{PW1}	6.6ns (Min)
t_{PW0}	6.6ns (Min)

CAUTION: Stresses above those listed in "Absolute Maximum Ratings" may cause permanent damage to the device. This is a stress only rating and operation of the device at these or any other conditions above those indicated in the operational sections of this specification is not implied.

NOTE:

- θ_{JA} is measured with the component mounted on an evaluation PC board in free air.

Electrical Specifications $T_A = 25^{\circ}\text{C}, V_{EE} = DV_{EE} = -5.2\text{V}, V_{RT} = 0\text{V}, V_{RB} = -2\text{V}$ (Note 1)

PARAMETER	TEST CONDITIONS	MIN	TYP	MAX	UNIT
SYSTEM PERFORMANCE					
Resolution		-	8	-	Bits
Integral Linearity Error, INL	$f_C = 75\text{MHz}$	-	± 0.3	± 0.5	LSB
Differential Linearity Error, DNL	$f_C = 75\text{MHz}$	-	± 0.3	± 0.5	LSB
DYNAMIC CHARACTERISTICS					
Signal to Noise and Distortion Ratio, SINAD = $\frac{\text{RMS Signal}}{\text{RMS Noise} + \text{Distortion}}$	Input = 1MHz, Full Scale $f_C = 75\text{MHz}$	-	46	-	dB
	Input = 18.75MHz, Full Scale $f_C = 75\text{MHz}$	-	40	-	dB
Error Rate	Input = 18.749MHz, Full Scale Error > 16 LSB, $f_C = 75\text{MHz}$	-	-	10^{-9}	TPS (Note 2)
Differential Gain Error, DG	NTSC 40 IRE Mod. Ramp, $f_C = 75\text{MSPS}$	-	1.0	-	%
Differential Phase Error, DP		-	0.5	-	Degree
Maximum Conversion Rate, f_C	Error Rate of 10^{-9} TPS (Note 2)	75	-	-	MSPS
Aperture Jitter, t_{AJ}		-	10	-	ps
Sampling Delay, t_{DS}		-	3.0	-	ns
ANALOG INPUT					
Input Bandwidth	$V_{IN} = 2V_{P-P}$ (-3dB)	150	-	-	MHz
Analog Input Capacitance, C_{IN}	$V_{IN} = 1\text{V} + 0.07V_{RMS}$	-	17	-	pF
Analog Input Resistance, R_{IN}		-	390	-	k Ω
Input Bias Current, I_{IN}	$V_{IN} = -1\text{V}$	-	-	200	μA
REFERENCE INPUTS					
Reference Resistance, R_{REF}		75	110	155	Ω

Electrical Specifications $T_A = 25^{\circ}\text{C}$, $AV_{EE} = DV_{EE} = -5.2\text{V}$, $V_{RT} = 0\text{V}$, $V_{RB} = -2\text{V}$ (Note 1) (Continued)

PARAMETER	TEST CONDITIONS	MIN	TYP	MAX	UNIT
Offset Voltage					
E_{OT}	V_{RT}	8	18	32	mV
E_{OB}	V_{RB}	0	10	24	mV
DIGITAL INPUTS					
Logic H Level, V_{IH}		-1.13	-	-	V
Logic L Level, V_{IL}		-	-	-1.50	V
Logic H Current, I_{IH}	-0.8V is Applied to Input	0	-	50	μA
Logic L Current, I_{IL}	-1.6V is Applied to Input	-50	-	50	μA
Input Capacitance		-	7	-	pF
DIGITAL OUTPUTS					
Logic H Level, V_{OH}	$R_L = 620\Omega$ to DV_{EE}	-1.03	-	-	V
Logic L Level, V_{OL}	$R_L = 620\Omega$ to DV_{EE}	-	-	-1.62	V
TIMING CHARACTERISTICS					
H Pulse Width of Clock, t_{PW1}		6.6	-	-	ns
L Pulse Width of Clock, t_{PW0}		6.6	-	-	ns
Output Rise Time, t_r	$R_L = 620\Omega$ to DV_{EE} , 20% to 80%	-	0.9	-	ns
Output Fall Time, t_f	$R_L = 620\Omega$ to DV_{EE} , 20% to 80%	-	2.1	-	ns
Output Delay, t_{OD}		4.0	6.5	9.0	ns
POWER SUPPLY CHARACTERISTICS					
Supply Current, I_{EE}		-150	-104	-	mA
Power Consumption, P_D	Note 3	-	580	-	mW

NOTES:

1. Electrical Specifications guaranteed within stated operating conditions.
2. TPS: Times Per Sample.
3.
$$P_D = I_{EE} \cdot V_{EE} + \frac{(V_{RT} - V_{RB})^2}{R_{REF}}$$
4. T_A specified in still air and without heat sink. To extend temperature range, appropriate heat management techniques must be employed.

Timing Diagram

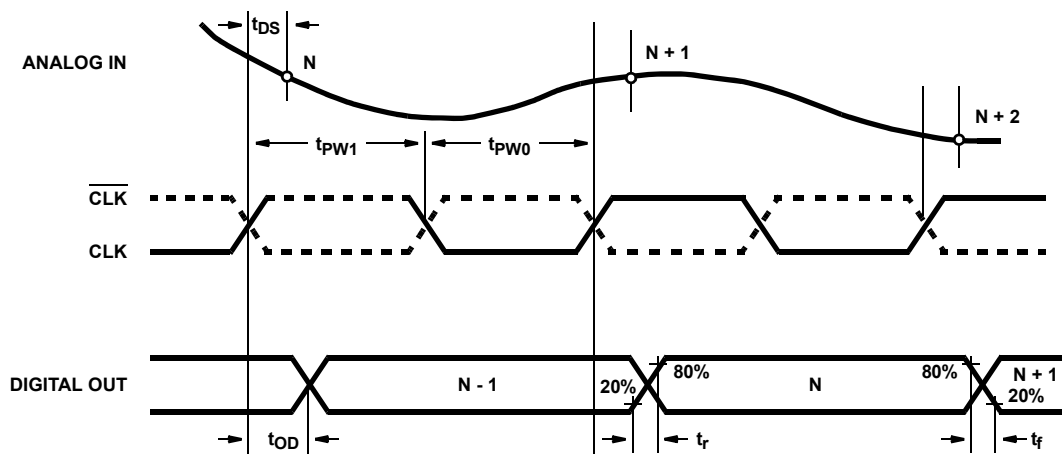

FIGURE 1.

A/D OUTPUT CODE TABLE

V_{IN} (NOTE 1)	STEP	MINV 1 LINV 1		0 1		1 0		0 0	
		D7	D0	D7	D0	D7	D0	D7	D0
0V	0	000 ••••• 00	100 ••••• 00	011 ••••• 11	111 ••••• 11				
		000 ••••• 00	100 ••••• 00	011 ••••• 11	111 ••••• 11				
		000 ••••• 01	100 ••••• 01	011 ••••• 10	111 ••••• 10				
-1V	127	•	•	•	•				
		•	•	•	•				
		•	•	•	•				
	128	011 ••••• 11	111 ••••• 11	000 ••••• 00	100 ••••• 00				
		100 ••••• 00	000 ••••• 00	111 ••••• 11	011 ••••• 11				
		•	•	•	•				
254	111 ••••• 10	011 ••••• 10	100 ••••• 01	000 ••••• 01					
	111 ••••• 11	011 ••••• 11	100 ••••• 00	000 ••••• 00					
-2V		111 ••••• 11	011 ••••• 11	100 ••••• 00	000 ••••• 00				

NOTE:

5. $V_{RT} = 0V$, $V_{RB} = -2V$.

© Copyright Intersil Americas LLC 1997-2003. All Rights Reserved.
All trademarks and registered trademarks are the property of their respective owners.

For additional products, see www.intersil.com/en/products.html

Intersil products are manufactured, assembled and tested utilizing ISO9001 quality systems as noted in the quality certifications found at www.intersil.com/en/support/qualandreliability.html

Intersil products are sold by description only. Intersil may modify the circuit design and/or specifications of products at any time without notice, provided that such modification does not, in Intersil's sole judgment, affect the form, fit or function of the product. Accordingly, the reader is cautioned to verify that datasheets are current before placing orders. Information furnished by Intersil is believed to be accurate and reliable. However, no responsibility is assumed by Intersil or its subsidiaries for its use; nor for any infringements of patents or other rights of third parties which may result from its use. No license is granted by implication or otherwise under any patent or patent rights of Intersil or its subsidiaries.

For information regarding Intersil Corporation and its products, see www.intersil.com