

HA-2640, HA-2645

4MHz, High Supply Voltage Operational Amplifiers

FN2904  
Rev 6.00  
August 7, 2015

HA-2640 and HA-2645 are monolithic operational amplifiers which are designed to deliver unprecedented dynamic specifications for a high voltage internally compensated device. These dielectrically isolated devices offer very low values for offset voltage and offset current coupled with large output voltage swing and common mode input voltage.

For maximum reliability, these amplifiers offer unconditional output overload protection through current limiting and a chip temperature sensing circuit. This sensing device turns the amplifier "off", when the chip reaches a certain temperature level.

These amplifiers deliver  $\pm 35V$  common mode input voltage range,  $\pm 35V$  output voltage swing, and up to  $\pm 40V$  supply range for use in such designs as regulators, power supplies, and industrial control systems. 4MHz gain bandwidth and  $5V/\mu s$  slew rate make these devices excellent components for high performance signal conditioning applications. Outstanding input and output voltage swings coupled with a low 5nA offset current make these amplifiers excitation designs.

**Features**

- Output Voltage Swing . . . . .  $\pm 35V$
- Supply Voltage . . . . .  $\pm 10V$  to  $\pm 40V$
- Offset Current. . . . . 5nA
- Bandwidth . . . . . 4MHz
- Slew Rate. . . . .  $5V/\mu s$
- Common Mode Input Voltage Range. . . . .  $\pm 35V$
- Output Overload Protection

**Applications**

- Industrial Control Systems
- Power Supplies
- High Voltage Regulators
- Resolver Excitation
- Signal Conditioning

**Ordering Information**

PART NUMBER	PART MARKING	TEMP. RANGE (°C)	PACKAGE	PKG. DWG. #
HA2-2640-2	HA2-2640-2	-55 to 125	8 Pin Metal Can	T8.C
HA7-2640-2	HA7-2640-2	-55 to 125	8 Ld CERDIP	F8.3A
HA2-2645-5 (No longer available or supported)	HA2-2645-5	0 to 75	8 Pin Metal Can	T8.C
HA7-2645-5 (No longer available or supported)	HA7-2645-5	0 to 75	8 Ld CERDIP	F8.3A

**Pinouts**

HA-2640/2645  
(CERDIP)  
TOP VIEW

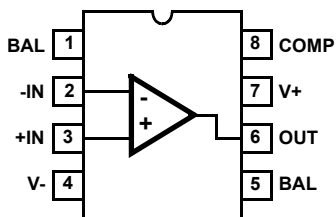

HA-2640/2645  
(METAL CAN)  
TOP VIEW

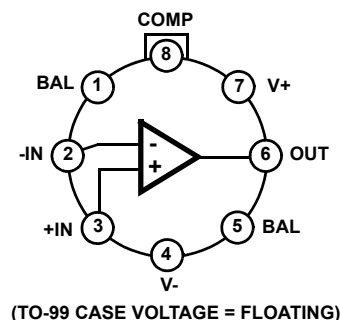

**Absolute Maximum Ratings**

Voltage Between V+ and V- Terminals ..... 100V  
 Differential Input Voltage Range ..... 37V  
 Output Current ..... Full Short Circuit Protection

**Operating Conditions**

Temperature Range  
 HA-2640-2 ..... -55°C to 125°C  
 HA-2645-5 ..... 0°C to 75°C

*CAUTION: Stresses above those listed in "Absolute Maximum Ratings" may cause permanent damage to the device. This is a stress only rating and operation of the device at these or any other conditions above those indicated in the operational sections of this specification is not implied.*

**NOTE:**

1.  $\theta_{JA}$  is measured with the component mounted on an evaluation PC board in free air.

**Thermal Information**

Thermal Resistance (Typical, Note 1)  $\theta_{JA}$  (°C/W)  $\theta_{JC}$  (°C/W)  
 CERDIP Package ..... 135 50  
 Metal Can Package ..... 165 80  
 Maximum Junction Temperature ..... 175°C  
 Maximum Storage Temperature Range ..... -65°C to 150°C  
 Maximum Lead Temperature (Soldering 10s) ..... 300°C

**Electrical Specifications**  $V_{SUPPLY} = \pm 40V$ ,  $R_L = 5k\Omega$ , Unless Otherwise Specified

PARAMETER	TEST CONDITIONS	TEMP (°C)	HA-2640-2			HA-2645-5			UNITS
			MIN	TYP	MAX	MIN	TYP	MAX	
<b>INPUT CHARACTERISTICS</b>									
Offset Voltage		25	-	2	4	-	2	6	mV
		Full		-	6	-	-	7	mV
Average Offset Voltage Drift		Full	-	15	-	-	15	-	$\mu V/^\circ C$
Bias Current		25	-	10	25	-	12	30	nA
		Full	-	-	50	-	-	50	nA
Offset Current		25	-	5	12	-	15	30	nA
		Full	-	-	35	-	-	50	nA
Input Resistance (Note 2)		25	50	250	-	40	200	-	M $\Omega$
Common Mode Range		Full	$\pm 35$	-	-	$\pm 35$	-	-	V
<b>TRANSFER CHARACTERISTICS</b>									
Large Signal Voltage Gain	$V_{OUT} = \pm 30V$	25	100	200	-	100	200	-	kV/V
		Full	75	-	-	75	-	-	kV/V
Common Mode Rejection Ratio	$V_{CM} = \pm 20V$	Full	80	100	-	74	100	-	dB
Minimum Stable Gain		25	1	-	-	1	-	-	V/V
Unity Gain Bandwidth	$V_{OUT} = 90mV$	25	-	4	-	-	4	-	MHz
<b>OUTPUT CHARACTERISTICS</b>									
Output Voltage Swing		Full	$\pm 35$	-	-	$\pm 35$	-	-	V
Output Current	$R_L = 1k\Omega$	25	$\pm 12$	$\pm 15$	-	$\pm 10$	$\pm 12$	-	mA
Output Resistance	Open Loop	25	-	500	-	-	500	-	$\Omega$
Full Power Bandwidth (Note 3)	$V_{OUT} = \pm 35V$	25	-	23	-	-	23	-	kHz
<b>TRANSIENT RESPONSE</b> $A_V = +1$ , $C_L = 50pF$ , $R_L = 5k\Omega$									
Rise Time	$V_{OUT} = \pm 200mV$	25	-	60	135	-	60	135	ns
Overshoot	$V_{OUT} = \pm 200mV$	25	-	15	30		15	40	%
Slew Rate		25	$\pm 3$	$\pm 5$	-	$\pm 2.5$	$\pm 5$	-	V/ $\mu s$
<b>POWER SUPPLY CHARACTERISTICS</b>									
Supply Current		25	-	3.2	3.8	-	3.2	4.5	mA
Supply Voltage Range		Full	$\pm 10$	-	$\pm 40$	$\pm 10$	-	$\pm 40$	V
Power Supply Rejection Ratio	$V_S = \pm 10V$ to $\pm 40V$	Full	80	90	-	74	90	-	dB

**NOTES:**

2. This parameter is based upon design calculations.
3. Full Power Bandwidth guaranteed based upon slew rate measurement:  $FPBW = S.R./2\pi V_{PEAK}$ ;  $V_{PEAK} = 35V$ .

**Schematic Diagram**

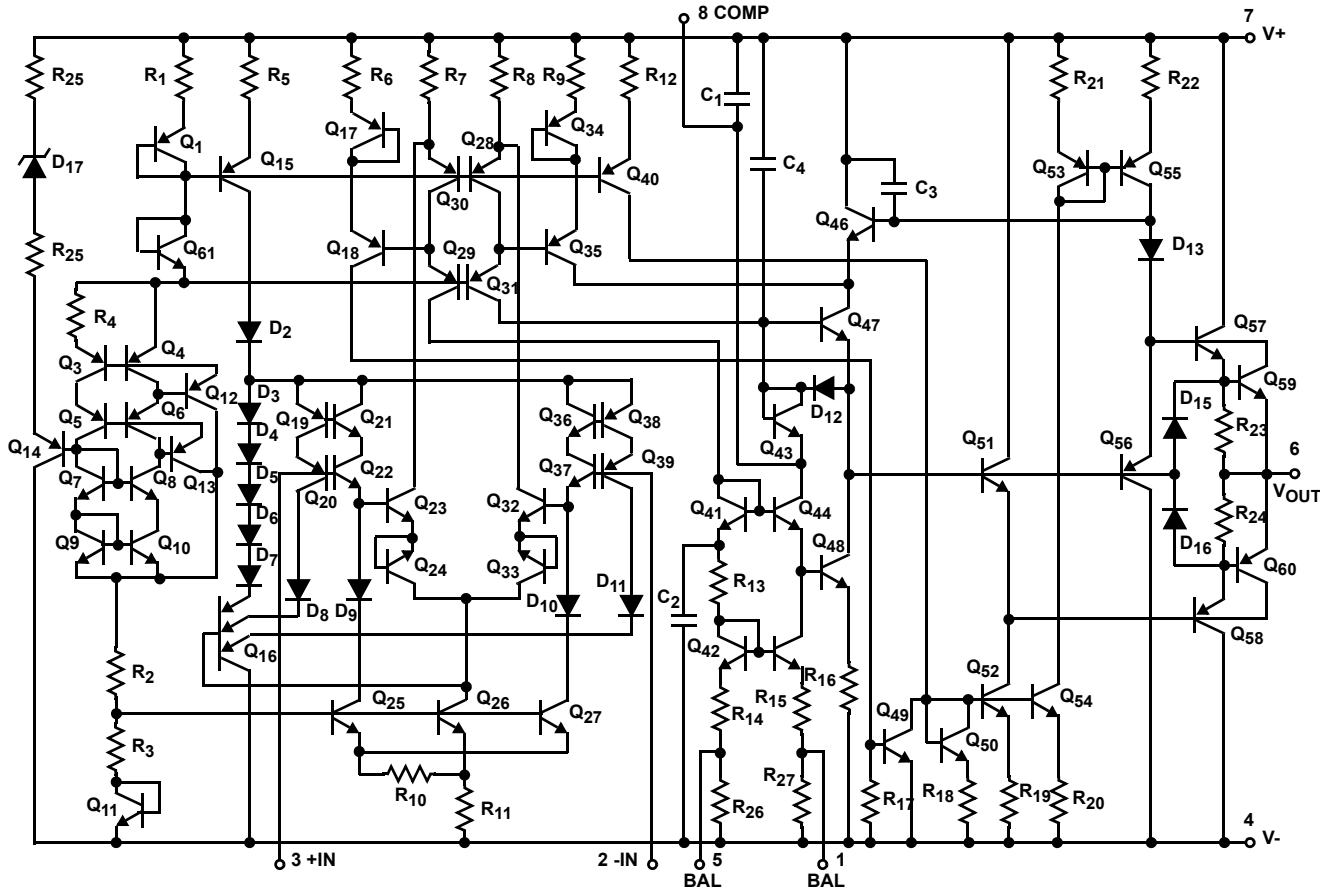

**Test Circuits and Waveform**

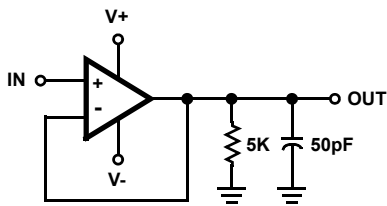

**FIGURE 1. SLEW RATE AND TRANSIENT RESPONSE TEST CIRCUIT**

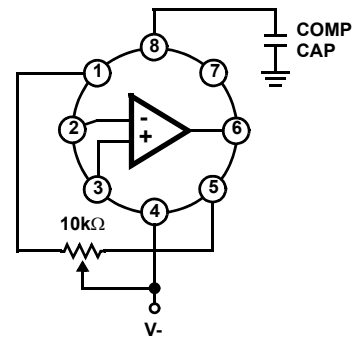

NOTE: Tested offset adjustment range is  $|V_{OS} + 1mV|$  minimum referred to output. Typical range is  $\pm 20mV$  with  $R_T = 10k\Omega$ .

**FIGURE 2. SUGGESTED  $V_{OS}$  ADJUSTMENT AND COMPENSATION HOOK UP**

**Test Circuits and Waveform** (Continued)

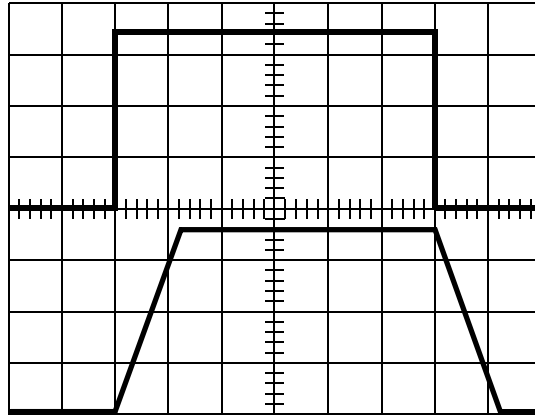

Vertical = 10V/Div., Horizontal = 5μs/Div.

NOTE:  $R_L = 5k\Omega$ ,  $C_L = 50pF$ ,  $T_A = 25^\circ C$ ,  $V_S = \pm 40V$

**FIGURE 3. VOLTAGE FOLLOWER PULSE RESPONSE**

**Typical Performance Curves**  $V_S = \pm 40V$ ,  $T_A = 25^\circ C$ , Unless Otherwise Specified

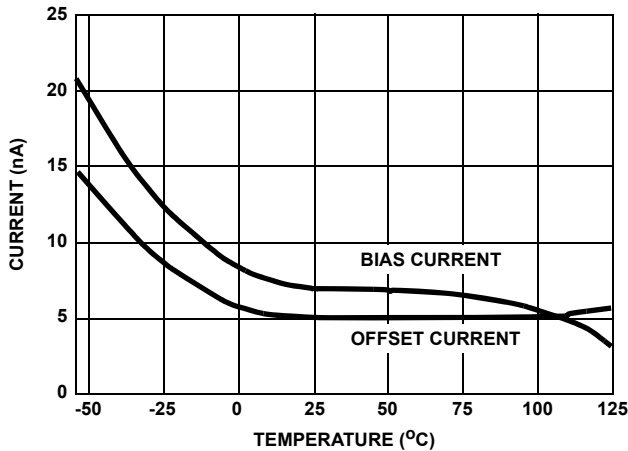

**FIGURE 4. INPUT BIAS AND OFFSET CURRENT vs TEMPERATURE**

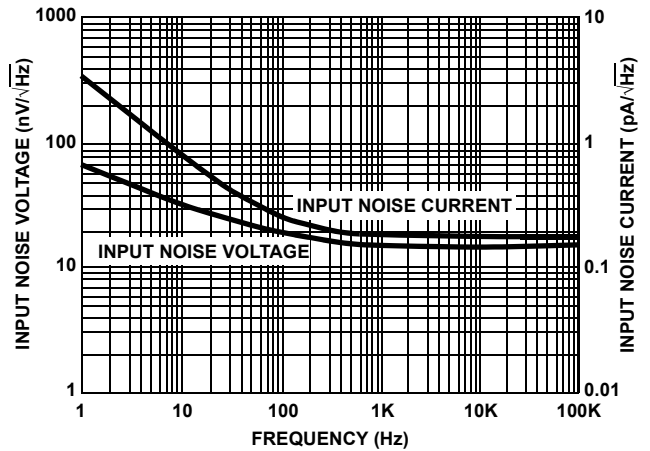

**FIGURE 5. INPUT NOISE CHARACTERISTICS**

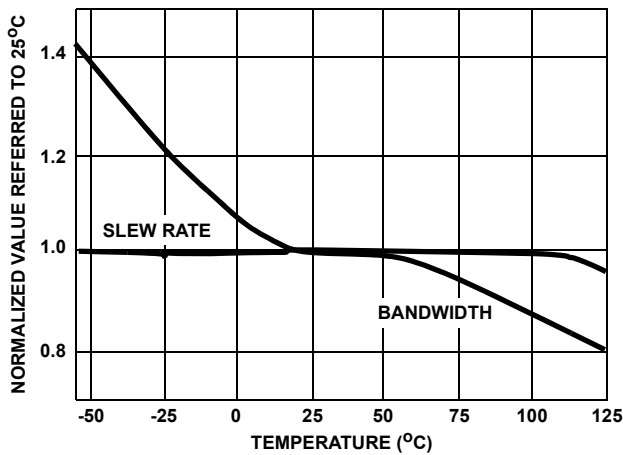

**FIGURE 6. NORMALIZED AC PARAMETERS vs TEMPERATURE**

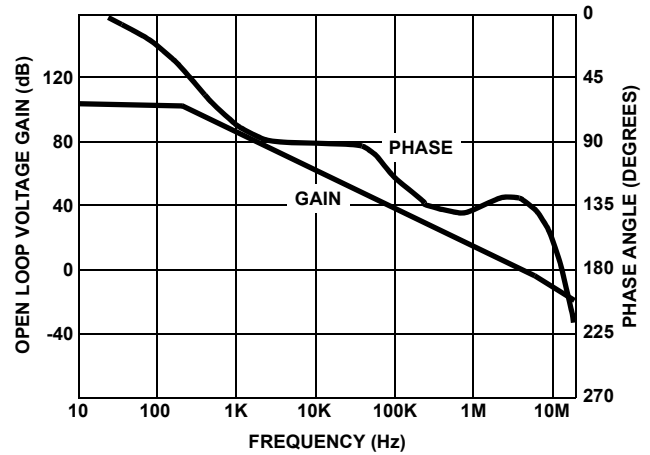

**FIGURE 7. OPEN LOOP FREQUENCY RESPONSE**

**Typical Performance Curves**  $V_S = \pm 40V$ ,  $T_A = 25^\circ C$ , Unless Otherwise Specified (Continued)

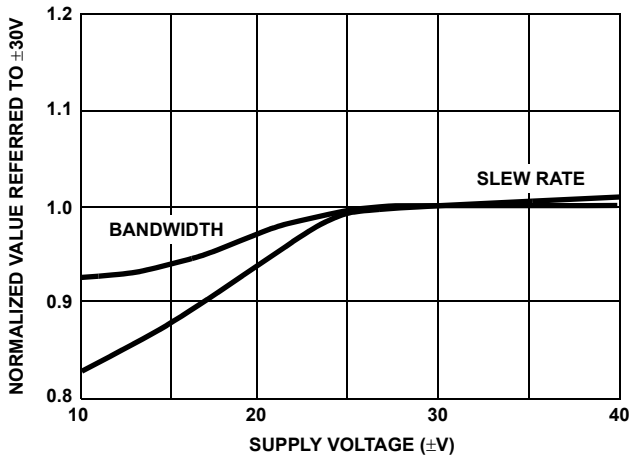

FIGURE 8. NORMALIZED AC PARAMETERS vs SUPPLY VOLTAGE AT 25°C

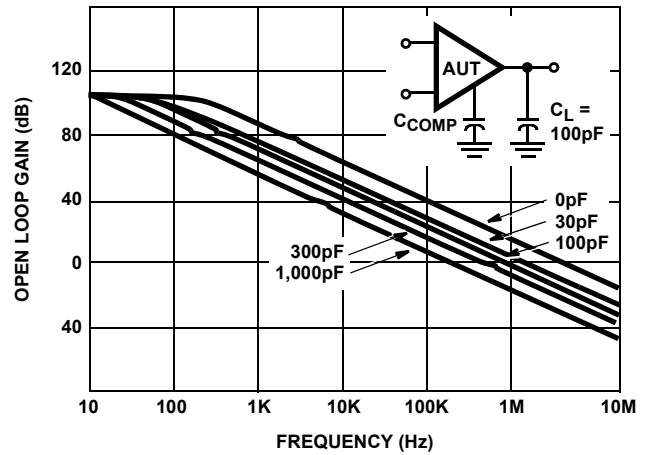

FIGURE 9. OPEN LOOP FREQUENCY RESPONSE FOR VARIOUS VALUES OF CAPACITORS FROM COMPENSATION PIN TO GROUND

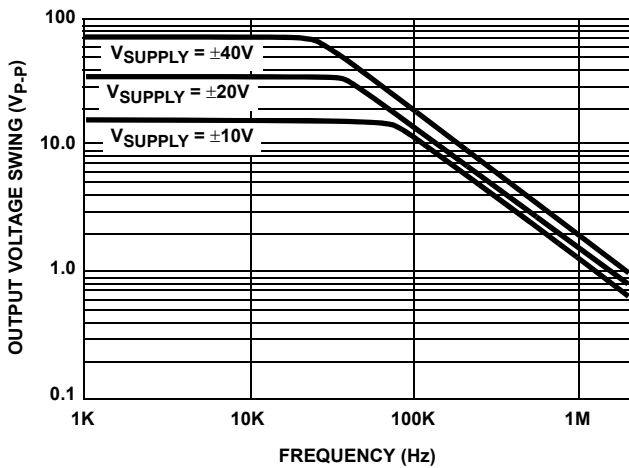

FIGURE 10. OUTPUT VOLTAGE SWING vs FREQUENCY

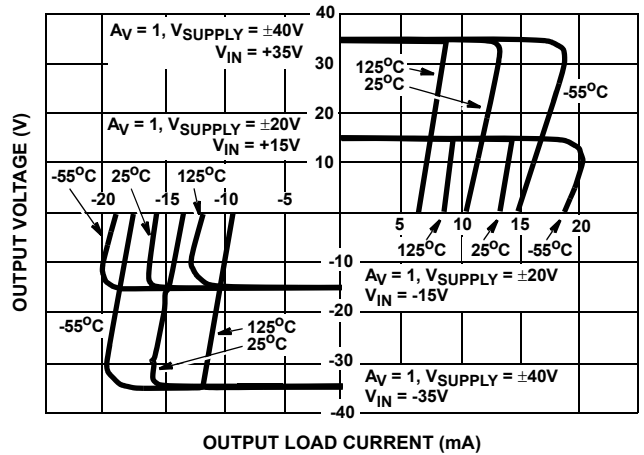

FIGURE 11. OUTPUT CURRENT CHARACTERISTIC

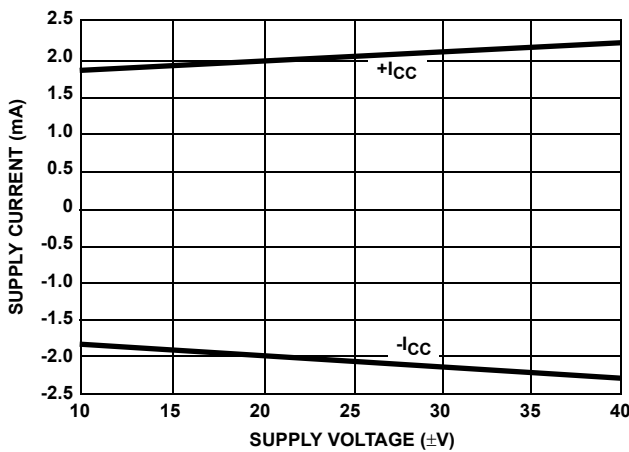

FIGURE 12. SUPPLY CURRENT vs SUPPLY VOLTAGE

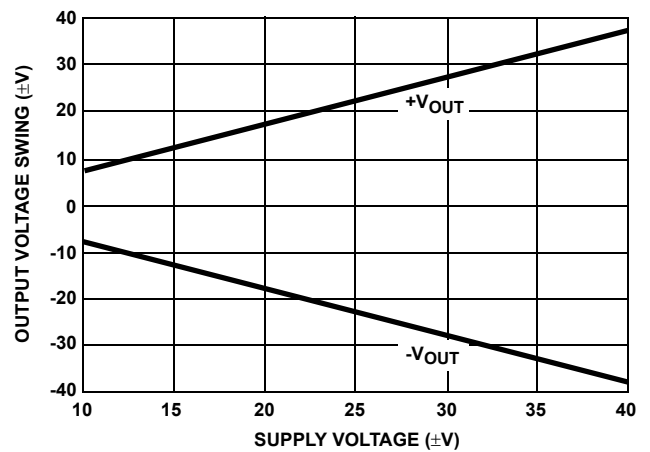

FIGURE 13. OUTPUT VOLTAGE SWING vs SUPPLY VOLTAGE

## Die Characteristics

### SUBSTRATE POTENTIAL (Powered Up):

Unbiased

### TRANSISTOR COUNT:

76

### PROCESS:

HV200 Bipolar Dielectric Isolation

## Metallization Mask Layout

HA-2640, HA-2645

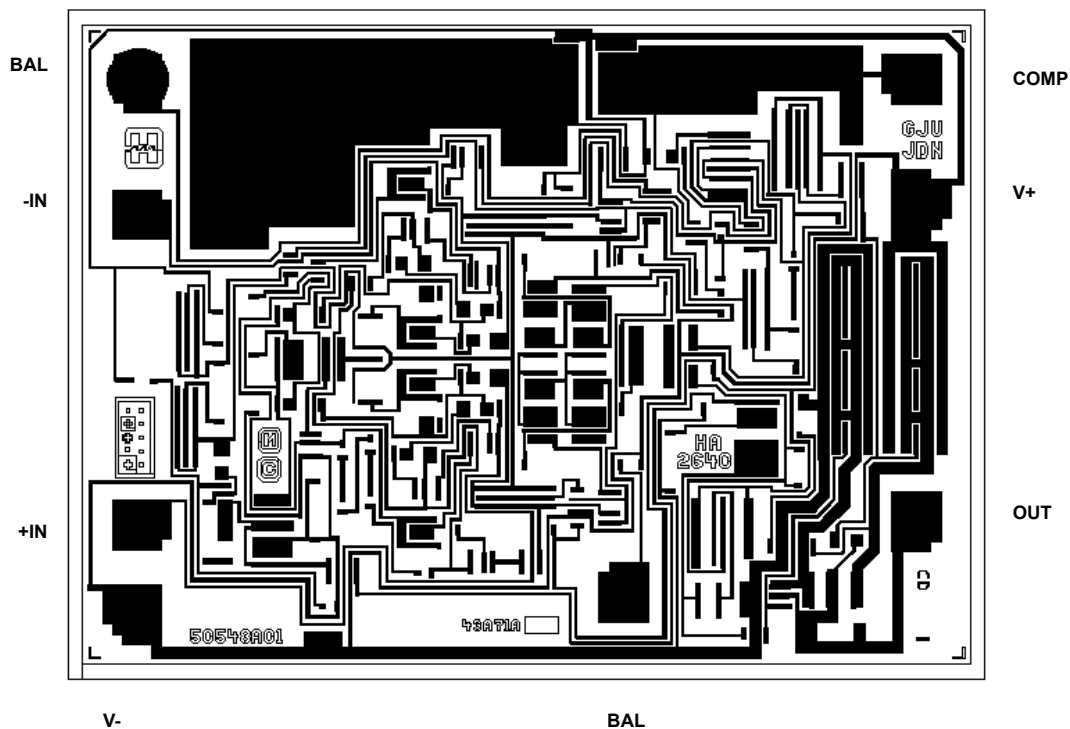

---

## Revision History

The revision history provided is for informational purposes only and is believed to be accurate, but not warranted. Please go to the web to make sure that you have the latest revision.

DATE	REVISION	CHANGE
August 7, 2015	FN2904.6	Page 1, Ordering Information table: HA2-2645-5 and HA7-2645-5 no longer available or supported. Added Revision History and About Intersil.

---

## About Intersil

Intersil Corporation is a leading provider of innovative power management and precision analog solutions. The company's products address some of the largest markets within the industrial and infrastructure, mobile computing and high-end consumer markets.

For the most updated datasheet, application notes, related documentation and related parts, please see the respective product information page found at [www.intersil.com](http://www.intersil.com).

You may report errors or suggestions for improving this datasheet by visiting [www.intersil.com/ask](http://www.intersil.com/ask).

Reliability reports are also available from our website at [www.intersil.com/support](http://www.intersil.com/support)

### Metal Can Packages (Can)

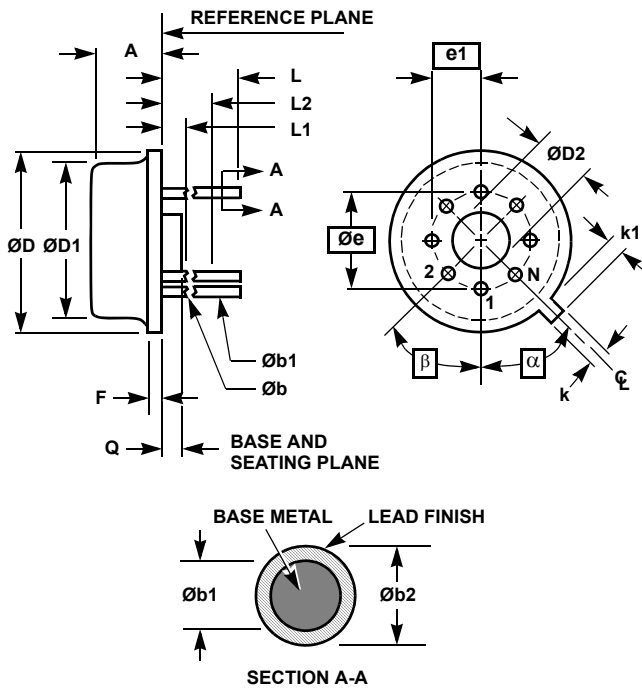

**NOTES:**

1. (All leads)  $\varnothing b$  applies between  $L1$  and  $L2$ .  $\varnothing b1$  applies between  $L2$  and 0.500 from the reference plane. Diameter is uncontrolled in  $L1$  and beyond 0.500 from the reference plane.
2. Measured from maximum diameter of the product.
3.  $\alpha$  is the basic spacing from the centerline of the tab to terminal 1 and  $\beta$  is the basic spacing of each lead or lead position ( $N - 1$  places) from  $\alpha$ , looking at the bottom of the package.
4.  $N$  is the maximum number of terminal positions.
5. Dimensioning and tolerancing per ANSI Y14.5M - 1982.
6. Controlling dimension: INCH.

**T8.C MIL-STD-1835 MACY1-X8 (A1)  
8 LEAD METAL CAN PACKAGE**

SYMBOL	INCHES		MILLIMETERS		NOTES
	MIN	MAX	MIN	MAX	
A	0.165	0.185	4.19	4.70	-
$\varnothing b$	0.016	0.019	0.41	0.48	1
$\varnothing b1$	0.016	0.021	0.41	0.53	1
$\varnothing b2$	0.016	0.024	0.41	0.61	-
$\varnothing D$	0.335	0.375	8.51	9.40	-
$\varnothing D1$	0.305	0.335	7.75	8.51	-
$\varnothing D2$	0.110	0.160	2.79	4.06	-
e	0.200 BSC		5.08 BSC		-
e1	0.100 BSC		2.54 BSC		-
F	-	0.040	-	1.02	-
k	0.027	0.034	0.69	0.86	-
k1	0.027	0.045	0.69	1.14	2
L	0.500	0.750	12.70	19.05	1
L1	-	0.050	-	1.27	1
L2	0.250	-	6.35	-	1
Q	0.010	0.045	0.25	1.14	-
$\alpha$	45° BSC		45° BSC		3
$\beta$	45° BSC		45° BSC		3
N	8		8		4

Rev. 0 5/18/94



**Ceramic Dual-In-Line Frit Seal Packages (CERDIP)**

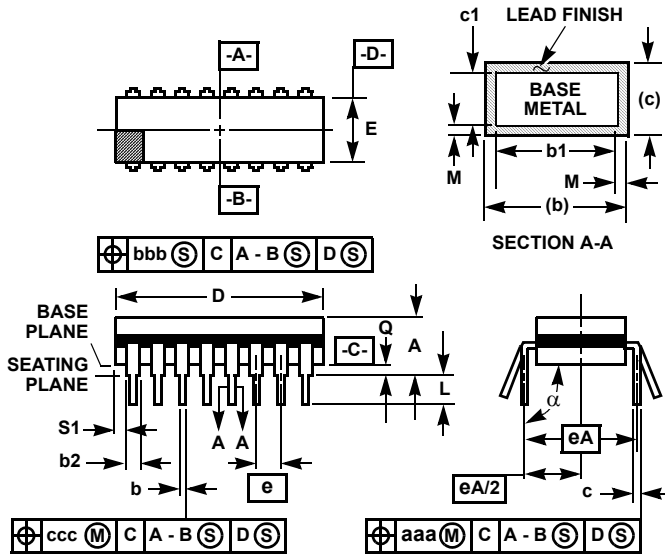

**NOTES:**

1. Index area: A notch or a pin one identification mark shall be located adjacent to pin one and shall be located within the shaded area shown. The manufacturer's identification shall not be used as a pin one identification mark.
2. The maximum limits of lead dimensions b and c or M shall be measured at the centroid of the finished lead surfaces, when solder dip or tin plate lead finish is applied.
3. Dimensions b1 and c1 apply to lead base metal only. Dimension M applies to lead plating and finish thickness.
4. Corner leads (1, N, N/2, and N/2+1) may be configured with a partial lead paddle. For this configuration dimension b3 replaces dimension b2.
5. This dimension allows for off-center lid, meniscus, and glass overrun.
6. Dimension Q shall be measured from the seating plane to the base plane.
7. Measure dimension S1 at all four corners.
8. N is the maximum number of terminal positions.
9. Dimensioning and tolerancing per ANSI Y14.5M - 1982.
10. Controlling dimension: INCH

**F8.3A MIL-STD-1835 GDIP1-T8 (D-4, CONFIGURATION A)  
8 LEAD CERAMIC DUAL-IN-LINE FRIT SEAL PACKAGE**

SYMBOL	INCHES		MILLIMETERS		NOTES
	MIN	MAX	MIN	MAX	
A	-	0.200	-	5.08	-
b	0.014	0.026	0.36	0.66	2
b1	0.014	0.023	0.36	0.58	3
b2	0.045	0.065	1.14	1.65	-
b3	0.023	0.045	0.58	1.14	4
c	0.008	0.018	0.20	0.46	2
c1	0.008	0.015	0.20	0.38	3
D	-	0.405	-	10.29	5
E	0.220	0.310	5.59	7.87	5
e	0.100 BSC		2.54 BSC		-
eA	0.300 BSC		7.62 BSC		-
eA/2	0.150 BSC		3.81 BSC		-
L	0.125	0.200	3.18	5.08	-
Q	0.015	0.060	0.38	1.52	6
S1	0.005	-	0.13	-	7
alpha	90°	105°	90°	105°	-
aaa	-	0.015	-	0.38	-
bbb	-	0.030	-	0.76	-
ccc	-	0.010	-	0.25	-
M	-	0.0015	-	0.038	2, 3
N	8		8		8

Rev. 0 4/94

© Copyright Intersil Americas LLC 2001-2015. All Rights Reserved.  
All trademarks and registered trademarks are the property of their respective owners.

For additional products, see [www.intersil.com/en/products.html](http://www.intersil.com/en/products.html)

Intersil products are manufactured, assembled and tested utilizing ISO9001 quality systems as noted in the quality certifications found at [www.intersil.com/en/support/qualandreliability.html](http://www.intersil.com/en/support/qualandreliability.html)

*Intersil products are sold by description only. Intersil may modify the circuit design and/or specifications of products at any time without notice, provided that such modification does not, in Intersil's sole judgment, affect the form, fit or function of the product. Accordingly, the reader is cautioned to verify that datasheets are current before placing orders. Information furnished by Intersil is believed to be accurate and reliable. However, no responsibility is assumed by Intersil or its subsidiaries for its use; nor for any infringements of patents or other rights of third parties which may result from its use. No license is granted by implication or otherwise under any patent or patent rights of Intersil or its subsidiaries.*

For information regarding Intersil Corporation and its products, see [www.intersil.com](http://www.intersil.com)